

297-8321-815

DMS-100 Family

Extended Peripheral Module

Extended Peripheral Module Translations Reference Manual

Volume 3 of 3

XPM14 and up Standard 14.01 March 2001

DMS-100 Family

Extended Peripheral Module

Extended Peripheral Module Translations Reference Manual

Volume 3 of 3

Publication number: 297-8321-815

Product release: XPM14 and up

Document release: Standard 14.01

Date: March 2001

Copyright © 1994-2001 Nortel Networks,
All Rights Reserved

Printed in the United States of America

NORTEL NETWORKS CONFIDENTIAL: The information contained herein is the property of Nortel Networks and is strictly confidential. Except as expressly authorized in writing by Nortel Networks, the holder shall keep all information contained herein confidential, shall disclose the information only to its employees with a need to know, and shall protect the information, in whole or in part, from disclosure and dissemination to third parties with the same degree of care it uses to protect its own confidential information, but with no less than reasonable care. Except as expressly authorized in writing by Nortel Networks, the holder is granted no rights to use the information contained herein.

Information is subject to change without notice. Nortel Networks reserves the right to make changes in design or components as progress in engineering and manufacturing may warrant. Changes or modification to the DMS-100 without the express consent of Nortel Networks may void its warranty and void the users authority to operate the equipment.

Nortel Networks, the Nortel Networks logo, the Globemark, How the World Shares Ideas, Unified Networks, DMS, DMS-100, Helmsman, MAP, Meridian, Nortel, Northern Telecom, NT, SuperNode, and TOPS are trademarks of Nortel Networks.

Contents

Extended Peripheral Module Translations Reference Manual Volume 3 of 3

NTP Summary Contents	ix
1 XPM translations introduction	1-1
2 Introduction to data tables	2-1
Tuple properties	2-1
Using the table editor	2-2
Procedures for datafilling any system	2-3
Input prompts and prompting mode	2-3
Nonprompting mode	2-4
Activating changes to tables	2-4
Table editor commands	2-4
TR-303 Generic Interface	2-7
3 Expanded Subscriber Carrier Module-100 Access (ESMA)	3-1
Understanding SMA2 translations	3-1
Introduction	3-1
The SMA2	3-1
SMA system overview	3-3
SMA system functionality	3-5
Introduction	3-5
Voice and data communications	3-5
DS-1 frame format	3-5
Superframe format signaling	3-6
Extended superframe format signaling	3-8
FXS signaling for ICB	3-10
FXS signaling	3-10
Call setup, call take-down, and call monitoring	3-13
TR-303 hybrid signaling	3-14
Robbed bit signaling	3-14
Time-slot management channel signaling	3-16
Common signaling channel signaling	3-17

- Operation, administration, maintenance, and provisioning (OAM&P) 3-18
 - EOC message signaling 3-18
- ISDN BRI signaling 3-19
 - National ISDN-2/3 BRI Phase I feature 3-20
- Bellcore compliant ADSI tones and compatible voiceband data 3-21
 - ADSI interactions 3-22
 - ADSI restriction 3-22
 - ADSI hardware requirements 3-22
- Path protection switching 3-22
 - SMA2 to generic RDT path protection switching 3-23
 - SMA2 to S/DMS AccessNode path protection switching 3-23
 - Manual path protection switching control 3-24
 - Automatic path protection switching 3-24
 - Manual and automatic protection switching restrictions 3-25
- Communication protocols 3-25
 - Q.921 CCITT LAPD protocol 3-25
 - Q.931 CCITT protocol 3-26
 - Q.931 protocol message structure 3-28
 - Protocol discriminator 3-28
 - Call reference 3-29
 - Message type 3-29
 - Information element 3-30
 - Q.931 message descriptions 3-34
 - EOC communication protocol 3-36
 - EOC protocol stack 3-38
 - Applications router 3-39
 - Operation entities 3-39
 - DS30 protocol 3-39
 - ADSI protocol 3-42
 - Physical layer 3-43
 - Data link layer 3-43
 - Message layer 3-43
- Call processing 3-43
 - Call processing (RDT to IDT) 3-43
 - Time slot request 3-43
 - Channel selection 3-44
 - Sending addressing information 3-44
 - Tone generation 3-44
 - Call disconnection 3-45
 - Flash detection 3-45
 - Busy service of subscriber lines 3-46
 - Call processing (IDT to RDT) 3-46
 - Time slot request 3-46
 - Network busy call treatment 3-46
 - Channel selection 3-47
 - Alerting 3-47
 - On-hook transmission 3-48
 - Custom local area signaling service (CLASS) calling number delivery (CND) 3-48
 - Loss padding 3-48
 - Call disconnection 3-48

Flash detection	3-49
Busy service of subscriber lines	3-49
Call processing coin operation	3-49
Coin collect	3-50
Coin return	3-50
Coin presence	3-50
Coin partial presence	3-50
Battery commands	3-50
Reverse battery	3-50
Normal battery	3-51
Subscriber line signaling	3-51
Coin operation limits and interactions	3-51
SMA2 service capabilities	3-51
Plain ordinary telephone service (POTS)	3-51
Coin operation service	3-52
Coin first	3-52
Coin dial-tone first	3-53
Coin semi-postpay	3-53
Coin call functionality	3-54
Message waiting indicator	3-54
Message waiting lamp	3-54
Meridian business set messaging	3-54
MBS on AccessNode	3-55
MBS on MVI RDT	3-55
Universal tone receiver services	3-55
Direct Outward Dial (DOD)	3-56
Custom local area signaling service	3-56
Meridian Digital Centrex (MDC) features on 500/2500 sets and attendant consoles	3-56
Off-premise extension (bridged service)	3-57
Private branch exchange (PBX) central office access	3-58
Residential services	3-58
Secretarial line	3-58
Teen service	3-58
Toll diversion	3-58
Wide area telecommunications services	3-58
800 service	3-58
ISDN services	3-59
Ringling	3-59
Dialing	3-60
Tones	3-60
Deluxe Spontaneous Call Waiting Identification	3-60
Preparing to datafill SMA2	3-66
PCL—New software delivery vehicle	3-66
Tasks associated with datafilling SMA2	3-66
Static datalog tracking	3-67
DMS recognition of the switching unit and all remote locations	3-68
SCM-100 Software for AccessNode	3-70
SMA ICB Links	3-211

4	Remote Switching Center-SONET	4-1
	Understanding RSC-S translations	4-1
	RSC-S development	4-1
	RSC-S development schedule	4-2
	Differences between RSC and RSC-S	4-2
	Software functionality	4-2
	Revised system architecture	4-3
	Packaging	4-3
	Cabinetized remote switching center cabinet	4-4
	CRSC extension unit	4-5
	Cabinetized line modules	4-6
	Cabinetized power distribution center cabinet	4-7
	Cabinetized miscellaneous equipment cabinet	4-7
	Cabinetized miscellaneous spares storage cabinet	4-7
	RSC-S services	4-7
	RSC-S configurations	4-8
	DS-1 electrical interface	4-13
	Signaling for RSC-S	4-14
	Signal additions	4-14
	DDL signaling to SLC-96	4-14
	Incoming DDL	4-14
	Outgoing DDL	4-14
	DDL for extended superframe	4-14
	DDL processing	4-15
	Extended frame format	4-15
	SONET format	4-16
	Preparing to datafill RSC-S	4-16
	PCL—New Software Delivery Vehicle	4-16
	Collecting end-user data	4-17
	Configurations	4-17
	Overview of datafill requirements	4-18
	Activating the RSC-S	4-18
	Datafilling dynamic trunks	4-18
	When to update the RCC2 static data	4-18
	Alarms produced when a static data mismatch occurs	4-19
	TUPC logs for static data updates	4-19
	Types of TUPC logs	4-19
	TUPC log format	4-20
	SERVORD option NPGD for line cards NT6X18AA and NT6X18AB	4-20
	Basic call processing	4-22
	Custom Local Area Signaling Services	4-108
	Trunks	4-135
	ESA Lines	4-149
	ESA Lines and Trunks	4-166
	Dual Remote Cluster Controller 2	4-185
	ISDN operations	4-201
	Downloading firmware	4-271
	Subscriber Module SLC-96/Remote	4-288
	Enhanced ESA (Lines and Trunks)	4-311

Enhanced ESA for ISDN (Lines Only)	4-328
Enhanced ESA for ISDN (Lines and Trunks)	4-339
HSTP0 DMS ADSL Capability	4-355

5	Subscriber Carrier Module-100S Remote	5-1
	Understanding SMS-R translations	5-1
	Signaling for SMS-R	5-1
	SMS-R/RCS signaling links	5-1
	Signaling protocols	5-3
	SMS-R/RCS signaling functions	5-7
	Preparing to datafill SMS-R	5-17
	PCL—New software delivery vehicle	5-17
	Tasks associated with datafilling the SMS-R/RCS system	5-17
	Protection lines	5-18
	Special services nailed-up cross-connections	5-18
	Controlling RCS modes	5-18
	Static datalog tracking	5-18
	Basic Call Processing	5-21
	Special Services	5-98
	Custom Local Area Signaling Services	5-107
	Meridian Digital Centrex Basic	5-117

NTP Summary Contents

Extended Peripheral Module Translations Reference Manual Volume 1 of 3

About this document		Vol. 1, xxi
	How to check the version and issue of this document	Vol. 1, xxi
	References in this document	Vol. 1, xxi
	What precautionary messages mean	Vol. 1, xxii
	How commands, parameters, and responses are represented	Vol. 1, xxiii
	Input prompt (>)	Vol. 1, xxiii
	Commands and fixed parameters	Vol. 1, xxiii
	Variables	Vol. 1, xxiii
	Responses	Vol. 1, xxiv
<hr/>		
1	XPM translations introduction	Vol. 1, 1-1
<hr/>		
2	Introduction to data tables	Vol. 1, 2-1
	Tuple properties	Vol. 1, 2-1
	Using the table editor	Vol. 1, 2-2
	Procedures for datafilling any system	Vol. 1, 2-3
	Input prompts and prompting mode	Vol. 1, 2-3
	Nonprompting mode	Vol. 1, 2-4
	Activating changes to tables	Vol. 1, 2-4
	Table editor commands	Vol. 1, 2-4
<hr/>		
3	Outside Plant Module	Vol. 1, 3-1
	Understanding OPM translations	Vol. 1, 3-1
	Introduction to the OPM	Vol. 1, 3-1
	Signaling for the OPM	Vol. 1, 3-2
	The OPM signaling links	Vol. 1, 3-2
	Message channels	Vol. 1, 3-3
	Signaling protocol	Vol. 1, 3-3
	The DMS-X protocol	Vol. 1, 3-3
	Signaling functions	Vol. 1, 3-5
	Call origination	Vol. 1, 3-6
	Tone generation	Vol. 1, 3-6
	Digit collection	Vol. 1, 3-6
	Dial pulse signaling	Vol. 1, 3-7
	DTMF signaling	Vol. 1, 3-7

- End-to-end signaling Vol. 1, 3-7
- Ringing Vol. 1, 3-7
- ESA signaling Vol. 1, 3-8
- Preparing to datafill OPM Vol. 1, 3-8
 - PCL—New Software Delivery Vehicle Vol. 1, 3-8
 - Tasks associated with datafilling the OPM Vol. 1, 3-9
 - Procedures for datafilling procedures for the OPM Vol. 1, 3-9
- Basic call processing Vol. 1, 3-11
- OPM maintenance Vol. 1, 3-95
- RLCM Intracalling Vol. 1, 3-106
- RLCM ESA Operation Vol. 1, 3-112

4 Remote Line Concentrating Module Vol. 1, 4-1

- Understanding RLCM translations Vol. 1, 4-1
 - Introduction to the RLCM Vol. 1, 4-1
- Signaling for RLCM Vol. 1, 4-2
 - RLCM signaling links Vol. 1, 4-2
 - Message channels Vol. 1, 4-3
 - Signaling protocol Vol. 1, 4-3
 - DMS-X protocol Vol. 1, 4-3
 - Signaling functions Vol. 1, 4-5
 - Call origination Vol. 1, 4-6
 - Tone generation Vol. 1, 4-6
 - Digit collection Vol. 1, 4-6
 - Dial pulse signaling Vol. 1, 4-7
 - DTMF signaling Vol. 1, 4-7
 - End-to-end signaling Vol. 1, 4-7
 - Ringing Vol. 1, 4-7
 - ESA signaling Vol. 1, 4-8
- Preparing to datafill RLCM Vol. 1, 4-8
 - PCL—New Software Delivery Vehicle Vol. 1, 4-8
 - Tasks associated with datafilling the RLCM Vol. 1, 4-9
 - Procedures for datafilling the RLCM Vol. 1, 4-9
- Basic call processing Vol. 1, 4-11
- ESA Operation RLCM Vol. 1, 4-94
- HSTP0 DMS ADSL Capability Vol. 1, 4-119
- RLCM Intracalling Vol. 1, 4-131

5 Outside Plant Access Cabinet Vol. 1, 5-1

- Understanding OPAC translations Vol. 1, 5-1
 - Introduction to OPAC translations Vol. 1, 5-1
- Signaling for OPAC Vol. 1, 5-2
 - OPAC signaling links Vol. 1, 5-3
 - Message channels Vol. 1, 5-3
 - Signaling protocol Vol. 1, 5-4
 - The DMS-X protocol Vol. 1, 5-4
 - Signaling functions Vol. 1, 5-6
 - Call origination Vol. 1, 5-6
 - Tone generation Vol. 1, 5-6
 - Digit collection Vol. 1, 5-6

Dial pulsing Vol. 1, 5-7
 The DTMF signaling Vol. 1, 5-7
 End-to-end Vol. 1, 5-7
 Ringing Vol. 1, 5-7
 The ESA signaling feature Vol. 1, 5-8
 How to enter data in the OPAC Vol. 1, 5-8
 The PCL—New Software Delivery Vehicle Vol. 1, 5-8
 Tasks associated with entering data in the OPAC Vol. 1, 5-9
 Procedures for datafilling the OPAC Vol. 1, 5-9
 Basic call processing Vol. 1, 5-10
 ESA Operation RLCM Vol. 1, 5-124
 OPM Maintenance Vol. 1, 5-150
 RLCM Intracalling Vol. 1, 5-161

6 Remote Switching Center Vol. 1, 6-1

Understanding RSC translations Vol. 1, 6-1
 RSC development Vol. 1, 6-1
 RSC services Vol. 1, 6-4
 RSC configurations Vol. 1, 6-4
 DS-1 electrical interface Vol. 1, 6-9
 Preparing to datafill RSC Vol. 1, 6-9
 PCL—New Software Delivery Vehicle Vol. 1, 6-9
 Overview of datafill requirements Vol. 1, 6-10
 Basic call processing Vol. 1, 6-14
 Custom Local Area Signaling Service Vol. 1, 6-113
 Dual Remote Cluster Controller Vol. 1, 6-140
 Enhanced ESA (Lines and Trunks) Vol. 1, 6-164
 ESA lines Vol. 1, 6-175
 ESA (Lines and Trunks) Vol. 1, 6-193
 HSTP0 DMS ADSL Capability Vol. 1, 6-224
 New Peripheral Maintenance Vol. 1, 6-236
 Trunking Vol. 1, 6-246
 Firmware Downloading Vol. 1, 6-267
 XPM-PLUS Vol. 1, 6-278

Extended Peripheral Module Translations Reference Manual Volume 2 of 3

1 XPM translations introduction Vol. 2, 1-1

2 Introduction to data tables Vol. 2, 2-1

Tuple properties Vol. 2, 2-1
 Using the table editor Vol. 2, 2-2
 Procedures for datafilling any system Vol. 2, 2-3
 Input prompts and prompting mode Vol. 2, 2-3
 Nonprompting mode Vol. 2, 2-4
 Activating changes to tables Vol. 2, 2-4
 Table editor commands Vol. 2, 2-4

3 Subscriber Carrier Module-100S **Vol. 2, 3-1**

- Understanding SMS translations Vol. 2, 3-1
- Signaling for SMS Vol. 2, 3-1
 - SMS-RCS signaling links Vol. 2, 3-1
 - Signaling protocols Vol. 2, 3-3
 - SMS-RCS signaling functions Vol. 2, 3-6
- Preparing to datafill SMS Vol. 2, 3-16
 - PCL—New software delivery vehicle Vol. 2, 3-16
 - Tasks associated with the SMS-RCS system Vol. 2, 3-17
 - Protection lines Vol. 2, 3-17
 - Special services nailed-up cross connections Vol. 2, 3-17
 - Controlling RCS modes Vol. 2, 3-17
 - Static datalog tracking Vol. 2, 3-18
- Basic call processing Vol. 2, 3-19
- Custom Local Area Signaling Services Vol. 2, 3-121
- Meridian Digital Centrex Basic Vol. 2, 3-148
- Special Services Vol. 2, 3-150

4 Subscriber Carrier Module Urban **Vol. 2, 4-1**

- SMU translations Vol. 2, 4-1
 - Introduction to subscriber carrier systems Vol. 2, 4-1
 - Subscriber carrier systems in the DMS-100 family Vol. 2, 4-1
 - The Subscriber Carrier Module-100 Urban Vol. 2, 4-3
- Signaling for SMU Vol. 2, 4-4
 - SMU signaling links Vol. 2, 4-4
 - A-and B-bit signaling Vol. 2, 4-6
 - Per-channel signaling Vol. 2, 4-6
 - Coin signaling Vol. 2, 4-6
 - FXB special service signaling Vol. 2, 4-6
 - Message channels Vol. 2, 4-6
 - ISDN BRI signaling Vol. 2, 4-7
 - National ISDN-2/3 BRI Phase I Vol. 2, 4-8
 - MBS signaling Vol. 2, 4-9
 - Signaling protocols Vol. 2, 4-10
 - A-and B-bit messages Vol. 2, 4-10
 - DMS-X protocol Vol. 2, 4-10
 - Q.931 Digital Network Access protocol Vol. 2, 4-13
 - SMU signaling functions Vol. 2, 4-13
 - Peripheral processor (PP) SMU basic all processing Vol. 2, 4-14
 - Origination and channel allocation Vol. 2, 4-14
 - Tone generation Vol. 2, 4-15
 - Digit collection Vol. 2, 4-16
 - Ringling Vol. 2, 4-16
 - Automatic number identification Vol. 2, 4-17
 - Loss padding Vol. 2, 4-17
 - Messaging loss Vol. 2, 4-17
 - Busy/return to service of subscriber lines Vol. 2, 4-18
 - Limits to call processing Vol. 2, 4-18
 - SMU-RCU coin operation Vol. 2, 4-18
 - Coin operation limits and interactions Vol. 2, 4-21

RCU to SMU signaling	Vol. 2, 4-21
SMU to computing module (CM) messages	Vol. 2, 4-21
Preparing to datafill SMU	Vol. 2, 4-22
PCL—New software delivery vehicle	Vol. 2, 4-22
SMU static data update	Vol. 2, 4-22
Static datalog tracking	Vol. 2, 4-23
Basic Call Processing	Vol. 2, 4-24
Custom Local Area Signaling Services	Vol. 2, 4-120
Special Services	Vol. 2, 4-142

5	Subscriber Carrier Module-100 Access	Vol. 2, 5-1
	Understanding SMA translations	Vol. 2, 5-1
	The Subscriber Carrier Module-100 Access	Vol. 2, 5-1
	SMA system summary	Vol. 2, 5-1
	SMA system functionality	Vol. 2, 5-3
	Introduction	Vol. 2, 5-3
	Voice and data communications	Vol. 2, 5-3
	DS-1 frame format	Vol. 2, 5-3
	Extended superframe format signaling	Vol. 2, 5-4
	Call setup, call take-down, and call monitoring	Vol. 2, 5-6
	Common signaling channel signaling	Vol. 2, 5-6
	Operation, administration, maintenance, and provisioning (OAM&P)	Vol. 2, 5-7
	EOC message signaling	Vol. 2, 5-7
	ISDN BRI signaling	Vol. 2, 5-9
	National ISDN-2/3 BRI Phase I feature	Vol. 2, 5-9
	Bellcore compliant ADSI tones and compatible voiceband data	Vol. 2, 5-10
	ADSI interactions	Vol. 2, 5-11
	ADSI limit	Vol. 2, 5-11
	ADSI hardware requirements	Vol. 2, 5-11
	Path protection switching	Vol. 2, 5-12
	SMA to S/DMS AccessNode path protection switching	Vol. 2, 5-12
	Manual path protection switching control	Vol. 2, 5-13
	Automatic path protection switching	Vol. 2, 5-13
	Manual and automatic protection switching limits	Vol. 2, 5-14
	Communication protocols	Vol. 2, 5-14
	Q.921 CCITT LAPD protocol	Vol. 2, 5-14
	Q.931 CCITT protocol	Vol. 2, 5-15
	Q.931 protocol message structure	Vol. 2, 5-16
	Protocol discriminator	Vol. 2, 5-17
	Call reference	Vol. 2, 5-17
	Message type	Vol. 2, 5-18
	Information element	Vol. 2, 5-19
	Q.931 message descriptions	Vol. 2, 5-22
	EOC communication protocol	Vol. 2, 5-24
	EOC protocol stack	Vol. 2, 5-26
	Applications router	Vol. 2, 5-27
	Operation entities	Vol. 2, 5-27
	DS30 protocol	Vol. 2, 5-28
	ADSI protocol	Vol. 2, 5-30

Physical layer	Vol. 2, 5-31
Data link layer	Vol. 2, 5-31
Message layer	Vol. 2, 5-31
Call processing	Vol. 2, 5-31
Call processing (RDT to IDT)	Vol. 2, 5-31
Time slot request	Vol. 2, 5-31
Channel selection	Vol. 2, 5-32
Sending addressing information	Vol. 2, 5-32
Tone generation	Vol. 2, 5-32
Call disconnection	Vol. 2, 5-33
Flash detection	Vol. 2, 5-34
Busy service of subscriber lines	Vol. 2, 5-34
Call processing (IDT to RDT)	Vol. 2, 5-34
Time slot request	Vol. 2, 5-34
Network busy call treatment	Vol. 2, 5-35
Channel selection	Vol. 2, 5-35
Alerting	Vol. 2, 5-35
On-hook transmission	Vol. 2, 5-36
Custom local area signaling service (CLASS) calling number delivery (CND)	Vol. 2, 5-36
Loss padding	Vol. 2, 5-36
Call disconnection	Vol. 2, 5-37
Flash detection	Vol. 2, 5-37
Busy service of subscriber lines	Vol. 2, 5-38
Call processing coin operation	Vol. 2, 5-38
Coin commands	Vol. 2, 5-38
Coin collect	Vol. 2, 5-38
Coin return	Vol. 2, 5-38
Coin presence	Vol. 2, 5-38
Coin partial presence	Vol. 2, 5-39
Battery commands	Vol. 2, 5-39
Reverse battery	Vol. 2, 5-39
Normal battery	Vol. 2, 5-39
Subscriber line signaling	Vol. 2, 5-39
Coin operations limits and interactions	Vol. 2, 5-39
SMA service capabilities	Vol. 2, 5-40
Plain ordinary telephone service (POTS)	Vol. 2, 5-40
Coin operation service	Vol. 2, 5-40
Coin first	Vol. 2, 5-40
Coin dial-tone first	Vol. 2, 5-41
Coin semi-postpay	Vol. 2, 5-42
Coin call functionality	Vol. 2, 5-42
Custom calling features for Meridian business sets (MBS)	Vol. 2, 5-43
Message waiting indicator	Vol. 2, 5-44
Message waiting lamp	Vol. 2, 5-44
Meridian business set messaging	Vol. 2, 5-44
Universal tone receiver services	Vol. 2, 5-45
Direct Outward Dial (DOD)	Vol. 2, 5-45
Custom local area signaling service	Vol. 2, 5-45
Meridian Digital Centrex (MDC) features on 500/2500 sets and attendant consoles	Vol. 2, 5-45

Multiple appearance directory number (MADN) feature	Vol. 2, 5-46
MADN members provisioning	Vol. 2, 5-46
Off-premise extension (bridged service)	Vol. 2, 5-47
Private branch exchange (PBX) central office access	Vol. 2, 5-47
Residential services	Vol. 2, 5-47
Secretarial line	Vol. 2, 5-47
Teen service	Vol. 2, 5-47
Toll diversion	Vol. 2, 5-48
Wide area telecommunications services	Vol. 2, 5-48
800 service	Vol. 2, 5-48
ISDN services	Vol. 2, 5-48
Ringling	Vol. 2, 5-49
Dialing	Vol. 2, 5-49
Tones	Vol. 2, 5-49
SMA line card support	Vol. 2, 5-49
Deluxe Spontaneous Call Waiting Identification	Vol. 2, 5-50
Preparing to datafill SMA	Vol. 2, 5-56
PCL—New software delivery vehicle	Vol. 2, 5-56
Tasks associated with datafilling the SMA	Vol. 2, 5-56
Static datalog tracking	Vol. 2, 5-56
When to update static data	Vol. 2, 5-57
Dynamic static date update	Vol. 2, 5-58
DMS recognition of the switching unit and all remote locations	Vol. 2, 5-58
Base SCM Access	Vol. 2, 5-60

6 Subscriber Carrier Module-100 Access MVI-20 Vol. 2, 6-1

Understanding SMA translations	Vol. 2, 6-1
The Subscriber Carrier Module-100 Access	Vol. 2, 6-1
SMA system overview	Vol. 2, 6-1
SMA system functionality	Vol. 2, 6-3
Introduction	Vol. 2, 6-3
Voice and data communications	Vol. 2, 6-3
DS-1 frame format	Vol. 2, 6-3
Extended superframe format signaling	Vol. 2, 6-4
Call setup, call take-down, and call monitoring	Vol. 2, 6-6
TR-303 hybrid signaling	Vol. 2, 6-6
Operation, administration, maintenance, and provisioning (OAM&P)	Vol. 2, 6-9
EOC message signaling	Vol. 2, 6-9
ISDN BRI signaling	Vol. 2, 6-10
National ISDN-2/3 BRI Phase I feature	Vol. 2, 6-11
Bellcore compliant ADSI tones and compatible voiceband data	Vol. 2, 6-11
ADSI interactions	Vol. 2, 6-13
ADSI restriction	Vol. 2, 6-13
ADSI hardware requirements	Vol. 2, 6-13
Path protection switching	Vol. 2, 6-13
SMA to generic RDT path protection switching	Vol. 2, 6-14
Manual path protection switching control	Vol. 2, 6-15
Automatic path protection switching	Vol. 2, 6-15

- Manual and automatic protection switching restrictions Vol. 2, 6-16
- Communication protocols Vol. 2, 6-16
 - Q.921 CCITT LAPD protocol Vol. 2, 6-16
 - Q.931 CCITT protocol Vol. 2, 6-17
 - EOC communication protocol Vol. 2, 6-23
 - DS30 protocol Vol. 2, 6-26
 - ADSI protocol Vol. 2, 6-29
- Call processing Vol. 2, 6-30
 - Call processing (RDT to IDT) Vol. 2, 6-30
 - Call processing (IDT to RDT) Vol. 2, 6-33
 - Call processing coin operation Vol. 2, 6-36
- SMA service capabilities Vol. 2, 6-38
 - Plain ordinary telephone service (POTS) Vol. 2, 6-38
 - Coin operation service Vol. 2, 6-38
 - Coin call functionality Vol. 2, 6-40
 - Universal tone receiver services Vol. 2, 6-40
 - Custom local area signaling service Vol. 2, 6-40
 - Meridian Digital Centrex (MDC) features on 500/2500 sets and attendant consoles Vol. 2, 6-40
 - Off-premise extension (bridged service) Vol. 2, 6-40
 - Private branch exchange (PBX) central office access Vol. 2, 6-41
 - Residential services Vol. 2, 6-41
 - Secretarial line Vol. 2, 6-41
 - Teen service Vol. 2, 6-41
 - Toll diversion Vol. 2, 6-41
 - Wide area telecommunications services Vol. 2, 6-41
 - 800 service Vol. 2, 6-41
 - ISDN services Vol. 2, 6-41
 - Ringling Vol. 2, 6-42
 - Dialing Vol. 2, 6-43
 - Tones Vol. 2, 6-43
 - Deluxe Spontaneous Call Waiting Identification Vol. 2, 6-43
- Preparing to datafill SMA Vol. 2, 6-48
 - PCL—New software delivery vehicle Vol. 2, 6-48
 - Tasks associated with datafilling the SMA Vol. 2, 6-48
 - Static datalog tracking Vol. 2, 6-48
- TR-303 Generic Interface Vol. 2, 6-51

7	Introduction to Star Remote System	Vol. 2, 7-1
	Understanding Star Remote System translations	Vol. 2, 7-1
	Introduction to the Star Remote System	Vol. 2, 7-1
	Voice and data communications	Vol. 2, 7-5
	ISDN BRI signaling	Vol. 2, 7-9
	Communication protocol	Vol. 2, 7-10
	Signaling functions and capabilities	Vol. 2, 7-10
	Star Remote System service capabilities	Vol. 2, 7-11
	1-Meg Modem Service supported protocols	Vol. 2, 7-16
	Preparing to datafill Star Remote System	Vol. 2, 7-18
	Functional group for Star Remote System	Vol. 2, 7-18
	Tasks associated with datafilling the Star Remote System	Vol. 2, 7-18

Procedures for datafilling the Star Remote System	Vol. 2, 7-18
Functional group for 1-Meg Modem on Star Hub	Vol. 2, 7-19
Tasks associated with datafilling the 1-Meg Modem service on Star Hub	Vol. 2, 7-19
Procedures for datafilling 1-Meg Modem service on Star Hub	Vol. 2, 7-19
Basic call processing	Vol. 2, 7-20
ESA operation for the Star Remote System	Vol. 2, 7-129
HSTP0 DMS ADSL Capability	Vol. 2, 7-151

Extended Peripheral Module Translations Reference Manual Volume 3 of 3

1	XPM translations introduction	Vol. 3, 1-1
2	Introduction to data tables	Vol. 3, 2-1
	Tuple properties	Vol. 3, 2-1
	Using the table editor	Vol. 3, 2-2
	Procedures for datafilling any system	Vol. 3, 2-3
	Input prompts and prompting mode	Vol. 3, 2-3
	Nonprompting mode	Vol. 3, 2-4
	Activating changes to tables	Vol. 3, 2-4
	Table editor commands	Vol. 3, 2-4
	TR-303 Generic Interface	Vol. 3, 2-7
3	Expanded Subscriber Carrier Module-100 Access (ESMA)	Vol. 3, 3-1
	Understanding SMA2 translations	Vol. 3, 3-1
	Introduction	Vol. 3, 3-1
	The SMA2	Vol. 3, 3-1
	SMA system overview	Vol. 3, 3-3
	SMA system functionality	Vol. 3, 3-5
	Introduction	Vol. 3, 3-5
	Voice and data communications	Vol. 3, 3-5
	DS-1 frame format	Vol. 3, 3-5
	Superframe format signaling	Vol. 3, 3-6
	Extended superframe format signaling	Vol. 3, 3-8
	FXS signaling for ICB	Vol. 3, 3-10
	FXS signaling	Vol. 3, 3-10
	Call setup, call take-down, and call monitoring	Vol. 3, 3-13
	TR-303 hybrid signaling	Vol. 3, 3-14
	Robbed bit signaling	Vol. 3, 3-14
	Time-slot management channel signaling	Vol. 3, 3-16
	Common signaling channel signaling	Vol. 3, 3-17
	Operation, administration, maintenance, and provisioning (OAM&P)	Vol. 3, 3-18
	EOC message signaling	Vol. 3, 3-18

- ISDN BRI signaling Vol. 3, 3-19
 - National ISDN-2/3 BRI Phase I feature Vol. 3, 3-20
- Bellcore compliant ADSI tones and compatible voiceband data Vol. 3, 3-21
 - ADSI interactions Vol. 3, 3-22
 - ADSI restriction Vol. 3, 3-22
 - ADSI hardware requirements Vol. 3, 3-22
- Path protection switching Vol. 3, 3-22
 - SMA2 to generic RDT path protection switching Vol. 3, 3-23
 - SMA2 to S/DMS AccessNode path protection switching Vol. 3, 3-23
 - Manual path protection switching control Vol. 3, 3-24
 - Automatic path protection switching Vol. 3, 3-24
 - Manual and automatic protection switching restrictions Vol. 3, 3-25
- Communication protocols Vol. 3, 3-25
 - Q.921 CCITT LAPD protocol Vol. 3, 3-25
 - Q.931 CCITT protocol Vol. 3, 3-26
 - Q.931 protocol message structure Vol. 3, 3-28
 - Protocol discriminator Vol. 3, 3-28
 - Call reference Vol. 3, 3-29
 - Message type Vol. 3, 3-29
 - Information element Vol. 3, 3-30
 - Q.931 message descriptions Vol. 3, 3-34
 - EOC communication protocol Vol. 3, 3-36
 - EOC protocol stack Vol. 3, 3-38
 - Applications router Vol. 3, 3-39
 - Operation entities Vol. 3, 3-39
 - DS30 protocol Vol. 3, 3-39
 - ADSI protocol Vol. 3, 3-42
 - Physical layer Vol. 3, 3-43
 - Data link layer Vol. 3, 3-43
 - Message layer Vol. 3, 3-43
- Call processing Vol. 3, 3-43
 - Call processing (RDT to IDT) Vol. 3, 3-43
 - Time slot request Vol. 3, 3-43
 - Channel selection Vol. 3, 3-44
 - Sending addressing information Vol. 3, 3-44
 - Tone generation Vol. 3, 3-44
 - Call disconnection Vol. 3, 3-45
 - Flash detection Vol. 3, 3-45
 - Busy service of subscriber lines Vol. 3, 3-46
 - Call processing (IDT to RDT) Vol. 3, 3-46
 - Time slot request Vol. 3, 3-46
 - Network busy call treatment Vol. 3, 3-46
 - Channel selection Vol. 3, 3-47
 - Alerting Vol. 3, 3-47
 - On-hook transmission Vol. 3, 3-48
 - Custom local area signaling service (CLASS) calling number delivery (CND) Vol. 3, 3-48
 - Loss padding Vol. 3, 3-48
 - Call disconnection Vol. 3, 3-48
 - Flash detection Vol. 3, 3-49
 - Busy service of subscriber lines Vol. 3, 3-49

Call processing coin operation	Vol. 3, 3-49
Coin collect	Vol. 3, 3-50
Coin return	Vol. 3, 3-50
Coin presence	Vol. 3, 3-50
Coin partial presence	Vol. 3, 3-50
Battery commands	Vol. 3, 3-50
Reverse battery	Vol. 3, 3-50
Normal battery	Vol. 3, 3-51
Subscriber line signaling	Vol. 3, 3-51
Coin operation limits and interactions	Vol. 3, 3-51
SMA2 service capabilities	Vol. 3, 3-51
Plain ordinary telephone service (POTS)	Vol. 3, 3-51
Coin operation service	Vol. 3, 3-52
Coin first	Vol. 3, 3-52
Coin dial-tone first	Vol. 3, 3-53
Coin semi-postpay	Vol. 3, 3-53
Coin call functionality	Vol. 3, 3-54
Message waiting indicator	Vol. 3, 3-54
Message waiting lamp	Vol. 3, 3-54
Meridian business set messaging	Vol. 3, 3-54
MBS on AccessNode	Vol. 3, 3-55
MBS on MVI RDT	Vol. 3, 3-55
Universal tone receiver services	Vol. 3, 3-55
Direct Outward Dial (DOD)	Vol. 3, 3-56
Custom local area signaling service	Vol. 3, 3-56
Meridian Digital Centrex (MDC) features on 500/2500 sets and attendant consoles	Vol. 3, 3-56
Off-premise extension (bridged service)	Vol. 3, 3-57
Private branch exchange (PBX) central office access	Vol. 3, 3-58
Residential services	Vol. 3, 3-58
Secretarial line	Vol. 3, 3-58
Teen service	Vol. 3, 3-58
Toll diversion	Vol. 3, 3-58
Wide area telecommunications services	Vol. 3, 3-58
800 service	Vol. 3, 3-58
ISDN services	Vol. 3, 3-59
Ringling	Vol. 3, 3-59
Dialing	Vol. 3, 3-60
Tones	Vol. 3, 3-60
Deluxe Spontaneous Call Waiting Identification	Vol. 3, 3-60
Preparing to datafill SMA2	Vol. 3, 3-66
PCL—New software delivery vehicle	Vol. 3, 3-66
Tasks associated with datafilling SMA2	Vol. 3, 3-66
Static datalog tracking	Vol. 3, 3-67
DMS recognition of the switching unit and all remote locations	Vol. 3, 3-68
SCM-100 Software for AccessNode	Vol. 3, 3-70
SMA ICB Links	Vol. 3, 3-211

4	Remote Switching Center-SONET	Vol. 3, 4-1
	Understanding RSC-S translations	Vol. 3, 4-1
	RSC-S development	Vol. 3, 4-1
	RSC-S development schedule	Vol. 3, 4-2
	Differences between RSC and RSC-S	Vol. 3, 4-2
	Software functionality	Vol. 3, 4-2
	Revised system architecture	Vol. 3, 4-3
	Packaging	Vol. 3, 4-3
	Cabinetized remote switching center cabinet	Vol. 3, 4-4
	CRSC extension unit	Vol. 3, 4-5
	Cabinetized line modules	Vol. 3, 4-6
	Cabinetized power distribution center cabinet	Vol. 3, 4-7
	Cabinetized miscellaneous equipment cabinet	Vol. 3, 4-7
	Cabinetized miscellaneous spares storage cabinet	Vol. 3, 4-7
	RSC-S services	Vol. 3, 4-7
	RSC-S configurations	Vol. 3, 4-8
	DS-1 electrical interface	Vol. 3, 4-13
	Signaling for RSC-S	Vol. 3, 4-14
	Signal additions	Vol. 3, 4-14
	DDL signaling to SLC-96	Vol. 3, 4-14
	Incoming DDL	Vol. 3, 4-14
	Outgoing DDL	Vol. 3, 4-14
	DDL for extended superframe	Vol. 3, 4-14
	DDL processing	Vol. 3, 4-15
	Extended frame format	Vol. 3, 4-15
	SONET format	Vol. 3, 4-16
	Preparing to datafill RSC-S	Vol. 3, 4-16
	PCL—New Software Delivery Vehicle	Vol. 3, 4-16
	Collecting end-user data	Vol. 3, 4-17
	Configurations	Vol. 3, 4-17
	Overview of datafill requirements	Vol. 3, 4-18
	Activating the RSC-S	Vol. 3, 4-18
	Datafilling dynamic trunks	Vol. 3, 4-18
	When to update the RCC2 static data	Vol. 3, 4-18
	Alarms produced when a static data mismatch occurs	Vol. 3, 4-19
	TUPC logs for static data updates	Vol. 3, 4-19
	Types of TUPC logs	Vol. 3, 4-19
	TUPC log format	Vol. 3, 4-20
	SERVORD option NPGD for line cards NT6X18AA and NT6X18AB	Vol. 3, 4-20
	Basic call processing	Vol. 3, 4-22
	Custom Local Area Signaling Services	Vol. 3, 4-108
	Trunks	Vol. 3, 4-135
	ESA Lines	Vol. 3, 4-149
	ESA Lines and Trunks	Vol. 3, 4-166
	Dual Remote Cluster Controller 2	Vol. 3, 4-185
	ISDN operations	Vol. 3, 4-201
	Downloading firmware	Vol. 3, 4-271
	Subscriber Module SLC-96/Remote	Vol. 3, 4-288
	Enhanced ESA (Lines and Trunks)	Vol. 3, 4-311

Enhanced ESA for ISDN (Lines Only) Vol. 3, 4-328
Enhanced ESA for ISDN (Lines and Trunks) Vol. 3, 4-339
HSTP0 DMS ADSL Capability Vol. 3, 4-355

5	Subscriber Carrier Module-100S Remote	Vol. 3, 5-1
	Understanding SMS-R translations	Vol. 3, 5-1
	Signaling for SMS-R	Vol. 3, 5-1
	SMS-R/RCS signaling links	Vol. 3, 5-1
	Signaling protocols	Vol. 3, 5-3
	SMS-R/RCS signaling functions	Vol. 3, 5-7
	Preparing to datafill SMS-R	Vol. 3, 5-17
	PCL—New software delivery vehicle	Vol. 3, 5-17
	Tasks associated with datafilling the SMS-R/RCS system	Vol. 3, 5-17
	Protection lines	Vol. 3, 5-18
	Special services nailed-up cross-connections	Vol. 3, 5-18
	Controlling RCS modes	Vol. 3, 5-18
	Static datalog tracking	Vol. 3, 5-18
	Basic Call Processing	Vol. 3, 5-21
	Special Services	Vol. 3, 5-98
	Custom Local Area Signaling Services	Vol. 3, 5-107
	Meridian Digital Centrex Basic	Vol. 3, 5-117

1 XPM translations introduction

This extended peripheral module (XPM) translations reference manual provides a product overview; translations datafill procedures; description of basic and optional XPM feature capabilities; and describes how specific tables activate, deactivate, or alter product capabilities for the following XPMs:

- Outside Plant Access Cabinet (OPAC)
- Remote Line Concentrating Module (RLCM)/Outside Plant Module (OPM)
- Remote Switching Center (RSC)
- Remote Switching Center-SONET (Synchronous Optical Network) (RSC-S)
- Subscriber Carrier Module-100 Access (SMA)
- Subscriber Carrier Module-100S (SMS)
- Subscriber Carrier Module-100S Remote (SMS-R)
- Subscriber Carrier Module-100 Urban (SMU)

2 Introduction to data tables

The translations database contains numerous data tables. Each table has a specific purpose and contains a certain type of data. Datafilling is the term used to describe the process of entering the specific data into a table. The following section describes the composition of data tables.

Data associated with hardware and software systems of the Digital Multiplex System (DMS) switch are stored in the form of two-dimensional entities called tables.

A table consists of rows and columns. A row is called a *tuple*. Columns represent *fields* in a tuple. Refer to the following figure for examples of a table, subtable, and sub-subtable.

Each field has a unique field name consisting of a maximum of eight characters. The field name is used as a prompt for data input.

A field is either a single-element field or a multiple-element field with subfields. A field or subfield contains data expressed in the form of numbers or alphanumeric strings.

Tuple properties

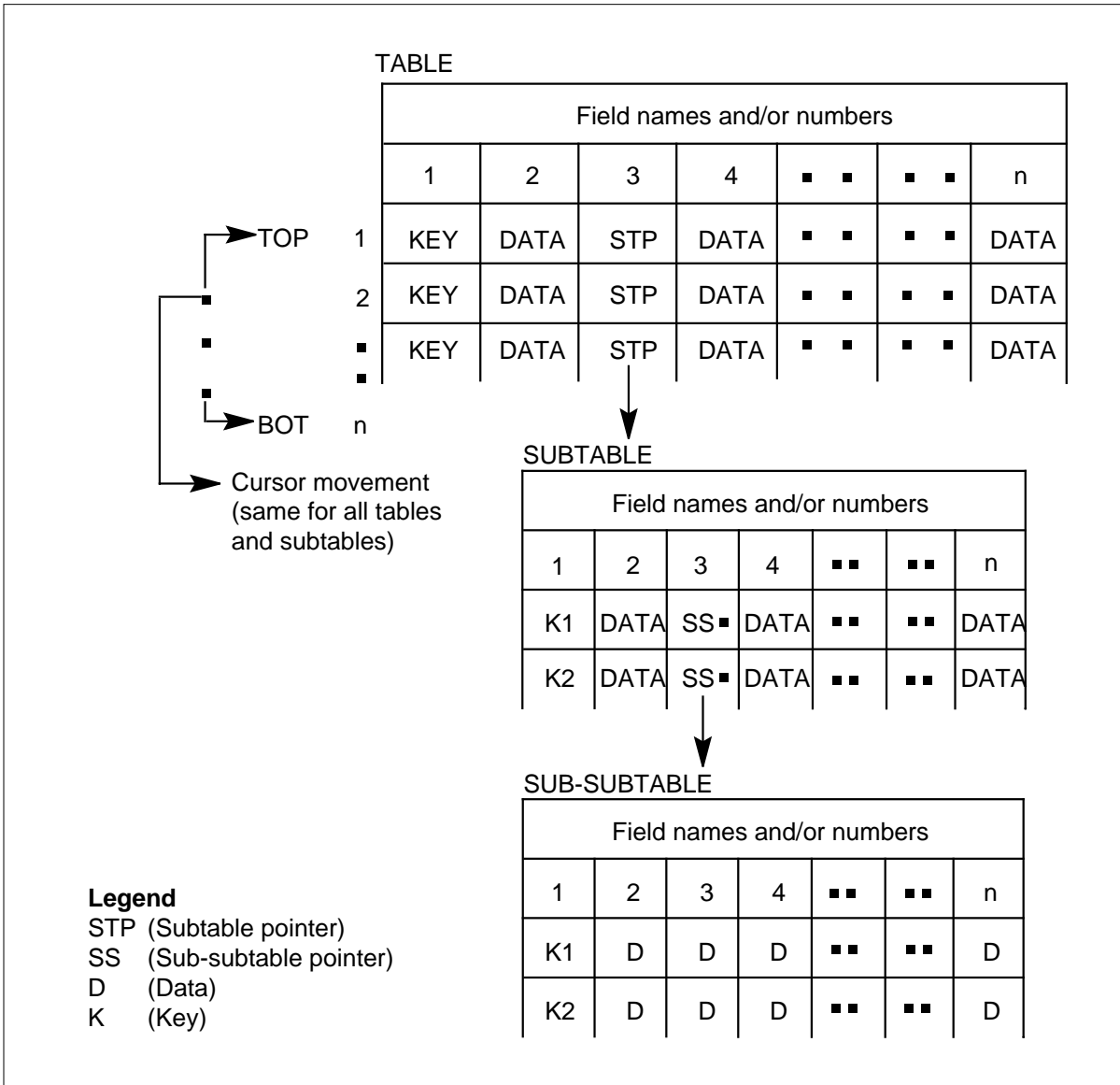
Each tuple is identified by a unique key.

A key always contains the first field. For most tables, the key comprises only one field. In other tables, more than one field of data is required to make the key unique. In this case, the first field plus one or more subsequent fields in the tuple are used to make up the key.

Tuples are referenced either by their key or by the table editor (TE) cursor. The cursor is an internal pointer to a tuple of a table. It can be moved by using TE commands, such as POSITION, LIST, BOTTOM, and TOP. Refer to the following table for a description of TE commands.

The tuple the cursor points to, at any given time, is called the current tuple.

Figure 2-1 Examples of table, subtable, and sub-subtable



Using the table editor

The TE is a set of commands used to modify the data contained in the DMS-100 control tables. The commands are entered at the MAP terminal.

Note: Only two subtable levels are supported.

The TE allows users to perform the following functions:

- add, delete, or change tuples or fields in a table or subtable
- list one or more tuples of a table or subtable

- move the cursor to display any tuple in a table or subtable
- display specified valid field values
- search for tuples containing specified field values

Procedures for datafilling any system

The datafill procedures in this section list the field and subfield names of the key tables that must be datafilled for any system. Explanations of each field and subfield are also provided. Examples of field entries are provided for most fields and subfields. The examples correspond to the example configuration shown in the previous table and to examples of tuples displayed at the end of each procedure.

Input prompts and prompting mode

A prompt is the system way of notifying the user the data entered is not complete or is not in defined parameters. When a prompt occurs, the user is provided the name of the required field or parameter. The user has the following options:

- input correct data entirely on the current line
- enter ABORT to exit the command and to exit the input and prompt mode
- enter invalid data, which causes the system to provide additional information about the field or parameter

If the tuple being datafilled has multiple list items, prompting continues until the maximum list length is reached or until a single dollar sign (\$) is entered.

Nonprompting mode



DANGER

Possible loss of service if using the NONPROMPT mode

In all tables which have fields with multiple entries such as, OPTCARD, EXECTAB, CSLINKTAB, and PSLINKTAB, do not use the NONPROMPT mode of datafill. All entries of a field must be entered in one entry when using the NONPROMPT mode. All entries that are not datafilled in the NONPROMPT mode will be deleted from the table. Operating company personnel will not be prompted for additional entries in a field unless they are in the PROMPT mode which steps through each individual value. The PROMPT mode is the only mode that should be used when making datafill changes to multiple entry fields.

All commands are initially processed in the nonprompting mode. After recognizing a valid command, one field value is processed at a time until either the end of the input line is reached (\$) or an error is found.

A tuple can be added all at once by stringing subsequent field values together, leaving a blank space between each field value, and by indicating the end of the string with a dollar sign (\$). If the information for one tuple exceeds one input line a plus sign (+) is placed as the last character on the line. This will enable the contents of the current line and the next line to be processed as a single input.

Activating changes to tables

After the TE checks that input data is complete and valid, a data modification order (DMO) is created. The DMO is then applied to change the appropriate table data.

Table editor commands

The following table lists all TE commands and provides a description for and parameters of each command.

Table 2-1 editor commands (Sheet 1 of 3)

Command	Description
TABLE <i>table name</i>	Opens the table <i>table name</i> .
ADD	Adds the tuple given as a parameter to the table or, if no parameters are given, prompts for each field for user input.

Table 2-1 editor commands (Sheet 2 of 3)

Command	Description
BOTtom	Positions the cursor at bottom of the table.
CHAnge	Changes the specified fields to the specified values. If no fields are specified, each field is prompted for user input.
COUNT condition	Counts the number of tuples in the table that meet specified conditions, and positions the cursor at the first tuple.
DELete KEY	Deletes the tuple containing the specified key. If no parameters are given, the current tuple is deleted.
DISplay	Displays the current tuple without the heading.
DOWn n	Moves the cursor down a specified number of tuples. A display of the tuple without the heading follows.
FIRST	Positions the cursor at the first tuple in the table or subtable, but does not display it.
HEADING	Displays the current tuple heading line or lines, showing tuple format.
HELp command name	Displays a brief description of the function of the desired TE command.
LAST	Positions the cursor at the last tuple in the table or subtable without displaying the tuple.
LIST n or all condition	Displays one or more tuples of the current table, as follows: <ul style="list-style-type: none"> • <i>n</i> is the number of tuples to be displayed, starting with the current tuple. • <i>all</i> includes all tuples of the current table displayed beginning at the first tuple, regardless of cursor position. • The condition command parameter is conditional and all tuples meeting the condition are listed. It is used in conjunction with the <i>n</i> and <i>all</i> parameters.
NEXT	Positions the cursor at the tuple following the current tuple but does not display it.
OVErride	Cancels the prompt that occurs when the CPUs are out-of-sync or when the journal file is not available.
POSition KEY	Positions the cursor at a specified tuple and causes the tuple to be displayed.

Table 2-1 editor commands (Sheet 3 of 3)

Command	Description
QUIT all	Exits the user from the current table if QUIT is entered. The parameter <i>all</i> causes the system to quit all tables accessed during the table editor session and returns directly to the command interpreter (CI) level of the MAP terminal.
RANge field	Displays the parameter range for the fields of the current tuple.
RETurn	Returns from sub-subtable to subtable or from a subtable to a main table.
SUBtable field name or field#	Opens and enters the subtable from a main table. The main table must be entered first before its subtable(s) can be accessed. If there is more than one subtable, the field name or the field number associated with it must be specified. When no parameters are entered, only one field points to a subtable and that subtable is entered.
TOP	Positions the cursor at the first tuple in the table and displays the tuple field data.
UP	Moves the cursor up by the specified number of tuples and displays the field data without headings.
VERify ON or OFF	Sets a verify mode, which delays execution of subsequent commands and lets a user check the display, as follows: <ul data-bbox="591 1129 1393 1268" style="list-style-type: none">• ON causes the system to prompt the user to confirm that the tuple addition, change, replacement, or deletion data is correct.• OFF causes the system to execute the command as entered, without confirmation from the user.

TR-303 Generic Interface

Functional group

Functional group: SMA00001

Feature package

Feature package: NTXT23AA (Generic TR-303 Generic Interface)

Release applicability

XPM08 and up

Prerequisites

To operate, TR-303 Generic Interface has the following prerequisites:

- Bilge, NTX000AA
- Common Basic, NTX001AA
- New Peripheral Maintenance, NTX270AA
- Local Features I, NTX901AA
- Subscriber Carrier Module, NTXF46AA
- XPM PLUS, NTXR34AA

Description

The multi-vendor interface (MVI) is an interface between the Digital Multiplex System-100 (DMS-100) and Bellcore TR-TSY-000303 (TR-303) complaint access vehicles called remote digital terminals (RDT).

The MVI allows connection to access vehicles conforming to the generic integrated digital loop carrier (IDLC) interface specified in Bellcore TR-303, as modified by the Northern Telecom Interface Specification (NIS A217-2).

The DMS-100 switch supports the Bellcore standard TR-303 for the IDLC systems access vehicle called an RDT. An IDLC system consists of a digital loop carrier (DLC) RDT, and a local digital switch (LDS).

The switch resources serving a RDT are called integrated digital terminals (IDT). MVI implements the IDT end of the generic IDLC TR-303 interface for Feature Set A (T1 interface), and uses the time-slot management channel (TMC) signaling method for generic RDTs.

MVI is implemented using the base hardware and software developed for the SMA2 product. MVI operates in a DMS-100 SuperNode environment. MVI supports the Enhanced Network (ENET) and Junctored Network (JNET). The NT40 system is not supported.

TR-303 Generic Interface (continued)

Translations table flow

TR-303 Generic Interface does not affect translations table flow.

Limitations and restrictions

The following limitations and restrictions apply to TR-303 Generic Interface:

- MVI RDTs support RDTLSG, RDTCON, RDTISD, and RDTMPY card codes. RDTLRB will be supported in the future. RDTEBS is not supported.
- Up to 255 MVI RDTs are supported by the DMS-100 switch with up to 100,000 lines can be engineered in this configuration.
- If field SHELF of a multi-vendor-interface RDT LEN is set to zero, the slot field of that RDT LEN cannot be set to zero.
- Frequency selective ringing is not supported.
- Semi-post paid coin lines—all attempts to datafill a line on a TR-303 RDT are rejected if the line class code is coin semi-postpay (CSP)
- To restore all ISDN lines provisioned at an RDT when the DMS-100 switch is upgraded to NA006 and up, data in field DSOPT must be converted to values for new fields CSPORT and CSCHNL in the read-only table RDTLT and then copied to the restore side. Field TIMESLOT in table RDTLT is copied to the restore side.

Interactions

TR-303 Generic Interface has no functionality interactions.

Activation/deactivation by the end user

TR-303 Generic Interface requires no activation or deactivation by the end user.

Billing

TR-303 Generic Interface does not affect billing.

Station Message Detail Recording

TR-303 Generic Interface does not affect Station Message Detail Recording.

TR-303 Generic Interface (continued)

Datafilling office parameters

TR-303 Generic Interface does not affect office parameters.

Office parameters used by TR-303 Generic Interface

Table name	Parameter name	Explanation and action
OFCOPT	XPM_MATE_DIAGNOSTICS_AVAILABLE	XMS-based peripheral module (XPM) mate diagnostics are activated by setting this parameter to Y. This ensures diagnostics are available to the resident switch. The XPM mate diagnostic feature enables the central control (CC) to diagnose a XPM unit through its mate XPM unit.
	VSLE_PRESENT	Visual screen list editing. When set to N (no), the analog services display interface (ADSI) line option must be assigned to the subscriber line in order for visual screen list editing (VSLE) to be accessed. When set to Y, VSLE is accessed without ADSI being assigned to the line.

Datafill sequence

Datafill sequence is unchanged for the TR-303 Generic Interface.

The "Datafill tables required for TR-303 Generic Interface" table lists the tables that require datafill to implement TR-303 Generic Interface. The tables are listed in the order they are datafilled.

Datafill tables required for TR-303 Generic Interface (Sheet 1 of 5)

Table	Purpose of table
CLLI	Common language location identifier. Identifies the maintenance and test trunks used in the SMA subsystem.
SITE	Site. Allows the DMS switch to recognize the remote equipment tied to the host.
PMNODES	Peripheral module nodes. Contains all nodes resident in all XPMs for a given site. This table is datafilled automatically by the system.
LTCINV	Line trunk controller inventory. Inventories various peripheral module (PM) types including the SMA2, and excluding P-side link assignments.
Note: This table is datafilled through SERVORD. No datafill procedure or example is provided. Refer to the "SERVORD" section for an example of using SERVORD to datafill this table.	

TR-303 Generic Interface (continued)

Datafill tables required for TR-303 Generic Interface (Sheet 2 of 5)

Table	Purpose of table
CARRMTC	Carrier maintenance control. Allows the DMS switch administration to datafill maintenance control information in peripherals, out-of-service limits, alarms, and system return-to-service occurrences.
PMLOADS	Peripheral module loads. Stores a load map between the load names and devices where the loads reside. This permits auto load to locate load files without the intervention of operating company personnel.
LTCPSINV	Line trunk controller P-side line inventory. Identifies the SMA2 module type, number, and port designation of the P-side links.
ALMSCGRP	Alarm scan group. Records the circuit equipment, location, type of card, and serves as a head table for the respective scan points.
ALMSDGRP	Alarm signal distributor group. Records the circuit equipment, location, and type of card and serves as a head table for the respective signal distributor points.
ALMSC	Alarm scan. Identifies the functions to be performed by each of the assigned scan points in the alarm scan groups.
ALMSD	Alarm signal distributor point. Identifies the function to be performed by each of the assigned signal distributor points in the alarm signal distributor groups.
DCHINV	D-channel handler inventory. Identifies the physical, service, and channel allocation characteristics of D-channel handler (DCH).
ISGDEF	ISDN service group definition. Identifies the ISDN service group (ISG) numbers, PM type, the services provided, and the allocation of services to channels.
LTGRP	Logical terminal group. Allows up to 32 logical terminal group definitions.
LTDEF	Logical terminal definition. Defines logical terminals within group and access privileges.
LTMAP	Logical terminal map. Maps the ISDN logical terminals to a LEN or terminal identifier (TEI). (See Note.)
SPECCONN	P-Side to P-side special connection. Defines special permanent dedicated connections through the SMA2.
RDTINV	Remote digital terminal. Allows the DMS switch administration to datafill RDTs and their corresponding IDTs. This table contains the C-side connectivity information and RDT configuration information.
<p>Note: This table is datafilled through SERVORD. No datafill procedure or example is provided. Refer to the "SERVORD" section for an example of using SERVORD to datafill this table.</p>	

TR-303 Generic Interface (continued)**Datafill tables required for TR-303 Generic Interface (Sheet 3 of 5)**

Table	Purpose of table
TMINV	Trunk module inventory. Identifies the trunk modules (TM) that contain test circuits that terminate test pairs connected to RDT lines.
TRKGRP	Trunk group. Identifies the test circuits associated with the maintenance and test trunks.
TRKSGRP	Trunk subgroup. Lists the supplementary information for each subgroup assigned to one of the trunk groups listed in table TRKGRP.
TRKMEM	Trunk member. Identifies the circuits associated with the test equipment used to test lines and trunks.
LINEATTR	Line attribute. Assigns line attributes to regular lines in table LENLINES, Meridian stations, and attendant consoles in the MDC translations tables.
LNINV	Line circuit inventory. Retains an inventory of subscriber lines and associated line cards.
RDTLT	Remote digital terminal line termination. Specifies the next operation to be performed by line object provisioning.
IBNLINES	IBN line assignment. Defines the line assignments for each MDC station number. (See Note.)
IBNFEAT	IBN line feature. Defines the line features assigned to the MDC lines listed in table IBNLINES. (See Note.)
CDCLENS	Customer data change line. Lists the line equipment numbers (LEN) assigned to a customer group.
KSETINV	Business set and data-unit inventory. Stores inventory data for each line card slot assigned to Meridian business sets and data units. (See Note.)
KSETLINE	Business set and data-unit inventory line assignment. Defines the data for directory number appearances on Meridian business sets and data units. (See Note.)
KSETFEAT	Business set and data-unit inventory line feature. Defines the line features assigned to business sets and data units listed in table KSETLINE. (See Note.)
Note: This table is datafilled through SERVORD. No datafill procedure or example is provided. Refer to the "SERVORD" section for an example of using SERVORD to datafill this table.	

TR-303 Generic Interface (continued)

Datafill tables required for TR-303 Generic Interface (Sheet 4 of 5)

Table	Purpose of table
LENLINES	<p>Line assignment. Lists the following data for each line:</p> <ul style="list-style-type: none"> • site name, if the line is remote • line equipment number • party where the directory number is assigned • ringing code assigned to the directory lines • directory number • signal type • index into the line attribute (LINEATTR) table • list of options <p>See Note.</p>
LENFEAT	Line feature. Lists the features assigned to a specific line in table LENLINES. (See Note.)
SCGRP	Scan group. List the physical location of the scan groups that provide SC points for line features.
SDGRP	Signal distributor group. List the physical location of the SD groups that provide SD points for line features.
LTDS	Line test desk signal distribution. Identifies the SD point used to drive the applique circuit during mechanized loop testing.
MTAMDRVE	Metallic test access minibar driver. Specifies the physical location of the metallic test access (MTA).
MTAVERT	Metallic test access vertical connection. Identifies the vertical connectivity to the MTA matrix.
MTAHORIZ	Metallic test access horizontal connection. Lists the assignment to a horizontal and horizontal group of metallic test access minibar drivers (MTAM).
AMAOPTS	AMA options. Controls the activation and scheduling of the recording options for automatic message accounting (AMA).
RESFEAT	Residential line feature. Contains the assignment of custom local area signaling services (CLASS) features for residential lines. (See Note.)
<p>Note: This table is datafilled through SERVORD. No datafill procedure or example is provided. Refer to the "SERVORD" section for an example of using SERVORD to datafill this table.</p>	

TR-303 Generic Interface (continued)

Datafill tables required for TR-303 Generic Interface (Sheet 5 of 5)

Table	Purpose of table
RESOFC	Residential line CLASS office data. Contains data pertaining to CLASS features. (See Note.)
TEXTPHRS	Test phrases. Contains the physical text phrases displayed on the customer premise equipment (CPE).
TEXTLOG	Logical display text. Contains the logical names of the physical text phrases.
SOFTKEY	Softkey. Specifies softkey information for application services.
DCSWDTYP	Deluxe spontaneous call waiting identification (DSCWID) type. Defines DSCWID treatment of subscriber lines.
Note: This table is datafilled through SERVORD. No datafill procedure or example is provided. Refer to the "SERVORD" section for an example of using SERVORD to datafill this table.	

Datafilling table CLLI

Common language location identifier (CLLI) codes are used to uniquely identify the far end of each announcement, tone, trunk group, test trunk, national milliwatt test lines, and service circuit.

The following table shows the datafill specific to TR-303 Generic Interface for table CLLI. Only those fields that apply directly to TR-303 Generic Interface are shown.

Datafilling table CLLI (Sheet 1 of 3)

Field	Subfield or refinement	Entry	Explanation and action
CLLI		see subfields	Common language location identifier. This 16-character field uniquely identifies the far end of each announcement, tone, trunk group, test trunk, national milliwatt test lines, and service circuit.
	PLACE	alphanumeric	Place. This four-character code identifies the name of the city or town at the far end of each group.
Note 1: Memory is allocated by the SIZE field in table data size (DATASIZE) for the entry with field DATSKEY equal to CLLI.			
Note 2: The maximum number of CLLI codes is 8192.			

TR-303 Generic Interface (continued)**Datafilling table CLLI (Sheet 2 of 3)**

Field	Subfield or refinement	Entry	Explanation and action
	PROV	alphanumeric	Province or state. This two-character code identifies the province or state at the far end of the trunk group.
	BLDG	alphanumeric	Building. This two-character code identifies the building number at the far end of the trunk group.
	TRAFUNIT	alphanumeric	Traffic unit. This three-character code identifies the destination of the traffic unit at the far end of the trunk group.
	SUFIX	alphanumeric	Suffix. This one-character code uniquely identifies trunk groups that terminate at the same CLLI location.
ADNUM		0 to a number one less than the size of table CLLI shown in table DATASIZE.	Administrative trunk group number. Enter a number from 0 to a number one less than the size of table CLLI shown in table DATASIZE. The value must be unique.
TRKGRSIZ		0-2047	Trunk group size. This four-character field is equal to the maximum quantity of trunk members expected to be assigned to the trunk group.
ADMININF		see subfields	Administrative information. This 32-character field is used by the operating company to record administrative information. The information in this field is not used by the switching unit. The recommended subfields are TRAFCLS, OFFCLS, and TRKGRTYP.
	TRAFCLS	alphanumeric	Trunk group traffic class. This field is optional input for administrative purposes only.
Note 1: Memory is allocated by the SIZE field in table data size (DATASIZE) for the entry with field DATSKEY equal to CLLI.			
Note 2: The maximum number of CLLI codes is 8192.			

TR-303 Generic Interface (continued)**Datafilling table CLLI (Sheet 3 of 3)**

Field	Subfield or refinement	Entry	Explanation and action
	OFFCLS	alphanumeric	Office class. This field is optional input for administrative purposes only.
	TRKGRTP	alphanumeric	Trunk group type. This field is optional input for administrative purposes only.
Note 1: Memory is allocated by the SIZE field in table data size (DATASIZE) for the entry with field DATSKEY equal to CLLI.			
Note 2: The maximum number of CLLI codes is 8192.			

Datafill example for table CLLI

The following example shows sample datafill for table CLLI.

MAP display example for table CLLI

CLLI	ADNUM	TRKGRSIZ	ADMININF
MTADRIVER	250	32	METALLIC_TEST_ACCESS_DRIVER
MONTALK	254	32	VERIFICATION
MJACK	257	256	METALLIC_JACK
MTU	259	32	METALLIC_TEST_UNIT

Datafilling table SITE

Table SITE contains data for the switching unit and for all remote locations connected to it. Before a LEN can be assigned and before a PM can be datafilled, table SITE must be datafilled to allow the DMS SuperNode switch to recognize the equipment.

The first entry in table SITE must be HOST for the host switching unit. The site names for the remote locations are defined by the operating company.

TR-303 Generic Interface (continued)

The following table shows the datafill specific to TR-303 Generic Interface for table SITE. Only those fields that apply directly to TR-303 Generic Interface are shown.

Datafilling table SITE (Sheet 1 of 2)

Field	Subfield or refinement	Entry	Explanation and action
NAME		Host or alphanumeric	Site name. Enter the site name assigned to the remote switching unit. The first character must be a letter. Site names may be up to four characters in length. PM type names cannot be used for site names. The first entry in this field is for the host switching unit.
LTDSN		00-99	LEN test desk site number. Enter a unique two-digit number required to dial the site that appears under field NAME.
MODCOUNT		0	Module count. Enter zero.
OPVRCLLI		Ver90 or alphanumeric	Operator verification CLLI. Enter the CLLI assigned to the operator verification trunk group at the remote location.
ALMDATA		see subfields	Alarm data. This field is for remote locations only and consists of subfields ALMTYPE, TMTYPE, TMNO, TMCKTNO, POINT, and CONTMARK.
	ALMTYPE	CR, MJ, MN, or blank	Alarm type. Enter the alarm type. This field is for remote locations. Where entry is for the host switching unit, leave blank.
	TMTYPE	RSM, RMM, or blank	Trunk module type. Enter the trunk module type (remote service module) where the miscellaneous signal distributor point assigned to the alarm is located. Where entry is for the host switching unit, leave blank.
	TMNO	0-99	Trunk module number. Enter the number assigned to the remote service module where the miscellaneous signal distributor point assigned to the alarm is located. Where entry is for the host switching unit, leave blank.
Note: Memory is automatically allocated for a maximum of 32 sites.			

TR-303 Generic Interface (continued)**Datafilling table SITE (Sheet 2 of 2)**

Field	Subfield or refinement	Entry	Explanation and action
	TMCKTNO	0-23	Trunk module circuit number. Enter the trunk module circuit on the remote service module where the miscellaneous signal distributor point assigned to the alarm is located. Where entry is for the host switching unit, leave blank.
	POINT	0-6	Point. Enter the signal distributor point number within the trunk module circuit number assigned to the alarm. Where entry is for the host switching unit, leave blank.
	CONTMARK	+ or \$	Enter a plus sign (+) when additional data for the site is specified on the next record. Otherwise, enter a dollar sign (\$) to terminate this vector.

Note: Memory is automatically allocated for a maximum of 32 sites.

Datafill example for table SITE

The following example shows sample datafill for table SITE.

MAP display example for table SITE

NAME	LTDSN	MODCOUNT	OPVRCLLI	ALMDATA
-----	HOST			
	00	4	VER90	\$

Datafilling table PMNODES

Table peripheral module nodes (PMNODES) is read only, used by the CM to control XPM unit node tables. Table PMNODES is automatically datafilled when entries are added or changed in inventory tables. An entry will exist in table PMNODES for all subtending nodes of each XPM. Fields are updated to reflect CM control of configuration data tables (CDT) in the XPM nodes. As nodes are deleted, holes may appear in the table. These cannot always be filled when a new node is added. Tuples in table PMNODES are managed so all subtending nodes must have a higher index than their head node.

Tuples in table PMNODES, are managed to enable subtending nodes to have a higher index than their head node. Attempts by operating company

TR-303 Generic Interface (continued)

personnel to update this table directly are rejected. XPM resources are checked when a tuple for a subtending node is added or changed in an inventory table. During a one night process (ONP) table PMNODES must be transferred before any hardware inventory tables. Warnings are displayed when a XPM does not have the table space, port, or terminal resources to support the new requirements.



CAUTION

An attempt to add or change tuples in any inventory table may be rejected by the system if table space or node resources are not available.

Attempted changes in the inventory tables with the table editor may be rejected. The system displays an explanation and possible corrective actions. Usually BSYing and RTSing a XPM, defragments the node tables, thus freeing required space. If XPM resources are not available, the following message is displayed.

The new node cannot be supported on SMA

ACTION: None, resources have been exceeded on this XPM.

TR-303 Generic Interface (continued)

The following table shows the datafill specific to TR-303 Generic Interface for table PMNODES. Only those fields that apply directly to TR-303 Generic Interface are shown.

Datafilling table PMNODES (Sheet 1 of 3)

Field	Subfield or refinement	Entry	Explanation and action
TABKEY		0 to 4095 0 to 117	Table key. Two-part key, separated by a space, identifying the XPM where the unit node table is located. The first part is host external node number. The second part is internal index number. Examples: The first key of an LTC with an external node number of 25 would be 25 1. The key of the first XPM attached to the LTC would be 25 2.
EXTNDNUM		0 to 4095	External node number. External number assigned by CM to the XPM identified in field TABKEY. Example: If the first XPM in the example above was an RCC2 with an external node of 33 the key of 25 2 would reference XPM external node 33 in the LTC node tuple. The RCC2 would also have a node tuple key of 33 1 to represent that node.
NODETYPE		alphanumeric	Node type of XPM. Generic type of PM node. Examples: LTC_NODE, RCC_NODE, LCM_NODE, and RCS_NODE.
PMTYPE		alphanumeric	PM type. Specific PM type assigned to the node. Examples: RCC2, LCME, SMSR, and LTC.
LEVEL		0 to 15	PM level. The number of device levels the XPM node is separated from the messaging host. Begins at level 0 for messaging (head) XPMs. Examples: An LCME at level 2, attached to the RCC2 at level 1, which is attached to the HOST LTC at level 0. The same LCME would be at level 1 of the RCC2 tuple at level 0.
MSGHOST		0 to 4095	Messaging host. External node responsible for transferring messages to this node. A messaging host must be capable of transferring messages. Examples: LTC and RCC. Examples of XPMs not capable of being a messaging host are: RCU and SMSR.

TR-303 Generic Interface (continued)

Datafilling table PMNODES (Sheet 2 of 3)

Field	Subfield or refinement	Entry	Explanation and action
PHYSHOST		0 to 4095	Physical host. External node where this XPM node is physically attached. Example: The LCME is physically attached to RCC2 at external node 33.
PORTS		0 to 127	Number of ports. Total number of P-side ports in the physical host required by this XPM node.
STPORT		0 to 255	Starting port. First P-side port in the physical host used by this XPM node.
TERMS		0 to 4095	Number of terminals. Total number of terminals in the physical host required by this XPM node.
STTERM		0 to 8675	Starting terminal. First terminal in the physical HOST used by this XPM node.
PROTOCOL		alphanumeric	Message protocol. Type of message protocol used by the physical host to node links. Examples: MDS30, MDMSX, MHDLC.
MS		M or S	Master or slave. M if this node contains the master clock.
IPML		Y or N	Inter-peripheral message link (IPML). Y if this node is configured as part of an IPML.
MODE		T or P	Table entry mode. Entries in table are made by terminal (T) or port (P) indexing.
SLLCON		Y or N	Site line load control. Y if this node is at a site using Essential Line Service Protection (ESP) or other site line load control features.
NT6X28		N	Uses NT6X28 card. Y if this XPM uses the NT6X28 card. The NT6X28 signaling interface card is used on the International Digital Trunk Controller (IDTC). Always enter N.
LCMLGMEM		Y or N	LCM large memory. Y if this XPM is an LCM with large memory (256k bytes).
RSVPORTS		Y or N	Reserved ports. Y if this XPM has ports that are reserved for messaging.

TR-303 Generic Interface (continued)**Datafilling table PMNODES (Sheet 3 of 3)**

Field	Subfield or refinement	Entry	Explanation and action
RSVTERMS		Y or N	Reserved terminals. Y if this XPM has terminals reserved for messaging.
MATENODE		Y or N	Mate node. Y if this node is part of a dual configuration.
PACKED		Y or N	Packed internal tables. Y if internal node tables are packed on this node. Prior to this feature the node table was compressed when the XPM was RTS with the NODATASYNC option. Compression will now only happen when both units of an XPM are taken out-of-service (OOS) and loaded by the CM.
SUPPCDM		Y Y	Support configuration data table (CDT). Y for each unit if CDT management is supported.
CMINCTRL		Y or N	CM node control. Y if the node is under CM control.

Datafill example for table PMNODES

The following examples show datafill for an SMA2 node with an RDT node connected to the SMA2.

MAP display example for table PMNODES (SMA2 tuple)

```
Table: PMNODES
TABKEY  EXTNDNUM  NODETYPE  PMTYPE  LEVEL  MSGHOST  PHYSHOST  PORTS
33      1           33      LTC_NODE  SMA2    0         33         33      16
STPORT  TERMS  STTERM  PROTOCOL MS  IPML  MODE  SLLCON NT6X28  LCMLGMEM  RSVPORTS
0       641     1       MDMSX   S     N     P     N       N         N         Y
RSVTERMS  MATENODE  PACKED  SUPPCDT  CMINCTRL
Y         N         Y       YY       Y
```

MAP display example for table PMNODES (SMA2 to IDT tuple)

```
Table: PMNODES
TABKEY  EXTNDNUM  NODETYPE  PMTYPE  LEVEL  MSGHOST  PHYSHOST  PORTS
33      2           74      IDT_NODE  IDT     1         33         33      48
STPORT  TERMS  STTERM  PROTOCOL MS  IPML  MODE  SLLCON NT6X28  LCMLGMEM  RSVPORTS
18      641     642     MDMSX   S     N     P     N       N         Y         N
RSVTERMS  MATENODE  PACKED  SUPPCDT  CMINCTRL
N         N         Y       YY       Y
```

TR-303 Generic Interface (continued)

Note: Each SMA2 node in the link capable of messaging would have a tuple in table PMNODES to address the IDT.

Datafilling table LTCINV

Table line trunk controller inventory (LTCINV) contains the inventory data, excluding P-side link assignments addressed in table LTCPSINV, for various PM types, including the SMA2.

The following table shows the datafill specific to TR-303 Generic Interface for table LTCINV. Only those fields that apply directly to TR-303 Generic Interface are shown.

Datafilling table LTCINV (Sheet 1 of 6)

Field	Subfield or refinement	Entry	Explanation and action
LTCNAME		see subfields	Line trunk controller name. This field contains subfields XPMTYPE and XPMNO.
	XPMTYPE	SMA2	Peripheral module type. Enter the type of PM.
	XPMNO	0-127	Peripheral module number. The range is 0-127 because the SMA2 is part of the host office.
ADNUM		0-4095	Administration number. This number is used by the engineering and administrative data acquisition system for data collection (EADAS/DC) to identify nodes within the DMS-100 Family switch. This number remains fixed over dump and restore.
FRTYPE		CMVI, MVIE or MVDD	Frame type. Enter the frame type, CMVI for the cabinet-based version, MVIE for the frame based version or MVDD for the multi-vendor double density version, where the PM equipment is mounted.
FRNO		0-511	Frame number. Enter the frame number of the SMA2.
SHPOS		06 or 34 for CMVI; 16 or 44 for MVIE	Shelf position. Enter the position of the shelves on the frame in inches above the floor level.
		16, 30, 44 or 58 for MVDD	
Note: Memory is automatically allocated for a maximum of 128 tuples for table LTCINV.			

TR-303 Generic Interface (continued)**Datafilling table LTCINV (Sheet 2 of 6)**

Field	Subfield or refinement	Entry	Explanation and action
FLOOR		0-99	Floor. Enter the floor where the PM equipment frame is located.
ROW		A-H, J-N, P-Z, AA-HH, JJ-NN, and PP-ZZ	Row. Enter the row on the floor where the PM equipment frame is located.
FRPOS		0-99	Frame position. Enter the position in the row of the PM equipment frame.
EQPEC		alphanumeric	Equipment product engineering code. Enter the PEC of the PM.
LOAD		alphanumeric	Load name. Enter the eight character name given to the issue of PM software.
EXEC		see subfields	Executive table. This field contains subfields TRMTYPE, EXEC, and CONTMARK.
	TRMTYPE	alphanumeric	Terminal type. Enter the type of terminal models to be used. POTS is used for regular lines, RMM_TERM for remote maintenance trunks, ABTRK for regular trunks, R1_TERM for DTC300 trunks, and MX5X09 and M5X12 for Meridian 9 and 12 button sets.
	EXEC	alphanumeric	Executive programs. Enter the set of executive programs required for the PM specified in the TRMTYPE field.
	CONTMARK	+ or \$	Continuation mark. Enter a plus sign (+) when the vector continues on the next line. Otherwise, enter \$ to end the vector.
Note: Memory is automatically allocated for a maximum of 128 tuples for table LTCINV.			

TR-303 Generic Interface (continued)

Datafilling table LTCINV (Sheet 3 of 6)

Field	Subfield or refinement	Entry	Explanation and action
CSLNKTAB		see subfields	<p>C-side link table.</p> <p>For switches equipped with the old junctored network (JNET), this field contains subfields NMPAIR, NMPORT, and CONTMARK.</p> <p>Note: Changes to fields with multiple entries should be made in the PROMPT mode only.</p> <p>For switches equipped with the enhanced network (ENET), this field contains subfields ENSHELF, ENSLOT, ENLINK, ENDS30 and CONTMARK.</p>
	NMPAIR	0-31	Network module pair number. Enter the network link where the PM is assigned, corresponding to the provisioned C-side links of the SMA2.
	NMPORT	0-63	Network port number. Enter the network port corresponding to the preceding link.
	ENSHELF	0-7	ENET shelf number. Enter the shelf number where the SMA2 is assigned.
	ENSLOT	10 to 16 25 to 32 or 13 to 19	ENET slot number. Enter the crosspoint slot number where the SMA2 is assigned, corresponding to the provisioned C-side links of the SMA2. For a SuperNode SE switching unit, enter a value between 13 and 19.
	ENLINK	0-18	ENET link number. Enter the link on the crosspoint where the SMA2 is assigned, corresponding to the provisioned C-side links of the SMA2.
	ENDS30	0-15	ENET DS30. This field defaults to 0 (zero) if the link is a DS30.
	CONTMARK	+ or \$	Continuation mark. Enter a plus sign (+) when the vector continues on the next line. Otherwise, enter a dollar sign (\$) to end the vector.
Note: Memory is automatically allocated for a maximum of 128 tuples for table LTCINV.			

TR-303 Generic Interface (continued)

Datafilling table LTCINV (Sheet 4 of 6)

Field	Subfield or refinement	Entry	Explanation and action
OPTCARD		alphanumeric	Optional card. This is a vector of up to ten entries. For the SMA2, slot 16 must be used for the ISP card, though the actual EISP card resides in slot 4. Slots 6 and 7 can only be used for the universal tone receiver (UTR) card. The CLASS modem resource (CMR) card can only be plugged in slot 5. Note: Changes to fields with multiple entries should be made in the PROMPT mode only. MSGMX76 HOST must be datafilled for the SMA2 platform. When datafilling the MSGMX76 card, the system prompts for the MX76LOC described in subfield MX76LOC. Examples are ISP16, UTR6, and CMR5.
	MX76LOC	HOST or REM	NTMX76 location. If the card is located on a host PM, enter HOST. REM is not a valid entry. Any attempt to enter REM generates an error message on the screen and the system returns to the default of HOST.
	CMRLOAD	alphanumeric	CLASS modem resource load. This is a vector of up to eight characters. Enter the CMR software load.
CONTMARK		+ or \$	Continuation mark. Enter + when the vector continues on the next line. Otherwise, enter \$ to end the vector.
TONESSET		NORTHAM	Tone set. Enter the tone set appropriate for the switch being datafilled.
PECS6X45		AX74AA	6X45 equipment PECs. One PEC is required for each unit of the SMA2. Enter the PEC for unit 0 first. The PEC datafilled for a unit must correspond to the minimum firmware capabilities in the processor complex of each unit. The PEC for the SMA2 is AX74AA.

Note: Memory is automatically allocated for a maximum of 128 tuples for table LTCINV.

TR-303 Generic Interface (continued)**Datafilling table LTCINV (Sheet 5 of 6)**

Field	Subfield or refinement	Entry	Explanation and action
E2LOAD		alphanumeric	Electrically erasable programmable read-only memory. Contains the eight character name of the load file that is loaded in the NTAX74AA EEPROM.
OPTATTR		\$	Optional attribute. This vector is datafilled for digital terminal controller (DTC) PMs only. Enter a \$ to end the vector.
PEC6X40		6X40 AC, AD, FA, or FB	6X40 equipment PEC. Enter the version of the 6X40 card in the peripheral. The default is 6X40AA. The value entered is displayed in error messages when a faulty card is detected. Note: NT6X40AD and NT6X40FB cards provide enhanced diagnostic capabilities. If PEC6X40 datafill is set to the NT6X40AC or NT6X40FA version of the card, the new diagnostics capabilities will not be initiated. The CM will treat the interface as NT6X40AC/NT6X40FA regardless of the card installed.
EXTINFO		see subfield	Extension shelf information for the CMVI and MVIE versions only. This field consists of subfield EXTSHelf. The MVDD version does not support an extension shelf.
	EXTSHelf	Y or N	Extension shelf. If the PM is a CPM-based host peripheral, for example a GPP, and it is equipped with an extension shelf, enter Y (yes) and datafill the fields below. Otherwise, enter N (no). No other datafill is required. The default value for this field is N.
	EXTFRtYP	CMVI, MVIE, or NIL	Extension frame type. Enter the type of frame where the extension shelf is housed.
	EXTFRNO	0 to 511	Extension frame number. Enter the number of the frame in which the extension shelf is housed.
Note: Memory is automatically allocated for a maximum of 128 tuples for table LTCINV.			

TR-303 Generic Interface (continued)**Datafilling table LTCINV (Sheet 6 of 6)**

Field	Subfield or refinement	Entry	Explanation and action
	EXTSHPOS	20 for CMVI; 30 for MVIE	Extension shelf position number. Enter the extension shelf position number.
	EXTFLOOR	0 to 99	Extension shelf floor number. Enter the number of the floor where the extension shelf is located.
	EXTROW	A-Z, AA-ZZ excluding I and O	Extension shelf row number. Enter the character identifying the row in which the extension shelf is located.
	EXTFRPOS	0 to 99	Extension shelf frame number. Enter the number indicating the frame position where the shelf is housed.
	EXTEQPEC	MX86AB	Extension shelf equipment PEC. Enter the extension shelf equipment PEC.
	EXTSIDE	L or R	Extension shelf side. Enter extension shelf side: L (left) or R (right).

Note: Memory is automatically allocated for a maximum of 128 tuples for table LTCINV.

Datafill example for table LTCINV

The following example shows sample datafill for table LTCINV.

MAP display example for table LTCINV

```

LTCNAME
  ADNUM  FRTYPE  FRNO  SHPOS  FLOOR  ROW  FRPOS  EQPEC  LOAD
                                EXECTAB
                                CSLNKTAB
                                OPTCARD
TONESET          PECS6X45    E2LOAD
                                OPTATTR
PEC6X40          EXTINFO
-----
SMA2  0
      1000  CMVI  0   18      1   E   2  MX85AB  XM208BA
                                (  POTS  POTSEX) (  KEYSET  KSETEX)$
      (0 47) (0 55) (1 47) (1 55) (0 62)(1 62)(0 5)(1 5)$
      (ISP16) (UTR6) (UTR7) (MSGMX76  HOST) (CMR5) (CMR07A)$
NORTHAM  AX74AA  AX74AA  AX74XE01  $
      6X40FA      Y  CMVI  0  3  2  A  22  MX86AB  R

```

TR-303 Generic Interface (continued)

Datafilling table CARRMTC

Table carrier maintenance (CARRMTC) allows the DMS SuperNode switch administration to datafill maintenance control information in peripherals, out-of-service limits for alarms, and system return-to-service occurrences.

Table CARRMTC contains the attributes of DS-1 links, such as the line coding and frame formats along with maintenance control information.

A carrier, by definition, maintains communication on links connecting DMS peripherals to channel banks, DMS peripherals to remote DMS peripherals, or remote-to-remote DMS peripherals.

Up to 16 entries exist in table CARRMTC for each type of peripheral capable of providing carrier links in the switch. These entries are used in field CARRIDX of table LTCPSINV when datafilling carriers.

The following checks are made between table CARRMTC and table LTCPSINV:

- When a carrier index (CARRIDX) is datafilled in table LTCPSINV, an entry for the PM type, in this case the SMA2, must be present in table CARRMTC.
- When an entry is deleted from table CARRMTC, the entry cannot be referenced by any carriers in table LTCPSINV. Otherwise, the deletion command is rejected.
- When an existing entry in table CARRMTC is changed, table LTCPSINV is checked to determine if the entry is referenced by in-service carriers. If so, the change command is rejected, and a list of in-service carriers is displayed.

The DMS SuperNode switch adds the first tuple for SMA2 to table CARRMTC automatically during initial program load (IPL) or first restart after IPL. The entry is designated as index 0 and has the value DEFAULT in the TEMPLNM field, and default values for other fields.

This tuple cannot be deleted, and only fields ES, SES, and thresholds for frame and slip losses, can be changed. Tuples other than the default tuple must be added manually before they can be referenced in table LTCPSINV.

These tuples can be deleted only if no DS-1 carriers are associated with them. Tuples can be changed in table CARRMTC only if the associated DS-1 carriers are manually busy or offline.

TR-303 Generic Interface (continued)

The following table shows the datafill specific to TR-303 Generic Interface for table CARRMTC. Only those fields that apply directly to TR-303 Generic Interface are shown.

Datafilling table CARRMTC (Sheet 1 of 4)

Field	Subfield or refinement	Entry	Explanation and action
CSPMTYPE		SMA2	C-side node PM type. Enter the PM type of the node on the C-side of the carrier link.
TMPLTNM		Default	Template name. Enter the template name (up to 16 characters) for the PM. This entry also appears in the field CARRIDX of table LTCPSINV. The default value is DEFAULT. Note: Datafill as NO_YELLOW_ALM to activate values in fields BEROL and BERML.
RTSML		0-255	Return to service maintenance limit. Enter the number of times within the audit interval, a carrier may be returned to service by the system before a warning is issued. Value 255 disables this feature.
RTSOL		0-255	Return to service out-of-service limit. Enter the number of times within the audit interval, a carrier may be returned to service by the system, before it is placed permanently out of service. Value 255 disables this feature.
CONTMARK		+	Continuation mark. Enter + for record to be continued on the next line.
ATTR		see subfield	Attribute. This field contains subfield SELECTOR.
	SELECTOR	DS1	Selector. Enter carrier type DS1.
	CARD	NTMX81AA	Card. Enter the product engineering code (PEC) of the DS-1 interface card used. The PEC for the DS-1 interface card in the SMA2 is NTMX81AA. NTMX81AA provides 64 kb/s clear-channel capability required for MBS services operating in B8ZS mode.

TR-303 Generic Interface (continued)**Datafilling table CARRMTC (Sheet 2 of 4)**

Field	Subfield or refinement	Entry	Explanation and action
	VOICELAW	MU_LAW	Voice law. Enter the voice law used in the carrier. A_LAW is used mainly in international switches. MU_LAW is used mainly in North American switches.
	FF	ESF	Frame format. Enter extended super frame format (ESF) in this field. The SMA2-RDT subsystem uses a 24-frame format.
	ZLG	ZCS or B8ZS	Zero logic. Enter ZCS for zero code suppression. A byte of zeroes is transmitted with a 1 in the least significant bit position. This results in an incorrect transmission for data in the SMA2-RDT subsystem, and causes minor noise for speech. ZCS precludes the use of integrated services digital network (ISDN). Enter B8ZS for bipolar 8-bit zero substitution. B8ZS is required for 64 kb/s clear-channel capability for ISDN services.
	BERB	BPV or CRC	Bit error rate base. Enter CRC for cyclic redundancy check violations. BER calculations based on CRCs detect problems on the entire DS-1 path. Note: CRC must be entered for generic TR-303.
	DLK	NILDL	Data link. Currently, only NILDL is supported.
	IAT	N	Inhibit alarm transmit. Enter N for the IAT field for the SMA2-RDT configuration.
	LCGAST	250	Local carrier group alarm set threshold. Enter value for the threshold in units of 10 ms. Entry of 250 is recommended. The range is 0-9999.
	LCGACL	1000	Local carrier group alarm clear threshold. Enter value for the threshold in units of 10 ms. Entry of 1000 is recommended. The range is 0-9999.

TR-303 Generic Interface (continued)

Datafilling table CARRMTC (Sheet 3 of 4)

Field	Subfield or refinement	Entry	Explanation and action
	RCGAST	1000	Remote carrier group alarm set threshold. Enter value for the threshold in units of 10ms, in other words, the entry is multiplied by 10. This field is set to 1000 providing a threshold value of 10 000 ms or 10 s. This value overrides datafill. The range is 0-9999.
	RCGACL	1000	Remote carrier group alarm clear threshold. Enter value for the threshold in units of 10ms, in other words, the entry is multiplied by 10. This field is set to 1000 providing a threshold value of 10 000ms or 10 s. This value overrides datafill. The range is 0-9999.
CONTMARK		+	Continuation mark. Enter plus sign (+) for record to be continued on the next line.
	AISST	1-9999	Alarm indication signal set threshold. Enter value for the threshold in units of 10 ms.
	AISCL	1-9999	Alarm indication signal clear threshold. Enter value for the threshold in units of 10 ms. The range is 1-9999.
	BEROL	3-6	Bit error rate out-of-service limit. Enter the bit error rate out-of-service limit expressed as the negative of the exponent of 10 (10E-n). For example, 3 represents a 1 in 1000 bit error rate. Note: If field TMPLTNM is datafilled as DEFAULT, the system sets this value to 3 and overrides datafill. If field TMPLTNM is datafilled as NO_YELLOW_ALM, this value is user-controlled for any value in the range.
	BERML	4-7	Bit error rate maintenance limit. Enter the bit error rate maintenance limit expressed as the negative of the exponent of 10 (10E-n). Note: If field TMPLTNM is datafilled as DEFAULT, the system sets this value to 6 and overrides datafill. If field TMPLTNM is datafilled as NO_YELLOW_ALM, this value is user-controlled for any value in the range.

TR-303 Generic Interface (continued)

Datafilling table CARRMTC (Sheet 4 of 4)

Field	Subfield or refinement	Entry	Explanation and action
	ES	0-9999	Error second threshold. Enter value for the threshold in units of 10 ms.
	SES	0-9999	Severe error second threshold. Enter value for the threshold in units of 10 ms.
	FRAMEML	0-9999	Frame maintenance limit. Enter the maintenance limit for frame loss.
	FRAMEOL	0-9999	Frame loss limit. Enter the out-of-service limit for frame loss. FRAMEOL should be larger than FRAMEML.
	SLIPML	0-9999	Slip maintenance limit. Enter the maintenance limit for slip.
	SLIPOL	0-9999	Slip out-of-service limit. Enter the out-of-service limit for slip. SLIPOL should be larger than SLIPML.

BpV handling

Bipolar violation (BpV) levels for the RDT are hard-coded in SMA2 software to be 1E-3 (a 1 in 1000 bit error rate) for the out-of-service limit and 1E-6 for the maintenance (MTC) limit.

When field TMPLTNM is datafilled as DEFAULT, RDT BpV levels are compared to these hard-coded values to determine if an alarm should be raised.

RDT BpV levels are user-controllable when field TMPLTNM is datafilled as NO_YELLOW_ALM. In this case, RDT BPV levels are compared with the values datafilled in fields BEROL and BERMN to determine if an alarm should be raised.

Datafill example for table CARRMTC

The following example shows sample datafill for table CARRMTC.

MAP display example for table CARRMTC

```

CSPMTYPE TMPLTNM RTSML RTSOL ATTR
-----
SMA2 DEFAULT 255 255 DS1 NTMX81AA MU_LAW ESF B8ZS CRC NILDL
N 250 1000 1000 1000 150 1000 3 6 864 320 17 511 4 255
    
```

TR-303 Generic Interface (continued)

Datafilling table PMLOADS

Table PMLOADS stores the device location of every PM loadfile. This permits the XPM automatic loading feature to locate load files without the intervention of operating company personnel.

Table PMLOADS lists the active and backup loadfiles. The active loadfile is always the default load used with the LOADPDM command and most system activities. The backup loadfile is used if there is a problem in loading or returning to service the active loadfile. The backup loadfile is always the unpatched loadfile that Northern Telecom shipped. The active and backup loadfiles are used when applying and removing patches.

Table PMLOADS stores data for

- the name of the active loadfile, which is the default load used with the LOADPDM command and most system initiated activities
- the name of the backup loadfile, which is the load used if there is a problem in loading or returning to service the active loadfile. The backup loadfile is always the unpatched loadfile shipped with the SMA2.
- the file locations
- the update active loadfile field, which indicates if the site wants the active fileid updated automatically. The feature allows the patched loadfile to be loaded into the XPM should a reload be necessary which simplifies reload and recovery of the XPM. The active file information is updated through loadfile patching, if loadfile patching is enabled.

The active and backup files are used by the system as part of loading and recovery.

The XPM load files must be datafilled in table PMLOADS before they can be datafilled in table LTCINV. Table LTCINV enforces this rule.

Note: An exception to this rule occurs during initial datafill, and during dump and restore. During these times, tuples in table PMLOADS are automatically datafilled when LTCINV tuples are datafilled.

Pre-patched XPM loads**Pre-patched XPM loads background**

Pre-patched XPM loads (PPXLs) are XPM loadfiles that have corrective patches built into the loadfile. PPXLs are incremental loads that are built using patch updates. The patch updates were originally used to create patch files which have been released to the field. Hence there is no functional or technical difference between a regular XPM load with patches versus a PPXL where the

TR-303 Generic Interface (continued)

patches have been incorporated into the load. In summary, PPXLs are analogous to CM loads that have patches built in, based on date of shipment.

Implementation of PPXLs

At the beginning of each PPXL loadfile there is a 1K data block containing the patch IDs for the patches that have been included within the PPXL. Even though the patches have been built into the PPXL, the corresponding patch files for each patchid listed in the 1K data block must be present when the PPXL is datafilled in table PMLOADS.

When the PPXL is datafilled in table PMLOADS, the loadset is modified if one already exists for the base load, or the loadset is initially created if the base load is new to the DMS-100 switch.

Note: Loadsets are used to group all peripheral units loaded with the same load together. To view all loadsets on the DMS-100 switch, access the PATCHER CI level and enter the command string INFORM PMALL.

After the PPXL has been added to table PMLOADS, it can be loaded manually, or automatically, by the system recovery controller (SRC). When the PPXL is loaded, by either method, the patching performed after loading the PPXL is reduced, or eliminated entirely, because most or all of the patches have already been included in the load.

Once the PPXL is loaded, it can have additional patches applied to it or removed from it exactly in the same manner, as a regular XPM load can. Also, any patches built into the PPXL can be removed, as long as their corresponding patch files are present.

Any patches added or removed following loading of a PPXL are automatically applied or removed upon subsequent reloads of the PPXL.

PPXL Naming Convention

PPXL file names have `<date>` appended to the end of their corresponding base load name. For example, a PPXL load file created for base load ECL03BX would be named ECL03BX_941129. The base load name, however, always remains the same. Base loads can be identified as any load not having the `<date>` suffix.

The inherent value then becomes the preservation of the patch stream with the ability to up-issue a PPXL as required. A PPXL's vintage can always be identified using the date identifier.

TR-303 Generic Interface (continued)

PPXL storage requirements

When preparing to load PPXLs, Telcos are advised to double their XPM load storage requirements to accommodate the PPXLs. PPXLs require that the PPXL loadfile be stored on the ACTVOL device and the base load file be stored on the BKPVOL device.

Loading a PPXL

There are two methods of adding PPXLs to an office. The first is for upgrading an office to a new base load lineup, that is, when the base loadname is not currently in table PMLOADS. The second method is for adding PPXLs to offices that already have the base loadname in table PMLOADS. For example, XM207BH (the existing loadname) is appended to XM207BH_950105 (the PPXL added to the baseload). The two methods follow:

Note 1: PPXLs are only supported on BCS36 or higher CM loads.

Note 2: PATCH JCK19 must be applied to the CM before continuing.

Upgrading the base load

To load a PPXL in an office where the baseload is new to the office, use the following procedure:

- 1 Copy the base loadfile and the PPXL loadfiles to the disk volumes to be used for PM loads.

Note: Both the base load and the PPXL load should be copied to two disk volumes for redundancy.

- 2 Copy the patches associated with the PPXL loads to the same disk volume used in the step 1. A list of patches associated with each PPXL load is included in the load tape shipment. After the PPXL file is present on disk, obtain a list of patches included in the PPXL by typing

```
>XPMLFP
```

and pressing the Enter key.

```
>PATCHLIST FILE ppxl_filename
```

and pressing the Enter key.

where

ppxl_filename

is the filename of the PPXL loaded added to the baseload

- 3 Add a new tuple for the base load to table PMLOADS. Enter the base load for the LOADNAME, the base loadname for the ACTFILE and the base load name again for the BKPFIL.
- 4 Add the base loadname to the appropriate inventory table, for example LTCINV.
- 5 Edit the tuple added in step 3 to change the ACTFILE field from the base loadfile name to the PPXL filename. See the datafill example for table PMLOADS to view this tuple.

TR-303 Generic Interface (continued)

- 6 Set the loadset against both units of the XPM by typing
>PATCHER
and pressing the Enter key.
>SET loadname PM pm_type device_no unit_no
and pressing the Enter key.
where
loadname
is the name of the loadfile
pm_type
is the type of PM requiring the loadset
device_no
is the device number with a range of 0-255
unit_no
is the unit number, 0 or 1
- 7 Load the PPXL into each unit of the XPM by typing
>BSY UNIT unit_no
and pressing the Enter key.
>LOADPM UNIT unit_no
and pressing the Enter key.
>RTS UNIT unit_no
and pressing the Enter key.
where
unit_no
is the unit number of the XPM to be loaded
- 8 Perform a warm SwAct of the XPM and repeat step 7.
Note 1: Once loaded, the XPM may have additional patches applied or removed in the same manner used with XPM loads in the past. Also, any patches built into the PPXL may be removed from the load as long as the actual patch file is present on disk.
Note 2: Any patches added or removed following loading of a PPXL are automatically applied or removed upon subsequent reloads of the PPXL.
Note 3: Non-PPXL patches are not removed when the PPXL is reloaded since there is no need to remove them because the removed patches are already out of the loadset.

Adding PPXLs to an existing PM load lineup

To add PPXLs to an existing XPM load lineup, use the following procedure:

- 1 Verify all patch_ids associated with the PPXL are present on the disk volume identified in table PMLOADS, field ACTVOL. If not present, copy the patches from tape to the correct volume. A list of the patches contained in each PPXL

TR-303 Generic Interface (continued)

is included with the PM tape shipment. Once the PPXLs are copied to disk, list the patches in the PPXL by typing

>XPMLFP

and pressing the Enter key.

>PATCHLIST FILE ppxl_filename

and pressing the Enter key.

where

ppxl_filename

is the filename of the PPXL loaded to disk

- 2 Copy the PPXL file (filename_date) to the disk volume used in step 1.
- 3 Copy the baseload to the disk volume identified in table PMLOADS, field BKPVOL.
- 4 Modify table PMLOADS as follows: If the XPM base loadname does not currently exist in table PMLOADS add a new tuple using the previous "Upgrading the base load" procedure. Otherwise, change the ACTFILE field to the PPXL filename (filename_date). At this point the loadset is upgraded if one currently exists or one will be created if not.
- 5 Set the loadset against both units of the XPM by typing

>PATCHER

and pressing the Enter key.

>SET loadname PM pm_type device_no unit_no

and pressing the Enter key.

where

loadname

is the name of the loadfile

pm_type

is the type of PM requiring the loadset

device_no

is the device number with a range of 0-255

unit_no

is the unit number, 0 or 1

- 6 Each unit of the XPM may now be loaded with the PPXL by typing

>BSY UNIT unit_no

and pressing the Enter key.

>LOADPM UNIT unit_no

and pressing the Enter key.

>RTS UNIT unit_no

and pressing the Enter key.

where

unit_no

is the unit number of the XPM to be loaded

TR-303 Generic Interface (continued)

- 7 Perform a warm SwAct of the XPM and repeat step 6.

Note 1: Once loaded, the XPM may have additional patches applied or removed in the same manner used with XPM loads in the past. Also, any patches built into the PPXL may be removed from the load as long as the actual patch file is present on disk.

Note 2: Any patches added or removed following loading of a PPXL will be automatically applied or removed upon subsequently reloads of the PPXL.

The following table shows the datafill specific to TR-303 Generic Interface for table PMLOADS. Only those fields that apply directly to TR-303 Generic Interface are shown.

Datafilling table PMLOADS

Field	Subfield or refinement	Entry	Explanation and action
LOADNAME		alphanumeric	Peripheral module load name. Enter the XPM load file name. The range is up to eight characters.
ACTFILE		alphanumeric	Active load file name. The name of the active XPM loadfile. This could be the original loadfile or a patched loadfile (PPXL). Range is up to 32 characters.
ACTVOL		alphanumeric	Active volume. Identifies the device where the active loadfile is stored. Range is the set of disk drive unit (DDU) volumes and system load module (SLM) disks that are available to the CM (that is, S00DXPM). Range is up to 16 characters.
BKPFILE		alphanumeric	Backup load file name. Identifies the name of the backup XPM loadfile. It should be the same name as the LOADNAME field. Range is up to 32 characters
BKPVOL		alphanumeric	Backup volume. The device where the backup loadfile is stored. Range is the set of DDU volumes and SLM disks that are available to the CM (that is, S00DXPM). Range is up to 16 characters.
UPDACT		alphanumeric	Update active filename. Currently not used. The default value is N.

TR-303 Generic Interface (continued)

Datafill example for table PMLOADS

The following example shows sample datafill for table PMLOADS.

MAP display example for table PMLOADS

LOADNAME	ACTFILE	ACTVOL	BKPFIL	BKPVOL	UPDACT

XM208BN					
XM208BH_970805		S001DXPM			
XM208BH		S001DXPM			N

Datafilling table LTCPSINV

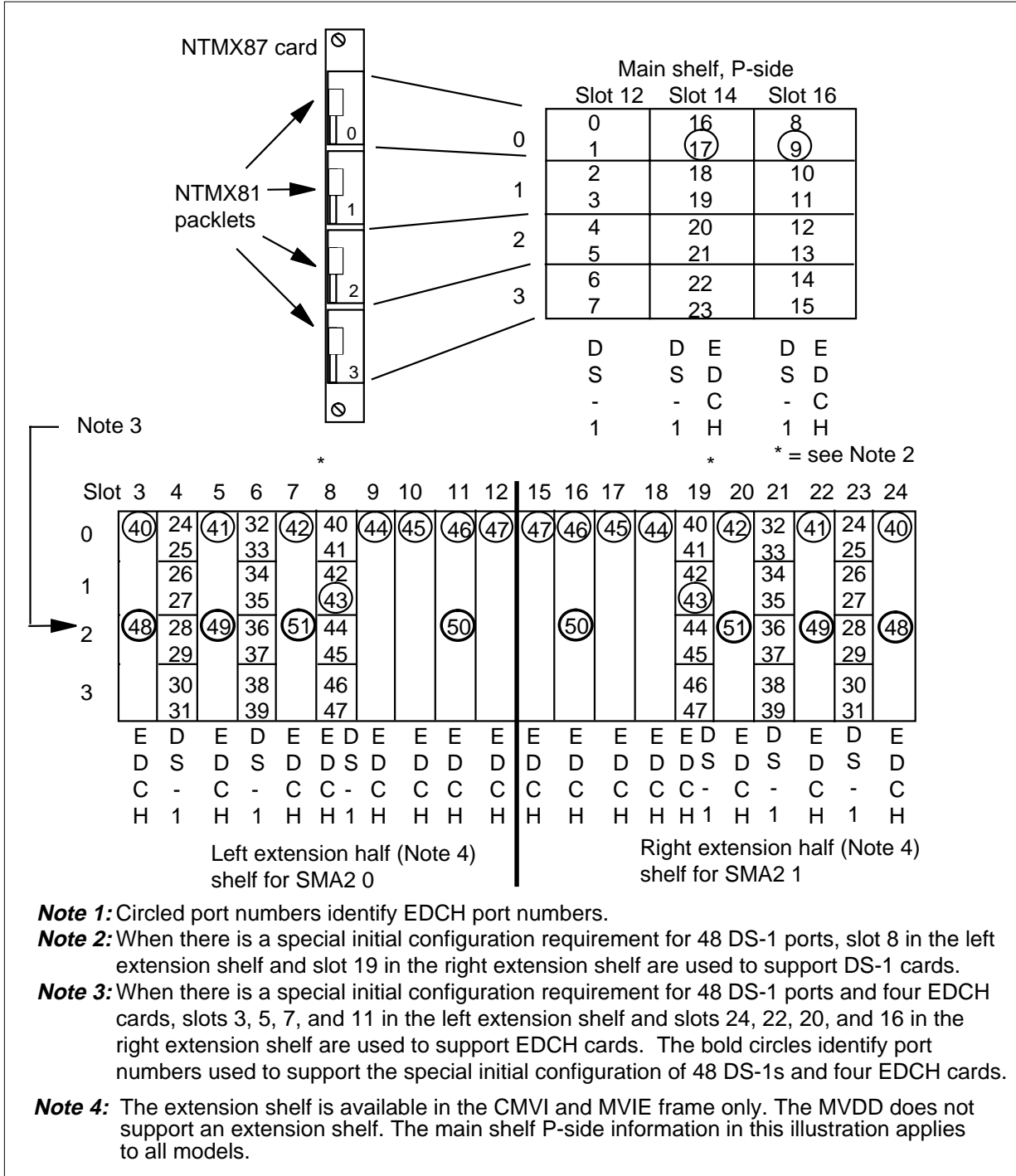
The line trunk controller P-side link inventory (LTCPSINV) table lists the PM type and number and the port designation of the P-side links for each bay associated with a SMA2 unit. The following capacities apply to datafilling SMA2:

- The SMA2 provides up to 54 P-side ports where flexible combination of DS-1 and EDCH services can be defined. The index of the LTCPSINV table is the same as for LTCINV. An SMA2 default tuple is automatically added to LTCPSINV table when an SMA2 is datafilled in LTCINV table. DS-1 links located in the extension shelf (CMVI and MVIE frame only) can be datafilled only if an extension shelf is datafilled in table LTCINV.
- The SMA2, without the extension shelf, supports up to 2 EDCH cards which are datafilled on P-side ports 9 and 17. When the extension shelf is datafilled, the SMA2 supports up to 6 EDCH cards which are datafilled on P-side ports 9, 17, and 40-47 or 43-45 and 47-51. Ports 48 through 51 are reserved for the 48 DS-1 + 4 EDCH cards configuration and are not recommended to be used unless this is a special initial requirement. Upgrades to this configuration are not supported because they are service affecting.
- The SMA2 supports up to 24 DS-1 links without the extension shelf, and up to 48 DS-1 links with the extension shelf.

The following figure identifies the physical locations of the EDCH and DS-1 cards and the P-side links that connect to them.

TR-303 Generic Interface (continued)

P-side port provisioning



TR-303 Generic Interface (continued)

The following table shows datafill specific to TR-303 Generic Interface for table LTCPSINV. Only those fields that apply directly to TR-303 Generic Interface are shown.

Datafilling table LTCPSINV (Sheet 1 of 2)

Field	Subfield or refinement	Entry	Explanation and action
LTCNAME		see subfields	Line trunk controller name. This field contains subfields XPMTYPE and XPMNO.
	XPMTYPE	SMA2	Peripheral module type. Enter the type of PM. This entry must match what is in LTCINV.
	XPMNO	0-255	Peripheral module number.
PSLNKTAB		see subfields	P-side link table. This field contains subfields EXP_PSIDES, PSLINK, PSDATA, AREASELCT, CARRIDX, ACTION, and CONTMARK. Vector from 0-53. Note: Changes to fields with multiple entries should be made in the PROMPT mode only.
	EXP_PSIDES	Y or N	Expanded P-sides platform indicator. If the shelf support more than 20 P-side links, enter Y (yes) and datafill field EXP_TAB. Enter N (no) if the shelf supports up to 20 P-side links.
	EXP_TAB	Vector of up to 54 multiples. See explanation.	Expansion table. This field consists of subfields PSLINK and PSDATA. If EXP_PSIDES is datafilled as Y, this is a vector of up to 54 multiples. See subfields. If EXP_PSIDES is datafilled as N, this is a vector of up to 20 multiples. See subfields.
	PSLINK	0-53	P-side link. Enter the P-side port number.
	PSDATA	see subfield	P-side data. Consists of subfield AREASELCT.
	AREASELCT	DS1	Area select. DS1 is entered for DS-1 type interface cards.
Note: Memory is automatically allocated for a maximum of 128 tuples for table LTCPSINV.			

TR-303 Generic Interface (continued)**Datafilling table LTCPSINV (Sheet 2 of 2)**

Field	Subfield or refinement	Entry	Explanation and action
	CARRIDX	DEFAULT	Carrier index. Enter the same value for the template name in table CARRMTC. The default value is DEFAULT. The value entered here can be any value added in table CARRMTC. All names, other than DEFAULT, must be added manually, or by datafill groups, in table CARRMTC before they are available here.
	ACTION	Y or N	Action. Enter Y if the carrier should be removed from service when the out-of-service limit for frame, slip, errored-second, or severe errored-second is exceeded. Otherwise, enter N.
	CONTMARK	+ or \$	Continuation mark. Enter + when the vector continues on the next line. Otherwise, enter \$ to end the vector.
Note: Memory is automatically allocated for a maximum of 128 tuples for table LTCPSINV.			

Datafill example for table LTCPSINV

The following example shows sample datafill for table LTCPSINV.

TR-303 Generic Interface (continued)**MAP display example for table LTCPSINV**

LTCNAME	PSLNKTAB

SMA2	0
Y	(0 DS1 DEFAULT N) (1 DS1 DEFAULT N) (2 DS1 DEFAULT N)
	(3 DS1 DEFAULT N) (4 DS1 DEFAULT N) (5 DS1 DEFAULT N)
	(6 DS1 DEFAULT N) (7 DS1 DEFAULT N) (8 DS1 DEFAULT N)
	(9 DS1 DEFAULT N) (10 DS1 DEFAULT N) (11 DS1 DEFAULT N)
	(12 DS1 DEFAULT N) (13 DS1 DEFAULT N) (14 DS1 DEFAULT N)
	(15 DS1 DEFAULT N) (16 DS1 DEFAULT N) (17 DCH)
	(18 DS1 DEFAULT N) (19 DS1 DEFAULT N) (20 DS1 DEFAULT N)
	(21 DS1 DEFAULT N) (22 DS1 DEFAULT N) (23 DS1 DEFAULT N)
	(24 DS1 DEFAULT N) (25 DS1 DEFAULT N) (26 DS1 DEFAULT N)
	(27 DS1 DEFAULT N) (28 DS1 DEFAULT N) (29 DS1 DEFAULT N)
	(30 DS1 DEFAULT N) (31 DS1 DEFAULT N) (32 DS1 DEFAULT N)
	(33 DS1 DEFAULT N) (34 DS1 DEFAULT N) (35 DS1 DEFAULT N)
	(36 DS1 DEFAULT N) (37 DS1 DEFAULT N) (38 DS1 DEFAULT N)
	(39 DS1 DEFAULT N) (40 DCH) (41 DCH) (42 DCH) (43 NILTYPE)
	(44 NILTYPE) (45 NILTYPE) (46 NILTYPE) (47 NILTYPE)
	(48 NILTYPE) (49 NILTYPE) (50 NILTYPE) (51 NILTYPE)
	(52 NILTYPE) (53 NILTYPE) \$

Datafilling table ALMSCGRP

The alarm scan group (ALMSCGRP) table records the circuit equipment, location, and type of circuit card containing scan points.

The following table shows the datafill specific to TR-303 Generic Interface for table ALMSCGRP. Only those fields that apply directly to TR-303 Generic Interface are shown.

Datafilling table ALMSCGRP (Sheet 1 of 2)

Field	Subfield or refinement	Entry	Explanation and action
SCGROUP		0-255	Scan group. Enter the scan group number.
TMTYPE		alphanumeric	Trunk module type. Enter the type of trunk module where the circuit is mounted.
TMNO		0-255	Trunk module number. Enter the number of the trunk module where the circuit is mounted.

TR-303 Generic Interface (continued)

Datafilling table ALMSCGRP (Sheet 2 of 2)

Field	Subfield or refinement	Entry	Explanation and action
TMCKTNO		0-23	Trunk module circuit number. Enter the trunk module circuit number where the circuit is assigned.
CARDCODE		alphanumeric	Card code. Enter the PEC of the alarm card.

Datafill example for table ALMSCGRP

The following example shows sample datafill for table ALMSCGRP.

MAP display example for table ALMSCGRP

SCGROUP	TMTYPE	TMNO	TMCKTNO	CARDCODE
0	MTM	1	1	3X82AA
1	MTM	3	1	3X82AA
2	MTM	1	7	3X84AA
3	MTM	1	10	0X10AA
.
15	RSM	1	7	0X10AA
.
21	RMM	2	11	0X10AA

Datafilling table ALMSDGRP

Table alarm signal distributor group (ALMSDGRP) records the circuit equipment, location and type of circuit card containing signal distributor points.

The following table shows the datafill specific to TR-303 Generic Interface for table ALMSDGRP. Only those fields that apply directly to TR-303 Generic Interface are shown.

Datafilling table ALMSDGRP (Sheet 1 of 2)

Field	Subfield or refinement	Entry	Explanation and action
SDGRP		0-255	Signal distributor group. Enter the signal distributor group number.
TMTYPE		alphanumeric	Trunk module type. Enter the type of trunk module where the circuit is mounted.

TR-303 Generic Interface (continued)**Datafilling table ALMSDGRP (Sheet 2 of 2)**

Field	Subfield or refinement	Entry	Explanation and action
TMNO		0-255	Trunk module number. Enter the number of the trunk module where the circuit is mounted.
TMCKTNO		0-23	Trunk module circuit number. Enter the trunk module circuit number where the circuit is assigned.
CARDCODE		alphanumeric	Card code. Enter the PEC of the alarm card.

Datafill example for table ALMSDGRP

The following example shows sample datafill for table ALMSDGRP.

MAP display example for table ALMSDGRP

SDGROUP	TMTYPE	TMNO	TMCKTNO	CARDCODE
0	MTM	1	0	3X82AA
1	MTM	3	0	3X82AA
2	MTM	1	6	3X84AA
4	MTM	1	4	2X57AA
5	MTM	1	5	2X57AA
6	MTM	1	18	2X57AA
7	MTM	1	19	2X57AA
8	MTM	6	18	2X57AA
9	MTM	6	19	2X57AA
10	MTM	9	18	2X57AA
11	MTM	9	19	2X57AA
.
22	MTM	12	18	2X57AA
23	MTM	12	19	2X57AA

Datafilling table ALMSC

The alarm scan (ALMSC) table associates a scan point function with an actual scan point and specifies which SD points should be operated when that scan point is activated.

The LOGIC field for the RDTALRMCO SC point function should always be Y. This indicates the functionality is fixed (in the software) and is not datafilled.

The SCGROUPs must be datafilled in table ALMSCGRP before datafilling scan points. The value for field SCGROUP must be 4 or higher. Although 1

TR-303 Generic Interface (continued)

through 3 are valid entries, these numbers are reserved for DMS system scan alarms such as common audible fail and office alarm unit fail.

The following table shows the datafill specific to TR-303 Generic Interface for table ALMSC. Only those fields that apply directly to TR-303 Generic Interface are shown.

Datafilling table ALMSC (Sheet 1 of 2)

Field	Subfield or refinement	Entry	Explanation and action
FUNCTION		alphanumeric	Function. Enter the alarm function.
SCGROUP		0-255	Scan group. Enter the scan group where the scan point belongs.
POINT		0-6	Scan point. Enter the scan point number within the scan group.
NORMALST		0-1	Normal state. Enter the normal state of the scan point. Entry values are 0, if the scan point is normally off or open, and 1, if the scan point is normally on or closed.
REPORT		Y or N	Report. Enter Y if an alarm report is to be logged. Otherwise, enter N.
ALM		CR, MJ, MN, or NA	Alarm. Enter the type of alarm to be activated. Entry values are CR (critical alarm), MJ (major alarm), MN (minor alarm), and NA (no alarm).
LOGIC		see subfields	Logic. This field consists of subfields LOGIC, SDFUNCT, ALMGRP, ALMXFR, and CONTMARK.
	LOGIC	Y or N	Logic. Enter Y if the logic associated with the function is fixed. Otherwise enter N.
	SDFUNCT	alphanumeric	Signal distributor function. Enter the signal distributor function or functions associated with a specific scan point.
	ALMGRP	Y or N	Alarm grouping. Enter Y if the alarm function is to be implemented when the alarm grouping key is activated. Enter N if the alarm function is to be implemented at all times, regardless of the alarm grouping key.

TR-303 Generic Interface (continued)**Datafilling table ALMSC (Sheet 2 of 2)**

Field	Subfield or refinement	Entry	Explanation and action
	ALMXFR	Y or N	Alarm transfer. Enter Y if the alarm function is to be implemented when the alarm transfer key is activated. Otherwise enter N.
	CONTMARK	+ or \$	Continuation mark. Where the record is other than the last for a specific scan point, enter +, which indicates that additional data for the scan point is specified in the next record. Where the record is the last for a specific scan point, enter a dollar sign (\$).

Datafill example for table ALMSC

The following example shows sample datafill for table ALMSC.

MAP display example for table ALMSC

FUNCTION	SCGROUP	POINT	NORMALST	REPORT	ALM	LOGIC
RDOTALRMCO	4	1	0	N	NA	Y \$

Datafilling table ALMSD

Table alarm signal distributor point (ALMSD) associates a SD point function with an actual SD point. Of the 13 SD point functions, eight are used as indicators, as to the RDT is raising a particular alarm, and three are used as indicators as to the severity of the alarm being raised.

There is a one-to-one relationship between the eight functions and the eight possible enumerated "Which SD" SD points in the SDPOINTS field of table RDTINV.

The AUDIBLE field should always contain an N for the SD points associated with RDT alarms. The table control system enforces this requirement. A Y in this field indicates an audible alarm cutoff switch should turn the SD points off. This should not be the case for RDT SD points.

The SDGROUPS must be datafilled in table ALMSDGRP before datafilling SD points. The value for field SDGROUP must be 4 or higher. Though 1 through 3 are valid entries, these numbers are reserved for DMS switch alarms such as alarm battery MTM fail.

TR-303 Generic Interface (continued)

SD points are electrical relays controlled by DMS switch software. These relays are usually connected to lights, bells, or remote telemetry monitoring devices. To activate SD points in response to RDT alarms, severity-indicating SD points must be datafilled in table ALMSD.

These severity-indicating SD points are the following:

- RDTCRIT—operated when critical alarms are present at a RDT
- RDTMAJOR—operated when major alarms are present at a RDT
- RDTMINOR—operated when minor alarms are present at a RDT

Eight SD point functions are reserved for use by RDT alarm handling software to indicate which RDT has an alarm. These “Which-RDT” SD point functions are RDTSD1 through RDTSD8.

The SD points are used to indicate which RDT has the alarms shown by the severity-indicating SD points. Each RDT can be set to activate a unique combination of SD points by datafilling the combination in field SDPOINTS in table RDTINV.

Additional SD point functions now exist: RDTACO and RDTWARN. When RDTACO is active, it indicates there are active RDT alarms not displayed because the alarm cutoff function is enabled.

RDTWARN is activated by software alarm RDTWRN. RDTWRN is similar to software alarms RDTCRT, RDTMJ, and RDTMN. RDTWARN is automatically datafilled in table SFWALARM during initial program load, and is set to activate by default.

Once datafilled, RDTWARN *cannot* be deleted from table ALMSD, unless it is first removed from the logic of table SFWALARM. RDTWARN indicates the presence of warning-level alarms at the RDT RDTWARN is similar to other severity-indicating RDT SD points: RDTCRIT, RDTMAJOR and RDTMINOR.

Note: RDTACO and RDTWARN are optional. They do not need to be datafilled before SD points are datafilled in table RDTINV.

SD points RDTACO and RDTWARN can only be datafilled if there are available circuits on SD circuit cards NT2X57.

TR-303 Generic Interface (continued)

The following table shows datafill specific to TR-303 Generic Interface for table ALMSD. Only those fields that apply directly to TR-303 Generic Interface are shown.

Datafilling table ALMSD

Field	Subfield or refinement	Entry	Explanation and action
FUNCTION		alphanumeric	Function. Enter the alarm function. The entry is alphanumeric with up to 16 characters. RDTACO and RDTWARN are new functions.
SDGROUP		0-255	Signal distributor group. Enter the signal distributor group where the SD point belongs. For SD points RDTACO and RDTWARN, SDGROUP should be 4 or higher. The 0-3 are reserved for system alarms.
POINT		0-7	Signal distributor point. Enter the SD point number within the signal distributor group.
NORMALST		0-1	Normal state. Enter the normal state of the SD point. Entry values are 0 if the SD point is OFF, or open, normally and 1 if the SD point is ON, or CLOSED, normally. For RDTACO and RDTWARN SD points, 0 is appropriate.
AUDIBLE		Y or N	Audible. Enter Y if the signal distributor point is to be reset when the audible alarm reset key is operated. Otherwise, enter N. RDTACO and RDTWARN SD points are not allowed to be audible. Only N is acceptable for these values.
LAMPTEST		Y or N	Lamp test. Enter Y if the SD point is to be included in the lamp test. Otherwise, enter N.

Datafill example for table ALMSD

The following example shows sample datafill for table ALMSD.

TR-303 Generic Interface (continued)

MAP display example for table ALMSD

FUNCTION	SDGROUP	POINT	NORMALST	AUDIBLE	LAMPTEST
RDTSD1	4	1	0	N	Y
RDTSD2	4	2	0	N	Y
RDTSD8	4	3	0	N	Y
RDTACO	4	4	0	N	Y
RDTWARN	4	5	0	N	Y

Datafilling table DCHINV

The D-channel handler inventory (DCHINV) table describes the physical, service, and channel allocation characteristics of enhanced D-channel handlers provisioned in the SMA2. The inventory information includes the following:

- DCH identification number
- type and number of the host PM
- product equipment code of the DCH
- load file name of the DCH
- port used by the DCH

The following table shows the datafill specific to TR-303 Generic Interface for table DCHINV. Only those fields that apply directly to TR-303 Generic Interface are shown.

Datafilling table DCHINV (Sheet 1 of 2)

Field	Subfield or refinement	Entry	Explanation and action
DCHNO		0-255	D-channel handler number. Enter the external identification number used by the system to represent a specific D-channel handler.
PMTYPE		SMA2	Peripheral module type. Enter the PM type where the DCH is located.
PMNO		0-255	Peripheral module number. Enter the PM number of the SMA2 where the DCH is located.
DCHPEC		NTBX02BA	DCH product engineering code. Enter the PEC of the DCH card. For SMA2, enter NTBX02BA.

TR-303 Generic Interface (continued)**Datafilling table DCHINV (Sheet 2 of 2)**

Field	Subfield or refinement	Entry	Explanation and action
LOAD		alphanumeric	Load file name. Enter the DCH load name.
PORT		0-63	DS1 port. Enter the DS-1 port number used by the DCH.

Datafill example for table DCHINV

The following example shows sample datafill for table DCHINV.

MAP display example for table DCHINV

DCHNO	PMTYPE	PMNO	DCHPEC	LOAD	PORT
0	SMA2	0	BX02BA	EDH07BH	9
1	SMA2	0	BX02BA	EDH07BH	17

Datafilling table ISGDEF

The ISDN service group definition (ISGDEF) table contains information on ISG numbers, the PM type, the services provided, and the allocation of services channels.

The following table shows the datafill specific to TR-303 Generic Interface for table ISGDEF. Only those fields that apply directly to TR-303 Generic Interface are shown.

Datafilling table ISGDEF (Sheet 1 of 2)

Field	Subfield or refinement	Entry	Explanation and action
ISGNO		0-255	ISDN service group number. Enter the identification number used to assign the D-channel to a DCH.
PMTYPE		SMA2	Peripheral module type. Enter the PM that supports DCH services.
PMNO		0-255	Peripheral module number. Enter the PM number of the SMA2 where the DCH is located.

TR-303 Generic Interface (continued)

Datafilling table ISGDEF (Sheet 2 of 2)

Field	Subfield or refinement	Entry	Explanation and action
SERVICE		BRA or PD	Enter the services provided by the ISDN service group. Up to three entries are allowed; use a \$ sign to terminate this field if fewer than three entries are made.
CHNLTAB		see subfields	<p>Channel information. This field is a vector with up to 32 entries specifying the functions of each channel. It is comprised of subfields DCHNL and CHNLTYPE. Use a dollar sign (\$) sign to terminate this field if fewer than 32 entries are made.</p> <p>Note: All BD channels must be assigned in descending order starting at 31, while BRA channels are assigned in ascending order starting at 0. Therefore, the order of datafill for BD and BRA channels is restricted as follows:</p> <p>For one night process (ONP), the warning message "BD channels must be higher than any BRA channels" is displayed to inform operating company personnel of the incorrect data ordering in the tuple transferred. However, the tuple is accepted by the table on the new side.</p> <p>For non-ONP, the error message "BD channels must be higher than any BRA channels" is displayed to inform operating company personnel of the incorrect data ordering in the tuple and the tuple is rejected.</p>
	DCHNL	0-31	D-channel. Enter the external identifier for the D-channel.
	CHTYPE	see subfield	Channel type. This field consists of subfield CHNLTYPE and refinements.
	CHNL-TYPE	NIL, RESERVED, BRA or BD	Channel type. Enter the service the D-channel provides.

Datafill example for table ISGDEF

The following example shows sample datafill for table ISGDEF.

TR-303 Generic Interface (continued)**MAP display example for table ISGDEF**

ISGNO	PMYTPE	PMNO	SERVICE	CHNL/TAB
3	SMA2	5	BRA\$	
(0 RESERVED) (1 BRA) (2 BRA) (3 BRA) (4 BRA) (5 BRA)				
(6 BRA) (7 BRA) (8 BRA) (9 BRA) (10 BRA) (11 BRA)				
(12 BRA) (13 BRA) (14 BRA) (15 BRA) (16 BRA) (17 BRA)				
(18 BRA) (19 BRA) (20 BRA) (21 BRA) (22 BRA) (23 BRA)				
(24 BRA) (25 BRA) (26 BRA) (27 BRA) (28 BRA) (29 BRA)				
(30 BD) (31 BD) \$				

Datafilling table LTGRP

Table logical terminal group (LTGRP) defines up to 32 logical terminal groups. One group is permanently defined as ISDN and cannot be deleted.

Other group names may be defined in alpha-numeric combinations of eight characters. Each group supports up to 1022 logical terminal identifiers for a table total of up to 32,704 logical terminal identifiers (32 x 1022).

Note: A logical terminal group must be entered in this table before logical terminals can be specified in other tables.

The following table shows the datafill specific to TR-303 Generic Interface for table LTGRP. Only those fields that apply directly to TR-303 Generic Interface are shown.

Datafilling table LTGRP (Sheet 1 of 2)

Field	Subfield or refinement	Entry	Explanation and action
GROUP		alphanumeric	Logical terminal group. Enter the name of the logical group of terminals.

TR-303 Generic Interface (continued)

Datafilling table LTGRP (Sheet 2 of 2)

Field	Subfield or refinement	Entry	Explanation and action
GROUPNO		0-31	Group number. Enter a number that corresponds to the group name. The default number for logical terminal group ISDN is 0. For data packet network terminal groups, enter a number between 1-15.
OPTIONS		SAPI16 or \$	Options. Enter SAPI16 for packet or circuit switched terminals. If the SAPI16 option is not specified, no packet-switched terminals can be datafilled for the group.

Datafill example for table LTGRP

The following example shows sample datafill for table LTGRP.

MAP display example for table LTGRP

GROUP	GROUPNO	OPTIONS
ISDN	0	(SAPI16)
SMA2	1	(SAPI16)

Datafilling table LTDEF

Table logical terminal definition (LTDEF) defines logical terminals and terminal access privileges. The following access privileges can be assigned to a logical terminal:

- voice and circuit-switched data on a B-channel (B)
- low-speed packet-switched data on a D-channel (D)
- high-speed packet data on a B-channel (PB)
- combined circuit-switched and D-channel packet data (BD)
- 2-B circuit switching (2B)

TR-303 Generic Interface (continued)

The following table shows the datafill specific to TR-303 Generic Interface for table LTDEF. Only those fields that apply directly to TR-303 Generic Interface are shown.

Datafilling table LTDEF (Sheet 1 of 2)

Field	Subfield or refinement	Entry	Explanation and action
LTKEY		see subfields	Logical terminal key.
	LTGRP	alphanumeric	Logical terminal group. Enter the logical terminal group. The group ISDN is already defined.
	LTNUM	0-1022	Logical terminal number. Enter a logical terminal number.
LTAP		B, D, BD, PB, 2B	<p>Logical terminal access privilege. Enter one of the following access privileges: B for circuit-switching, D for D-channel packet-switching, BD for combined circuit-switching and D-channel packet-switching, PB for B-channel packet switching, or 2B for 2B circuit switching.</p> <p>Note: BD is used for functional sets. B is used for ISDN Meridian feature transparency (MFT).</p>
CLASSREF		BRAFS, or BRAMFT	Logical terminal class of service. Enter a set of services allowed for the logical terminal. Range is BRAFS for BRA functional sets, and BRAMFT for functional terminals.
	OPTION	see list of options	<p>This field contains a list of options that are assigned, based on the value given to the field LTCLASS.</p> <p>The BRAFS options are SPIDSFX, CACH, DEFLTERM, NOVOICE, NOVBD, NOCMD, NOPMD, DTEI, SPIDSPX, EKTS, PVC, UATEI, and UNATEI. The BRAMFT options are DTEI, SPIDSFX, UATEI, and PVC.</p>
		CACH	Call appearance handling feature. Enter CACH to enable CACH. Datafill EKTS if datafilling this option.
		EKTS	Electronic key telephone service. Enter EKTS to indicate electronic key telephone service.

TR-303 Generic Interface (continued)**Datafilling table LTDEF (Sheet 2 of 2)**

Field	Subfield or refinement	Entry	Explanation and action
		NOCMD	No circuit mode data calls. Enter NOCMD if circuit mode data calls are disallowed.
		DEFLTERM	Default logical terminal. If a phone has a default service profile, and consequently does not require a service profile to be downloaded, enter DEFLTERM (for example, for a non-initializing terminal).
		NOPMD	No packet mode data calls. Enter NOPMD if packet mode data calls are disallowed.
		NOVBD	No voice band data calls. Enter NOVBD if voice band data calls are disallowed.
		NOVOICE	No voice calls. Enter NOVOICE if voice calls are disallowed.
	SPIDSFX	see subfield	Service profile identifier suffix. This field consists of subfield SPID_SUFFIX.
	SPID-SUFFIX	numeric	Service profile identifier suffix. Enter a name that uniquely identifies the subscriber on a dynamic terminal endpoint identifier (TEI) terminal.
		DTEI	Dynamic terminal endpoint identifier. Enter DTEI. An entry in this field is required if subfield SPIDSFX is datafilled.
	PVC	see subfields	Protocol version control. This field consists of subfields VERSION and ISSUE.
	VERSION	FUNCTIONAL	Protocol version. Enter the protocol version.
	ISSUE	0 or 1	Protocol issue. Enter the protocol issue designated for the specified logical terminal. Enter 0 for stimulus and MFT protocols, or 1 for BellCore functional protocol.
		UATEI	User-assigned terminal endpoint identifier. Enter the dynamic user-assigned terminal endpoint identifier if required.

Datafill example for table LTDEF

The following example shows sample datafill for table LTDEF.

TR-303 Generic Interface (continued)**MAP display example for table LTDEF**

LYKEY	LTAP	CLASSREF
SMA2	B	
BRAFS	(NOPMD)	(PVC FUNCTIONAL 0) \$
SMA2	B2	
BRAFS	(NOPMD)	(PVC FUNCTIONAL 2) (DTEI) (SPIDSFY 1) (EKTS) \$

Datafilling table SPECCONN

Table special connection (SPECCONN) is used to set-up special-service connections that require dedicated nailed-up connections through the DMS-100 switch. Special-service connections are set-up and maintained through software, as opposed to physical hard-wired connections. Once set-up, the connection remains, until it is removed from table SPECCONN by operating company personnel.

The following table shows the datafill specific to TR-303 Generic Interface for table SPECCONN. Only those fields that apply directly to TR-303 Generic Interface are shown.

Datafilling table SPECCONN (Sheet 1 of 4)

Field	Subfield or refinement	Entry	Explanation and action
ENDPT1		see subfield	Endpoint 1. Endpoint 1 is specified in subfield SCSEL.
	SCSEL	DS1, ISLC or DCHCHNL	Special connection selector. Enter the type of selector for endpoints.
	DCHCHNL	see subfields	DCH channel. See subfields ISGNO and CHNL.
	ISGNO	0 to 255	D-channel handler number. Enter the D-channel handler identifier.
	CHNL	0 to 31	Channel number. Enter the D-channel on the D-channel handler.
	DS1	see subfields	DS1. See subfields PMTYPE, SMANO, SMACKTNO, and SMACKTTS.
	PMTYPE	SMA2	Peripheral module type. Enter the type of PM.
	SMA2NO	0-511	SMA2 number. Enter the external number of the SMA2.

TR-303 Generic Interface (continued)**Datafilling table SPECCONN (Sheet 2 of 4)**

Field	Subfield or refinement	Entry	Explanation and action
	SMA2CKTNO	0-47	SMA2 circuit number. Enter the P-side port number on the SMA2.
	SMA2CKTTS	1 -24	SMA2 time slot. Enter the time slot (channel) on the DS-1.
	ISLC	see subfields	ISDN line card. See subfields LEN and CHANNEL.
	LEN	see subfields	Line equipment number. This field contains the following subfields: SITE, RDTFRAME, RDTUNIT, RDTSHELF, and RDTSLLOT.
	SITE	alphanumeric	Site. Enter the location of the RDT (four-character alphanumeric). This entry is not optional, and there is no default value assigned to it.
	RDT FRAME	0-511	RDT frame. Enter the RDT frame number, which is not a physical frame but a software entity that represents the group the RDT belongs to at the site.
	RDT UNIT	0-9	RDT unit. Enter the number representing the RDT unit within the group.
	RDT SHELF	0-6	RDT shelf. Enter the shelf number where the RDT resides. For GENTMC signaling, the range is from 0-6.
	RDT SLOT	1-99	RDT slot. Enter the slot number where the RDT resides.
	CHNL	B1 or B2	Channel. Enter the ISDN line card channel.
ENDPT2		see subfield	Endpoint 2. Endpoint 2 is specified in subfield SCSEL.
	SCSEL	DS1, ISLC or DCHCHNL	Special connection selector. Enter the type of selector for endpoints.
	DCHCHNL	see subfields	DCH channel. See subfields ISGNO and CHNL.
	ISGNO	0 to 255	D-channel handler number. Enter the D-channel handler identifier.

TR-303 Generic Interface (continued)

Datafilling table SPECCONN (Sheet 3 of 4)

Field	Subfield or refinement	Entry	Explanation and action
	CHNL	0 to 31	Channel number. Enter the D-channel on the D-channel handler.
	DS1	see subfields	DS1. See subfields PMTYPE, SMANO, SMACKTNO, and SMACKTTS.
	PMTYPE	SMA2	Peripheral module type. Enter the type of PM.
	SMANO	0-511	SMA2 number. Enter the external number of the SMA.
	SMACKTNO	0-53	SMA2 circuit number. Enter the P-side port number on the SMA2.
	SMACKTTS	1 -24	SMA2 time slot. Enter the time slot (channel) on the DS-1.
	ISLC	see subfields	ISDN line card. See subfields LEN and CHANNEL.
	LEN	see subfields	Line equipment number. This field contains the following subfields: SITE, RDTFRAME, RDTUNIT, RDTSHELF, and RDTSLLOT.
	SITE	alphanumeric	Site. Enter the location of the RDT (four-character alphanumeric). This entry is not optional, and there is no default value assigned to it.
	RDT FRAME	0-511	RDT frame. Enter the RDT frame number, which is not a physical frame but a software entity that represents the group the RDT belongs to at the site.
	RDT UNIT	0-9	RDT unit. Enter the number representing the RDT unit within the group.
	RDT SHELF	0-20	RDT shelf. Enter the shelf number where the RDT resides. For GENTMC signaling, the range is from 0-20, up to the maximum defined in table RDTINV, based on the size of RDT datafilled.

TR-303 Generic Interface (continued)

Datafilling table SPECCONN (Sheet 4 of 4)

Field	Subfield or refinement	Entry	Explanation and action
	RDT SLOT	1-99	RDT slot. Enter the slot number where the RDT resides. For GENTMC signaling, the range is from 0-99, up to the maximum defined in table RDTINV, based on the size of RDT datafilled.
	CHNL	B1 or B2	Channel. Enter the ISDN line card channel.
CONTYPE		CAB, CON, or PEND	Connection type. Enter CAB for A-bit and B-bit signaling connected, CON for connected, or PEND for pending.
STATUS		ACTIVE	Connection status. Enter the status of the connection.

Datafill example for table SPECCONN

The following example shows sample datafill for table SPECCONN.

MAP display example for table SPECCONN

ENDPT1	ENDPT2	CONTYPE	STATUS
DCHCHNL 1 28 DS1 SMA2 0 0 1	CON	ACTIVE	
DCHCHNL 1 29 DS1 SMA2 0 0 2	CON	ACTIVE	
ISLC RDT1 1 0 0 16 B1 DS1 SMA2 0 1 9	CON	ACTIVE	
ISLC RDT1 1 0 0 18 B2 DS1 SMA2 0 1 10	CON	ACTIVE	

Datafilling table RDTINV

The remote digital terminal inventory (RDTINV) table contains inventory data, including RDTs and their corresponding IDTs, in the DMS-100 switching office. This table also contains the C-side connectivity information and RDT configuration information.

If ISDN is provisioned, a maximum of five RDTs can be associated with one SMA2. When an RDT is added to table RDTINV, a corresponding IDT in the SMA2 is also created by DMS SuperNode switch software.

When an RDT is deleted from table RDTINV, the corresponding IDT is deleted. Table RDTINV creates an RDT as a remote to the DMS SuperNode switch and defines its attributes.

TR-303 Generic Interface (continued)

Provisioning new RDTs by size

To support a wide range of RDTs having different line capacity from different vendors, RDTs are provisioned as follows:

- For SMA2s provisioned with RDTs prior to NA006/XPM07, RDTs are categorized into three sizes: small, medium, and large. These categories impose limits on the number of RDTs that can be connected to an SMA2. The following table identifies these limits.

RDT to SMA2 limits

RDT size	Lines capacity	Number of RDTs connected to an SMA2
Small	Up to 671 lines	Up to 8 (only POTS lines) Up to 5 (POTS and ISDN lines)
Medium	Up to 1344 lines	Up to 4
Large	Up to 2048 lines	Up to 2

The first RDT on an SMA2 can be datafilled as supporting up to 671, 1344, or 2048 lines. Subsequent RDTs datafilled on the same SMA2 will be provided line capacities equal to the capacity defined by the first RDT datafilled. For SMA2s with existing RDTs, a larger size RDT can only be datafilled if all existing RDTs are deleted.

- For new SMA2s provisioned with RDTs from NA006/XPM07 on, calculating RDT size involves selecting a size between 671 and 2048 for all RDTs on the SMA2. For example, if a vendor's RDT is a 768 line device, the operating company personnel will define the first RDT on the SMA2 as size 768 and all other RDTs will also have the same size. The calculation for the maximum number of RDTs that can be connected to an SMA2 is as follows:

$$\frac{5384}{(\text{maximum lines on the vendor's RDT} + 2)} = \text{Maximum number of RDTs per SMA2}$$

For example, if a 768 line RDT is chosen, the result is 6 RDTs if they are not equipped with ISDN, or 5 if they are equipped with ISDN.

$$\frac{5384}{(768 + 2)} = \frac{5384}{770} = 6$$

TR-303 Generic Interface (continued)

Determining the size of RDTs to be datafilled on an SMA2

To determine the size of an RDT to be datafilled on a specified SMA2 access the MVSIZECI MAP directory and execute the QUERYSIZE command. The following example shows the syntax for command QUERYSIZE.

```
>QUERYSIZE sma_type sma_no
```

where:

sma_type

is an SMA or SMA2

sma_no

is a value from 1 to 255

The size of the RDT is displayed as the number of lines supported by the RDTs connected to the queried SMA or SMA2.

The following response at the MAP display indicates a successful RDT size query. The response displays the size of the RDT, the maximum number of lines supported for the RDT size, the total number of RDTs currently datafilled on the specified SMA2, and the maximum number of RDT lines for each SMA2.

```
Size of RDTs on <SMA TYPE> <SMA NO> = <SIZE>  
                                     (Max Lines/RDT = <MAXLINES>).  
Total RDTs off <SMA TYPE> <SMA NO>= <NO OF RDTs>  
                                     (Max <SIZE> RDTs = <MAXRDTs>).
```

The following error message indicates the command was unable to query the size of the RDT. If this message occurs, the subscriber should ensure the SMA2 being queried has been provisioned.

```
Unable to query SMA size.
```

RDT path protection link information

The remote digital terminal path protection link (RDTPLNK) field defines which RDT link conveys the secondary, or backup messaging (EOC and TMC) channels in the event of a primary link, (RDT link 1) failure. The range for possible entries is between 1 and 28, although the minimum valid value is 2 for RDT link number. Entering a value of 1 is rejected because 1 would attempt to make the secondary messaging channels the same as the primary, resulting in a loss of messaging redundancy.

TR-303 Generic Interface (continued)

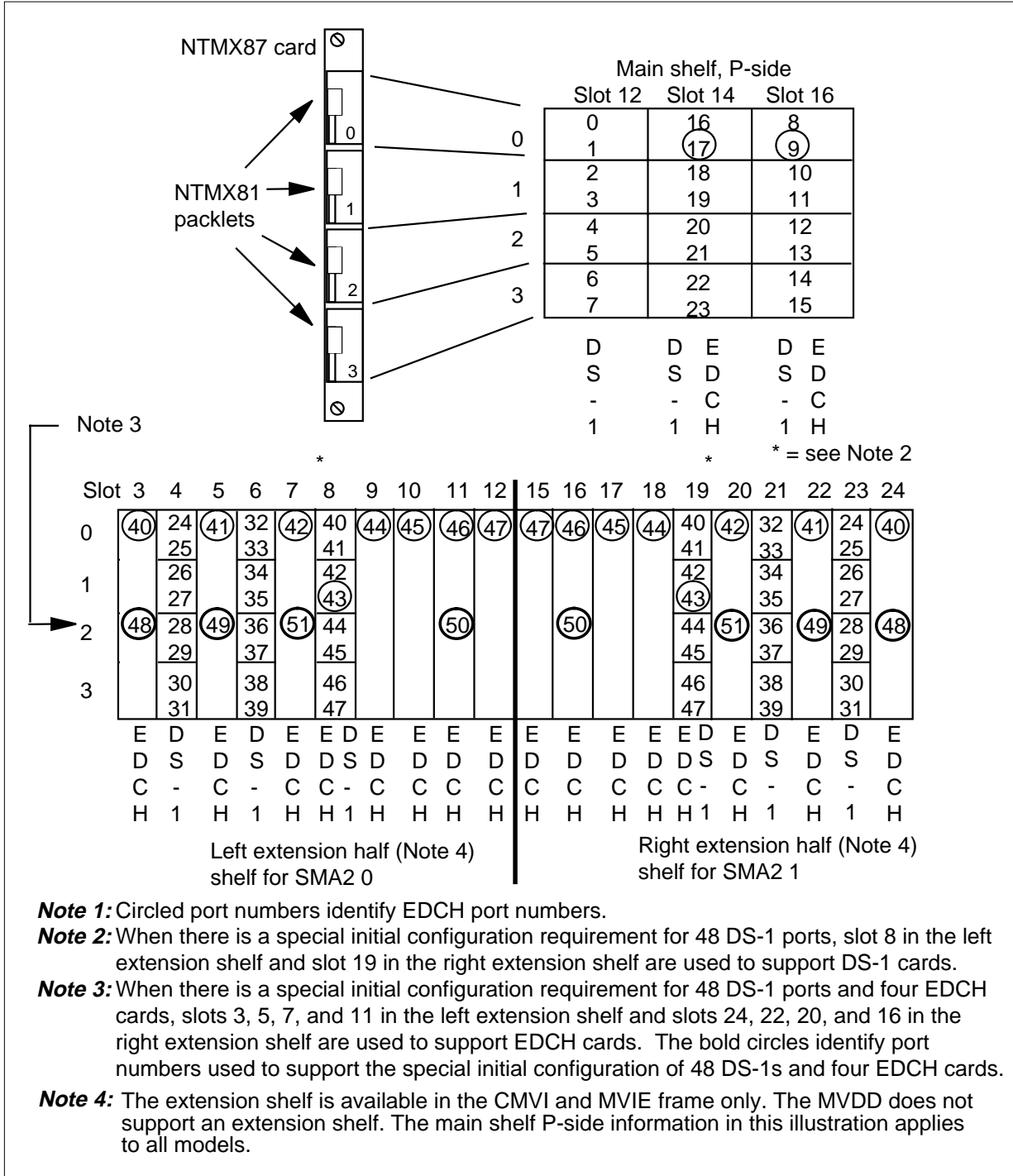
Since the minimum number of links required for an RDT is two, then the RDTPLNK value is 2. If four RDT links are defined then the valid values are 2 through 4. When in doubt, use 2. Another point that makes provisioning of this field confusing is that the SMA2 DS-1 link numbers are zero based as defined in the LTCPSINV table. If DS-1 links 4 through 7 are used for a particular RDT they become RDT links 1 through 4. Defining RDT link 3 as the RDTPLNK corresponds to SMA2 DS-1 link 6.

Note: When provisioning RDTs, it is important to consider how the DS-1 links are to be mapped to the SMA2. To ensure reliability, it is recommended that the primary and secondary messaging links are on separate NTMX81 and NTMX87 cards in the SMA2. From the RDTs point of view, ensure the primary and secondary messaging links are on separate interfaces or cards.

The following figure shows the P-side port to associated card slot numbering scheme. Use this figure to determine which DS-1 card slots and ports to choose as primary and secondary messaging link connections at the SMA2.

TR-303 Generic Interface (continued)

P-side port numbering to card slot scheme



TR-303 Generic Interface (continued)

Setting up a shared metallic bypass to support RDT line testing

Operating companies that configure RDTs to share a common metallic bypass pair for line tests, must include an inhibit lead to block access to the shared bypass pair by both RDTs at the same time. Configuring the inhibit lead requires datafill in tables RDTINV, SCGRP, and SDGRP.

To set up a shared metallic bypass in a DMS-100 central office environment, perform the following procedure:

- 1 Define SC and SD in tables SDGRP and SCGRP, as shown in the following examples:
- 2 Define scan points (SC) and scan distribution points (SD) in tables SDGRP and SCGRP, as shown in the following examples:

```
TABLE: SDGRP:
0   MTM   1       20   2X57AA
```

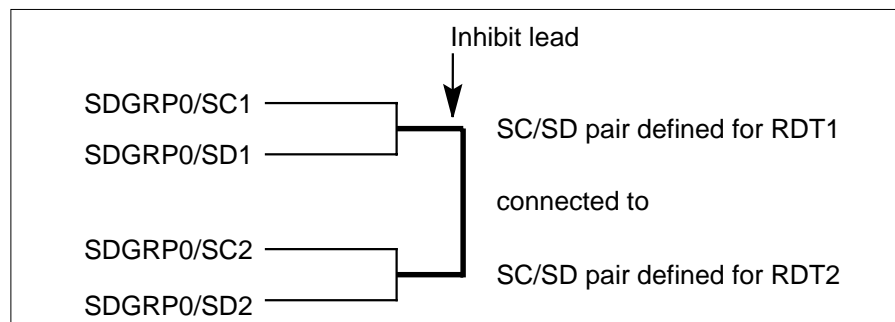
```
TABLE: SCGRP:
0   MTM   3       8   0X10AA
```

- 3 Reserve an SC and an SD point for use as an inhibit lead for an RDT by adding its group and point number in table RDTINV.

An example of the table datafill follows:

```
TABLE: RDTINV:
RDT1 101 0 101 SMA2 1 101 $ $ $ GENTMC 2 671 N Y (TBP BOTH
4 TAP1 Y 0 1 0 1) $ (1 6) (2 7) $ N STDLN S $ (NETWORK_ID
1)(NETWORKELEMENT_ID 100) $
```

- 4 Connect the defined SC and SD points together to function as an inhibit lead, as shown in the following example:



Engineering LAPD parameters

The LAPD flow control mechanism is used for EOCs and the TMC. LAPD flow control consists of a sliding window K, that limits the number of outstanding frames at one time, and the receiver-not-ready (RNR) message that may be sent from one peer to the other to indicate the sender is currently unable to accept incoming data.

The EOC transmits provisioning and line maintenance messages to the RDT. For TR-303 the TMC is used for call establishment and take down.

TR-303 Generic Interface (continued)

Table RDTINV contains one tuple per RDT. Two additional sets of default values for the LAPD parameter are needed for a TR-303 RDT. One is for the TMC, and one is for the TR-303 EOC. These values are used if the RDT datafilled has a VARTYPE of GENTMC.

When values are entered for the LAPD parameters, table control enforces a valid range of values.

Note: The SMA2 has been designed to operate at optimum efficiency with the LAPD parameters set to their default values. It is best to leave the default values in place unless a specific reason exists for changing one of these parameters.

Should it be necessary to alter the LAPD parameters, the two parameters on both ends (RDT and DMS) should be changed together. Use the guidelines given in the following table.

MVI LAPD parameter values

Parameter	MVI range	Default MVI	Step size
Maximum number of unacknowledged frames (K)	1-7	7	1
Maximum number of retransmissions (N200)	1-10	3	1
Maximum number of octets in one frame (N201)	TMC=1-32 EOC=1-256	TMC=32 EOC=256	NA
Maximum time to wait for acknowledgement for one frame (T200)	100-350 ms	150 ms	50 ms
Period of inactivity on data link (T203)	10 s-300s	30 s	10 s

TR-303 Generic Interface (continued)

The following table shows the datafill specific to TR-303 Generic Interface for table RDTINV. Only those fields that apply directly to TR-303 Generic Interface are shown.

Datafilling table RDTINV (Sheet 1 of 11)

Field	Subfield or refinement	Entry	Explanation and action
RDTNAME		see subfields	RDT name. This is the key to this table, it is used to uniquely identify the RDT to the system. This field contains subfields SITE, FRAME, and UNIT.
	SITE	alphanumeric	Site. Enter the four-character site name assigned to the remote location. This entry should also appear in table SITE.
	FRAME	0-511	Frame. Enter the logical frame number.
	UNIT	0-9	Unit. Enter the logical unit number. Note: The unit number should be 0 for the IDT configured with EOC. When the RDTINV field EOC is datafilled as S or O, the UNIT number datafilled in this field should be 0.
ADNUM		0-4095	Administration number. This number is used by the Engineering and Administrative Data Acquisition System for Data Collection (EADAS/DC) to identify nodes within the DMS-100 Family switch, It remains fixed over dump and restore.

TR-303 Generic Interface (continued)

Datafilling table RDTINV (Sheet 2 of 11)

Field	Subfield or refinement	Entry	Explanation and action
IDTNAME		see subfields	<p>IDT name. This field identifies the SMA2 and the IDT the RDT where it is connected to. It contains subfields XPMTYPE, XPMNO, and IDTNO.</p> <p>Note 1: The IDT must be offline to change this field.</p> <p>Note 2: When an attempt is made to move an IDT from one SMA2 to another SMA2, and the SMA2 is in an overload condition, the following warning message is displayed. This message informs that static data may require a manual update after the IDT is moved, if the dynamic static data update fails.</p> <p>Warning: SMA2 <sma2_no> is in overload. Static data update may fail.</p> <p>Note: If the dynamic static data update fails, the following warning message is displayed:</p> <p>Warning: Additional Static data not updated for SMA2 <sma2_no> Unit <unit_no>.</p> <p>Note: If the dynamic static data update is successful, the following message is displayed:</p> <p>Warning: Additional Static data updates completed for SMA2.</p>
	XPMTYPE	SMA2	XMS-based peripheral module type. This field identifies the type of peripheral where the RDT is connected.
	XPMNO	0-127	XPM number. This identifies the SMA2 where the RDT is connected.
	IDTNO	0-255	IDT number. This identifies the IDT where the RDT is connected.
			<p>Note: The IDT cannot be deleted if there are lines attached to it.</p>

TR-303 Generic Interface (continued)

Datafilling table RDTINV (Sheet 3 of 11)

Field	Subfield or refinement	Entry	Explanation and action
NENAME		\$	Source identifier. This is used by the external operation support system to identify the RDT. The range is 1 to 20 characters.
PRIMOPC		1-20 characters	Primary OPC identifier. This field is datafilled with a \$ to satisfy the table editor.
BACKOPC		1-20 characters	Backup OPC identifier. This field is datafilled with a \$ to satisfy the table editor.
VARTYPE		see subfield	Variant type. Indicates the type of integrated digital loop carrier. Field VARTYPE contains subfield RDTVVAR.
	RDTVVAR	GENTMC	RDT variable. Enter GENTMC for an RDT equipped with generic TR-303 TMC signaling. For the MVI application, GENTMC is supported. Datafill subfields RDTPLNK, MAXLINES, and INHLINE. Note: RDTVVAR cannot be changed. The tuple must be deleted and added again.

TR-303 Generic Interface (continued)

Datafilling table RDTINV (Sheet 4 of 11)

Field	Subfield or refinement	Entry	Explanation and action
	RDTPPLNK	1-28	<p>RDT path protection link. This field represents the path protection DS-1. This DS-1 represents the link number applied by the RDT, and must appear as an RDTLINK value in the LINKMAP vector. This value must not be equal to RDT DS-1 number 1.</p> <p>Note: Though the range of possible entries is between 1 and 28, the actual minimum valid entry is 2. Entering a value of 1 will be rejected because entering 1 will render the secondary messaging channel the same as the primary, thereby resulting in a loss of messaging redundancy.</p> <p>Since the minimum number of links required for an RDT is 2, the RDTPPLINK value is 2. If four RDT links are defined, then the valid values are 2 through 4, but when in doubt, use a value of two.</p> <p>Note: DS-1 link numbers are zero based as defined in table LTCPSINV. If DS-1 links 4 through 7 are used for a particular RDT they become RDT links 1 through 4. If RDT link 3 is defined as the RDTPPLINK value, then that corresponds to SMA2 DS-1 link 6.</p>

TR-303 Generic Interface (continued)**Datafilling table RDTINV (Sheet 5 of 11)**

Field	Subfield or refinement	Entry	Explanation and action
	MAXLINES	1-2048	<p>Maximum number of lines. Indicates the maximum number of lines a multi-vendor RDT supports. The SMA2 supports up to 2048 lines for each RDT.</p> <p>For SMA2s provisioned with RDTs prior to NA006/XPM07, RDTs are categorized into three sizes: small, medium, and large. These categories impose limits on the number of RDTs that can be connected to an SMA2. Values for the first RDT datafilled on an SMA2 are 1-671 defaults to 671, 672-1344 defaults to 1344, and 1345-2048 defaults to 2048. Any value greater than 2048 results in an error message.</p> <p>Values for subsequent RDTs datafilled on a specific SMA2 will be written to the MAXLINES value of the first RDT datafilled. Any value greater than MAXLINES defined for the first RDT datafilled will result in an error message.</p> <p>For new SMA2s provisioned with RDTs from NA006/XPM07 on, calculating RDT size involves selecting a size between 671 and 2048 for all RDTs on the SMA2. For example, if a vendor's RDT is a 768 line device, the operating company personnel will define the first RDT on the SMA2 as size 768 and all other RDTs will also have the same size.</p>
	INHLINE	Y or N	<p>Inherent lines. Indicates if the MVI RDT supports the creation of analog line instances and access side of ISDN line instances by entities other than the DMS SuperNode switch. Entry values are yes (Y) and no (N). If Y is entered, another entity creates the analog and access side of line instances at the RDT. If N is entered, line instances are created by the DMS SuperNode switch.</p>
CLAPDFLT		Y or N	<p>Choose LAPD default. Specifies for the IDT whether default or optional LAPD parameters are to be used. Enter Y (use default parameters) or N (need to define the optional parameters). If N is datafilled, subfield CLAPDPAR appears.</p>

TR-303 Generic Interface (continued)

Datafilling table RDTINV (Sheet 6 of 11)

Field	Subfield or refinement	Entry	Explanation and action
	CLAPDPAR	alphanumeric	Choose LAPD parameters. Specifies the nondefault LAPD parameters. Enter the selected link access procedure and complete the refinements identified in the following: <ul style="list-style-type: none"> • N201 and a number from 1-256 • N200 and a number from 1-10 • K and a number from 1-7 • T203 and a number from 10-300 s • T200 and a number from 100-350 ms
MTSTACPT		see subfield	Metallic test access point. This is the selector field that identifies types of metallic test access (MTA) points, configured on the RDT.
	TSTUTTYP	TBP, ERTU, or \$	The selector field includes <ul style="list-style-type: none"> • TBP (test bypass pair) • ERTU (external remote test unit) • \$ (used for no entry, or stopping)
TBP		see subfields	Test bypass pair. This selector identifies the MTA point configured to supply metallic test bypass for MTM-based test heads, or NTT access that requires a horizontal cross-connect at the MTA, the trunk circuit for the metallic line test equipment. This field contains subfields TSTHDUSR, VERTID, and TSTACCPA.
	TSTHDUSR	MAPIF, NTTIF or BOTH	Test head user. This field is used to tell which test system (MAP, NTT or BOTH) uses the test head.
	VERTID	0-1023	Vertical identifier. This field replaces the VERTID section of the original prompt (PT_CONNECTION_INFO). This represents the vertical in the MTA matrix where the control path is tied.

TR-303 Generic Interface (continued)

Datafilling table RDTINV (Sheet 7 of 11)

Field	Subfield or refinement	Entry	Explanation and action
ERTU	TSTACCPA	TAP1	Test access path. This field replaces the MTAUID and MTAPTID section of the original prompt PT_CONNECTION_INFO. TAP1 is the required entry with a generic TR-303 RDT.
	SCSDUSED	Y or N	Scan point/signal distributor point used. Enter Y if SD/SD points are used and provide the multiple containing: <ul style="list-style-type: none"> • INHSCGRP—range of 0-511 • INHSCPT—range of 0-6 • INHSDGRP—range of 0-511 • INHSDPT—range of 0-6 Otherwise, enter N.
		see subfields	External remote test unit. This selector identifies an external metallic test head on the RDT for NTT testing. This selector is compatible with the TBP selector, which is used for MAP terminal testing. This field contains subfields VERTID and TSTACCPA.
	VERTID	0-1023	Vertical identifier. This field replaces the VERTID section of the original prompt (PT_CONNECTION_INFO). This represents the vertical in the MTA matrix where the control path is tied.
	TSTACCPA	TAP1	Test access path. This field replaces the MTAUID and MTAPTID section of the original prompt PT_CONNECTION_INFO. ERTU can be connected to TAP 1.

TR-303 Generic Interface (continued)

Datafilling table RDTINV (Sheet 8 of 11)

Field	Subfield or refinement	Entry	Explanation and action
	SCSDUSED	Y or N	<p>Scan point/signal distributor point used. Enter Y if SD/SD points are used and provide the multiple containing:</p> <ul style="list-style-type: none"> • INHSCGRP range of 0-511 • INHSCPT range of 0-6 • INHSDGRP range of 0-511 • INHSDPT range of 0-6 <p>Otherwise, enter N.</p>
LINKTAB		numeric	<p>Link table. This is a vector, with up to 28 entries, that defines the mapping of the C-side links of the RDT (logical link) (RDTLINK is a value from 1 to 28), to the P-side links (physical link) (XPMLINK is a value from 0 to 47) of the SMA2.</p> <p>Note 1: When datafilling field C-side link table (LNKTAB), ensure message links are not assigned to the same physical interface card. When the interface card supports two or more links, separate the message links by the number of links on the interface cards. If an attempt is made to assign message links on the same interface card, table control issues a warning. Assigning message links to the same interface card can cause an E1 outage (failure of all message links) if the card fails.</p> <p>Note 2: When attempting to change an existing message link, the following error message is displayed and the change is blocked. This only happens during a tuple update operation.</p> <p>Error: XPM message link <link_no> cannot be changed to a speech link where link_no is a value from 0 to 47</p>
PROT		N	<p>Facility protection switching. Specifies whether protection switching is supported.</p>
POTSPADG		STDLN	<p>POTS pad group. The acceptable values are UNBAL and STDLN. Enter STDLN as a value.</p>

TR-303 Generic Interface (continued)**Datafilling table RDTINV (Sheet 9 of 11)**

Field	Subfield or refinement	Entry	Explanation and action
EOC		see subfields	<p>Embedded operations channel. Indicates whether EOC is present, and whether standard or LAPD parameters are used. This field contains subfields EOCTYPE and ELAPDPAR.</p> <p>Note: The IDT and the channel must be offline to be changed.</p>
	EOCTYPE	S or O	<p>EOC type. Indicates whether the EOC uses standard or optional LAPD parameters. Enter</p> <ul style="list-style-type: none"> • S for standard LAPD parameters • O for optional LAPD parameters. The subfield ELAPDPAR will appear. <p>Note: The LAPD parameters of the EOC/TMC can be changed when the IDT and the channel are man-busied or offline. When an RDT is datafilled with S or O, the value of the UNIT in RDTNAME should be 0.</p>
	ELAPDPAR	alphanumeric	<p>EOC LAPD parameters. Appears when O is entered in the EOCTYPE subfield. Specify the optional LAPD parameters. Enter five values, with a space between each value.</p> <ul style="list-style-type: none"> • Enter N201 and 256 ms • Enter N200 and a number from 1-10 • Enter K and a number from 1-7 • Enter T203 and a number from 10 s-300 s • Enter T200 and a number from 1 ms-1023 ms

TR-303 Generic Interface (continued)

Datafilling table RDTINV (Sheet 10 of 11)

Field	Subfield or refinement	Entry	Explanation and action
SDPOINTS		alphanumeric	<p>Signal distribution points. Enter the signal distribution point that corresponds to this RDT.</p> <p>If there are which-RDT SD points that are operated when the RDT enters an alarm, the range of values are:</p> <ul style="list-style-type: none"> • RDTSD1 • RDTSD2 • RDTSD3 • RDTSD4 • RDTSD5 • RDTSD6 • RDTSD7 • RDTSD8 <p>There is a maximum of 255 different combinations of activated SD points to indicate the RDT is raising an alarm. This field can be used to group RDTs, by assigning the same "which RDT" points to multiple RDTs.</p> <p>Each SD point must first be datafilled in table ALMSD. The IDT must be offline to change the SD point.</p> <p>Note: If this field is set to \$ (nil), indicating no SD point for an RDT's alarm is datafilled, the SD points that indicate alarm severity, RDTCRIT, RDTMAJOR, RDTMINOR, are not activated.</p>
RDTDN		see subfields	<p>RDT distinguished name. This is a vector of one to five elements for the RDT_RDN, with each element representing a relative distinguished name (RDN) that makes up the distinguished name of the RDT. This field is datafilled when an RDT tuple is being added. If an attempt to modify this field occurs, an error message is received.</p>

TR-303 Generic Interface (continued)**Datafilling table RDTINV (Sheet 11 of 11)**

Field	Subfield or refinement	Entry	Explanation and action
	RDN_TYPE		Relative distinguished name. Enter the RDN of the RDT. The range of values is as follows: <ul style="list-style-type: none"> • NETWORK_ID • NETWORKELEMENT_ID If field VARTYPE is set to GENTMC, only NETWORK_ID and NETWORKELEMENT_ID need to be specified. For an RDT, the network_id value must be set to 1.
	RDN_VAL	0-32767	Relative distinguished name value. Enter the value for the RDN.

Datafill example for table RDTINV

The following example shows sample datafill for table RDTINV.

MAP display example for table RDTINV

RDTNAME	ADNUM	IDTNAME	NENAME	VARTYPE
	PRIMOPC		BACKOPC	MTSTACPT
	PROT	POSTPADG	EOC	LINKTAB
				SDPOINTS
				RDTDN
RDT1	03 2	10	SMA2 1 3	\$
		\$		\$
			GENTMC	2 2048 Y Y
			(1 3) (2 5) (4 6) (7 8)	\$
N	STDLN		S	\$
		(NETWORK_ID 1)	(NETWORKELEMENT_ID 22)	\$

TR-303 Generic Interface (continued)

Error messages for table RDTINV

The following error messages apply to table RDTINV.

Error messages for table RDTINV (Sheet 1 of 2)

Error message	Explanation and action
TR303 RDT CARY 2 0 does not support the drawer option.	The POST command with the drawer option is disabled for MVI RDT lines.
TR303 LAPD parameter T200 for the EOC is out of range.	The range of parameter T200 is smaller in the TR-303, than the RDT. The RDT range for parameter T200 is implemented in table control.
RDT LAPD parameter T203 for the EOC is out of range.	The range of parameter T203 is larger in the TR-303 than the RDT. The TR-303 range for parameter T203 is implemented in table control.
Error: Cannot delete this IDT until all lines are deleted at the RDT. Return to service EOC and allow delete requests to be processed. Monitor table RDTLT for the status of these lines.	All lines associated with the IDT are deleted from table LNINV. All delete request confirmations have <i>not</i> been received and processed prior to the deletion of the IDT from table RDTINV.
Error: Primary messaging DS1 link not configured.	The LINKMAP vector has no elements datafilled.
Error: RDTPLNK field may not be changed.	The path protection DS-1 cannot be changed. It has been set as message capable. The tuple must be deleted and re-added.
Error: Secondary message DS1 is not in use.	A LINKMAP element is not datafilled with a RDTLINK value corresponding to the defined RDTPLNK value.
Error: Cannot have more than 8 RDTs on this SMA2.	An attempt is made to datafill one more RDT on an SMA2 that is allowed based on the maximum RDT calculation presented at the beginning of the section on datafilling table RDTINV.
Error: Cannot add this RDT. Only 255 RDTs can be datafilled per office.	An attempt is made to datafill an RDT when table RDTINV already has 255 RDTs datafilled in it.

TR-303 Generic Interface (continued)

Error messages for table RDTINV (Sheet 2 of 2)

Error message	Explanation and action
Error: Only RDTs of 724 lines are allowed on this host peripheral.	An attempt is made to datafill an RDT that is larger or smaller than the first RDT datafilled on the SMA2 as 724 (for example). Note: This error also occurs if you attempt to move a RDT from one SMA or SMA2 to another SMA or SMA2 with a different size RDT datafilled.
Error: Cannot have more than 5 RDTs with a DCH present.	An attempt is made to datafill more than five RDTs on an SMA2 supporting EDCHs.

Datafilling table TMINV

The trunk module inventory (TMINV) table contains hardware and software information for each trunk module provisioned in an office. This table is important for the SMA2-RDT system because it identifies the trunk modules or MTMs that contain test circuits that terminate test pairs connected to RDT lines.

The following table shows the datafill specific to TR-303 Generic Interface for table TMINV. Only those fields that apply directly to TR-303 Generic Interface are shown.

Datafilling table TMINV (Sheet 1 of 3)

Field	Subfield or refinement	Entry	Explanation and action
TMNM		see subfields	Trunk module number. This field contains subfields TMTYPE and TMNO.
	TMTYPE	TM8, MTM, or OAU	Trunk module type. Enter the trunk module type.
	TMNO	numeric	Trunk module number. Enter the trunk module number. Range for TM8 is 0-2047. The range for maintenance trunk module (MTM) is 0-255. For an office alarm unit (OAU), enter 0.
FRTYPE		TME	Frame type. Enter the frame type where the trunk module is located. Enter TME.

TR-303 Generic Interface (continued)**Datafilling table TMINV (Sheet 2 of 3)**

Field	Subfield or refinement	Entry	Explanation and action
FRNO		0-511	Frame number. Enter the frame number of the TME frame.
SHPOS		numeric	Shelf position. Enter the base mounting position of the trunk module. For TM8, range is 04, 18, 32, 51, or 65. For an MTM, enter 65. For an OAU, enter 51.
FLOOR		0-99	Floor. Enter the floor number where the trunk module is located.
ROW		alphabetic	Row. Enter the row number where the trunk module is located. The range is A-H, J-N, P-Z, AA-HH, JJ-NN, and PP-ZZ.
FRPOS		numeric	Frame position. Enter the bay position of the TME frame.
LKDATA		see subfields	C-side link data. For switches equipped with the JNET, this field contains subfields NMPAIR and NMPORT. For switches equipped with the ENET, this field contains subfields ENSHELF, ENSLOT, ENLINK, and ENDS30.
	NMPAIR	0-31	Network module pair number. Enter the network module number assigned to the trunk module.
	NMPORT	0-63	Network port number. Enter the network module port number assigned to the trunk module.
	ENSHELF	0-7	ENET shelf number. Enter the shelf number where the PM is assigned.
	ENSLOT	10 to 16, 25 to 32, or 13 to 19	ENET slot number. Enter the crosspoint slot number where the PM is assigned. Enter a value between 10 and 16 or 25 and 32. For a DMS SuperNode SE switching unit, enter a value between 13 and 19.
	ENLINK	0-15	ENET link number. Enter the link on the crosspoint where the PM is assigned.

TR-303 Generic Interface (continued)**Datafilling table TMINV (Sheet 3 of 3)**

Field	Subfield or refinement	Entry	Explanation and action
	ENDS30	0 to 15	ENET DS30 Enter a value from 0 (zero) to 15 for fiber links. This field defaults to 0 (zero) if the link is a DS-30. All entries must be contiguous from 0 (zero). No entry can be duplicated.
EQPEC		alphanumeric	Equipment product engineering code (PEC). Enter the PEC of the trunk module.
LOAD		alphanumeric	Load. Enter the issue name of the PM software.
EXECS		alphanumeric	Executive programs. Enter the set of executive programs required for the trunk module.

Datafill example for table TMINV

The following example shows sample datafill for table TMINV.

MAP display example for table TMINV

```

TMNM FRTYPE FRNO SHPOS FLOOR ROW FRPOS LKDATA EQPEC
LOAD
EXECS          SCTMLOC
-----
TM8 0  TME    1   65      0   L   16   0 53 2X52AG
BTMKA02
TM8EX                N

```

Datafilling table TRKGRP

Table trunk group (TRKGRP) contains customer defined data associated with each trunk group existing in the switching unit. Each trunk group entry in table TRKGRP consists of a unique CLI for the trunk group, and a number of other fields determined by the trunk group type (field GRPTYP). The trunk group types that apply to the SMA2-RDT system are MAINT for maintenance trunks such as MTU, and TD for no test trunks such as BASIC or MLT trunks. Table TRKGRP identifies test circuits associated with maintenance and test trunks.

SCM line monitor access

When operating company personnel at a remote test center initiate testing on a subscriber line, the line is sometimes in a call processing busy state. Subfield BARGE in table TRKGRP determines if the line can be accessed while in the bridged mode through a conference card, thereby allowing operating company

TR-303 Generic Interface (continued)

personnel to verify the line is busy, and to not give a faulty busy signal using a no test trunk only. When the subfield is set to Y, the line can be accessed through a conference card. When the subfield is set to N, which is the default value, the line cannot be accessed through a conference card.

Because of the numerous configurations of table TRKGRP, no datafill procedure is provided for this table.

Datafill example for table TRKGRP

The following example shows sample datafill for table TRKGRP.

MAP display example for table TRKGRP

GRPKEY		GRPINFO			
HSET					
	MAINT	0	NPDGP	NCRT	5X30AA
TERM101					
	MAINT	0	NPDGP	NCRT	5X30AA
JACK					
	MAINT	0	NPDGP	NCRT	1X54AA
LTU					
	MAINT	0	NPDGP	NCRT	2X11AA
MTU					
	MAINT	0	NPDGP	NCRT	2X90AD

Datafilling table TRKSGRP

Table trunk subgroup (TRKSGRP) lists supplementary information for each subgroup assigned to one of the trunk groups listed in table TRKGRP.

Input data must be specified for at least one subgroup, or a maximum of two subgroups for each trunk group listed in table TRKGRP, excluding trunk groups defined as maintenance group types.

Note: The trunk subgroup data for maintenance and test trunks, excluding subgroup one of trunk group with code TTU, is automatically produced by table TRKGRP datafill.

Because of the numerous configurations of table TRKSGRP, no datafill procedure is provided for this table.

Datafill example for table TRKSGRP

The following example shows sample datafill for table TRKSGRP.

TR-303 Generic Interface (continued)**MAP display example for table TRKSGRP**

SGRPKEY		CARDCODE				SGRPVAR						
MTU	0	2X11BA										
STD	OG	NP	WK	0	0	NO	NO	F	N	N	17	UNEQ
MONTALK	0	2X90AD										
STD	OG	NP	WK	0	0	NO	NO	F	N	N	17	UNEQ
TTU	0	2X47AC										
STD	OG	NP	WK	0	0	NO	NO	F	N	N	17	UNEQ

Datafilling table TRKMEM

Table trunk member (TRKMEM) lists data associated with each trunk assigned to one of the trunk groups and trunk subgroups specified in tables TRKGRP and TRKSGRP. Table TRKMEM identifies the circuits associated with test equipment and trunks datafilled in tables TRKGRP and TRKSGRP.

No datafill procedure is provided for this table.

Datafill example for table TRKMEM

The following example shows sample datafill for table TRKMEM.

MAP display example for table TRKMEM

CLLI	EXTRKNM	SGRP	MEMVAR		
MTU	0	0	MTM	0	22
MTU	1	0	MTM	2	2
HSET	0	0	TM8	0	4

Datafilling table SFWALARM

Table software alarm (SFWALARM) associates a software alarm with SD points that should be activated whenever that software alarm is activated. Entries in this table cannot be added or deleted, but the data can be changed by operating company personnel.

TR-303 Generic Interface (continued)

The following table shows the datafill specific to TR-303 Generic Interface for table SFWALARM. Only those fields that apply directly to TR-303 Generic Interface are shown.

Datafilling table SFWALARM

Field	Subfield or refinement	Entry	Explanation and action
FUNCTION		alphanumeric	Function. Enter the system alarm function, up to 16 characters. RDTWRN is automatically added by the system.
REPORT		Y or N	Report. Enter Y if an alarm report is logged, otherwise enter N. For RDTWRN, this value should be set to N.
ALM		CR, MJ, MN, or NA	Alarm. Enter the type of alarm activated or NA for not applicable. For RDTWRN this value should be set to NA.
LOGIC		see subfields	Logic. This field consists of subfields SDFUNCT, ALMGRP and ALMXFR.
	SDFUNCT	alphanumeric	Signal distributor function. Enter the signal distributor function(s) associated with a specific system alarm. For RDTWRN, this value should be RDTWARN.
	ALMGRP	Y or N	Alarm grouping. Enter Y if the alarm function is implemented when the alarm grouping key is activated, otherwise enter N. For RDTWRN, this value should be N.
	ALMXFR	Y or N	Alarm transfer. Enter Y if the alarm function is implemented when the alarm transfer key is activated, otherwise enter N. For RDTWRN, this value should be N.
	CONTMARK	+ or \$	Continuation mark. Enter a (+) sign to indicate the line continues, or a (\$) to indicate the end of the line.

Datafill example for table SFWALARM

The following example shows sample datafill for table SFWALARM.

TR-303 Generic Interface (continued)**MAP display example for table SFWALARM**

FUNCTION				LOGIC
REPORT	ALM			
RDTCRT				
N	CR	(RDTCRIT	N N)	\$
RDTMJ				
N	MJ	(RDTMAJOR	N N)	\$
RDTMN				
N	MN	(RDTMINOR	N N)	\$
RDTWRN				
N	NA	(RDTWARN	N N)	\$

Datafilling table LINEATTR

Line attributes datafilled in table line attribute (LINEATTR) are assigned to regular lines in table LENLINES, and to Meridian stations and attendant consoles in MDC translation tables.

The following table shows the datafill specific to TR-303 Generic Interface for table LINEATTR. Only those fields that apply directly to TR-303 Generic Interface are shown.

Datafilling table LINEATTR (Sheet 1 of 4)

Field	Subfield or refinement	Entry	Explanation and action
LNATTIDX		0-1023	Line attribute index. Enter the index into the table.
LCC		alphanumeric	Line class code. Enter the line class code assigned to the line attribute index number. If there is no line class code, enter NLCC.
CHGCLSS		alphanumeric	Charge class. Enter the charge class for switching units configured with Local Automatic Message Accounting (LAMA). Otherwise, enter NONE.
COST		HI, LO, or NT	Class of service tone. Enter the class of service tone required.
SCRNCL		alphanumeric or NSCR	Class-of-service screening subtable name. Enter the four-character class of service assigned in the line attribute index, or NSCR if screening by class is not required.

TR-303 Generic Interface (continued)**Datafilling table LINEATTR (Sheet 2 of 4)**

Field	Subfield or refinement	Entry	Explanation and action
LTG		0-255	Line treatment group. Enter the line treatment group number assigned to the line attribute index.
STS		numeric	Serving translation scheme. Enter the three-digit serving numbering plan area (NPA) assigned to the line attribute index.
PRTNM		alphanumeric or NPRT	Standard pretranslator subtable name. Enter the four-character pretranslator subtable name assigned to the line attribute index, or NPRT if standard pretranslation is not required.
LCANAME		alphanumeric or NLCA	Local calling area screening subtable name. Enter the five-character local calling area screening subtable name assigned to the line attribute index, or NLCA if screening is not required.
ZEROMPOS		alphanumeric or NONE	Zero minus position. Enter the ten-character position given in table POSITION where operator zero minus calls are routed, or enter NONE if there are no operator zero minus calls.
TRAFSNO		0-127	Traffic separation number. Enter the network module number assigned to the trunk module.
CONTMARK		+	Continuation mark. Enter a plus sign (+) to indicate that additional information for the tuple is contained in the next record.
MRSA		alphanumeric or NIL	Message rate service area. Enter the eight-character message rate service area name found in table MRSANAME field MRSA, or enter NIL if multi-unit message rate services are not required.
SFC		alphanumeric or NILSFC	International subscriber feature class. Enter a six-character international subscriber feature class name found in table FEATCHG, or enter NILSFC if international classes are not required.
LATANM		alphanumeric	Local access and transport area name. Enter the eight-character local access and transport area name assigned to the line attribute index.

TR-303 Generic Interface (continued)**Datafilling table LINEATTR (Sheet 3 of 4)**

Field	Subfield or refinement	Entry	Explanation and action
MDI		0	Metering data index. Enter the metering data index number assigned to the line attribute index, or enter 0 if international metering data is not required.
IXNAME		see subfields	International translation system start. Consists of subfields XLASYS and XLANAME.
	XLASYS	AC, AM, CT, DT, FA, FT, OFC, NSC, PX, or NIL	International translation system. Enter the head table name where translation starts, or NIL if the switching unit does not have an international load.
	XLANAME	alphanumeric or NIL	International translation name. Enter the eight-character index referenced by field XLASYS, or enter a blank if subfield XLASYS is datafilled as NIL.
DGCL- NAME		alphanumeric or NIL	Digital analysis tables entry point. Enter an eight-character digital analysis name that appears in universal digit analysis tables DGHEAD and DGCODE, or enter NIL if the switching unit does not have an international load.
FANIDIGS		two digit code: (N, 0, 1-9, B,C,D,E,F)	Flexible ANI information digit pairs. Enter the flexible automatic number identification information digit pair assigned to the line attribute index, or enter 00 if the switching unit is not equipped with feature BR0713.
CONTMARK		+	Continuation mark. Enter a plus sign (+) to indicate that additional information for the tuple is contained in the next record.
RESINF		see subfields	Residential enhanced services information. Consists of subfields RESINFO, CUSTGRP, SUBGRP, and NCOS.
	RESINFO	Y or N	Residential enhanced services information. Enter Y if the line attribute index is required to support residential (RES) lines, or enter N if it is not.

TR-303 Generic Interface (continued)**Datafilling table LINEATTR (Sheet 4 of 4)**

Field	Subfield or refinement	Entry	Explanation and action	
OPTIONS	CUSTGRP	alphanumeric	Customer group. Enter a 16-character group name assigned to the line attribute index that appears in table CUSTENG.	
	SUBGRP	0-7	Customer subgroup. Enter the subgroup within the customer group associated with the line attribute index.	
	NCOS	0-255	Network class of service number. Enter the network class of service number within the customer group, associated with the line attribute index. The network class of service number also appears in table NCOS.	
		AMAGRPID, HOT, LDSV, or LCABILL	Line attribute options. This field is a vector consisting of four options. Enter AMAGRPID if a group identity for a subscription basis tariff is required. Enter HOT if identification of hotel lines to a traffic operator position system is required, or if the outgoing trunk group is OP. Enter LDSV is long distance signal (LDS) or long distance alerting (LDA) is required, and datafill subfield STATUS. Enter LCABILL if a noninterexchange carrier call is billable.	
		AMAGRPID	alphanumeric	Automatic message accounting group identifier. Enter the eight character group identifier that appears in table AMAGRPID.
		STATUS	ACT or DEACT	Long Distance Signal Valid status. Enter ACT to indicate that long distance signal (LDS) or long distance alerting (LDA) is activated for the line group. Otherwise, enter DEACT.
	CONTMARK		\$	Continuation mark. Enter the dollar sign (\$) to indicate the end of the tuple.

Datafill example for table LINEATTR

The following example shows sample datafill for table LINEATTR.

TR-303 Generic Interface (continued)

MAP display example for table LINEATTR

```

LNATTIDX LCC CHGCLSS COST SCRNL LTG STS PRTNM LCANAME
ZEROMPOS TRAFSNO
MRSA SFC LATANM MDI IXNAME OGCLNAME FANIDIGS RESINF
OPTIONS
-----
0 1FR NONE NT NSCR 0 919 POTS LCA0 CTOP 20
NIL NILSFC NILLATA 0 NIL NIL 00 N $

```

Datafilling table LNINV

Subscriber lines connecting to the RDT are datafilled in table line inventory (LNINV). This table defines the line equipment number (LEN) of a line and its hardware characteristics.

Mapping fields SHELF and SLOT to the line number

When the RDT is datafilled in table RDTINV, the maximum value for SHELF in table LNINV is based on the number of lines the RDT supports. The SHELF range is 0 to 20 up to the maximum defined in table RDTINV, based on the size of RDT datafilled.

Note: Operating company personnel should view the combinations of fields SHELF (also known as RDTLSG) and SLOT (also known as RDTCKT) as the the call reference value (CRV) or virtual LENS, which is a logical number equal to the line circuit. For example, if field SHELF is entered as 3, and field SLOT is entered as 4, the MVI RDT LEN represents a CRV of 304. The two fields combined can take a value of 1-2048 where RDT SHELF represents the thousands and hundreds columns (the 20 of 2048) and RDT SLOT represent the tens and units columns (the 48 of 2048).

The values of SHELF (RDTLSG) and SLOT (RDTCKT) are dependent on the values datafilled in table RDTINV. For an RDT having 672 lines, the value for SHELF is 6. The value for SLOT has a range of 0 to 99 for lines 99 to 599, with a maximum being 72 up to line 672.

The SITE, FRAME, and UNIT numbers form a line module (LM) number. The SHELF and SLOT numbers are mapped to a terminal number. Table control is provided through table RDTINV.

How the maximum number of lines is controlled

The maximum number of lines for the RDT is 2048. Field SHEFLSLT is used for the RFT variant only. If using the GENCS or GENTMC variants, field MAXLINES in table RDTINV is used to limit the number of lines an RDT can support.

TR-303 Generic Interface (continued)

The following table shows datafill specific to TR-303 Generic Interface for table LNINV. Only those fields that apply directly to TR-303 Generic Interface are shown.

Datafilling table LNINV (Sheet 1 of 2)

Field	Subfield or refinement	Entry	Explanation and action
LEN		see subfields	Line equipment number. This field contains the following subfields: SITE, RDTFRAME, RDTUNIT, RDTSHELF, and RDTSLLOT.
	SITE	alphanumeric	Site. Enter the location of the RDT, a four-character alphanumeric. This entry is not optional, and there is no default value assigned to it.
	RDT FRAME	0-511	RDT frame. Enter the RDT frame number, which is not a physical frame but a software entity that represents the group the RDT belongs to at the site.
	RDT UNIT	0-9	RDT unit. Enter the number representing the RDT unit within the group.
	RDT SHELF	0-20	RDT shelf. Enter the shelf number where the RDT resides. For GENTMC signaling, the range is from 0-20, up to the maximum defined in table RDTINV, based on the size of RDT datafilled.
	RDT SLOT	0-99	RDT slot. Enter the slot number where the RDT resides. For GENTMC signaling, the range is from 0-99, up to the maximum defined in table RDTINV, based on the size of RDT datafilled.
CARDCODE		RDTCON, RDTLSG, RDTISD or RDTMPY	Card code. Enter the PEC of the line card or line card carrier. The following identifies the respective object class type for the card code values represented. <ul style="list-style-type: none"> • RDTCON coin • RDTLSG loop start/ground start • RDTISD ISDN • RDTMPY multiparty

TR-303 Generic Interface (continued)**Datafilling table LNINV (Sheet 2 of 2)**

Field	Subfield or refinement	Entry	Explanation and action
PADGRP		STDLN, UNBAL, LRLM or NPDGP	Pad group. Enter the name of the pad group assigned to the line circuit in table PADDATA. Pads can be applied on the lines at the SMA2.
STATUS		HASU, WORKING, UNEQUIP, CUTOFF or RESERVED	Status. Enter the line inventory availability status.
GND		Y or N	Ground. Where line is ground start, enter Y. Otherwise, enter N for loop start.
BNV		L or NL	Balanced network value. Enter L when line circuit is configured for a loaded network. Otherwise, enter NL for nonloaded network.
MNO		Y or N	Manual override. Enter Y when on-hook balance network test is prevented from updating field BNV. Otherwise, enter N to allow off-hook balance network test to update field BNV.
CARDINFO		RDT C, RDT S, or NIL	Card information. When RDT is selected, the system presents a subfield prompting for C or S, where RDT C is synonymous with coded ringing, and RDT S is synonymous with superimposed ringing. RDT C or RDT S is permitted if table RDTINV field VARTYPE is datafilled as GENTMC. The default value is NIL.

Datafill example for table LNINV

The following example shows sample datafill for table LNINV.

MAP display example for table LNINV

LEN	CARDCODE	PADGRP	STATUS	GND	BNV
MNO	CARDINFO				
CARY 01 0 06 72	RDTLGS	STDLN	HASU	N	NL
N	RDT C				

TR-303 Generic Interface (continued)

Error messages for table LNINV

The following error messages apply to table LNINV.

Error message for table LNINV

Error message	Explanation and action
Error - invalid cardtype entered for this line card	Attempt of a RDT cardinfo datafill on a non-MVI RDT line. VARTYPE field in table RDTINV is not GENTMC.

Datafilling table RDTLT

Table remote digital terminal line termination (RDTLT) contains information about the next operation to be performed by the line object provisioning process, on a line connected to the RDT and identified by the LEN of the line card. This table correlates the LEN of the line card to the status of the message flow, about the line-related objects between the DMS switch and the RDT.

A tuple is added to this table when a new line is datafilled for the RDT in table LNINV. A tuple for this table is deleted when a line connected to the RDT is deleted. Updates to the tuple are made from LNINV table control, or from line provisioning process software, except during dump and restore processes. Table RDTLT is a *read-only* table.

The following table shows the fields that are automatically datafilled for table RDTLT. The following table is provided for information only.

Datafilling table RDTLT (Sheet 1 of 10)

Field	Subfield or refinement	Entry	Explanation and action
LEN		see subfields	Line equipment number. This field defines the physical location of the equipment that is connected to a specific telephone line. For ISDN lines, field LEN consists of subfield LTID. For non-ISDN lines, field LEN consists of subfields SITE, FRAME, UNIT, DRAWER or LSG, SHELF, SLOT, and CIRCUIT.
ACCESS		see below	Line provisioning process operation. This field identifies the operation performed by the line provisioning process for an RDT line.
		ACCESS_NIL	No operations are required.

TR-303 Generic Interface (continued)

Datafilling table RDTLT (Sheet 2 of 10)

Field	Subfield or refinement	Entry	Explanation and action
		I_ACCESS_DONE	Line objects provisioning for ISDN line done.
		I_CHA_IPTIS_CONF	Waiting for response to message: CHANGE PRIMARY STATE OF ISDN PATH TERMINATION (PT) TO IN SERVICE
		I_CHA_IPTIS_REQ	Send message: CHANGE PRIMARY STATE OF ISDN PT OBJECT TO IN SERVICE
		I_CHA_IPTOOS_CONF	Waiting for response to message: CHANGE PRIMARY STATE OF ISDN PT TO OUT OF SERVICE
		I_CHA_IPTOOS_CONF 1	Waiting for response to message: CHANGE PRIMARY STATE OF ISDN PT TO OUT OF SERVICE
		I_CHA_IPTOOS_REQ	Send message: CHANGE PRIMARY STATE OF ISDN PT OBJECT TO OUT OF SERVICE
		I_CHA_IPTOOS_REQ1	Send message: CHANGE PRIMARY STATE OF ISDN PT OBJECT TO OUT OF SERVICE
		I_CHA_LTIS_CONF	Waiting for response to message: CHANGE PRIMARY STATE OF ISDN LINE TERMINATION (LT) TO IN SERVICE
		I_CHA_LTIS_REQ	Send message: CHANGE PRIMARY STATE OF ISDN LT OBJECT TO IN SERVICE
		I_CHA_LTO-OS_CONF	Waiting for response to message: CHANGE PRIMARY STATE OF ISDN LT TO OUT OF SERVICE

TR-303 Generic Interface (continued)**Datafilling table RDTLT (Sheet 3 of 10)**

Field	Subfield or refinement	Entry	Explanation and action
		I_CHA_LTO-OS_CONF 1	Waiting for response to message: CHANGE PRIMARY STATE OF ISDN LT TO OUT OF SERVICE
		I_CHA_LTO-OS_REQ	Send message: CHANGE PRIMARY STATE OF ISDN LT OBJECT TO OUT OF SERVICE
		I_CHA_LTO-OS_REQ1	Send message: CHANGE PRIMARY STATE OF ISDN LT OBJECT TO OUT OF SERVICE
		I_CRE_A1DCT_CONF	Waiting for response to message: CREATE FIRST DS-0 CHANNEL TERMINATION (CT) OBJECT
		I_CRE_A1DCT_REQ	Send message: CREATE FIRST DS-0 CT OBJECT
		I_CRE_A2DCT_CONF	Waiting for response to message: CREATE SECOND DS-0 CT OBJECT
		I_CRE_A2DCT_REQ	Send message: CREATE SECOND DS-0 CT OBJECT
		I_CRE_AQDCT_CONF	Waiting for response to message: CREATE QDS-0 CT OBJECT
		I_CRE_AQDCT_REQ	Send message: CREATE QDS-0 CT OBJECT
		I_CRE_ICT_CONF	Waiting for response to message: CREATE ISDN CT OBJECT
		I_CRE_ICT_REQ	Send message: CREATE ISDN CHANNEL TERMINATION (CT) OBJECT

TR-303 Generic Interface (continued)

Datafilling table RDTLT (Sheet 4 of 10)

Field	Subfield or refinement	Entry	Explanation and action
		I_CRE_IPT_CONF	Waiting for response to message: CREATE ISDN PT OBJECT
		I_CRE_IPT_REQ	Send message: CREATE ISDN PATH TERMINATION (PT) OBJECT
		I_CRE_LT_CONF	Waiting for response to message: CREATE ISDN LT OBJECT
		I_CRE_LT_REQ	Send message: CREATE ISDN LINE TERMINATION (LT) OBJECT
		I_DEL_IPT_CONF	Waiting for response to message: DELETE PT AND ALL SUBTENDING OBJECTS
		I_DEL_IPT_CONF1	Waiting for response to message: DELETE PT AND ALL SUBTENDING OBJECTS
		I_DEL_IPT_REQ	Send message: DELETE ISDN PT AND ALL SUBTENDING OBJECTS
		I_DEL_IPT_REQ1	Send message: DELETE ISDN PT AND ALL SUBTENDING OBJECTS
		I_DEL_IPT_CONF1	Waiting for response to message: DELETE PT AND ALL SUBTENDING OBJECTS
		I_DEL_IPT_REQ	Send message: DELETE ISDN PT AND ALL SUBTENDING OBJECTS

TR-303 Generic Interface (continued)**Datafilling table RDTLT (Sheet 5 of 10)**

Field	Subfield or refinement	Entry	Explanation and action
		I_DEL_IPT_REQ1	Send message: DELETE ISDN PT AND ALL SUBTENDING OBJECTS
		I_DEL_LT_CONF	Waiting for response to message: DELETE LT AND ALL SUBTENDING OBJECTS
		I_DEL_LT_CONF1	Waiting for response to message: DELETE LT AND ALL SUBTENDING OBJECTS
		I_DEL_LT_REQ	Send message: DELETE ISDN LT AND ALL SUBTENDING OBJECTS
		I_DEL_LT_REQ1	Send message: DELETE ISDN LT AND ALL SUBTENDING OBJECTS
		P_ACCESS_DONE	Line objects provisioning for analog or electronic business set (EBS) line done.
		P_CHA_LTIS_CONF	Waiting for response to message: CHANGE PRIMARY STATE OF LINE TO IN SERVICE
		P_CHA_LTIS_REQ	Send message: CHANGE PRIMARY STATE OF LINE TO IN SERVICE
		P_CHA_LTOOS_CONF	Waiting for response to message: CHANGE PRIMARY STATE OF LINE TO OUT OF SERVICE
		P_CHA_LTOOS_CONF 1	Waiting for response to message: CHANGE PRIMARY STATE OF LINE TO OUT OF SERVICE

TR-303 Generic Interface (continued)**Datafilling table RDTLT (Sheet 6 of 10)**

Field	Subfield or refinement	Entry	Explanation and action
		P_CHA_LTOOS_REQ	Send message: CHANGE PRIMARY STATE OF LINE TO OUT OF SERVICE
		P_CHA_LTOOS_REQ1	Send message: CHANGE PRIMARY STATE OF LINE TO OUT OF SERVICE
		P_CRE_LT_CONF	Waiting for response to message: CREATE ANALOG OR EBS LT OBJECT
		P_CRE_LT_REQ	Send message: CREATE ANALOG OR EBS LINE TERMINATION (LT) OBJECT
		P_DEL_LT_CONF	Waiting for response to message: DELETE LT AND ALL SUBTENDING OBJECTS
		P_DEL_LT_CONF1	Waiting for response to message: DELETE LT AND ALL SUBTENDING OBJECTS
		P_DEL_LT_REQ	Send message: DELETE LT AND ALL SUBTENDING OBJECTS
		P_DEL_LT_REQ1	Send message: DELETE LT AND ALL SUBTENDING OBJECTS
		P_MOD_LT_CONF	Waiting for response to message: MODIFY LT OBJECTS
		P_MOD_LT_REQ	Send message: MODIFY ANALOG OR EBS LINE TERMINATION OBJECT

Note: The above mentioned values that end with 1 are for delete and create operations.

TR-303 Generic Interface (continued)**Datafilling table RDTLT (Sheet 7 of 10)**

Field	Subfield or refinement	Entry	Explanation and action
TRANSP		see below	Rdt line processor transport states. This field identifies the next operation to be performed by the line provisioning process for creating the objects for the transport portion of the cross-connect.
		TRANSP_NIL	No operations are required.
		TRANSP_DONE	All operations complete.
		I_ADD_TDPT_CONF	Waiting for response to message: UPDATE DS-0 CT OBJECT
		I_ADD_TDPT_REQ	Send message: UPDATE TRANSPORT SIDE DS-0 CT OBJECT TO INCLUDE DS0 PT OBJECT
		I_CHA_TDPTIS_CONF	Waiting for response to message: CHANGE PRIMARY STATE OF DS-0 PT TO OUT OF SERVICE
		I_CHA_TDPTIS_REQ	Send message: CHANGE PRIMARY STATE OF DS-0 PT OBJECT TO IN SERVICE
		I_CHA_XCOOS_CONF1	No current use.
		I_CHA_XCOOS_REQ1	No current use.
		I_CRE_TDPT_CONF	Waiting for response to message: CREATE DS-0 PT OBJECT
		I_CRE_TDPT_REQ	Send message: CREATE TRANSPORT SIDE DS-0 PATH TERMINATION (PT) OBJECT
		I_CRE_TQDCT_CONF	Waiting for response to message: CREATE QDS-0 CT OBJECT

TR-303 Generic Interface (continued)**Datafilling table RDTLT (Sheet 8 of 10)**

Field	Subfield or refinement	Entry	Explanation and action
		I_CRE_TQDCT_REQ	Send message: CREATE TRANSPORT SIDE QDS-0 CT OBJECT
		I_CRE_XC_CONF	Waiting for response to message: CROSS CONNECTION OBJECT
		I_CRE_XC_REQ	Send message: CREATE TRANSPORT SIDE CROSS CONNECTION OBJECT
		I_DEL_TDPT_CONF	Waiting for response to message: DELETE DS-0 PT OBJECT
		I_DEL_TDPT_REQ	Send message: DELETE DS-0 PT OBJECT
		I_DEL_TQDCT_CONF	Waiting for response to message: DELETE QDS-0 CT OBJECT
		I_DEL_TQDCT_CONF1	Waiting for response to message: DELETE QDS-0 CT OBJECT
		I_DEL_TQDCT_REQ	Send message: DELETE QDS-0 CT OBJECT
		I_DEL_TQDCT_REQ1	Send message: DELETE QDS-0 CT OBJECT
		I_DEL_XC_CONF	Waiting for response to message: DELETE CROSS CONNECTION OBJECT
		I_DEL_XC_CONF1	Waiting for response to message: DELETE CROSS CONNECTION OBJECT
		I_DEL_XC_REQ	Send message: DELETE CROSS CONNECTION OBJECT

TR-303 Generic Interface (continued)

Datafilling table RDTLT (Sheet 9 of 10)

Field	Subfield or refinement	Entry	Explanation and action
		I_DEL_XC_REQ1	Send message: DELETE CROSS CONNECTION OBJECT
Note: The above mentioned values that end with 1 are for delete and create operations.			
CONTMARK		+ or \$	Enter + if additional information for this tuple is contained in the next record. Otherwise, enter \$ to indicate the end of the tuple.
REQUESTR		see below	Requesting process. This field allows table control to display the process that is using RDTLT resources. The information below allows the table control software to determine where the request was initiated from.
		REQUESTOR_NIL	No requestor
		REQUESTOR_RDTLP	Request initiated from RDTLP process.
		REQUESTOR_DUMPREST	Request initiated from dump and restore process.
		REQUESTOR_JFILE	Request initiated from journal file update process.
CRV		0 to 4095	Call reference value range. This field represents the call reference value range.
LOPDONE		Y or N	Line object provisioning done. This field is set to Y (yes) when all line object provisioning is complete.
DELALL		Y or N	Delete all tuples. This field is set to Y (yes) when a request has been accepted by the table control software to delete all entries in table RDTLT.

TR-303 Generic Interface (continued)**Datafilling table RDTLT (Sheet 10 of 10)**

Field	Subfield or refinement	Entry	Explanation and action
LTIS		Y or N	Line termination in-service. This field is set to Y (yes) when the line termination object (LTO) is in service.
INSMOD		Y or N	In service modifier. This field is set to Y (yes) to identify if a request to update the in service attributes of the LTO is sent.

Datafill example for table RDTLT

The following example shows sample datafill for table RDTLT.

MAP display example for table RDTLT

```

RDTLTKEY      ACCESS          TRANSP          NAILUP1
  NAILUP2     REQUESTR      CRV  LOPDONE  DELALL  LTIS  INSMOD
LTCLASS       QDS0INFO          XCINFO
-----
CARY 03 0 2 1  P_ACCESS_DONE  TRANSP_NIL  NAILUP_NIL
  NAILUP_NIL  REQUESTR_NIL  201    Y    N    Y    N
ANALOG_LT    0 0 0 0          0 0 0

```

Datafilling table LENLINES

Table LENLINES contains the following data:

- site name assigned to remote location
- party where DN is assigned
- ringing code assigned to a DN

Note: An RDT-related tuple can only be added in this table if the CARDCODE field in table LNINV is RDTLSG, RDTCON or RDTMPY.

Datafilling table SCGRP

Table scan group (SCGRP) lists the PEC and physical location of scan groups that provide scan points for line features. Each scan card provides a total of 14 scan points subdivided into two scan groups. Each scan group is assigned to a TM circuit number.

Note: Lines at a remote location must be assigned to scan points belonging to scan groups located at the remote location.

TR-303 Generic Interface (continued)

Table SDGRP is required datafill for setting up mechanized loop testing of RDT subscriber lines. The SD groups used in mechanized loop testing are defined in this table. The SD points that drive the applique circuit used in mechanized loop testing, are defined in table LTDS.

The following table shows the datafill specific to TR-303 Generic Interface for table SCGRP. Only those fields that apply directly to TR-303 Generic Interface are shown.

Datafilling table SCGRP

Field	Subfield or refinement	Entry	Explanation and action
SCGRPNO		0-511	Scan group. Enter the scan group number.
TMTYPE		MTM, RMM, or RSM	Trunk module type. Enter the type of trunk module where the miscellaneous scan card is mounted.
TMNO		0-255	Trunk module number. Enter the number assigned to the MTM, RMM, or RSM where the miscellaneous scan card is mounted.
TMCKTNO		0-23	Trunk module circuit number. Enter the trunk module circuit number on the MTM, RMM or RSM, the scan group is assigned.
CARDCODE		0X10AA	Enter the PEC of the scan card.

Datafill example for table SCGRP

The following example shows sample datafill for table SCGRP.

MAP display example for table SCGRP

SCGRPNO	TMTYPE	TMNO	TMCKTNO	CARDCODE
0	MTM	1	14	0X10AA
1	MTM	1	15	0X10AA
2	RSM	1	12	0X10AA
3	RSM	1	13	0X10AA

Datafilling table SDGRP

Table signal distributor group (SDGRP) lists the PEC and physical location of SD groups that provide SD points for line features. Each SD card provides 14

TR-303 Generic Interface (continued)

SD points subdivided into two SD groups. Each SD group is assigned to a TM circuit number.

Note: Lines at a remote location must be assigned to SD points belonging to SD groups at the remote location.

Table SDGRP is required datafill for setting up mechanized loop testing of RDT subscriber lines. The SD groups used in mechanized loop testing are defined in this table. The SD points that drive the applique circuit used in mechanized loop testing are defined in table LTDS.

The following table shows the datafill specific to TR-303 Generic Interface for table SDGRP. Only those fields that apply directly to TR-303 Generic Interface are shown.

Datafilling table SDGRP

Field	Subfield or refinement	Entry	Explanation and action
SDGRPNO		0-511	Signal distributor group. Enter the signal distributor group number.
TMTYPE		MTM, RMM or RSM	Trunk module type. Enter the type of trunk module where the signal distributor card is mounted.
TMNO		0-2047	Trunk module number. Enter the number assigned to the MTM, RMM or RSM where the signal distributor card is mounted.
TMCKTNO		0-29	Trunk module circuit number. Enter the trunk module circuit number on the MTM, RMM, or RSM, where the signal distributor group is assigned.
CARDCODE		2X57AA	Cardcode. Enter the PEC of the signal distributor card.

Datafill example for table SDGRP

The following example shows sample datafill for table SDGRP.

TR-303 Generic Interface (continued)

MAP display example for table SDGRP

SDGRPNO	TMTYPE	TMNO	TMCKTNO	CARDCODE
0	MTM	0	14	2X57AA
1	MTM	0	15	2X57AA
2	RSM	0	14	2X57AA
3	RSM	0	15	2X57AA

Datavfilling table LTSD

Table line test desk signal distribution (LTSD) identifies the SD points used to drive the applique circuit during mechanized loop testing. The applique circuit, used in conjunction with a NT2X90AD test trunk, reports line card diagnostic results to mechanized loop testing equipment, such as a mechanized loop tester or local test desk.

The applique circuit uses four SD points. These points belong to one or more SD groups defined in table SDGRP. This table must be datafilled before table LTSD. SD points need not belong to the same SD group.

Table LTSD must be datafilled after table TRKMEM. Table TRKMEM is used as a key identification into table LTSD. Valid trunk group members belong to trunk group type test desk (TD), version MLT or TSTDK.

The following table shows the datafill specific to TR-303 Generic Interface for table LTSD. Only those fields that apply directly to TR-303 Generic Interface are shown.

Datavfilling table LTSD (Sheet 1 of 2)

Field	Subfield or refinement	Entry	Explanation and action
TDMEM		see subfields	Trunk member. This field consists of subfields CLLI and MEMNAME.
	CLLI	alphanumeric	Common language location identifier. Enter the code assigned in table CLLI.
	MEMNAME	0-9999	Trunk member name. Enter the trunk member that uses the SD circuit card.
TDSGRP1		0-511	Test desk signal distribution group 1. Enter the SD group where the first SD point belongs.

TR-303 Generic Interface (continued)**Datafilling table LTDS D (Sheet 2 of 2)**

Field	Subfield or refinement	Entry	Explanation and action
TDS DPT1		0-6	Test desk signal distribution point 1. Enter the number of the first SD point that drives relay DS-1 in the applique circuit.
TDS DGRP2		0-511	Test desk signal distribution group 2. Enter the SD group where the second SD point belongs.
TDS DPT2		0-6	Test desk signal distribution point 2. Enter the number of the second SD point that drives the relay DS2 in the applique circuit.
TDS DGRP3		0-511	Test desk signal distribution group 3. Enter the SD group where the third SD point belongs.
TDS DPT3		0-6	Test desk signal distribution point 3. Enter the number of the third SD point that drives relay DS3 in the applique circuit.
TDS DGRP4		0-511	Test desk signal distribution group 4. Enter the SD group where the fourth SD point belongs.
TDS DPT4		0-6	Test desk signal distribution point 4. Enter the number of the fourth SD point that drives relay DS4 in the applique circuit.

Datafill example for table LTDS D

The following example shows sample datafill for table LTDS D.

MAP display example for table LTDS D

```

TDMEM TDS DGRP1 TDS DPT1 TDS DGRP2 TDS DPT2 TDS DGRP3 TDS DPT3
TDS DGRP4 TDS DPT4
-----
MLTTRK 1      6      5      6      6      7      0
          7      1

```

Datafilling table MTAMDRVE

Table metallic test access minibar driver (MTAMDRVE) is a matrix of vertical and horizontal crosspoints, comparable to a minibar circuit, that connect specified verticals to horizontal within the network.

TR-303 Generic Interface (continued)

The metallic test access (MTA) is used to connect test equipment, which is connected to a horizontal crosspoint, to a circuit that requires testing through a test bypass pair that is connected to a vertical crosspoint.

A MTA network of the required size can be constructed by the interconnection of a number of smaller minibar circuits, which are used as building block components, as shown in the following figure.

The NT3X09AA driver is used to allow metallic test access to remote line concentrating devices, including the RDT. The NT3X09AA is a four vertical-by-eight horizontal circuit. The NT3X09BA is an eight vertical-by-eight horizontal circuit.

MTA matrix

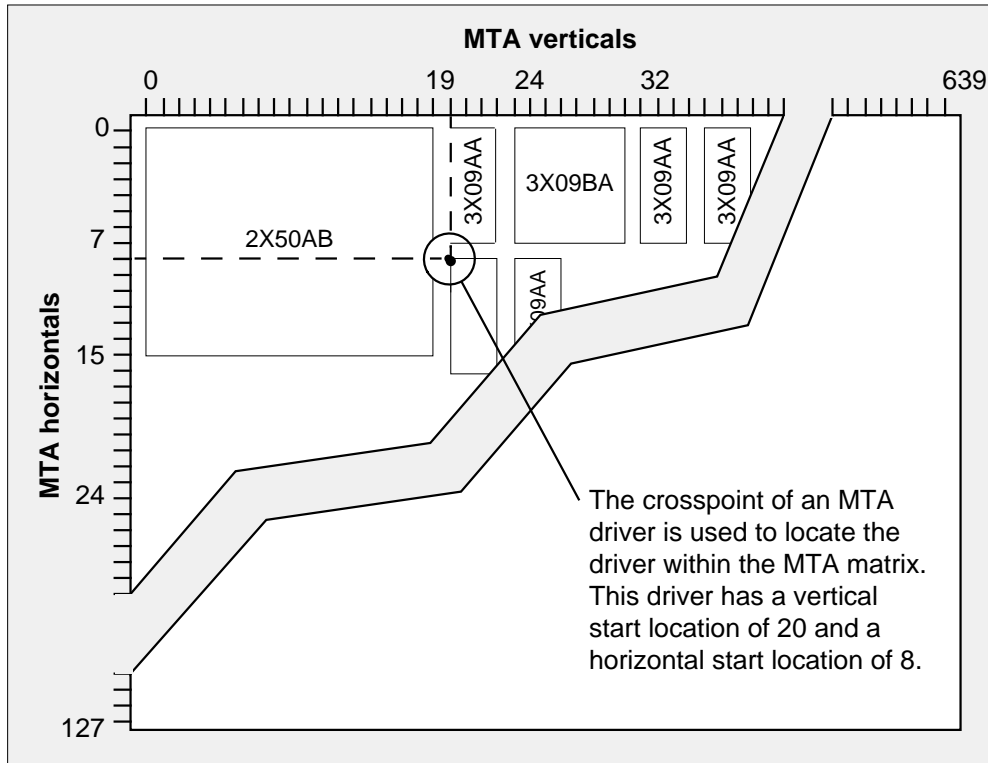
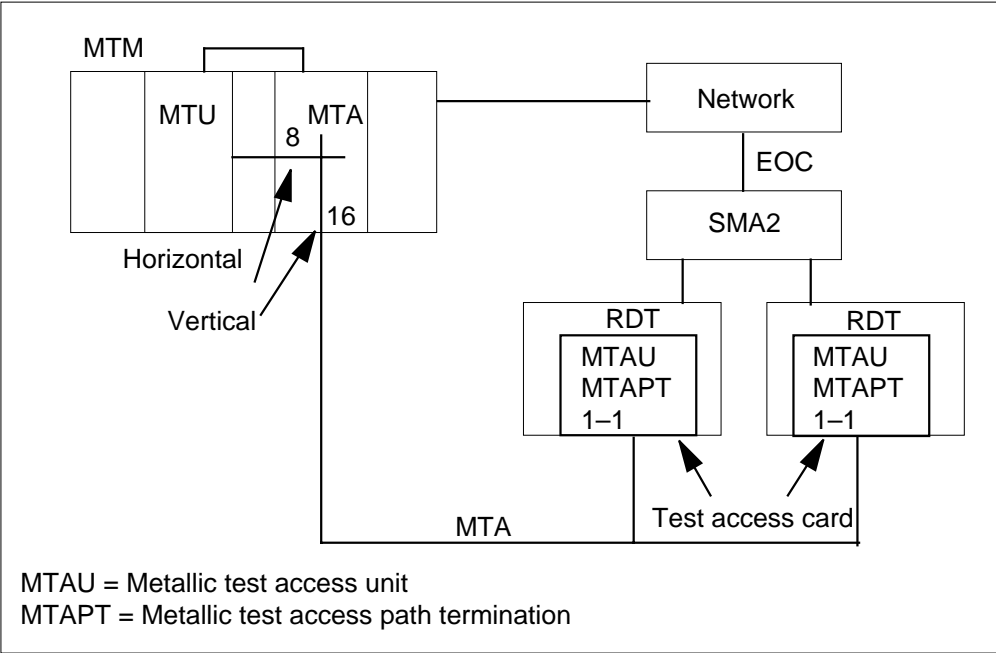


Table MTAMDRVE specifies the physical location and the type of MTA. The NT3X09 driver has relays on the card itself and does not require an associated minibar switch. Each MTA is identified by its 0, 0 crosspoint in the matrix.

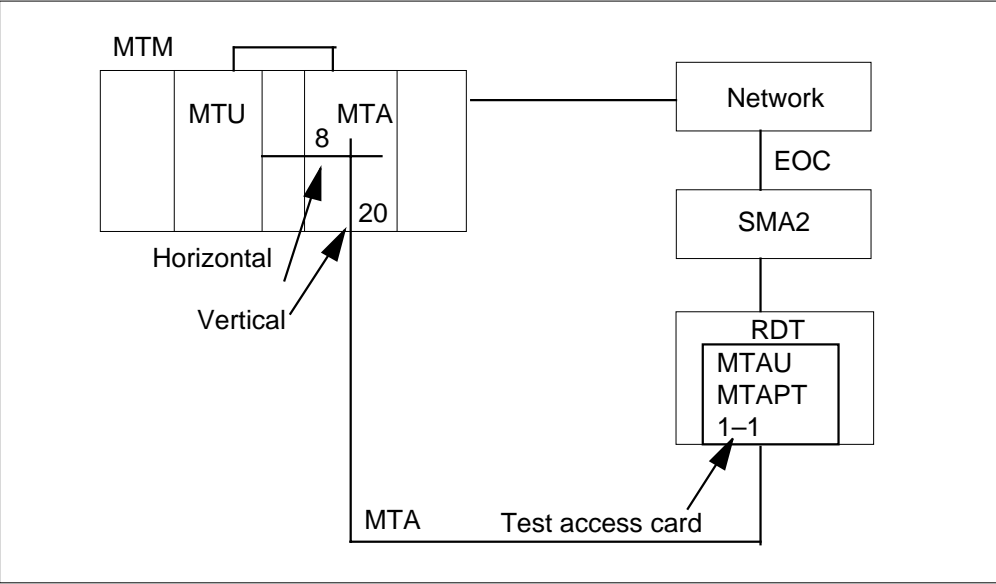
The following figures correspond to the MTA datafill examples throughout the end of this chapter.

TR-303 Generic Interface (continued)

Multiple RDTs on one test bypass pair



Metallic test bypass for only one RDT



TR-303 Generic Interface (continued)

The following table shows the datafill specific to TR-303 Generic Interface for table MTAMDRVE. Only those fields that apply directly to TR-303 Generic Interface are shown.

Datafilling table MTAMDRVE

Field	Subfield or refinement	Entry	Explanation and action
MTAMEM		0-255	Metallic test access minibar driver member. Enter the MTA driver member number. This is the key into this table.
VERT		0-639	MTAM driver vertical start location. Enter the vertical start location for the MTAM driver.
HORIZ		0-127	MTAM driver horizontal start location. Enter the horizontal start location for the MTAM driver.
TMTYPE		MTM	Trunk module type. Enter the type of trunk module where the MTA is mounted.
TMNO		0-255	Trunk module number. Enter the number assigned to the maintenance trunk module.
TMCKTNO		0-28 (even numbers)	Trunk module circuit number. Enter the circuit number of the MTM where the MTA is assigned.
MTACARD		2X50AB, 3X09AA, or 3x09BA	MTAM driver card. Enter the card code for the MTA card.

Datafill example for table MTAMDRVE

The following example shows sample datafill for table MTAMDRVE.

MAP display example for table MTAMDRVE

MTAMEM	VERT	HORIZ	TMTYPE	TMNO	TMCKTNO	MTACARD
1	20	8	MTM	1	10	3X09BA

Datafilling table MTAVERT

Table metallic test access vertical connection (MTAVERT) identifies the vertical connectivity to the MTA matrix. Table MTAVERT is modified so that one or two verticals can be datafilled for one or more RDTs.

Two types of connections are allowed: single and multiple. The SMA2 system uses the multiple connection. Up to 32 RDTs can share a metallic test pair.

TR-303 Generic Interface (continued)

The following table shows the datafill specific to TR-303 Generic Interface for table MTAMDRVE. Only those fields that apply directly to TR-303 Generic Interface are shown.

Datafilling table MTAVERT

Field	Subfield or refinement	Entry	Explanation and action
VERT		0-1023	Vertical. Enter the MTA vertical connection number.
VERTCONN		S or M	Vertical connection. Enter either S or M to indicate single or multiple connections. For multiple connections, up to 32 RDTs can share a metallic test pair.
	SELECTOR	O or L	Selector. When selector O is used, the entry in VERTCONN is M. The subfields SITE, FRAME, and UNIT must be datafilled after the selector. This is a vector of up to 32 entries. When L is used, the entry in VERTCONN is S. The subfields SITE, FRAME, and UNIT must be datafilled.
	SITE	alphanumeric	Site. Enter the name selected for the remote location.
	FRAME	0-511	Frame. Enter the frame number.
	UNIT	0-9	Unit number. Enter the unit number.
	CONTMARK	+ or \$	Continuation mark. Enter a plus sign (+) when additional data is specified on the next record. Otherwise, enter a dollar sign (\$) after last record.

Datafill example for table MTAVERT

The following example shows sample datafill for table MTAVERT.

MAP display example for table MTAVERT

VERT	VERTCONN
16	M (O RDT1 00 0)
17	S (O RDT1 02 0)
18	S (O RDT1 03 0)
19	S (L RDT1 04 0)

TR-303 Generic Interface (continued)

Datafilling table MTAHORIZ

Table metallic test access horizontal connection (MTAHORIZ) lists the assignment of horizontal agents to a horizontal and horizontal group of metallic test access minibars. Horizontal agents include metallic test units (MTU), operator verification, metallic jacks (MJACK), incoming test access trunks, extended metallic test access, and short circuits.

Different horizontal agents may use the same horizontal but must be associated with different metallic test access minibars or horizontal groups. A maximum of 160 different horizontal agents is allowed for a given horizontal.

A maximum of 32 MTAMs can be grouped to connect to a single horizontal agent. A horizontal agent can only be used once.

When an LTU is assigned to the host switching unit, the horizontal where it is assigned is multiplied to all minibar switches assigned to the host switching unit.

When an LTU is assigned to a remote location, the horizontal where it is assigned is multiplied to all minibar switches assigned to the remote location.

When the minibar switch is located at the host switching unit, no assignment restriction exists for the assignment of incoming test and operator verification trunks. One horizontal is required for each incoming test access trunk and operator verification trunk.

Where the MTA configuration is small or medium, the horizontals where the incoming test access. Operator verification trunks are assigned and multiplied to all minibar switches located at the host switching unit.

When the minibar switch is remote from the host switching unit, all horizontals are available for the assignment of incoming test access trunks, operator verification trunks, and for the extension of metallic test access feature.

One horizontal is required for each incoming test access trunk, operator verification trunk, and for each vertical on the host minibar switch assigned to a horizontal on the minibar switch located at the remote or host location.

The number of metallic jacks in each DMS switch is restricted to 256.

For assignment of LTUs, incoming test access, and operator verification trunks, to trunk group, trunk subgroup, and trunk member tables, see tables TRKGRP, TRKSGRP, and TRKMEM respectively.

TR-303 Generic Interface (continued)

An MTU must be datafilled in table TRKMEM before being added to table MTAHORIZ. If the MTU is deleted from table TRKMEM, the corresponding tuple in table MTAHORIZ is marked as deleted, and automatically restored if the MTU is added again to table TRKMEM.

The memory for this table is dynamically allocated up to a maximum of 2000 tuples.

The LTU is replaced by the MTU. When datafilling for an LTU, a warning may appear at the MAP terminal explaining; the correct datafill is MTU.

The following table shows the datafill specific to TR-303 Generic Interface for table MTAHORIZ. Only those fields that apply directly to TR-303 Generic Interface are shown.

Datafilling table MTAHORIZ (Sheet 1 of 3)

Field	Subfield or refinement	Entry	Explanation and action
HORIZ		0-127	MTA horizontal. Enter the MTA horizontal where the test equipment (horizontal agent) is connected.
HORIZGRP		0-159	MTA horizontal group. Enter the horizontal group number that identifies the horizontal and its horizontal agent as a unique tuple. The purpose of the horizontal group is to allow assignment of different test equipment on the same MTA horizontal.
HORIZAGT		see subfields	Horizontal agent. This field contains several subfields that depend on the value of SELECTOR used.

TR-303 Generic Interface (continued)

Datafilling table MTAHORIZ (Sheet 2 of 3)

Field	Subfield or refinement	Entry	Explanation and action
	SELECTOR	S, L, T, B, E, MJ, J, and LA	<p>Selector.</p> <p>Enter S for a timed short circuit.</p> <p>Enter L for LTU or MTU assignment, and complete subfields CLLI, EXTRKNM, and ALTUSE.</p> <p>Enter T for incoming test access or operator verification trunk assignment and complete subfields CLLI and EXTRKNM.</p> <p>Enter B for a board-to-board dedicated horizontal, and complete subfield BBTNR.</p> <p>Enter E to multiply a horizontal of a minibar switch from a host or remote to the vertical of a host minibar switch, then complete subfield EMTAVERT.</p> <p>Enter MJ for metallic connection to the tip and ring of the subscriber line, and complete subfields CLLI and MJACKNUM.</p> <p>Selectors J and LA are for licensee use only.</p> <p>Enter NT1 for the test network termination 1 (NT1) and complete subfield NT1NUM.</p>
	CLLI	LTU, MTU, MJACK, or alphanumeric	<p>Common language location identifier. Enter LTU for line test unit. Enter MTU for metallic test unit.</p> <p>For operator verification or an incoming test access trunk, enter the alphanumeric code that represents this trunk group in table CLLI.</p> <p>Enter MJACK for metallic jack.</p>
	EXTRKNM	0-9999	<p>External trunk number. Enter the external trunk number assigned in table TRKMEM to the line test unit, metallic test unit, operator verification trunk, or the incoming test access trunk.</p>
	ALTUSE	Y or N	<p>Automatic line test use. Enter Y to use line test equipment for automatic line testing (ALT). Otherwise, enter N.</p>

TR-303 Generic Interface (continued)**Datafilling table MTAHORIZ (Sheet 3 of 3)**

Field	Subfield or refinement	Entry	Explanation and action
	BBTNR	0-7	Board-to-board testing number. Enter the number of the board-to-board set where this horizontal is associated.
	EMTAVERT	0-639	Extended metallic test access column. Enter the associated vertical on the MTA in the host where the horizontal is connected.
	MJACKNUM	1-256	Metallic jack number. Where the entry in subfield CLLI is MJACK, enter the metallic jack number.
	NT1NUM	0 to 255	Network termination 1 number. Enter the number of the test NT1 in the DMS testing system with which this horizontal connection is associated.
MTAGRP		numeric	MTA group. This field consists of a list of MTA drivers that multiply to the test equipment. This field is a vector of up to 32 multiples of subfields MTAMEM and HORIZ.
	MTAMEM	0-255	MTA minibar driver member. Enter the MTAM driver member number where the horizontal is connected.
	HORIZ	0	This field is read-only. It provides information about the physical horizontal where the MTA drivers are connected. Enter 0 to satisfy table control.
	CONTMARK	+ or \$	Continuation mark. Enter a plus sign (+) when additional data is specified on the next record. Otherwise, enter a dollar sign (\$) after the last record.

Datafill example for table MTAHORIZ

The following example shows sample datafill for table MTAVERT.

MAP display example for table MTAHORIZ

HORIZ	HORIZGRP	HORIZAGT	MTAGRP
8	0	L	MTU 0 Y (0 0) (2 0)\$

TR-303 Generic Interface (continued)

Datafilling table AMAOPTS

Table AMA options (AMAOPTS) controls the activation and scheduling of the recording options for automatic message accounting (AMA). Table AMAOPTS contains one tuple for each option, and initially contains the default values for each option.

The following table shows the datafill specific to the TR-303 Generic Interface for table AMA options (AMAOPTS). Only those fields that apply directly to TR-303 Generic Interface are shown.

Datafilling table AMAOPTS

Field	Subfield or refinement	Entry	Explanation and action
OPTION			Option. This field consists of subfield AMAOPT.
	AMAOPT	DSCWID_ CONF_AUDIT	DSCWID conference audit. Key field in table AMAOPTS.
SCHEDULE			Schedule. This field consists of many subfields. Subfield AMASEL is shown.
	AMASEL	PERIODIC, OFF, or DEFAULT	AMA option selected. Selects either audit OFF or PERIODIC. Default is OFF.

Datafill example for table AMAOPTS

The following example shows sample datafill for table AMAOPTS.

MAP display example for table AMAOPTS

OPTION	SCHEDULE
DSCWID_CONF_AUDI	OFF

Datafilling table TEXTPHRS

Table text phrases (TEXTPHRS) is used by virtual screen list editing (VSLE) and other display features. It contains instructional and prompting text strings that make up individual logical display phrases.

TR-303 Generic Interface (continued)

The following table shows the datafill specific to TR-303 Generic Interface for table text phrases (TEXTPHRS). Only those fields that apply directly to TR-303 Generic Interface are shown.

Datafilling table TEXTPHRS

Field	Subfield or refinement	Entry	Explanation and action
PHRSNAME		alphanumeric	Phrase name. Enter the 2 to 8 character name of the physical phrase used in table TEXTLOG.
PHRASE		alphanumeric	Phrase. Enter the test string displayed to the user as instructional or prompting messages. This field is a vector of up to 40 characters.
HLMODE		see subfields	High light mode. This field contains subfields POSITION and MODE.
	POSITION	0 to 40	POSITION. Specifies the character position of the change.
	MODE	Normal, Reverse, Grey, or Bold	MODE Enter the value range.

Datafill example for table TEXTPHRS

The following example shows sample datafill for table TEXTPHRS.

TR-303 Generic Interface (continued)

MAP display example for table TEXTPHRS

PHRSNAME	PHRASE HLMODE
CLCOUNT	GENERIC_CALLOG_ITEM_COUNT
CLNEWCT	GENERIC_CALLOG_NEW_COUNT
CLOLDCT	GENERIC_CALLOG_OLD_COUNT
CLNAMEIT	GENERIC_CALLOG_NAME_ITEM
CLDNIT	GENERIC_CALLOG_DN_ITEM
CLPRIM	GENERIC_CALLOG_PRIMARY
CLCURNUM	GENERIC_CALLOG_ITEM_NUMBER
CLTITLE	Call_Logging_Service
CLOLD	_Old
CLNEW	_New_
CLDIAL	Dialing...'
CLREMOVE	Removed...'
CLERASED	Erased_All_Calls
CLDNLD1	Processing_
CLDNLD2	_Calls
CLEMPY	No_Calls...Hang_up
CLNODIAL	Cannot_Return_Call
CLCLOSE	Session_Complete

Datafilling table TEXTLOG

Table logical display text (TEXTLOG) is used by VSLE and other display features. Table TEXTLOG contains the names of the physical phrases that make up a logical display phrase.

The following table shows the datafill specific to TR-303 Generic Interface for table logical display text (TEXTLOG). Only those fields that apply directly to TR-303 Generic Interface are shown.

Datafilling table TEXTLOG (Sheet 1 of 2)

Field	Subfield or refinement	Entry	Explanation and action
LPHRSKEY		see subfields	Logical phrase key. Contains subfields application name, language, and display number.
	APPLNAME	VSLE , DSCWID, or CALLOG	Application name. Enter the name of the feature application this tuple uses.

TR-303 Generic Interface (continued)**Datafilling table TEXTLOG (Sheet 2 of 2)**

Field	Subfield or refinement	Entry	Explanation and action
	LANGUAGE	NILANG, LANG1, or LANG2	Language. Enter the language used for the display.
	DISPNUM	0 to 127	Display number. Enter the numeric index the feature application identifies the display data in the tuple.
DISPTYPE		S, T, or C	Display type. Enter S for standard display, T for transient display, or C for cursor control.
LRCI		CENTER, RIGHT, LEFT, or INDENT	Left right center indent. This is the display justification indicator field. Enter the desired mode of justification.
PHRSLIST		alphanumeric	Phrase list. Enter the list of physical phrase names as defined in table TEXTPHRS.
DEFNLIST		see subfields	Definer list. Contains subfields SOFTKEY, MODE, and SKT.
	SOFTKEY	1 to 33	Softkey definer number from the list of softkey definer numbers defined in field DEFNUM of table SOFTKEY.
	MODE	N, H	Mode. Value is N for normal or H for highlight.
	SKT	SRV or CPE	Softkey table. Indicates which softkey table is loaded in the CPE.

Datafill example for table TEXTLOG

The following example shows sample datafill for table TEXTLOG

MAP display example for table TEXTLOG

LPHRSKEY	DISPTYPE	LRCI	PHRSLIST	DEFNLIST
CALLOG	LANG1	1	S	LEFT
				(CLTITLE)\$
				(1 N SRV)\$

TR-303 Generic Interface (continued)

Datafilling table SOFTKEY

Table SOFTKEY specifies softkey information for application services. The index into table SOFTKEY is an application service identifier, and a softkey definer number. Entries in table SOFTKEY are referenced by table TEXTLOG.

The following table shows the datafill specific to TR-303 Generic Interface for table SOFTKEY. Only those fields that apply directly to TR-303 Generic Interface are shown.

Datafilling table SOFTKEY

Field	Subfield or refinement	Entry	Explanation and action
SERVID		alphanumeric	Service identifier. Enter a character string that corresponds to a specific application. This field is a vector of 0 to 8 characters.
DEFNUM		2 to 33	Defining numbers. Enter a numeric value to identify a softkey definer for use with the specified application.
LLABEL		alphanumeric	Label. Enter the label that appears on the customer premise equipment (CPE) set display. This label appears on the line above the softkeys. This field is a vector of 1 to 18 characters.
SLABEL		alphanumeric	Subset of label. Enter a string of characters corresponding to the characters in the long label that are not optional. The characters in this field are a subset of the LLABEL field. This field is a vector of 1 to 7 characters.
RETURN		alphanumeric	Return. Enter the character string returned to the DMS switch when the corresponding softkey is pressed. This field is a vector of up to 14, with a range of 0 to 255.

Datafill example for table SOFTKEY

The following example shows sample datafill for table SOFTKEY

TR-303 Generic Interface (continued)**MAP display example for table SOFTKEY**

SERVID	DEFNUM	LLABEL	SLABEL	RETURN
CALLOG	2	UNDO	UNDO	(50) \$
CALLOG	3	UNDO	UNDO	(51 133) \$
CALLOG	4	TOP	TOP	\$
CALLOG	5	BOTTOM	BOT	\$
CALLOG	6	ERASE	ERAS	(52) \$
CALLOG	7	REMOVE	REM	(55 133) \$
CALLOG	8	DIAL	DIAL	(56 133) \$
CALLOG	9	NAME	NAME	(57 133) \$
CALLOG	10	NUMBER	NUM	(48 133) \$
CALLOG	11	NEXT	NEXT	(53) \$
CALLOG	12	BACK	BACK	(54) \$

Datafilling table DSCWDTYP

Table deluxe spontaneous call waiting types (DSCWDTYP) is used to define different DSCWID types. Table DSCWDTYP has a finite size of up to 20 tuples. Six tuples are initially datafilled in this table, using keys: PROPRITY, ADSITIME, ADSICID, NODATA, NOCIDCW, and COMPLETE. The PROPRITY key is used to indicate Proprietary DSCWID. Operating company personnel cannot change or delete the PROPRITY tuple. The only table control function permitted on the other five tuples is the change command. Operating company personnel has the capability of defining up to 14 additional DSCWID types. Once a new tuple is created the NAME field cannot be changed. Operating company personnel can remove or delete a tuple from table DSCWDTYP when field COUNT is set to zero. Field COUNT cannot be changed by operating company personnel.

TR-303 Generic Interface (continued)

The following table shows the datafill specific to TR-303 Generic Interface for table DSCWDTYP. Only those fields that apply directly to the DSCWID feature of TR-303 Generic Interface are shown.

Note: Table DSCWDTYP must be datafilled prior to defining the DSCWID type in table RESOFC.

Datafilling table DSCWDTYP (Sheet 1 of 2)

Field	Subfield or refinement	Entry	Explanation and action
NAME		PROPRITY ADSITIME, ADSICID, NODATA, NOCIDCW, or COMPLETE	DSCWDTYP table key. Enter the name assigned to each DSCWID type. This field consists of up to eight characters. <i>Note:</i> The PROPRITY tuple is fixed to accommodate the proprietary DSCWID feature.
ALERT		SASONLY or SASCAS	Type of alerting tone. Enter the type of alerting supplied.
CID		NOCID, ALLCID, or TIMECID	Caller ID delivery. Enter the type of CID delivered during the DSCWID session. Options are no data (NOCID), all data of CID type (ALLCID), delivery time and date only (TIMECID).
NONADSI		Y or N	Non ASDI. This field permits DSCWID features to be assigned to non-ADSI sets. When set to N, non-ADSI sets can only signal ANSWER and RETURN softkey options. When set to Y, non-ADSI sets can signal all softkey options in the KEYOPTS field.
<p>Note 1: Operating company personnel cannot change or delete the PROPRITY tuple and can only change (not delete) the other 5 initial tuples.</p> <p>Note 2: ALERT type must be SASCAS to display ADSI complaint features. SASONLY alerting type provides a shorter call waiting function and uses less SMA resources for non-ADSI type sets.</p> <p>Note 3: If CID type is ALLCID, a CID feature must be assigned in table RESOFC.</p>			

TR-303 Generic Interface (continued)**Datafilling table DSCWDTYP (Sheet 2 of 2)**

Field	Subfield or refinement	Entry	Explanation and action
COUNT		0 to 99,999	Line count. This field contains the number of lines assigned this DSCWID type. Note: This field cannot be changed by operating company personnel, tuples cannot be deleted from table DSCWDTYP unless the count is 0. The default value is 0.
KEYOPTS		ALL, ANSWER, RETRN, FWD, BUSY, HOLD, DROP, CONF, DROPFRST, and DROPLAST	Softkey options. This field contains the softkey options available on this DSCWID type. The default value is ALL. Note: Changes to fields with multiple entries should be made in the PROMPT mode only.
<p>Note 1: Operating company personnel cannot change or delete the PROPRITY tuple and can only change (not delete) the other 5 initial tuples.</p> <p>Note 2: ALERT type must be SASCAS to display ADSI complaint features. SASONLY alerting type provides a shorter call waiting function and uses less SMA resources for non-ADSI type sets.</p> <p>Note 3: If CID type is ALLCID, a CID feature must be assigned in table RESOFC.</p>			

Datafill example for table DSCWDTYP.

The following example shows sample datafill for table DSCWDTYP.

TR-303 Generic Interface (continued)

MAP display example for table DSCWDTYP

NAME	ALERT	CID	NON	ADSI	COUNT	KEY	OPTS
PROPRITY	SASCAS	ALLCID		N	0		
(ANSWER)	(FWD)	(BUSY)	(HOLD)	(DROP)	(RETRN)	\$	
ADSITIME	SASCAS	TIMECID		N	0		
						(ALL)	\$
ADSICID	SASCAS	ALLCID		N	0		
						(ALL)	\$
NODATA	SASONLY	NOCID		Y	0		
						(ALL)	\$
NOCIDCW	SASCAS	TIMECID		Y	0		
						(ALL)	\$
COMPLETE	SASCAS	ALLCID		Y	0		
						(ALL)	\$

Translation verification tools

TR-303 Generic Interface does not use translation verification tools.

SERVORD

Use the SERVORD, not the table editor, to add and delete tuples to and from table LTMAP, IBNLINES, IBNFEAT, LENLINES, LENFEAT, RESOFC, and RESFEAT. Using the table editor to datafill these tables can result in incompatible features being assigned to the line.

Table LTMAP contains information on ISG numbers, the PM type, the services provided, and the allocation of service channels.



CAUTION

Loss of service

Use SERVORD, instead of the table editor, to add and delete tuples to and from tables LENLINES, IBNFEAT, RESOFC, and RESFEAT. The table editor is only used to datafill test line, and final line data from tape.

Table IBNLINES contains the line assignments for 500 and 2500 sets assigned to MDC, RES, and multiple appearance directory number (MADN) station numbers.

Note: Attendant consoles are datafilled through the table editor in table IBNLINES.

TR-303 Generic Interface (continued)

Table IBNFEAT lists the line features assigned MDC lines in table IBNLINES. One entry is required for each feature assigned to a MDC line.

Note: Final line data is loaded into the switch using the table editor. Additions, deletions, and changes to table IBNFEAT should be made through SERVORD.

Table LENLINES contains the following data:

- site name assigned to remote location
- party where the directory number is assigned
- ringing code assigned to a directory number

Using the table editor to datafill table LENLINES can result in incompatible features being assigned to the line.

Table LENFEAT lists the features assigned to a specific line in table LENLINES.

Table RESFEAT contains the assignment of CLASS features for residential lines.

Table RESOFC contains data pertaining to CLASS features. CLASS features are public network features targeted for the residential market. For each CLASS feature assigned, table RESOFC controls whether the feature is enabled or disabled for the entire office. If disabled no CLASS line can use that feature, even if assigned. Table RESOFC also controls the attributes associated with each feature.

Table CDCLENS lists the LENSs assigned to a customer group that have the Customer Service Change feature. The LENSs assigned in this table can only be assigned in tables IBNLINES or KSETINV.

SERVORD limitations and restrictions

The following SERVORD limitations and restrictions apply to TR-303 Generic Interface:

- Reject attempt to add semi-post paid service to a line on a TR-303 RDT.
- Remove existing restriction for 2FR and 4FR service on a TR-303 RDT. The GND means *no* option is compatible with LCCs of 2FR and 4FR.

TR-303 Generic Interface (continued)

- Reject attempt to add 2FR or 4FR service on a TR-303 RDT if multiparty card code is not used.
- Reject attempt to add message waiting with lamp option on a TR-303 RDT line.

SERVORD prompts

The following table shows the SERVORD prompts used to add a 1FR line to the TR-303 Generic Interface. Reference the *Servord Reference Manual* for a complete description of SERVORD command and prompts.

SERVORD prompts for TR-303 Generic Interface

Prompt	Valid input	Explanation
DN	Numeric	Directory number to be added.
LCC	Alphanumeric	Line class code.
LATA- NAME	Alphanumeric	Local access and transport area name.
LTG	Numeric	Line treatment group.
LEN or LTID	Numeric	Line equipment number or logical terminal id.
OPTION	Alphanumeric or \$	Option(s) assigned to the line.

SERVORD example for adding TR-303 Generic Interface

The following SERVORD example shows how a 1FR line is added to the TR-303 Generic Interface using the NEW command.

TR-303 Generic Interface (continued)

SERVORD example for TR-303 Generic Interface in prompt mode

```

>NEW
and pressing the Enter key.
SONUMBER:   NOW 94 5 11 AM
>
and pressing the Enter key.
DN:
> 2790011
and pressing the Enter key.
LCC:
> 1FR
and pressing the Enter key.
LATANAME:
> NILLATA
and pressing the Enter key.
LTG
>0
and pressing the Enter key.
LEN or LTID:
>RDT1 0 0 2 0
and pressing the Enter key.
OPTION
> $
and pressing the Enter key.

```

SERVORD example for TR-303 Generic Interface in no-prompt mode

```

> NEW 2790011 1FR NILLATA 0 RDT1 0 0 2 0 $

```

Correlating a LEN to the CRV

In the previous examples, RDT1 0 0 2 0 corresponds to a call reference value (CRV) of 20. Operating company personnel should view the combinations of fields SHELF (also known as RDTLSG) and SLOT (also known as RDTCKT) as the CRV or virtual LENs, which is a logical number equal to the line circuit.

For example, if field SHELF is entered as 3, and field SLOT is entered as 4, the RDT LEN represents a CRV of 304. The two fields combined can take a value of 1-2048 where RDT SHELF represents the thousands and hundreds columns (the 20 of 2048) and RDT SLOT represent the tens and units columns (the 48 of 2048).

TR-303 Generic Interface (continued)

SERVORD examples for adding DSCWID options to a subscriber line

The following SERVORD examples show how DSCWID feature is applied to the SMA using the ADO command. Assume in table RESOFC the:

- default DSCWID type (DTYPE) is set to ADSITIME.
- DSCWID conference (AMA) status is set to NONE.
- DSCWID default treatment (DEFTRMT) is set to FWD.

The following example assigns DSCWID to 621-5000 with the default characteristics of DSCWID type ADSITIME.

MAP display of SERVORD Add Option (ADO) command using defaults

```
SERVORD
SO:
>ADO
SONUMBER: NOW YY MM DD
>$
DN_OR_LEN
>6215000
OPTION:
>DSCWID
SUBOPT:
>$
OPTION:
>$
COMMAND AS ENTERED:
ADO NOW YY MM DD 6215000 (DSCWID $) $
ENTER Y TO CONFORM, N TO REJECT, OR E TO EDIT
Y
```

The following example assigns DSCWID to 621-5000 with the characteristics of DSCWID type ADSICID. The AMA recording status is CONF and the default treatment is ANNC.

TR-303 Generic Interface (continued)**MAP display of SERVORD Add Option (ADO) command with overrides**

```

SERVORD
SO:
>ADO
SONUMBER: NOW YY MM DD
>$
DN_OR_LEN
>6215000
OPTION:
>DSCWID
SUBOPT:
>DTYPE
DTYPE:
>ADSICID
SUBOPT:
>DAMA
DAMA:
>CONF
SUBOPT:
>DEFTRMT
DEFTRMT:
>ANNC
SUBOPT:
>$
OPTION:
>$
COMMAND AS ENTERED:
ADO NOW YY MM DD 6215000 (DSCWID (DTYPE ADSICID)
(DAMA NONE) (DEFTRMT ANNC)$)$
ENTER Y TO CONFORM, N TO REJECT, OR E TO EDIT
Y

```

Error messages for SERVORD

The following SERVORD error messages may occur for the SMA2.

Error messages for table LENLINES (Sheet 1 of 2)

Error message	Explanation and action
Invalid ringing type in cardinfo field for a TR303 RDT.	RNGTYPE subfield has incorrect data for the type of line datafilled.
CSP is not supported by RDTLSG, RDTMPY, RDTCON, or RDTISD line cards.	Attempt to add semi-post paid service to a TR-303 RDT line.
2FR is not supported for RDTLSG, RDTCON, or RDTISD line cards.	Multiparty card code not used.

Error messages for table LENLINES (Sheet 2 of 2)

Error message	Explanation and action
4FR is not supported for RDTLSG, RDTCON, or RDTISD line cards.	Multiparty card code not used.
Only 6X19/8D09/RFT RDTLSG card can have MWL notice.	Attempt to add message waiting option with lamp.

3 Expanded Subscriber Carrier Module-100 Access (ESMA)

Understanding SMA2 translations

The entry of data in the Expanded Subscriber Carrier Module-100 Access (ESMA) requires knowledge of SMA2 plans and terminology. Another name for the ESMA is the SMA2. This chapter describes the product and provides signaling information required to understand SMA2 operation.

Introduction

To modernize current networks, operating companies replace copper with fiber at an accelerated pace. The operating companies seek reduced ownership costs, easier, more flexible networks, and increased bandwidth for advanced services. Integrated services digital networks (ISDN), residential video, and multimedia are advanced services. Operating companies require Bellcore Standard TR-TSY-000303 (TR-303) compliant interface products. These products support advanced services and enhanced operations, administration, maintenance and provisioning (OAM&P).

The TR-303 is a technical requirements standard. The TR-303 establishes guidelines for multiple vendors to have access to the digital services and operations of a central office. The TR-303 provides call processing services and OAM&P abilities. The processes and abilities are better than earlier TR-008 systems.

The SMA2

The Expanded Subscriber Carrier Module-100 Access (ESMA) is the Northern Telecom (Nortel) TR-303-compliant multi-vendor interface (MVI) solution. Another name for the ESMA is the SMA2. The SMA2 connects remote digital terminals (RDT) to the DMS SuperNode switch. The RDTs access digital services from the DMS SuperNode switch through the SMA2.

The SMA2 provides:

- multi-vendor interface to a DMS SuperNode switch
- a maximum of 28 DS-1 links for each RDT

3-2 Expanded Subscriber Carrier Module-100 Access (ESMA)

- support for a maximum of eight RDTs, or seven RDTs when equipped with an ISDN
- support for a maximum of 48 integrated channel banks (ICB). The limit for the number of ICBs is 15 if eight RDTs connect to the SMA2. The number of channel banks that can connect to an SMA2 and the number of TR-303 RDTs that connect to an SMA2 appear in the following table.

Table 3-1 Number of channel banks that can connect to an SMA2

TR-303 RDTs	Maximum channel banks
0	48
1	46
2	44
3	42
4	40
5	38
6	36
7	34
8	15

- connectivity to junctored network (JNET) or enhanced network (ENET)

The SMA2 is a common peripheral module (CPM)-based host peripheral module (PM). The SMA2 provides the interface between the DMS SuperNode switch and an RDT. The name SMA2 in this document refers to the hardware and software that provide the interface.

The name SMA system describes the SMA2 and additional elements like:

- DMS SuperNode switch software that supports the SMA2 to RDT interface, and maintenance and provisioning functions
- test and service circuits for signal processing
- RDT line test capabilities

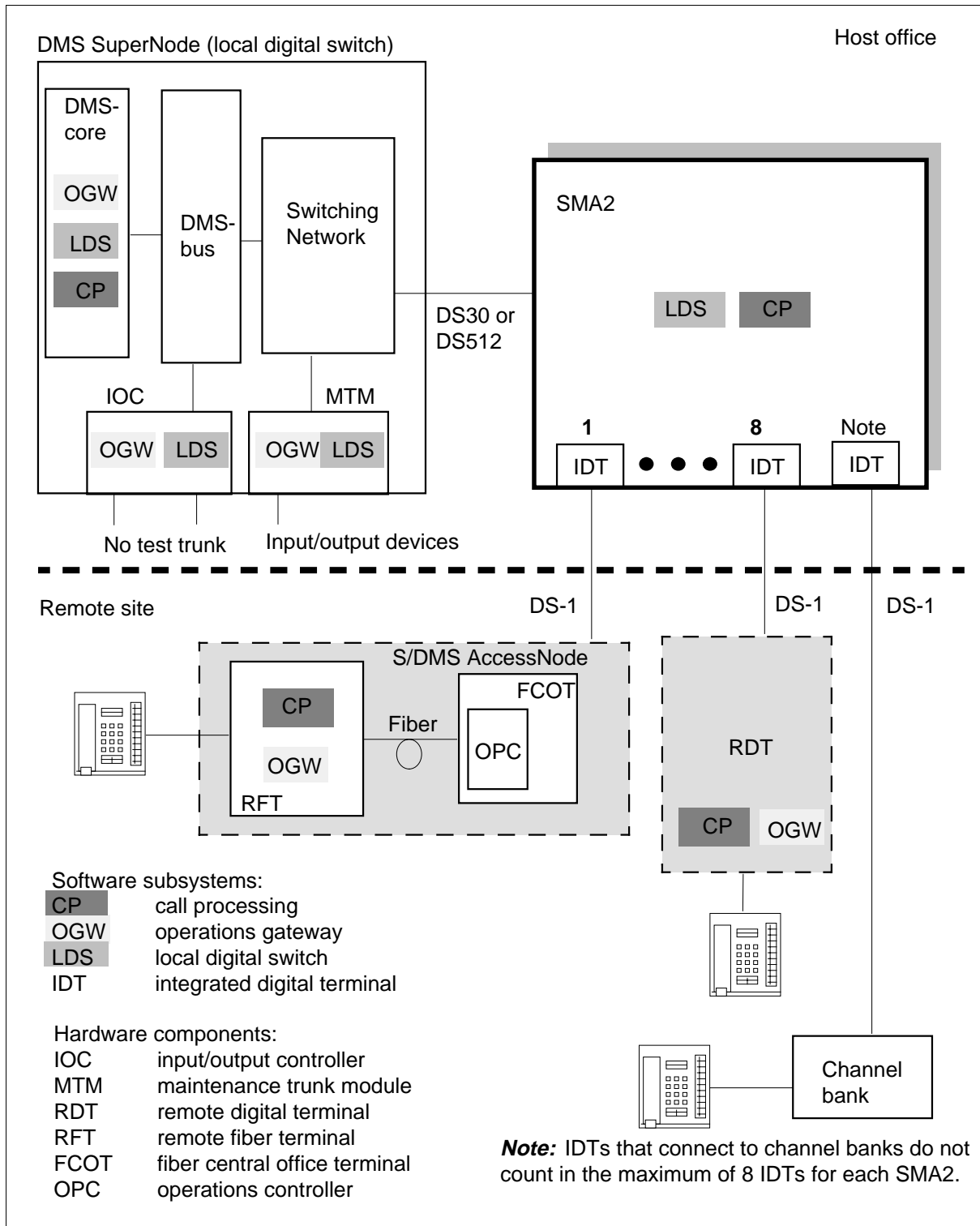
Information in this document contains the correct translations datafill of the SMA2 that supports:

- MVI RDTs
- S/DMS AccessNode
- integrated channel banks

SMA system overview

This section provides an summary of the SMA system. The hardware components and software subsystems of the SMA system appear in the following figure.

Figure 3-1 SMA system configuration



SMA system functionality

Introduction

This section addresses the following aspects of SMA system functionality:

- voice and data communications
- foreign exchange subscriber end (FXS) signaling
- call setup, call take-down, and call monitoring messages
- operations, administration, maintenance, and provisioning (OAM&P) messages
- ISDN Basic Rate Interface (BRI) signaling (functional only, the SMA system does not support stimulus signaling)
- Bellcore compliant Analog Display Services Interface (ADSI) tones and compatible data
- path protection switching
- communications protocols
- call processing
- service capabilities

Note: References to remote digital terminal (RDT) in this section apply to multi-vendor interface (MVI) access remotes and S/DMS AccessNode remotes. Another name for these remotes are remote fiber terminals (RFT). When specified references to a remote access vehicle occur, the term S/DMS AccessNode or RFT refers to the Northern Telecom next generation digital loop carrier (NGDLC), the S/DMS AccessNode.

Voice and data communications

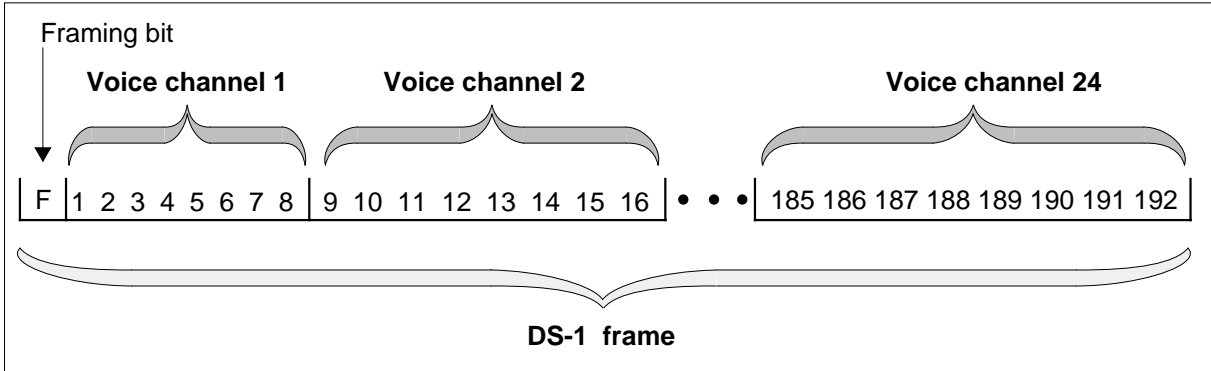
Voice and data calls transfer between the RDT and the Expanded Subscriber Carrier Module-100 Access (ESMA). Another name for the ESMA is the SMA2. These transfers occur through DS-1 links with extended superframe format (ESF) signaling.

DS-1 frame format

The SMA2 and RDT exchange information over DS-1 links. The DS-1 links operate at a rate of 1.544 Mbyte/s with a sampling frequency of 8000 frames each second.

The DS-1 frame contains 24 8-bit bytes and a framing bit for a total of 193 bits for each frame. The 8-bit bytes fit in time slots or channels for a total of 24 channels in each frame. The framing bit is before the 24 channels. These channels carry speech information, signaling information, or operations information. The format of a DS-1 frame appears in the following figure.

Figure 3-2 DS-1 frame format



The framing bit identifies the location of the first time slot in the frame. The RDT or SMA2 receives a framing bit. This bit notifies the RDT or SMA2 that the following 8 bits contain information from time slot one. Use of the framing bit occurs for frame alignment in the superframe and extended superframe alignment configurations.

Superframe format signaling

A superframe contains 12 24-channel frames. Use of framing bits occurs in superframe signaling for frame alignment and superframe alignment. The framing bit identifies the location of the first time slot in the frame. The SMA2 or channel bank receives a framing bit. The bit notifies the SMA2 or channel bank that the eight bits that follow contain information from time slot one.

Superframe alignment identifies frames that contain time-slot-associated signaling bits. In superframe alignment, the framing bits form a 12-bit pattern. One framing bit is present for each 24-channel frame. This pattern appears in the following table.

Figure 3-3 Superframe alignment pattern

Frame number	Framing bit type	Framing bit value
1	Ft	1
2	Fs	0
3	Ft	0
4	Fs	0
5	Ft	1
6	Fs	1
7	Ft	0
8	Fs	1
9	Ft	1
10	Fs	1
11	Ft	0
12	Fs	0

Framing bits in frames 1, 3, 5, 7, 9, and 11 are frame timing (Ft) bits. Framing bits in frames 2, 4, 6, 8, 10, and 12 are frame signaling (Fs) bits.

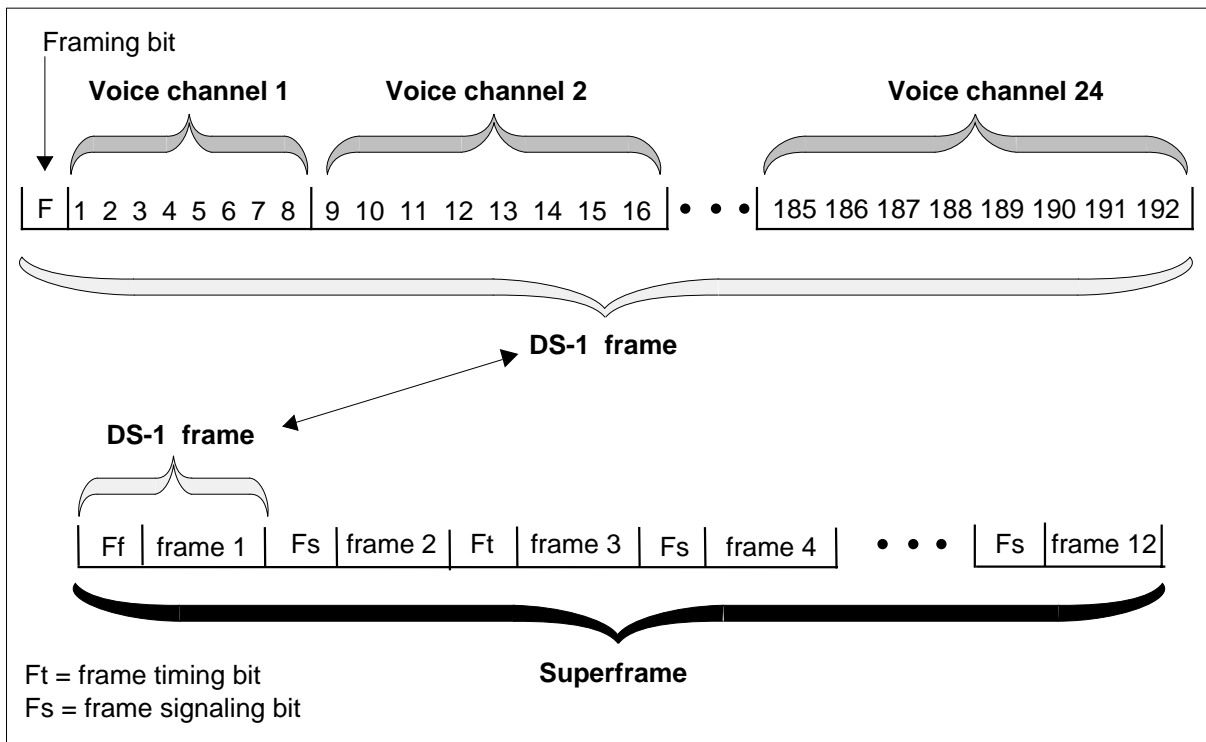
An Fs bit changes from 0 to 1 in the change from frame 4 to frame 6. This bit signals the SMA2 or the channel bank that the sixth frame follows the 1 framing bit. An Fs bit changes from 1 to 0 in the change from frame 10 to frame 12. This bit notifies the SMA2 or the channel bank that the twelfth frame follows the 0 framing bit.

Identification of the sixth and twelfth frames in a superframe is important because these frames contain time-slot-associated signaling bits. These bits are present on all 24 time slots of the sixth and twelfth frames in the least significant bit position. A speech-signal bit was in this position. The system robbed and replaced the bit with a signaling bit. The signaling bit depends on the direction the data travels.

Signaling bits in the sixth frame are called A-bits. Signaling bits in the twelfth frame are called B-bits.

The format of a DS-1 superframe appears in the following figure.

Figure 3-4 DS-1 superframe format



Extended superframe format signaling

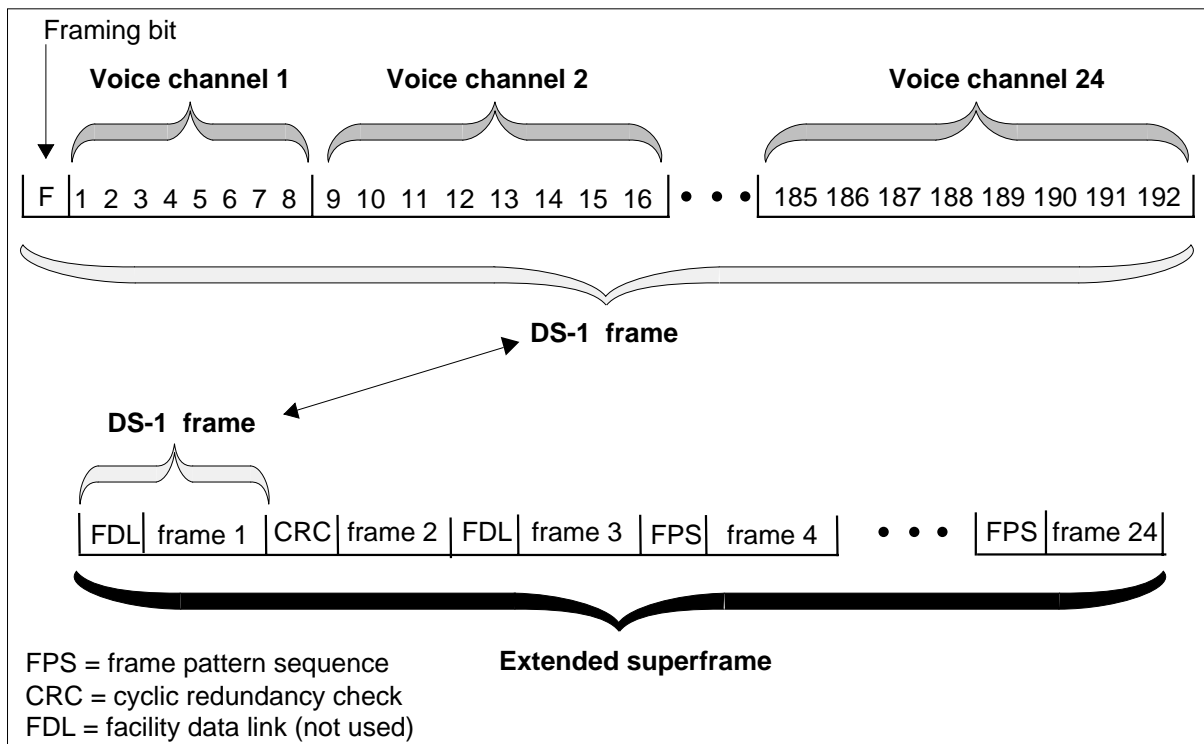
Extended superframe format (ESF) signaling monitors DS-1 link performance and maintenance functions. The ESF allows ABCD bits, instead of AB bits, to represent messages bits. This condition improves robbed bit signaling messages. Use of AB bits occurs in the superframe format.

The ESF contains 24 DS-1 frames. In ESF, the framing bits form a 24-bit pattern. One framing bit is present for each 24-channel frame. The 24-bit pattern transmits the following information:

- frame pattern sequence (FPS)—The framing bit carries an FPS value of 001010. The FPS begins at the fourth frame and occurs every fourth frame through the use of the framing bits. Together with the cyclic redundancy check (CRC), the FPS defines an in-frame condition.
- facility data link (FDL) performance—Use of this capability does not occur. The FDL 4 is a Kb/s message. The FDL begins at the first frame and occurs every other frame through the use of the framing bits. The SMA2 does not support facility protection and does not use FDL messaging bits.
- cyclic redundancy check—The CRC begins at the second frame and occurs every fourth frame through the use of the framing bits. In an extended superframe, a check of a block check field occurs six times. The CRC-6 check detects bits that emulate an FSP bit and determines if an out-of-frame condition is present.

The format of a DS-1 ESF appears in the following figure.

Figure 3-5 DS-1 ESF format



The extended superframe alignment pattern appears in the following table.

Figure 3-6 Extended superframe alignment pattern

Frame number	Framing bit type	Framing bit value
1	FDL	m
2	CRC	CB1
3	FDL	m
4	FPS	0
5	FDL	m
6	CRC	CB2
7	FDL	m
8	FPS	0
9	FDL	m
10	CRC	CB3
11	FDL	m
12	FPS	1
13	FDL	m
14	CRC	CB4
15	FDL	m
16	FPS	0
17	FDL	m
18	CRC	CB5
19	FDL	m
20	FPS	1
21	FDL	m
22	CRC	CB6
23	FDL	m
24	FPS	0

m = message bits
CB = check bits

FXS signaling for ICB

FXS signaling

For channel bank connectivity, the SMA2 supports foreign exchange subscriber end (FXS) signaling for loop and ground start lines from channel banks. The FXS signaling does not support battery changes, like battery reversal.

The FXS signaling uses AB bit signaling in superframe format or extended superframe format. For information on superframe format, see the section "Superframe format signaling" at the beginning of this chapter. For information on extended superframe format signaling see the previous section titled "Extended superframe format signaling." A description of AB bit signaling is present later in this section.

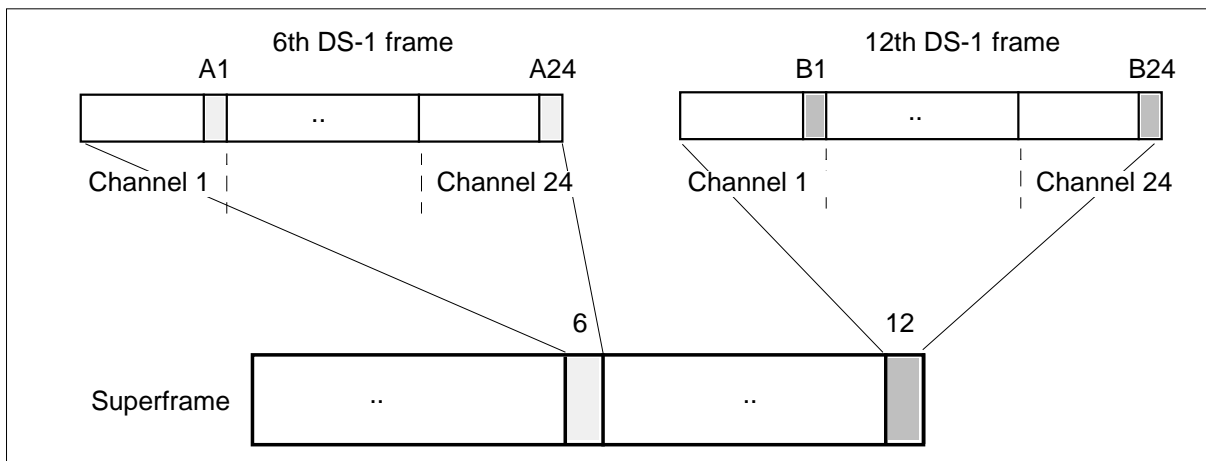
The FXS signaling supports:

- single party
- Centralized exchange (Centrex)
- custom local area signaling services (CLASS) and analog display services interface (ADSI). The system supports these services if the channel bank provides these services.

AB bit signaling

Use of the AB bit signaling is for call processing activities between the SMA2 and the channel bank. The AB bits are the bits on the superframe least significant bits of each 8-bit channel in the 6th and 12th frames. The group of A and B bits can define a maximum of four different codes in each direction. These directions are channel bank to IDT and IDT to channel bank. A diagram of AB bits extracted for time slot 1 of a DS-1 superframe appears in the following figure.

Figure 3-7 AB bits extracted from a DS-1 superframe



In the 6th and 12th frame, the 8th bit in each eight-bit word is suppressed and replaced by a signaling information bit. This signaling information bit represents the signaling and supervision state of the channel concerned. The following table shows the superframe AB signaling supported by the SMA2 to ICB configuration.

Figure 3-8 Superframe AB bit use in the SMA2 to ICB configuration

Frame number	Bit use in each channel		Signaling bit
	Data	Signaling	
1	1-8	-	A
2	1-8	-	
3	1-8	-	
4	1-8	-	
5	1-8	-	
6	1-7	8	
7	1-8	-	
8	1-8	-	
9	1-8	-	
10	1-8	-	
11	1-8	-	
12	1-7	8	B

In extended superframe signaling, the A and B signaling bits are transmitted in the 6th and 12th frames and repeated in the 18th and 24th frames. In the receive direction, the A bit is read from the 6th frame and the B bit is read from the 12th frame. The A and B signaling bits in the 18th and 24th frames are not used in the receive direction. The following table shows the extended superframe AB signaling supported by the SMA2 to ICB configuration.

Figure 3-9 Extended superframe AB bit use in the SMA2 to ICB configuration

Frame number	Bit use in each channel		Signaling bit	
	Data	Signaling	Transmit	Receive
1	1-8	-		
2	1-8	-		
3	1-8	-		
4	1-8	-		
5	1-8	-		
6	1-7	8	A	A
7	1-8	-		
8	1-8	-		
9	1-8	-		
10	1-8	-		
11	1-8	-		
12	1-7	8	B	B
13	1-8	-		
14	1-8	-		
15	1-8	-		
16	1-8	-		
17	1-8	-		
18	1-7	8	A	-
19	1-8	-		
20	1-8	-		
21	1-8	-		
22	1-8	-		
23	1-8	-		
24	1-7	8	B	-

Call setup, call take-down, and call monitoring

The type of RDT determines if call setup, call take-down, and call monitoring signals are different. The RDT can be a generic TR-303 RDT or an S/DMS AccessNode. Use of the following signaling types occurs:

- The TR-303 hybrid signaling, that generic RDTs use, contains:
 - robbed bit signaling (RBS)
 - time-slot management channel (TMC) signaling
- common signaling channel (CSC) signaling that the S/DMS AccessNode uses

A description of these two signaling types appear in the sections that follow.

TR-303 hybrid signaling

The TR-303 hybrid signaling uses the following two types of signaling:

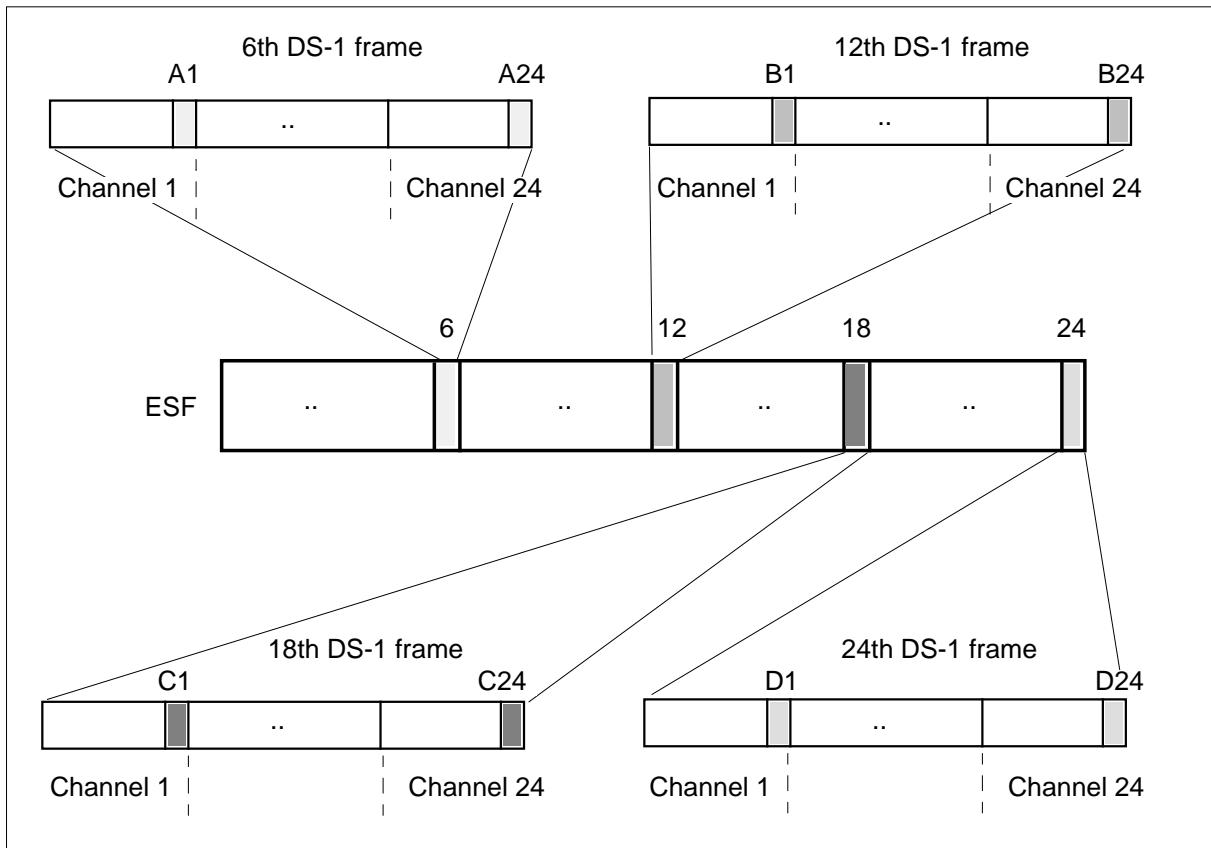
- in-band signaling
- out-of-band signaling

Integrated digital loop carrier (IDLC) call processing requires TR-303 hybrid signaling for support.

Robbed bit signaling

Use of robbed ABCD bit signaling occurs for call supervision, ringing, and dial pulse (DP) digit transmission between the IDT and the RDT. This condition occurs over the assigned time slot. Another name for the robbed ABCD bit signaling is robbed bit signaling (RBS). The ABCD bits are the bits extracted from the ESF least significant bits. The ABCD bits are from each 8-bit channel in the 6th, 12th, 18th, and 24th frames. The group of A, B, C, and D bits can define a maximum of 16 codes in each direction. These directions are RDT to IDT and IDT to RDT. The following figure illustrates four ABCD bits extracted for time slot 1 of a DS-1 ESF. In-band (ABCD) signaling occurs channel-by-channel.

Figure 3-10 ABCD bits extracted from a DS-1 ESF



Use of the ABCD bits occurs to exchange call supervisory information between the IDT and the RDT. The IDT uses TMC to set up a clear time slot connection at the RDT.

The ABCD signaling provides the following functions:

- scanning for hook state changes

The ABCD signaling scans hook state changes. The signaling processor for answer, disconnect, or flash signals from customer lines filters hook state changes.

- IDT ringing control to send ringing patterns to the RDT

The IDT is responsible for ringing cadencing and scheduling and the RDT is responsible for ringing to customer lines.

- service to IDT call processing for loop signaling and supervision

Provides the ability to send and receive ABCD codes for loop signaling and supervision.

- service to IDT coin call processing to perform coin control functions and tests for coin lines
Coin control functions are coin collect and coin return. Coin tests are coin presence and coin partial presence.
- service to IDT call processing for automatic numbering identification (ANI) test for two-party lines
This test to identifies the party of a two-party line that originates the call, for billing purposes.
- dial pulse (DP) digit collection
When DP digits are dialed, the system generates hook status transients on the line. The hook changes indicate the dialing of a valid digit.
- DP digit outpulsing
The DP digit outpulsing provides digit outpulsing to customer premises equipment.

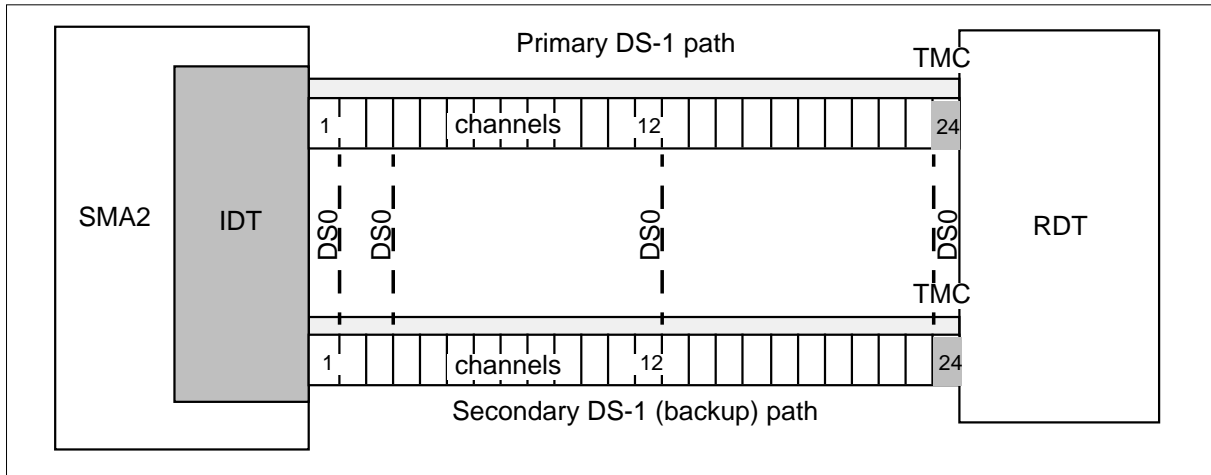
Time-slot management channel signaling

The other name for the time-slot management channel (TMC) signaling, is out-of-band signaling. The TMC signaling is a message-oriented signaling type. The TMC signaling signals the connection and disconnection of timeslots. These connections occur between the IDT and RDT. The TMC signaling sets up and takes down calls in an MVI RDT. These call processing signals:

- transmit over channel 24 of a DS-1 link
- use Q.931 message protocol
- are path protected
- can contain a maximum of 32 octets. An octet is 1 byte that contains 8 bits.

Signaling between an SMA2 and an RDT over a DS-1 link with the TMC channel transmitted over channel 24 appears in the following figure.

Figure 3-11 SMA2 to RDT connectivity



Common signaling channel signaling

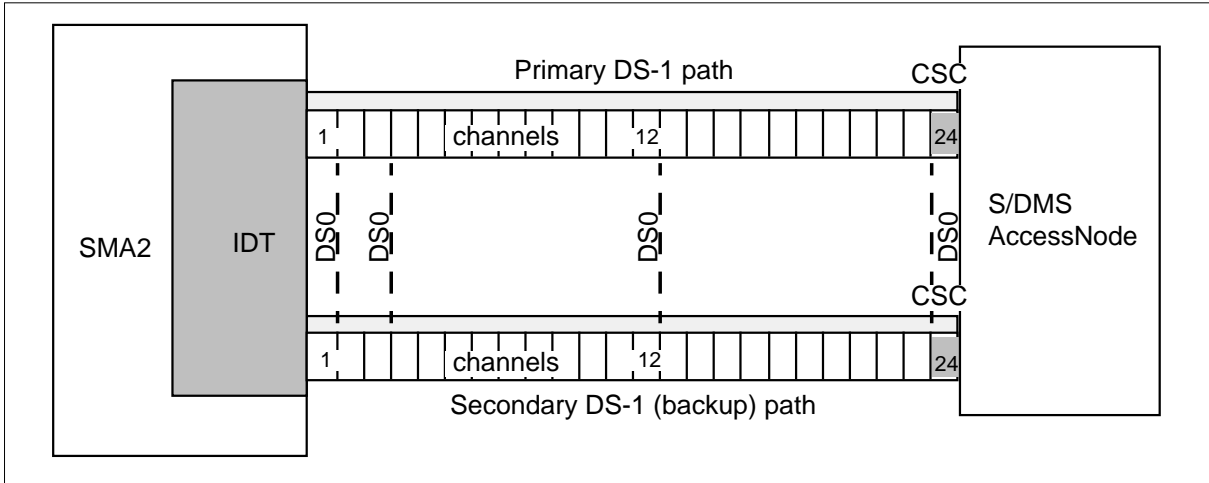
The CSC is a message-oriented signaling type that sets up, monitors, and takes down calls in the S/DMS AccessNode. These call processing signals:

- transmit over channel 24 of a DS-1 link
- use Q.931 message protocol
- are path protected
- can contain a maximum of 52 octets

Not like TR-303 hybrid signaling (robbed bit signaling), all CSC call processing signals transmit over a dedicated channel. Channel 24 of a DS-1 frame is the dedicated CSC channel. Eight bits of each message, called an octet, transmit with each DS-1 frame.

Signaling between an SMA2 and an S/DMS AccessNode occurs over a DS-1 link. The CSC channel transmits over channel 24. This event appears in the following figure.

Figure 3-12 SMA2 to S/DMS AccessNode connectivity



Operation, administration, maintenance, and provisioning (OAM&P)

Operations, administration, maintenance, and provisioning messages transmit for an:

- SMA2 and a generic TR-303 RDT
- S/DMS AccessNode over embedded operations channel (EOC)

This section describes the EOC message signaling.

EOC message signaling

The EOC is a message-oriented operations channel that exchanges OAM&P information between the RDT and the IDT. These operations messages:

- transmit over channel 12 of a DS-1 link
- use EOC communication protocol
- use ASN.1 basic encoding rules
- are path protected

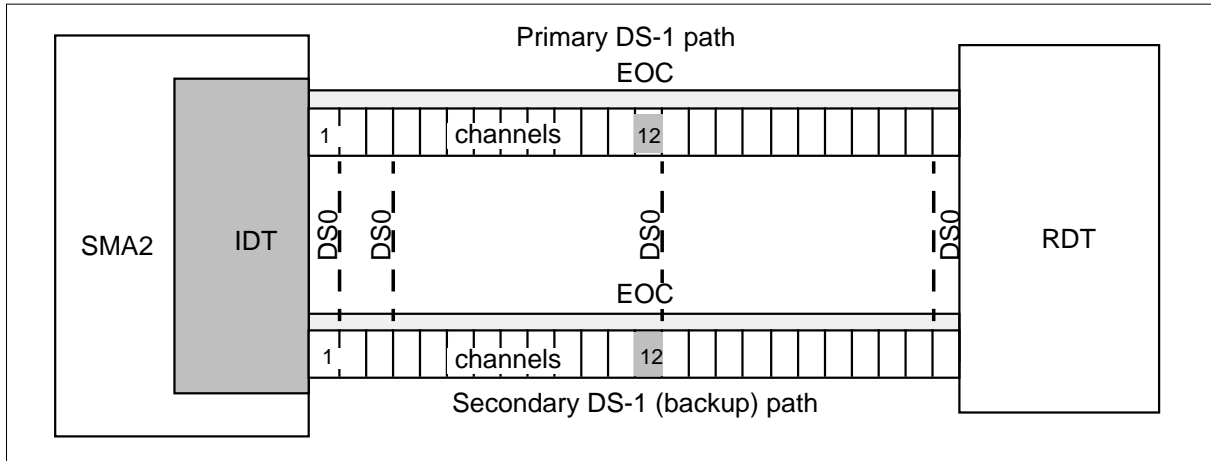
The SMA2 communicates EOC messages between the IDT and the RDT to:

- initialize and maintain object-oriented static data at the RDT
- provide line test position (LTP) capabilities to the RDT
- permit the RDT to connect to external test systems

The RDT uses EOC messages to inform the SMA2 of RDT activities through logs and remote telemetry.

Signaling between an SMA2 and an RDT over a DS-1 link with the EOC channel transmitted over channel 12 appears in the following figure.

Figure 3-13 SMA2 to RDT signaling over the EOC channel



The following DMS applications use EOC message signaling:

- the DMS line provisioning-which controls the datafill of subscriber services. Line provisioning refers to hardware provisioning and to service provisioning.
- the DMS line maintenance and automatic line testing (ALT)-provides for the control and monitoring of subscriber line states from the MAP terminal. This feature allows diagnostic tests of the lines.
- logs and alarms-that allow the report of alarms and events to the DMS MAP terminal and operations support system that connects to the RDT.
- node maintenance-which provides for the control of voice and data channels between the DMS CM and peripheral devices. These devices include the SMA and the RDT

ISDN BRI signaling

The other common name for the integrated services digital network basic rate interface (ISDN BRI) is 2B+D. ISDN BRI contains two 64-kbit B-channels for voice and data and a 16-kbit D-channel for signaling and packet data. The two types of ISDN BRI signaling are functional and stimulus.

Software built in the set of the functional BRI terminal supports functional BRI signaling. The Q.931 protocol, with the signaling control protocol, sends call control messages between the terminal and the network. The SMA2 does not support Stimulus BRI signaling.

The ISDN BRI contains two B-channels for voice and packet data and a D-channel for signaling. The TMC messages continuously assign the B-channels for voice and data use. The system nails up D-channel at provisioning time. The D-channel is a permanently assigned network connection. Messages over the EOC controls assignment of the D-channel.

National ISDN-2/3 BRI Phase I feature

The National ISDN-2/3 BRI Phase I feature increases the operational versatility of BRI line interface configurations. This feature expands the BRI service options available to end users. Access to the enhanced ISDN abilities this section describes, requires the software optionality control (SOC) NI000050 in NA007.

- Two B-channel access-This ability allows terminals that support voiceband information (VI) or circuit mode data (CMD) or both, to access the B-side channels at the same time. The terminal can access the B-side channels with one terminal endpoint identifier. This ability applies to fully initializing terminals (FIT) and non-initializing terminals (NIT). Provisioning controls the number of B-channels a terminal can access.
- Support for non-initializing terminals (NIT)-This ability supports one non-initializing terminal on a BRI interface that has the default logical terminal. An NIT is class of BRI terminal that does not initialize Layer 3. Because of this condition, the NIT does not require a service profile identifier (SPID). An SPID is an identification number that a terminal in the initialization process uses.
- Assignment of fixed feature keys to the default logical terminal for NITs-This ability allows the assignment of the following features to the NIT: call forwarding, message waiting, conference calling, call transfer, and call drop. The NIT can access these features with dial-access procedures or feature key management procedures.

The National ISDN-2/3 BRI Phase I feature introduces the following interactions:

- This feature changes how additional call offering (ACO) operates for terminals that have the access privilege entered for two B-channel access. The terminal can have a call active and one B-channel free when a termination occurs. When this condition occurs, the terminating SETUP contains the channel identifier information element (CID IE) encoded to the value of the free B-channel. For terminals without the two B-channel access privilege, this message has the CID IE encoded to no-channel.
- When flexible calling is active on a 2B FIT/NIT conference controller, the system offers all VI terminations to the terminal. The encoding of the CID IE is to no channel.

Bellcore compliant ADSI tones and compatible voiceband data

When the SMA2 has an NTMX76CA message and channel supervision messaging (CSM) card, the system generates alerting tones. These tones indicate the SMA2 supports the Spontaneous Call Waiting Identification (SCWID) or Deluxe SCWID (DSCWID) feature. A line with the SCWID or DSCWID option can have a call established and a second call can attempt to terminate to that line. When this condition occurs, the SMA2 generates one of two types of alarm signals or tones:

- A subscriber alerting signal (SAS), that the subscriber recognizes as the call waiting tone.
- A SAS followed by a customer premises equipment (CPE) alert signal (CAS)—The CAS alerts the CPE of incoming data. The SAS followed by a CAS triggers an ADSI compatible CPE to display the SCWID/DSCWID options. The CAS tone allows the CPE to receive caller identification (CID) data.

The SCWID/DSCWID CPE generates an acknowledge (ACK) tone to indicate the CPE can receive SCWID data. If the CPE is ADSI compatible, the CPE returns a DTMF A ACK signal in response to the CAS. If the CPE is a SCWID CPE, the CPE returns a DTMF D ACK signal in response to the CAS.

For the DSCWID option only, when the CPE sends alerting tones, the subscriber can control the disposition of the incoming call. The subscriber uses the CPE softkeys if the CPE is ADSI. If the CPE is a SCWID or 2500 set, the subscriber uses hard-coded keys.

A T-tone timer sets the maximum amount of time allowed between the process to send a flash and the DTMF digit on an ADSI set. After the SMA2 receives a flash signal from the ADSI compatible CPE of the customer, the SMA2 starts a T-tone timer. The value of T-tone is 600 ms. The speech path is muted during this 600 ms interval. The T-tone timer is the first option used of a SCWID/DSCWID call. The CPE type does not affect whether or not the SMA2 uses a T-tone timer. Any following SCWID/DSCWID options on an ADSI set use the T-tone timer.

Any following DSCWID options on a SCWID or 2500 set use a different timer (T-flash). DSCWID options use T-flash after the subscriber answers a call with a SCWID or 2500 set. T-flash provides operating company personnel time to select an option after a flash. This timer is needed because a subscriber does not have enough time to flash and dial a DTMF digit in 600 ms. T-flash is an operating company controlled timer that is set from 1 to 8 s. The default value is 1.5 s. The SMA2 starts the T-flash timer if the NON-ADSI field is set to Y and the SMA2 receives a flash signal from the SCWID or 2500 set during

the held or conference call state. If the SMA2 cannot attach a UTR before 400 ms, the RETURN option is applied.

Note: For Bellcore TR-416 compliance, the SMA2 must provide options if the SMA2 detects a flash and cannot attach a UTR. The SMA2 accepts this requirement and sends a flash to CC if the SMA2 cannot attach a UTR in 400 ms.

ADSI interactions

The following ADSI interactions apply:

- A warm SWACT during the download or transmission of softkey data to the CPE does not allow the CPE to receive data. Failure of the CPE to receive all of the data results in an ADSI call that is not stable.
- After a warm SWACT, transmissions to the CPE set that follow cause the active ADSI session to drop.
- The CMR circuit card can have a busy return to service. This event occurs when an active application session causes an ADSI call that is not stable.
- A busy of the CMR circuit card on the active unit of the XPM does not allow CLASS services. These CLASS services use the CMR card circuit to function.

ADSI restriction

The following ADSI restrictions apply:

- A successful ADSI session requires an ADSI compatible CPE.
- Only ten ADSI sessions can be active for each CMR circuit card.

ADSI hardware requirements

Hardware requirements to support ADSI ability are:

- an NT6X78AB CMR card transmits softkey and display information to the CPE
- an NTMX76CA message and CSM card

Path protection switching

Path protection switching provides protection for the EOC and TMC or CSC message and signaling channels. The SMA2 supports one-for-one path protection switching for these messaging and signaling channels. Path protection switching controls the switching of activity. The activity switch is from the active EOC and CSC or TMC to the backup EOC and CSC or TMC. Path protection switching provides end-to-end protection against failures of message processing hardware in the SMA2 and the RDT.

Initiation of path protection switching can be automatic or manual. The SMA2 or the RDT can initiate automatic path protection switching when detection of a fault occurs. For maintenance purposes, manual initiation of path protection switching can occur through the integrated digital terminal (IDT) level of the MAP terminal.

The following terms associate with protection switching:

- path—a TMC, CSC, or EOC message channel
- active path—the path or channel in the active state. The active path carries TMC, CSC or EOC messages, and messages for protection switching.
- standby path—the path in the standby state. The standby path carries only messages that allow the path to become the active channel.
- protection switch—occurs when the active path changes state to standby, and the standby changes state to the active path.

The following rules for protection switching apply:

- The IDT or RDT must be able to detect a failure and initiate a protection switch.
- A failure can occur on a channel. Protection switching occurs. A switch back to the original active or inactive configuration does not occur when the cause of the failure clears.
- When possible, a standby path remains in multiple-frame operation.

SMA2 to generic RDT path protection switching

For every IDT to RDT connection a dedicated TMC and EOC path is present on two links. One EOC and TMC messaging path can be active on the two links. The inactive EOC and TMC messaging paths are for backup. An EOC message channel can be active on one link when the TMC message path is active on the other link. The EOC and TMC can be active on the same link.

The use of path protection switching depends the configuration of the SMA2 and the datafill of the associated tables. The first link assignment in table RDTINV, field LINKTAB is the primary link that carries TMC and EOC messaging. The datafill in field RDTPLNK defines the secondary link that carries TMC and EOC messaging. The secondary link be as any value from 2-28 at the RDT.

The figure DS-1 control channels illustrates TMC and EOC path protection.

SMA2 to S/DMS AccessNode path protection switching

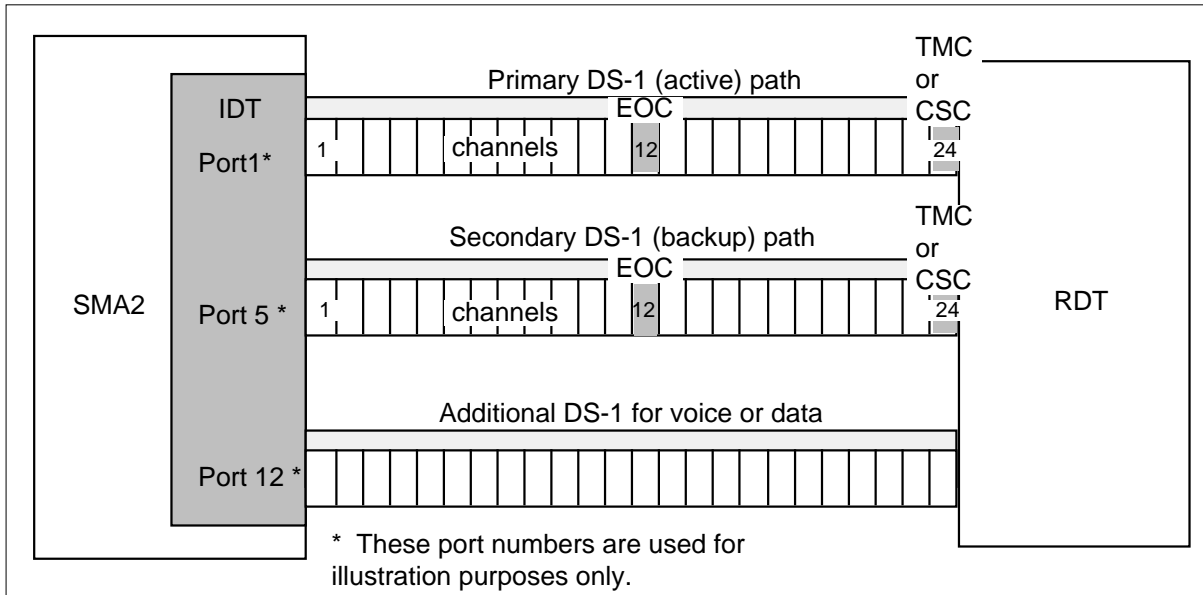
For every IDT to RFT connection a dedicated CSC and EOC is present on two links. One EOC and CSC messaging path can be active on the two links. The inactive EOC and CSC messaging paths are for backup. An EOC message

path can be active on one link when the CSC message path is active on the other link. The EOC and CSC can be active on the same link.

The use of path protection switching depends on the configuration of the SMA2 and the datafill in the associated tables. The first two link assignments in table RDTINV, field LINKTAB are the primary and secondary links. These links carry CSC and EOC messaging.

The TMC or CSC and EOC path protection appears in the following diagram.

Figure 3-14 DS-1 control channels



Manual path protection switching control

From the MAP terminal, operating company personnel can perform the following actions to control path protection switching:

- initiate a protection switch for the EOC and the CSC or TMC channel
- initiate a forced protection switch for the TMC, CSC, or the EOC channel
- inhibit the activation of a standby EOC, TMC, or CSC path
- activate a standby EOC, TMC, or CSC

Automatic path protection switching

The DS-1 links between the SMA2 and a generic RDT contain primary and secondary TMCs and EOCs. The DS-1 links between the SMA2 and the S/DMS AccessNode contain primary and secondary CSCs and EOCs. If an active CSC, TMC, or EOC fails, an automatic switch to the protection channel occurs.

A protection switch occurs on the CSC, TMC, or EOC under the following conditions:

- failures detected from Q.921 protocol. For example, failure to maintain multiple-frame operation when the message frame retransmissions N200 LAPD counter exceeds the limit.
- switch message is received from the computing module through manual intervention
- The RDT sends switch message

Manual and automatic protection switching restrictions

The following limits apply to manual and automatic protection switching:

- If you inhibit activation of a path and that path is active, you do not cause a protection switch.
- When you inhibit a path, an automatic or manual switch cannot occur to the path.
- When you inhibit a path, you cannot initiate a forced switch to the path.

Communication protocols

The RDT and RFT communicate with the DMS SuperNode over DS-1 links that terminate on the SMA2. The following protocols provide subscriber services from an RDT and support communication between the SMA2 and the RDT:

- Q.921 CCITT link access procedure on the D-channel (LAPD)
- Q.931 CCITT Digital Network Access
- EOC communication protocol
- DS30 protocol

Q.921 CCITT LAPD protocol

The Q.921 LAPD protocol:

- establishes data link communications between an integrated digital terminal (IDT) and an RDT
- transmits information a higher layer protocol sends
- receive information for delivery to a higher layer protocol

Use of the Q.921 protocol occurs for the transmission of the following messages:

- time-slot management channel (TMC) messages for RDTs
- common signal channel (CSC) messages for RFTs
- embedded operations channel (EOC) messages

The user can configure the Q.921 protocol parameters through table RDTINV. If adjustment of the LAPD parameters must occur, the user must change the two parameters on both ends (RDT and DMS). Changes to the two parameters must occur together. The user-configurable LAPD parameters in table RDTINV appear in the following table.

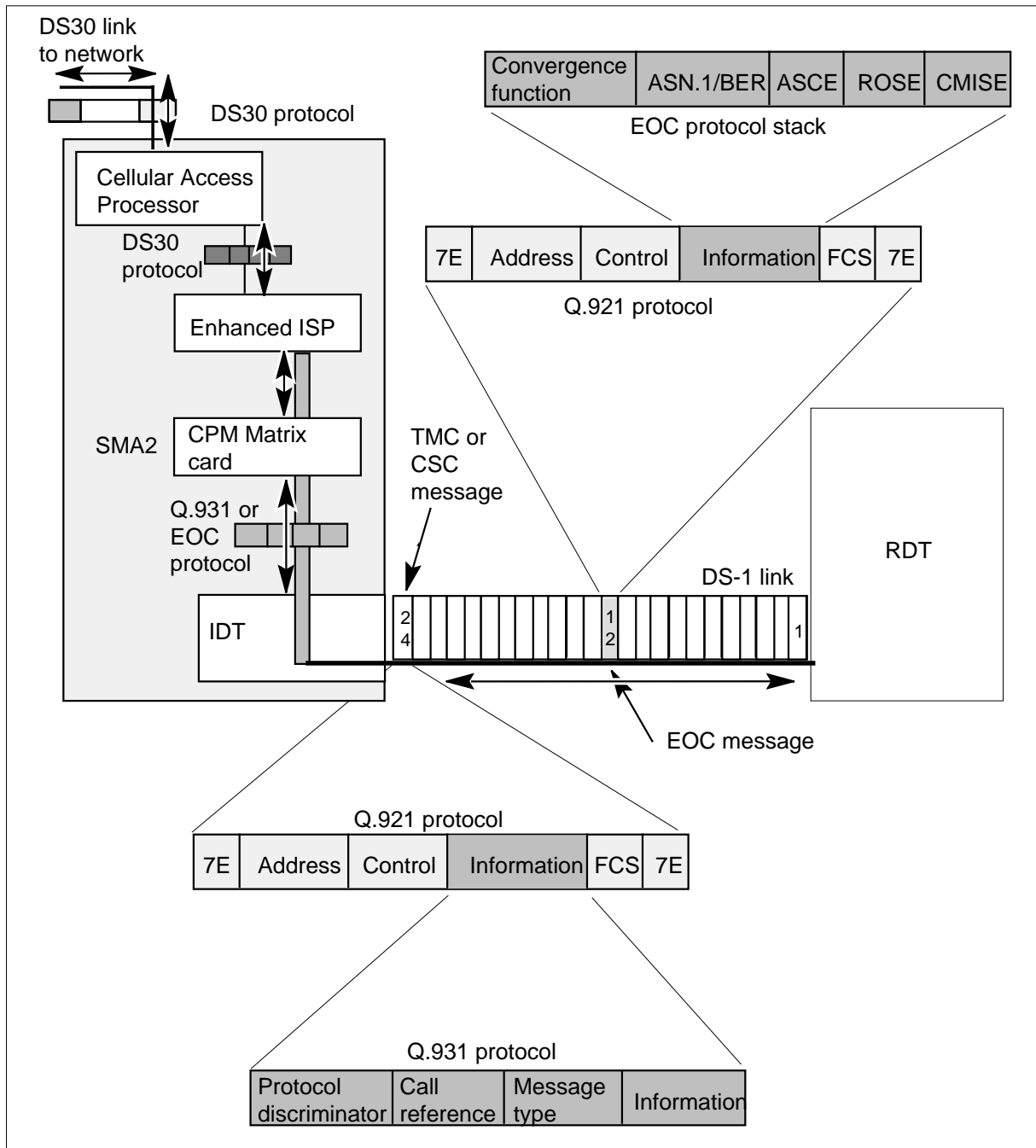
Table 3-2 Table RDTINV LAPD parameters

Parameter	Description
Maximum number of not acknowledged frames (K)	The maximum number of remaining not acknowledged message frames permitted travels between the IDT and the RDT. This parameter adjusts the size of the LAPD window.
Maximum number of retransmissions (N200)	The maximum number of message frame retransmissions allowed.
Maximum number of octets in one frame (N201)	The maximum number of octets allowed in the information field of a message frame.
Maximum time to wait for acknowledgement for one frame (T200)	The maximum length of time in milliseconds (ms) a data link layer entity waits for acknowledgement (time-out) of a transmitted message frame.
Period that there is no activity on data link (T203)	The maximum time in seconds allowed without an exchange of message frames.

Q.931 CCITT protocol

Use of the Q.931 protocol occurs to communicate call setup, call take-down, and call monitoring information between the integrated digital terminal (IDT) on the SMA2 and the RDT or the RFT. The SMA2 must translate the Q.931 generic-based signaling messages that the RDT sends to a message format the host can understand. The reversed in order can occur. The signal flow from the RDT through the SMA2 appears in the following table.

Figure 3-15 Message channel routing in the SMA2



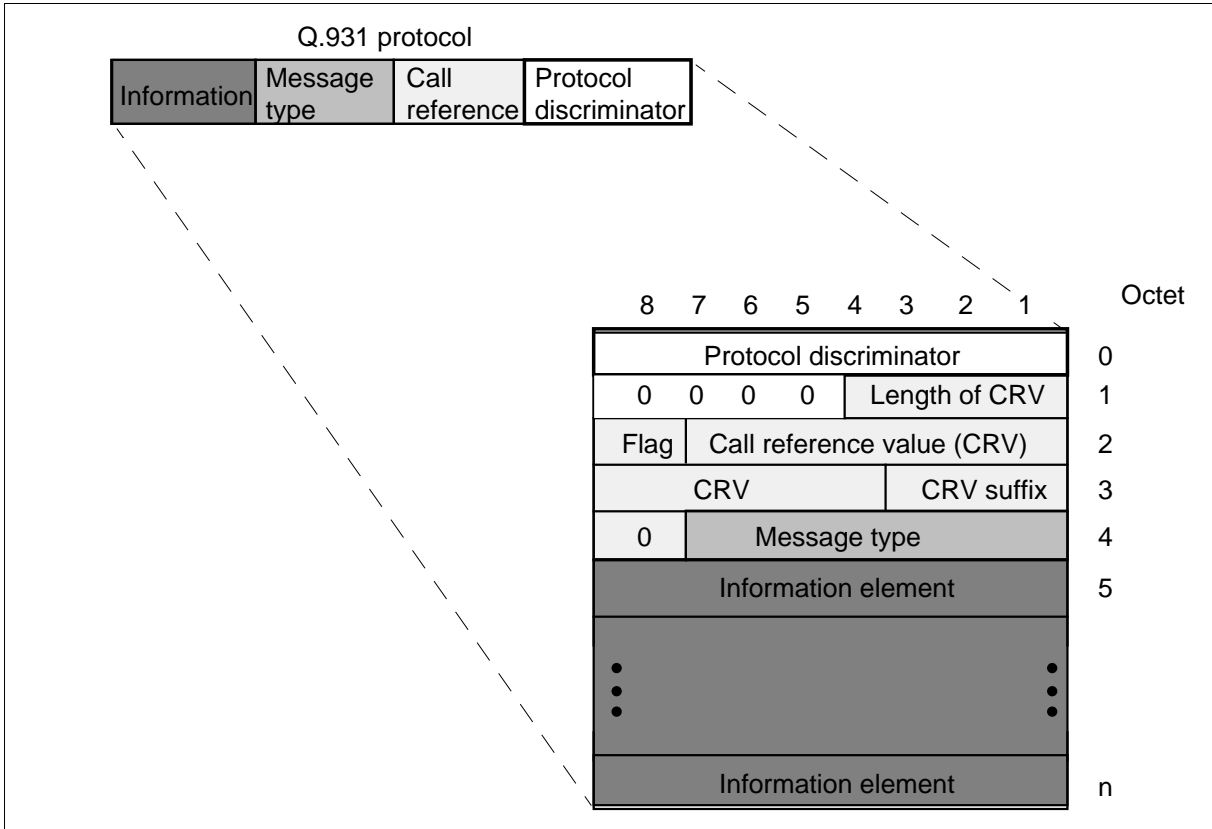
Q.931 protocol message structure

The Q.931 protocol message composition is structured. Each message contains the following components in this order:

- protocol discriminator
- call reference
- message type
- information elements

For some messages, the information element is optional. The following figure illustrates Q.931 message structure.

Figure 3-16 Q.931 protocol message structure



Protocol discriminator

The protocol discriminator is the first part of any message. The protocol discriminator identifies the type of message. The following bit sequence identifies a Q.931 protocol message: 01001111.

Call reference

The call reference is the second part of any message. The call reference identifies the line termination where the message applies. For ISDN, the call reference identifies the basic rate access (BRA) B-channel termination.

Call reference length value remains at two octets to allow 4095 line terminations.

The call reference flag identifies the message originator. The message originator sets this flag to 0. The destination side sets this flag to 1.

The call reference value, bits 1 through 7 of octet two and bits 4 through 8 of octet three, identifies the line termination.

The call reference suffix supports ISDN BRA line terminations. A suffix of 000 indicates a line termination of one channel. A suffix of 001 indicates a line termination associated with a B1 channel. A suffix of 010 indicates a line termination associated with a B2 channel.

Message type

The message type is the third part of any message. The message type identifies the type of Q.931 protocol message that follows. Each message has a different bit assignment.

Messages for time slot assignment are in two groups. These groups are messages for call establishment and messages for call take-down or disestablishment.

The Q.931 protocol message types and identifiers appear in the following table. The Q.931 protocol message types appear with the different message type identifiers. If use of the message occurs in the TMC or CSC message, this information appears in the following list:

Table 3-3 Q.931 protocol message types and identifiers (Sheet 1 of 2)

Message type	Unique identifier	Bit sequence	Applicability
Establishment message	Call proceeding	00000010	TMC and CSC
	Alerting	00000001	CSC
	Setup	00000101	CSC
	Setup acknowledge	00001101	CSC
Disestablishment messages	Disconnect	01000101	TMC and CSC
	Release	01001101	TMC and CSC
	Release complete	01011010	TMC and CSC

Table 3-3 Q.931 protocol message types and identifiers (Sheet 2 of 2)

Message type	Unique identifier	Bit sequence	Applicability
Messages for signaling	Connect	00000111	TMC and CSC
	Information	01111011	TMC and CSC
	Notify	01101110	CSC
Messages for management	Status	01110101	TMC and CSC
	Status enquiry	01110101	TMC and CSC
Q.931 messages used by ISDN	Setup	00000101	TMC and CSC
	Connect	00000111	TMC and CSC
	Status	01110101	TMC and CSC
	Audit		TMC and CSC
	Disconnect	01000101	TMC and CSC
	Release	01001101	TMC and CSC
	Release complete	01011010	TMC and CSC

Information element

The information element is the final part of a Q.931 message. The information element can be optional.

Each information element is structured. Each information element structure is different. The structural element that each information element has in common is the information element identifier.

The names and functions of Q.931 message information elements that apply to TMC and CSC appear in the following table:

Table 3-4 Q.931 message information element names and functions (Sheet 1 of 3)

Message element name	Function	Applicability
Bearer capability	Indicates information transfer capability, mode, and rate	TMC and CSC
Call state	Indicates the following RDT or IDT call states: <ul style="list-style-type: none"> • null • call initiated • call present • connect request • call active • disconnect indication • release request • permanent signal 	TMC and CSC
Cause	Indicates reason for specified messages and provides diagnostic information	TMC and CSC
Channel identification	Identifies a time slot within the interface controlled by the Q.931 message	TMC and CSC
Keypad facility	Conveys signaling inputs to the user terminal that normally addresses information	CSC See note
<p>Note: The information elements that apply only to CSC convey additional call processing information. This information is necessary to monitor a call or to set up calls that are not POTS calls.</p>		

Table 3-4 Q.931 message information element names and functions (Sheet 2 of 3)

Message element name	Function	Applicability
Notification indicator	Conveys the following line termination signaling information: <ul style="list-style-type: none"> • timed battery reversal • reverse battery • normal battery • negative loop mode • ground start mode • positive loop mode • timed negative coin check • timed positive coin check • timed negative coin control • timed positive coin control • coin ground • tip party ground • ring party • activate/deactivate message waiting lamp (Meridian Digital Centrex [MDC] 500/2500 sets only) 	CSC See note
<p>Note: The information elements that apply only to CSC convey additional call processing information. This information is necessary to monitor a call or to set up calls that are not POTS calls.</p>		

Table 3-4 Q.931 message information element names and functions (Sheet 3 of 3)

Message element name	Function	Applicability
Signal	Conveys the following alerting information: <ul style="list-style-type: none"> • negative R ringing (POTS) • reminder ring • distinctive pattern A • distinctive pattern B • distinctive pattern C • distinctive pattern D • distinctive pattern E • distinctive pattern F • alerting off • loop reverse battery alerting • silent alerting (ISDN BRA) 	CSC See note
Switch hook	Indicates when a customer has gone on-hook, and when there is a change in on-hook or off-hook status	CSC See note
<p>Note: The information elements that apply only to CSC convey additional call processing information. This information is necessary to monitor a call or to set up calls that are not POTS calls.</p>		

Q.931 message descriptions

A description of each of the Q.931 messages appears in the following table. The table has a list of the information elements that each message contains and the applicability by message type.

Table 3-5 Q.931 message descriptions (Sheet 1 of 3)

Q.931 message	Description	Information element	Applicability
Alerting	The RDT sends this message to the IDT to indicate the start of an alert to the called party. This message indicates the connection of the time switch.	This message contains the channel identification information element. Channel identification applies if the alert message is a first response to a setup message.	CSC
Call proceeding	The IDT sends this message to the RDT to respond to a setup message for a loop reverse battery signaling call.	This message contains the channel identification information element.	TMC and CSC
Connect	The RDT sends this message to the IDT to indicate the connection of a time slot. The message indicates that the terminating party answered the call. The IDT sends this message to the RDT at the end of digit collection. This message indicates the receipt of a complete network address. The RDT sends this message to respond to a setup message with an alerting OFF pattern in the signal element.	This action occurs for ISDN. The message contains the channel identification information element.	TMC and CSC
Disconnect	The IDT sends this message to the RDT when the IDT determines it is necessary to clear the call. The RDT sends this message to the IDT to report when the subscriber goes on-hook.	This message contains the cause information element.	TMC and CSC
Information	The RDT or the IDT sends this message to indicate signaling information, addressing information, and/or feature activation.	This message contains information elements: keypad facility, switch hook, and signal.	TMC and CSC

Table 3-5 Q.931 message descriptions (Sheet 2 of 3)

Q.931 message	Description	Information element	Applicability
Notify	The RDT or the IDT sends this message to indicate signaling events on the customer line, for example, battery reversal. The RDT and the IDT use this message to perform coin functions.	This message contains the notification indicator information element.	CSC
Release Release complete	The RDT or the IDT sends this message to indicate the equipment that sends the message disconnected the time slot. This message indicates that the equipment intends to release all resources associated with the call. The equipment that receives the message must release the time switch connection and all resources associated with the call.	These messages contain the cause information element.	TMC and CSC
Release resources	The IDT sends this message to the RDT to request that the receiver of the message break the time switch connection. This message requests that the receiver release resources associated with the call.	This message contains the cause and signal information elements.	CSC
Setup	The RDT or the IDT sends this message to initiate the start of a call. From the IDT, this message contains the channel identification, keypad facility, and signal information elements.	From the RDT, this message contains the bearer ability information element.	TMC
Setup acknowledge	The IDT sends this message to respond to a setup message. The message indicates a connection occurred through the enhanced time switch for the call. The message notifies the RDT of the port and channel that the call uses.	This message contains the channel identification and notification indicator information elements.	CSC

Table 3-5 Q.931 message descriptions (Sheet 3 of 3)

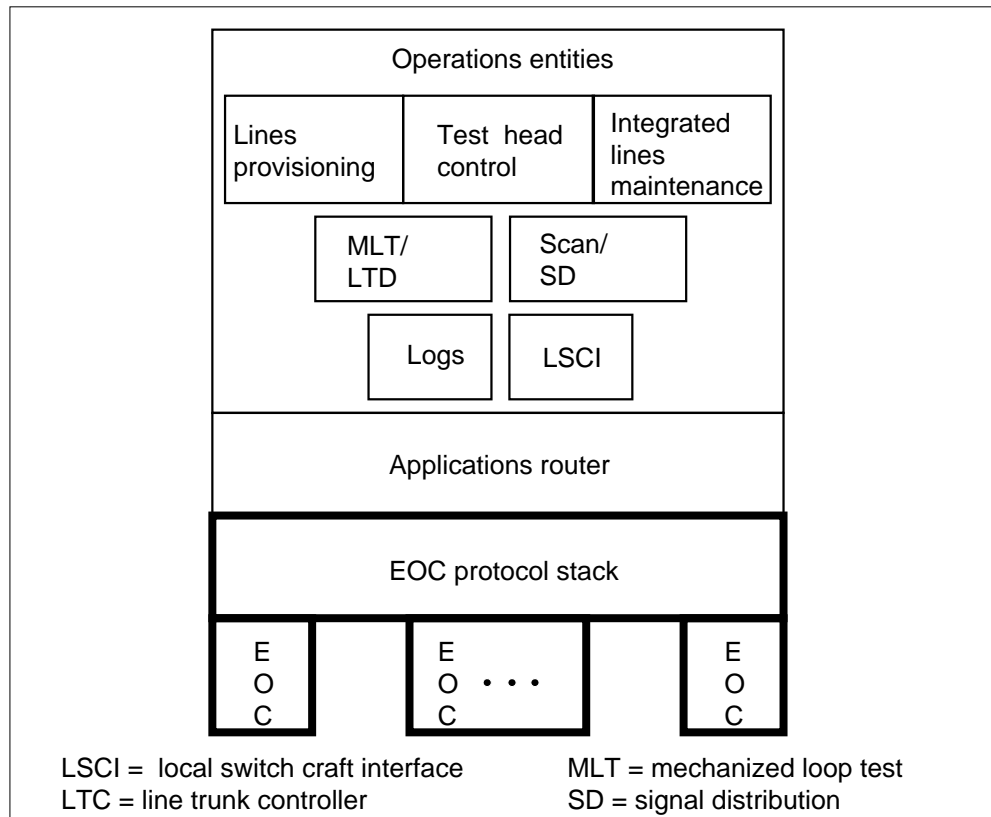
Q.931 message	Description	Information element	Applicability
Status	The IDT or the RDT sends this message during the call, when an unexpected message is received. The IDT or RDT sends the message when an unexpected message reports other conditions of the call.	This message contains the cause and call state information elements.	TMC and CSC
Status enquiry	The IDT or the RDT sends this message to solicit a status message from the receiver.	This message does not contain information elements.	TMC and CSC

EOC communication protocol

The RDT and the SMA2 communicate through the EOC communications channel. This communication occurs over a dedicated DS0 with the Q.921 LAPD protocol on ISDN D-channels. Operations messages transmit between the DMS SuperNode switch and the RDT. The EOC communications channel uses the operations gateway (OGW) software. The EOC uses the software to provide the protocol translation and routing abilities needed to connect RDTs to operations entities. The OGW contains the following three elements:

- EOC protocol stack—provides the communications function
- applications router—provides the communications function
- operation entities—the users of this communication function

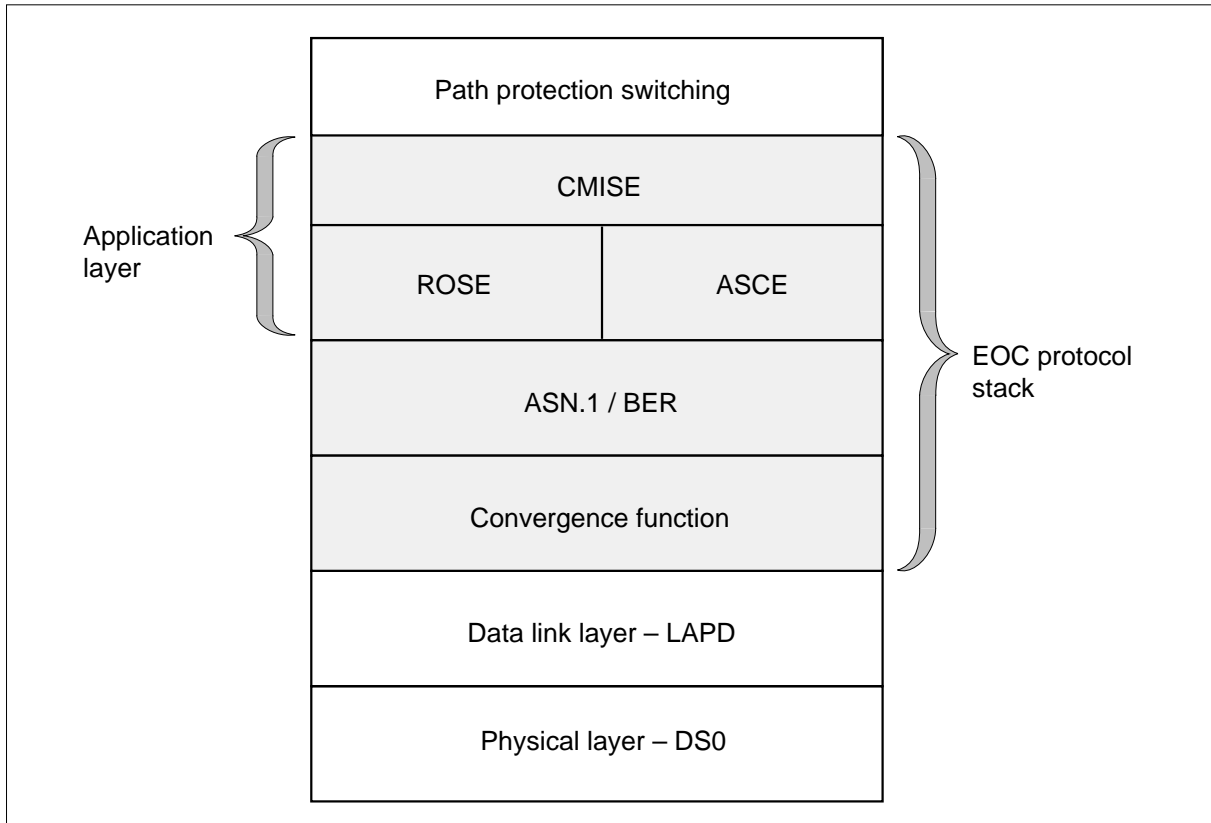
These elements appear in the following figure and a discussion appears in the text that follows.

Figure 3-17 OGW software functional elements

The EOC communication protocol contains the following functional areas:

- physical layer-which is the physical DS-0 channel on the first DS-1 link between the local digital switch (LDS) and the RDT
- data link layer-which uses LAPD protocol for processing between the LDS and the RDT
- EOC protocol stack-which is a 3-layer communications protocol stack that communicates OAM&P information between the IDT and the SMA2. A description of this stack appears later in this section.
- path protection switching-which handles redundant messaging paths and the mechanism of switching activity between the paths

These functional areas perform common management information service element (CMISE) message transfers between the LDS software and the RDT. The relationship of the EOC communication protocol functional areas appears in the following figure.

Figure 3-18 EOC communication protocol functional areas

The encoding and decoding of line test EOC messages occurs in the SMA2. Encoding and decoding in the SMA2 and not the computing module (CM) improves real time performance for line tests. Encoding and decoding of line test EOC messages occurs for the following:

- metallic test access unit
- test response circuit
- metallic test access path termination
- analog line termination

EOC protocol stack

The EOC protocol stack is a 3-layer communications protocol stack. Use of the stack occurs to communicate operations, administration, maintenance, and provisioning information. This communication occurs between the IDT and the SMA2 and the RDT over the EOC communications channel. The EOC protocol stack appears in the figure; EOC communication protocol functional areas. The EOC protocol stack contains the following layers:

- convergence function layer—performs the segmentation and re-assembly of application protocol data units (APDU). The convergence function

layer performs the mapping between the services of the application and data link layers.

- application layer—contains the following functionalities that allow communication between two application processes:
 - common management information services (CMISE) that exchanges information and commands to manage the SMA system
 - remote operations service element (ROSE) that supports communication between communicating application users
 - association control services element (ASCE) that controls application associations
- abstract syntax notation one (ASN.1) layer—uses basic encoding rules (BER). The ASN.1 parses and formats messages from functional subcomponents

Applications router

The application router provides the internal connection between the operations entities and the EOC protocol stack.

Operation entities

Operations entities are DMS SuperNode applications or external devices. Operation entities are the source or end point of operations messages between the SMA2 and the RDT. These entities use the EOC protocol stack to communicate over the EOC with the RDT.

The IDT software sends messages over the EOC to allow operations entities to perform OAM&P tasks. The following applications are external to IDT software and communicate with IDT software:

- line provisioning that controls the datafill of subscriber services
- line maintenance that allows controlling and monitoring subscriber line states from the MAP terminal, and permits diagnostic tests of the lines
- logs and alarms that allow the system to report alarms and events at the MAP terminal and external operating systems
- node maintenance that provides for the control of voice and data channels between the CM and the SMA2 and RDT.

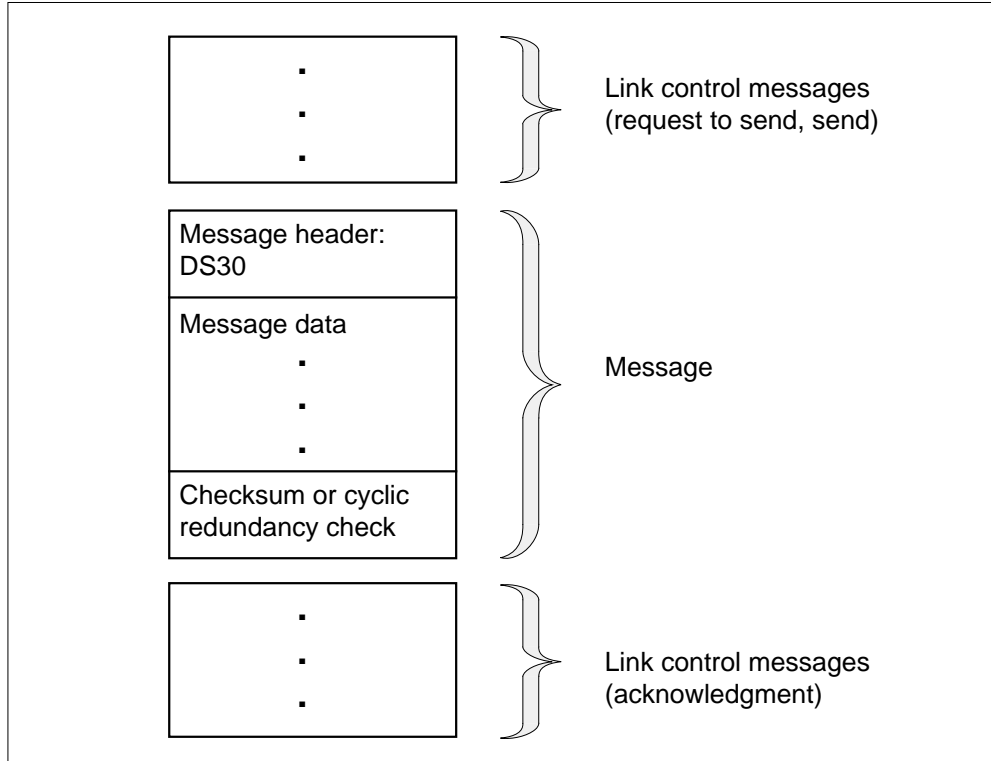
The IDT software communicates with an RDT over an LAPD channel.

DS30 protocol

The DS30 protocol is a half-duplex protocol used on DS30 or DS512 links. The DS30 protocol includes a message checksum for error detection.

The DS30 protocol is a handshaking protocol. Handshaking protocol is for message transfer between nodes. This message transfer allows the nodes to inform other nodes of the node condition for messaging. A general form of handshaking protocol appears in the following figure.

Figure 3-19 Handshaking protocol



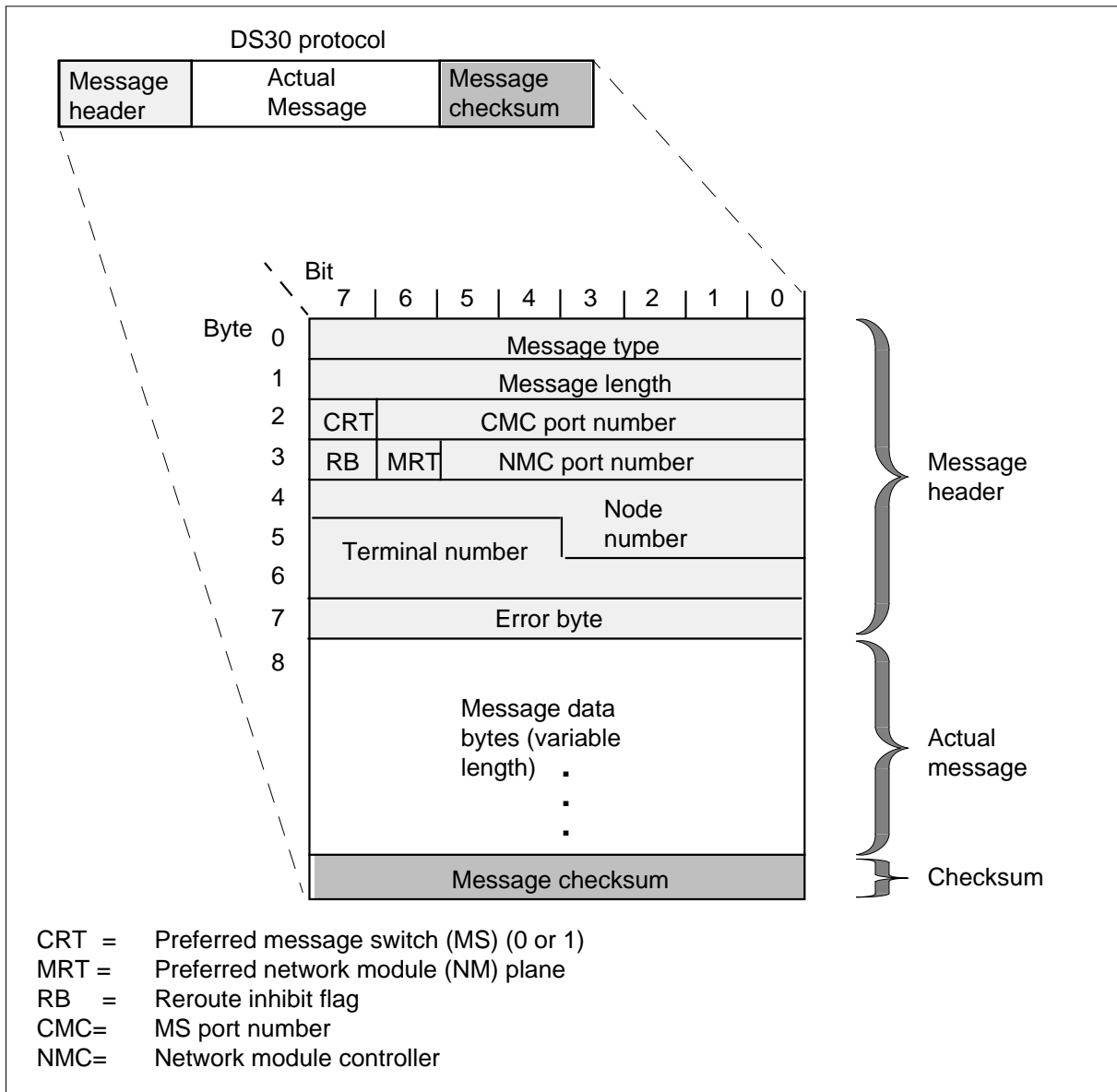
Message time-out and message checksum or CRC calculation performs message error detection. If protocol, checksum, or CRC failure on an outgoing message occurs, the sending node tries the send sequence again.

On an incoming message failure, the sending node reroutes the message over an alternate control side (C-side) link. Hardware redundancies provide a minimum of one other path to and from a node.

The DS30 message transmits over a link, with link control messages before and after the message. From a software aspect, messaging occurs between programs that execute in the SMA2 and programs that execute in the CM. Many software tasks or processes communicate with messages over the DS30 links.

The design of DS30 messages appears in the following figure.

Figure 3-20 DS30 message format



The DS30 message header is the first 8 bytes as follows:

- The first byte specifies the message type
 - control (1 byte)
 - start of message (SOM), for data
- The second byte specifies the total number of bytes in the message.

- The next 2 bytes specify the route, and contain the following fields:
 - CRT that specifies the preferred message switch (0 or 1)
 - MRT that specifies the preferred network planeThe CRT and MRT fields are for incoming messages and are set to zero for outgoing messages.
- The next 3 bytes contain the terminal identifier (TID), which identifies the destination node and terminal number for outgoing messages. The TID identifies the origination node and terminal number for incoming messages.
- The last byte is the message checksum byte field. This field contains a checksum over all bytes in the message. The last byte detects transmission errors.

The number of bytes in the message or data is variable.

ADSI protocol

Analog Display Services Interface (ADSI) allows application software to download softkey information to customer premise equipment (CPE). The ADSI provides bi-directional communication between the DMS SuperNode switch and a CPE. These abilities require the ADSI protocol for support. The ADSI protocol uses standard dual-tone multifrequency (DTMF) signaling and standard modem based technology, for transmission of caller_id information from a DMS SuperNode switch to a CPE.

The SMA2s acts as a message transfer agent between CM and the CMR circuit card in ADSI protocol. The SMA2 and CMR act as an interface between CM application software and an ADSI compatible CPE. Any message sent to the SMA2 to support ADSI forwards to the CMR. The CMR forwards the correct information to the CPE. The features that use the ADSI protocol are:

- Visual Screen List Editing (VSLE)
- Call Logging
- Deluxe Spontaneous Call Waiting Identification (DSCWID)

To support the ADSI, protocol, the DMS SuperNode switch supports the following interfaces:

- the off-hook interface and protocol that TR-NWT-000030 (TR-30) defines
- the ADSI interface and protocol that TR-NWT-001273 (TR-1273) defines

TR-1273 divides the ADSI protocol in three layers. The layers are the physical, data link, and message layers.

Physical layer

The physical layer transmits the bit streams between the DMS switch and the CPE. The DMS Supernode switch must be able to generate a voice band CPE alerting signal. The DMS Supernode must be able to receive standard DTMF signals from the ADSI CPE.

Data link layer

The data link layer provides data transmission between a DMS SuperNode switch and the CPE. This layer checks for error detection and correction.

Message layer

The message layer controls the character set and data codes when data appears on the CPE.

Call processing

The SMA system can perform call processing through Q.921, Q.931, and DS30 protocols and CSC message signaling or TR-303 hybrid signaling.

Call processing can originate from the RDT. Call processing can originate or from remote users that have calls that terminate on an RDT that subtends from the SMA2. For both conditions, the SMA2 provides the translation between the Q.931 generic-based messages of the RDT and the DS30 message format the host understands.

Call processing (RDT to IDT)

The following call processing description, traces the call from the RDT to the DMS SuperNode switch through the IDT. The description is for POTS/COIN calls. The ISDN calls can vary.

Time slot request

When the subscriber that originates a call goes off-hook, a loop closure occurs. Current flows in the loop, and exceeds a set threshold. The RDT line card detects this current. Coin calls made from coin first equipment have loop closure after a caller deposits a coin.

The RDT uses the TMC or CSC message channel to send a setup message to the IDT. The call state is call-initiated. This message contains the call reference and bearer capability associated with the subscriber line that goes off-hook.

After the RDT sends the setup message, the RDT sets a timer and waits for a setup acknowledge or a release-complete message. The IDT sends the setup acknowledge or release-complete message. If a response does not occur in the specified time lapse, the RDT transmits the setup message again. If a response does not occur, the RDT sets a delay timer. The RDT continues to transmit setups until the IDT responds or the subscriber goes on-hook.

Channel selection

The IDT reserves an available channel for the call and sends this information back to the RDT in the setup acknowledge message.

As the IDT sends the setup acknowledge message, the IDT connects the call to the allocated channel. When the RDT receives the setup acknowledge message, the system connects the allocated channel to the line termination of the originating call.

When the system makes the connection, the IDT sends dial tone over the connected channel. The call is in an overlap sending state.

If there are no available channels, the IDT sends a release complete message to the RDT. The cause information element specifies the reason. The IDT returns the call to a null state.

Sending addressing information

Digits collection occurs in one of two methods. If the subscriber loop uses dial pulse or dual-tone multifrequency dialing (DTMF) determines the method.

- If the RDT receives dial pulse input, the RDT sends an information message to the IDT with this address information. The RDT uses keypad facility information elements.
- If the RDT receives DTMF input, the RDT sends this information to the IDT in-band. The universal tone receiver decodes the information.

The addressing information forwards to the computing module (CM) in the DMS SuperNode switch.

Tone generation

The CM receives the addressing information and determines if the address is a valid number. The CM tries to set up a channel for the call through the network. When the CM sets up a channel through the network, the IDT sends a connect message to the RDT. The call is in an active state.

The CM can determine that the addressing information is from a toll or coin line. If this event occurs the IDT sends a notify message to the RDT. The notification indication information element is encoded as reverse battery to indicate toll diversion. When the RDT receives this message, the RDT sends reverse battery on the subscriber line.

If the CM determines the addressing information is invalid, or cannot establish a connection through the network, the channel remains open. The channel remains open to allow the DMS SuperNode switch to provide in-band call progress information, like reorder tone, to the subscriber.

The message and channel supervision messaging (CSM) card (NTMX76BA) in the SMA2 generates dial tone. The matrix card (NTMX75BA) switches the tone under directions from the NTAX74AA cellular access processor (CAP) card to the correct DS-1 channel. If the called line is busy, the NTMX76BA generates a busy tone. The system sends the tone to the originating party. Originating subscribers can receive other treatments, like reorder tone and announcements. Conditions present at the time of the placement of the call determines the treatment.

Call disconnection

The IDT and RDT continuously monitor the call for new messages. A system can have a disabled flash and either end can go off-hook without flash detection for 250 ms or more. If this event occurs the system sends a disconnect message to the far end. This message is a request to release the time slot and call reference. With flash enabled, the on-hook signaling bit pattern must persist for minimum 1200 ms. This event must occur for the IDT or RDT to send a disconnect message. At the same time, a timer is set at the disconnect-message end. If the IDT began call clearing, the call is in a disconnect indication state. If the clearing began at the RDT, the state is disconnect request.

In response to this message, the far end sends a release message that indicates the time slot and call reference are released. A timer is set at release-message end. When the release message is received, cancellation of the disconnect-message end timer occurs. The system sends a release complete message to the other end. This condition indicates both the time slot and the call reference are released for future use.

A release message is not always received before the disconnect-message end timer expires. If this event occurs the end that sent the disconnect message sends a release message and sets a timer. A release complete message is not always received before this new timer release-message end expires. If this event occurs the end sends a second release and the timer restarted. If there is no response to the second release, the system releases the call reference and time slot.

Flash detection

Flash can be enabled and an off-hook subscriber can go on-hook for less than 250 ms. If this event occurs the system treats the off-hook as a glitch and the call connection remains. The subscriber can go on-hook for 250 ms or 360 ms and can go off-hook before 1200 ms expires. If this event occurs the system treats the sequence as a flash. This action occurs 1200 ms from the time the subscriber goes on-hook.

Detection of a flash can occur on lines that use dial pulse and DTMF at the RDT. The detection is encoded in an information message with the keypad

facility information element. The system sends the information message to the IDT and is processed when the call remains in an active state.

If the caller subscribed to call transfer or to three-way calling, the RDT sends an information message. This message is the same message that occurs when the RTD detects a flash. The call enters in an overlap sending state to allow for additional digit collection. The message exchange for the set up of the second call is the same as another set up. This identical set up is the the set up of a simple end-to-end call. The message reaches the second party and the IDT receives a second flash information message. The call becomes bridged or transferd.

Detection of a call can occur in the overlap sending state when a subscriber activates features like call forward. These features do not require an established call.

Busy service of subscriber lines

The CM can direct the SMA2 to busy a subscriber line. This action prevents call processing on the subscriber line. Execution of this action normally occurs during maintenance. An example of this action occurs when the user enters a MAP command from the LTP level to test a line.

Call processing (IDT to RDT)

The following call processing description traces the call from the DMS SuperNode switch through the IDT to the RDT. The description is for POTS/COIN calls. ISDN calls may vary.

Time slot request

With the TMC or CSC message channel, the IDT sends a setup message to the RDT. The call is in a call present state. The setup message contains the call reference and bearer ability that associates with the subscriber line that originated the call. The message contains channel identification, and can contain the signal information element.

After the IDT sends the setup message, the IDT sets a timer. The IDT waits for a call proceeding, alerting, or releasing a complete message from the RDT. If a response does not occur in the specified time lapse, the IDT sends the setup message again. If a response does not occur, the IDT releases the call reference and channel. The IDT sends a release complete message to the RDT with the reason specified in the cause information element. The IDT returns the call to a null state.

Network busy call treatment

If the network is busy, the NTMX76BA message and CSM card in the SMA2 generates a reorder tone to the originating party.

Channel selection

In the setup message, the IDT indicates the channel for use with call connection with the channel identification information element. If the channel is not available, the RDT sends a release complete message back to the IDT.

If the channel is available, the RDT replies with an alert message or connect message that contains a channel indication information element. The channel indication information element confirms the channel the IDT reserved for the call.

If the called line is busy, the NTMX76BA message and CSM card in the SMA2 generates a busy tone. This tone goes to the originating party.

Alerting

The setup message received at the RDT can be sent with alert information encoded in the signal information element. When this condition occurs the RDT sends the alerting message back to the IDT. An alerting message indicates that the RTD alerted the called party. The call is in the call received state. When a called line rings, the originator receives a ringback tone.

The SMA2 supports the single-party alert cadence. Ringing abilities include single-party 20 Hz ringing and distinctive ringing for Meridian Digital Centrex (MDC).

The ringing cadences that SMA2 supports appear in the following table.

Table 3-6 SMA2-supported ringing cadences

Ring types	Ringing cadences (in seconds)					
	On	Off	On	Off	On	Off
single party	2	4				
distinctive 1	1.5	4.5				
distinctive 2	1.5	.5	1.5	1.5		
distinctive 3	1.5	.5	.5	3.5		
distinctive 4	1.5	.5	.5	.5	.5	2.5
distinctive 5	1.5	.5	.5	.5	1.0	2.0
distinctive 6	1.0	.5	1.0	3.5		
distinctive 7	.5	.5	.5	.5	1.0	3.0
distinctive 8	.5	.5	1.0	.5	.5	3.0

When the called subscriber goes off-hook, the RDT detects the change in the line current and sends a connect message to the IDT. This message trips the ringing. The call is in a call active state.

On-hook transmission

On-hook transmission allows the network to transmit information like calling number delivery (CND) to the called subscriber. Calling number delivery is an example of an on-hook transmission service that is coincident with a terminating call. Other on-hook transmission services, like message delivery, are not coincident with call terminations.

Custom local area signaling service (CLASS) calling number delivery (CND)

If the RDT receives a setup message, the RDT responds with an alerting message. The call is in the call received state. The system delivers the calling number during the first silent ring cycle.

When the called subscriber goes off-hook, the RDT detects the change in the line current and sends a connect message to the IDT. This message trips the ringing. The call is in a call active state.

Loss padding

Padding or attenuation of pulse code modulation (PCM) samples occur in the ring/pad card. The PCM samples compensate for expected signal loss through the network. The CM directs the SMA2 to apply padding to specified lines. The NTMX75BA matrix card in the SMA2 provides the padding and the enhanced time switch circuit card. The NTAX74AA Cellular Access Processor (CAP) circuit card directs this provision. The NTMX75BA matrix card introduces the padding to appropriate channels.

Call disconnection

The IDT and RDT continuously monitor the call for new messages. If flash is in the disabled state, one end can go on-hook for a minimum of 250 ms. If this condition occurs, the IDT or RDT sends a disconnect message to the far end. This message is a request to release the time slot and call reference.

With flash enabled, the on-hook signaling bit pattern must continue for minimum 1200 ms. This action must occur for the IDT or RDT to send a disconnect message. At the same time, the disconnect-message end sets a timer. If the IDT began call clearing, the call is in a disconnect indication state. If the clearing began at the RDT, the state is a disconnect request.

To respond to this message, the far end sends a release message. This message indicates the release of the time slot and call reference. The release-message end sets a timer. When the release-message end receives the release message cancellation of the disconnect-message end timer occurs. The system sends a

release complete message to the other end. This message indicates the release of the time slot and the call reference for future use.

The release-message end does not always receive the release message, before the disconnect-message end timer expires. If this event occurs the end that sends the disconnect message sends a release message and sets a timer. A release complete message is not always received before this timer release-message end expires. If this event occurs the end that sends the disconnect message sends a second release and sets the timer again. If there is no response to the second release, release of the call reference and time slot occurs.

Flash detection

Flash can be enabled and an off-hook subscriber can go on-hook for less than 250 ms. If this event occurs the system treats the condition as a glitch, and the call connection remains. The subscriber can go on-hook for 360 ms or more and can go off-hook before 1200 ms expire.

A flash is detected on lines that use dial pulse and DTMF and processed by the IDT while the call remains in an active state.

If the caller subscribed to call transfer or to three-way calling, the system places the call in an overlap sending state. This action allows for additional digit collection. The message exchange to setup the second call is the same as the exchange for a simple end-to-end call. After the message reaches the second party, and the IDT receives a second flash, the call transfers or becomes bridged.

Busy service of subscriber lines

The CM can direct the SMA2 to have an RDT busy a subscriber line. This action prevents call processing on the subscriber line. This action normally occurs during maintenance. An example of this action occurs operating company personnel enter a MAP command from the LTP level to test a line.

Call processing coin operation

Coin commands

Call processing coin operation uses the following commands:

- coin collect
- coin return
- coin presence
- coin partial presence (for local coin overtime)

Coin collect

This command directs a coin first (CCF) or coin dial tone first (CDF) telephone to collect coins deposited for a call. When the caller first deposits coins, the coins go to the hopper. The hopper is a temporary holding location that stores coins before coin collect or coin return. When the system receives the coin collect command, the coins drop from the hopper to the coin vault.

On coin telephones that require a flat rate, collection of the coins occurs when the call completes. Some coin telephones connect to a switching system that supports local coin overtime (LCO). On these telephones, collection of the coins occurs after a specified number of minutes.

Coin return

After the caller deposits coins, a coin return command directs the coin telephone to return the deposited coins. This action occurs when the calling party on a coin telephone disconnects before the terminating party answers.

When channel reassignment occurs and the system cannot reassign the call, the system drops the call for a higher priority call. Or, if the system cannot connect a call because all channels are busy, the system sends a coin return message.

Coin presence

This command directs CDF telephones to check for a first deposit or stuck coins. This command checks for stuck coins for CCF telephones.

An operator processes long distance calls on CCF and CDF telephone. The operator monitors tones the telephone station generates. The coins deposited determine the tones.

Coin partial presence

Use of this command occurs on CCF and CDF telephones when the telephones support LCO. The coin partial presence test checks for coins deposited after the initial deposit.

Battery commands

In addition to the coin commands, the CM can send or instruct the RDT to send reverse battery and normal battery.

Reverse battery

All types of coin telephones use this command. This command prevents communication between the calling and called parties. This command:

- resets the telephone totalizer, an electromechanical device that totals initial rate deposits
- prepares a telephone station for calling
- signals coin types to the operator

Normal battery

This command allows the talking state. This command resets the totalizer on some CDF and CCF telephones.

Subscriber line signaling

The in-band tone multifrequency analog signaling can operate on subscriber lines that subtend the RDT. When this condition occurs the SMA2 transparently transports these coin commands.

Changes to the electrical condition on the loop (metallic signaling) can make the signaling on the subscriber lines that subtend the RDT. When this condition occurs, the IDT must translate the coin commands to notify messages. These messages must contain the notification indicator information element.

When the RDT receives the notify messages from the IDT, the RDT applies voltages or opens to the tip and ring of the line. These electrical signals applied to the tips and rings of coin telephone lines cause the coin station to initiate actions. Examples of these actions are the return of a deposit to a station user, or the collection of a deposit.

Coin operation limits and interactions

The following limits apply to coin functions. Initiation of coin telephone calls, like all calls, cannot occur during a warm switch of activity (SWACT) or call processing (CP) switchover. This condition occurs because of inhibited messaging between the SMA2 and RDT.

Note 1: If a DS-1 link fails, the system causes channel reassignment. If a coin line call occupies a channel on the failed link and system cannot reassign the call. The SMA2 sends a coin return message to the RDT. The telephone returns the coins the station user deposited.

Note 2: When a warm SWACT occurs, calls that just entered the talking state are not added to the records of the current active unit. The system drops the call, and coins deposited return to the telephone station user after the user originates again and disconnects.

SMA2 service capabilities

This section describes the services the SMA2 supports. Only switched services terminate on the SMA2. Tandem DS-1 links at the RDT direct nonswitched and nonlocally switched services.

Plain ordinary telephone service (POTS)

The SMA2 supports plain ordinary telephone service (POTS) single-party flat rate and single party multi-rate.

Coin operation service

The SMA2 supports the following three types of coin calls:

- coin first (CCF)
- coin dial-tone first (CDF)
- coin semi-post pay (CSP) (for S/DMS AccessNode)

Coin first

Coin first (CCF) service requires the pay station telephone to be off-hook. The CCF requires that the caller deposit coins before the DMS SuperNode switch supplies the station dial tone.

For CCF telephones, the caller must deposit the correct number of coins before the detection of the off-hook occurs at the RDT.

The IDT sends a notify message with timed positive coin check information encoded in the notification indicator information element. When the RDT receives this message, the RDT signals the coin station to check for the first coin deposit.

The IDT sends a notify message with ground start mode information encoded in the notification indicator information element to the RDT. When the RDT receives this message, the RDT sends reverse battery on the line. This action causes the coin station to home the coin station totalizer. The coin station reports on the coins the coin station collected.

If the caller deposits the correct coins, the RDT sends the IDT a notify message. This message contains coin ground information in the notification indicator information element. This information informs the CM when the caller deposits a coin.

The IDT sends an information message with negative ring information encoded in the signal information element to the RDT. This message allows the calling party in the coin station to receive ring-back. If the called party is on the telephone, the IDT sends a disconnect message. An information message to allow ring-back follows the disconnect message.

If the call is a number for where there is no applied tone, the IDT sends a notify message. This message has the timed negative coin control information encoded in the notification indicator information element. When the RDT receives this message, the RDT signals the coin station to return the coins the caller deposited.

For toll calls, coin functions can occur when the CCF line goes on-hook. When the call completes, the IDT sends a notify message. This message has the timed positive coin control information encoded in the notification indicator

information element. When the RDT receives this message, the RDT signals the coin station to collect coins.

Coin dial-tone first

For coin dial-tone first (CDF) service, the DMS SuperNode switch supplies dial tone when an off-hook condition occurs at the station. The call fails to go through unless the calling party deposits the correct number of coins before the end of dialing.

When a caller makes a call from a CDF telephone, the CM requests information on a coin deposit. The IDT sends a notify message that contains a coin presence request in the notification indicator information element. When the caller deposits a coin, the RDT sends the IDT a notify message to respond to the request. This message contains coin ground information in the notification indicator information element. This information informs the CM when a caller deposits a coin.

If the call is to a number with no applied toll, the IDT sends a notify message. This message has the timed negative coin control information encoded in the notification indicator information element. When the RDT receives this message, the RDT signals the coin station to return the coins the caller deposited.

When the call is complete, the IDT sends a notify message. This message has the timed positive coin control information encoded in the notification indicator information element. When the RDT receives this message, the RDT signals the coin station to collect coins.

Coin semi-postpay

For coin semi-postpay (CSP) service, the DMS SuperNode switch provides dial tone, allows dialing, and connects the station caller with the called party. The DMS SuperNode switch allows talking when the caller deposits coins.

The IDT sends a notify message with positive loop mode information encoded in the notification indicator information element to the RDT. When the RDT receives this message, the RDT sends reverse battery on the line. This action causes the coin station to home the coin station totalizer. The coin station reports on the coins the coin station collected.

Use of coin collect, coin return, or coin presence tests cannot occur for CSP lines. Only use of reverse battery can occur for CSP lines. Reverse battery allows an originator to hear the terminating party, and the terminating party cannot hear the originator.

If the caller deposits the correct coins, the system applies normal battery to allow the calling party to hear the called party.

When a channel is established, the system sends dial tone and collects digits. When this condition occurs the CM of the DMS SuperNode switch sends commands to the RDT. This command regulates and monitor the collection of coins.

Coin call functionality

Use of many coin call messages occurs when the system processes coin calls from CCF, CDF, and CSP telephones. The CCF telephones use ground start and CDF and CSP, which applies to S/DMS AccessNode only, use loop start. Ground start and loop start messages are as follows:

- Ground start telephones require an initial deposit before provision of dial tone occurs.
- Loop start telephones allow the caller to receive dial tone without a deposit. Loop start telephones allow the caller to dial the following calls without charge:
 - special assistance calls (n11 calls, like 911 and 411)
 - inward wide area telephone service (INWATS)
 - operator assistance calls

The caller must first deposit a coin. When the CCF makes the call, the system returns the coin.

Message waiting indicator

The message waiting indicator allows subscribers to have several messages stored against a station in the DMS SuperNode switch or at a message center. When the system queues a message against the station of the subscriber, the system activates the message waiting indicator.

Message waiting lamp

The message waiting lamp feature is available on S/DMS AccessNode. This feature indicates that a response to a request by another station requires action. The request can be of the types message waiting or call request. To activate the message waiting lamp, the IDT delivers a notify message. The message has the notification indicator element encoded to Turn On Lamp to the RDT. To deactivate the message waiting lamp, the IDT delivers a notify message. This message has the notification indicator element encoded to Turn Off Lamp to the RDT.

Meridian business set messaging

Meridian business set (MBS) is a generic term that describes many Nortel-proprietary customer premises equipment models. These models support features like hands-free communication, volume control, and key-driven feature activation. The MBS is an electronic business set (EBS).

DMS-100 Business Set Feature Description and Operation describes the MBS services.

MBS on AccessNode

The MBS is a Nortel product that normally connects to a line concentrating module (LCM). The DMS SuperNode switch and MBS communicate with a proprietary protocol when MBS sets connect to an AccessNode.

The CSC uses the protocol in which a protocol discriminator #4F (hex) and then a variety of message types denote nonproprietary messages. To allow proprietary communication over the CSC for an MBS, the CSC uses a different protocol discriminator, #FA. When a message is proprietary, the message type indicates the type of service offered. The message type for an MBS is #7F.

The proprietary protocol discriminator and message type expands the ability of the SMA2 to support MBS communication. This feature allows the SMA2 to support the same MBS communication as when the MBS configuration is off an LCM. The MBS supports the same feature set.

MBS on MVI RDT

The MBS on MVI RDT supports the same Q.931 messages as the AccessNode. The EBS messages use the #4F (hex) message to differentiate EBS messages from standard TR-303 messages. Processing starts for the proprietary MBS protocol.

The normal provision of MBS lines are on a TR-303 RDT. This condition occurs because default values for TMC LAPD parameters are large enough to support a proprietary EBS INFORMATION information message. The system sends this message over the TMC for MBS. The electronic business set (EBS) message allows the RDT to pass signaling and feature-related information between the DMS and MBS.

The TMC signaling handles proprietary MBS call-related messaging. All ABCD bit inband signaling for MBS channels is disabled because MBS sets require a clear channel.

Universal tone receiver services

A universal tone receiver (UTR) circuit pack (NT6X92BB) must be in slots 6 and 22 in the SMA2. Additional UTRs can be in in slots 7 and 21. The UTR card provides a dedicated channel for digit collection during call setup. This condition unloads the network for a part of call setup responsibility. The UTR card data must be entered in table LTCINV to activate the UTR feature on the SMA2. Refer to the *Translations Reference Manual* for more information.

Direct Outward Dial (DOD)

This feature allows the private branch exchange (PBX) or Centrex station user to access the exchange network without attendant help.

Custom local area signaling service

The SMA2 subsystem supports CLASS features when the optional CMR card is present. Calling number delivery (CND) is a CLASS feature. This CLASS feature allows single-party subscribers and Meridian Digital Centrex (MDC) customers to receive:

- the number of the incoming calling party
- time of call on the customer premises equipment (CPE)
- date of call on the CPE

If the operating company requires that lines off the RDT have CND, the following requirements apply:

- A CMR card (NT6X78AB) must be present in the SMA2. This card transmits the CND data.
- You must enter the CMR card data in table LTCINV. Refer to the *Translations Reference Manual* for more information.

Meridian Digital Centrex (MDC) features on 500/2500 sets and attendant consoles

The SMA2 configuration supports all current MDC features. The SMA2 does not support trunks. The MDC features that require trunks cannot terminate on the SMA2.

Multiple appearance directory number (MADN) feature

The SMA2 supports the multiple appearance directory number (MADN) feature. The MADN feature associates a single directory number to a group of line appearances in a customer group. The following are possible MADN arrangements:

- Multiple call arrangement (MCA) allows each group member to be active with different group members.
- Single call arrangement (SCA) allows one member in a group to be active at any time.
- Multi-bridged arrangement (MBA) allows only one call to be active in a group at any one time. The MBA allows other group members to bridge to the call.

- Single bridged arrangement (SBA) allows one call to be set up with an external party. The SBA allows one other member to bridge to the call.
- Extension bridging (EXB) allows one call to be set up with an external party. The EXB allows any other group member to bridge to the call for a three-way conference call.

MADN members provisioning The following table provides the MADN members provisioning rules for the SMA2 with an S/DMS AccessNode or AccessNode Express.

Table 3-7 SMA2 to S/DMS AccessNode/AccessNode Express MADN members provisioning rules

Parameter	Value	Meaning
Switch average members for each MADN group	4	The engineering guideline for the total number of MADN members or total number of MADN groups on a DMS SuperNode switch.
Maximum number MADN members/group assigned for each S/DMS AccessNode/AccessNode Express	16	The engineering limit for the maximum number of MADN members in a single MADN group on an AccessNode/AccessNode Express shelf
Maximum number MADN members/group assigned for each S/DMS AccessNode/AccessNode Express	16	The limit for how many MADN members in a single group that a group on an AccessNode/AccessNode Express can have assigned.
Maximum number MADN members/group assigned for each SMA2	16	This parameter is an engineering guideline. This guideline specifies the maximum number of members in a single MADN group that are lines off one or more AccessNode/AccessNode Express on the same SMA2.
Maximum number MADN members/group assigned for each group	32	This parameter is the member limit that any single MADN group can have assigned.
<p>Note 1: Enter the maximum number of MADN members assigned for each group in table OFCENG in field MAX_MADN_MEMBERS_PER_LSG.</p> <p>Note 2: For information about the traffic capacity of the AccessNode/AccessNode Express, please refer to <i>Traffic and Bandwidth Engineering Information</i>, 323-3001-152, chapter "Traffic engineering software tool."</p>		

Off-premise extension (bridged service)

The SMA2 configuration supports a connection between a remote extension station to a main station line that uses the MADN feature.

Private branch exchange (PBX) central office access

The SMA2 configuration supports connection of PBX to a central office that normally serves the PBX location. A station can receive calls through the attendant that directs the call to a station.

The station user can originate calls outside the PBX in two methods. The user can access the attendant that connects the station to an access line. The station user can bypass the attendant and dial an outside number directly with the direct outward dial (DOD) facility. This action requires that the station user first get permission.

Residential services

The SMA2 supports residential services that have features normally available with plain old telephone service (POTS). The SMA2 supports additional line features that were available only on MDC lines. The SMA2 includes essential line (ELN) services feature.

Secretarial line

The SMA2 supports secretarial lines. A secretarial line provides an answering service when the called party is not available to take calls. Called party lines are bridges to the secretarial line.

Teen service

The SMA2 supports teen service. Teen service provides multiple directory numbers for the same line. These numbers each have different ringing patterns.

Toll diversion

The SMA2 supports toll diversion. Toll diversion is a service that permits a PBX to block some station-to-station calls beyond a limited area.

Wide area telecommunications services

The SMA2 supports wide area telecommunications services (WATS). The SMA2 allows the charges from a measured number of toll calls in a specified geographical area to be available to a subscriber at a fixed monthly rate. The WATS lines can provide incoming service (INWATS), outgoing service (OUTWATS), or incoming and outgoing service (two-way WATS).

800 service

The SMA2 configuration supports 800 services. With 800 services, the called party subscribes to the service and pays for the toll calls made to a specified number. The system supports enhanced 800 service switching point (SSP) services in offices configured with SSP.

ISDN services

An ISDN provides voice and data services through one or more NTB02BA enhanced D-channel handler (EDCH) circuit cards and an NTB01AC enhanced ISDN signaling pre-processor (EISP) circuit card.

ISDN voice services provide the following:

- plain old telephone service (POTS)
- electronic key telephone service (EKTS)
- direct outward dial (DOD)
- network class of service
- call forwarding
- call pickup
- automatic callback (ring again)
- call hold and additional call offering (call waiting)
- flexible calling
- hunt groups
- calling-line id
- busy override
- authorization codes

The ISDN data services provide the following:

- circuit-switched data
- packet-switched data

Note: The SMA2 does not support digital trunking or primary rate access (PRA).

Ringling

The SMA2 supports the following ringling:

- single party (DMS Ring Code 0; TR-303 Code 40)
- distinctive, for MDC (DMS Ring Codes 1-8; TR-303 Code 42, 44, and 71-76)
- multiparty fully selective
- coded
- superimposed
- teen

- revertive
- immediate

Dialing

The system understands the following dialing codes:

- dial pulse
- dual-tone multifrequency dialing (DTMF)

Tones

The following tones are available:

- dial tone
- receiver off-hook
- audible ringback
- reorder
- busy

Deluxe Spontaneous Call Waiting Identification

Deluxe Spontaneous Call Waiting Identification (DSCWID) provides an interface to CPEs that comply with Bellcore specification TR-416. The DSCWID is a CLASS feature that allows a subscriber to:

- receive caller identification (CID) information from a call that waits to connect when the subscriber is off-hook
- control the disposition of incoming calls when an off-hook stable call is present

Bellcore TR-416 describes the requirements for DSCWID and specifies how this feature interfaces with:

- an ADSI set—a screen based ADSI CPE that can display options
- an SCWID set—a non-ADSI CPE that can deliver CID data
- a 2500 set—a non-ADSI CPE that can signal DTMF but cannot perform off-hook delivery of CID data

The NT6X78AB, NTMX76CA, and NT6X92BB or EA cards are required in the SMA2 to comply with ADSI protocol. Compliance with the ADSI protocol supports the SCWID/DSCWID feature. The ADSI protocol supports CLASS features that provide display-based information like DSCWID. These

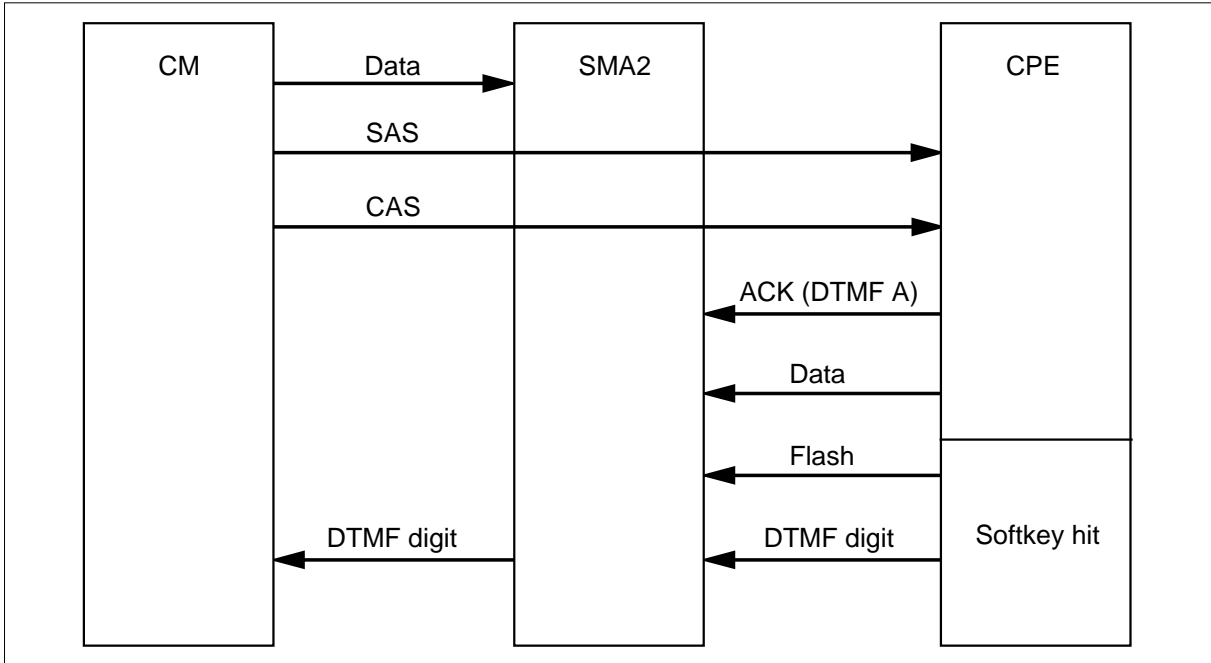
features are available to subscribers with CPEs that are compatible with ADSI. The cards function as follows:

- The NT6X92 UTR card identifies and processes tones for channels on the parallel speech bus.
- The NT6X78 CLASS modem resource (CMR) card supports calling number delivery (CND) and other CLASS services. The CMR card provides the ADSI protocol to transmit CLASS data between the CC and CPE that complies with ADSI.
- The NTMX76CA message and CSM card contains upgraded firmware required to support ADSI and SCWID/DSCWID.

Tones that the CM sends alert the SCWID/DSCWID subscriber of a pending call. These tones also alert the CPE of incoming caller data. A line with the SCWID/DSCWID option can have a call established and a second call can attempt to terminate to that line. When this condition occurs, the CM provides one of two types of alerting signals or tones. The two types of signals are a subscriber alerting signal (SAS) or a SAS followed by a CPE alerting signal (CAS). The SAS is the tone the subscriber recognizes as the call waiting tone (CWT). The CAS alerts the CPE of incoming data if the subscriber line also has the CID feature.

The SCWID/DSCWID CPE responds to the tones and generates an acknowledgement (ACK) tone in response to alerting tones. This tone indicates the CPE can receive SCWID data. The UTR circuit card in the SMA2 collects the ACK tone. If the CPE is compatible with ADSI, the CPE sends a DTMF A ACK signal in response to the CAS. The following figure describes examples of responses from a set that is compatible with ADSI.

Figure 3-21 Example of a DSCWID call on an ADSI set



If the CPE is a SCWID/DSCWID CPE, the CPE sends a DTMF D ACK signal in response to the CAS. When the CPE sends alerting tones, the subscriber can control the incoming call. The subscriber uses the CPE softkeys if the CPE is ADSI compatible. The subscriber uses hard-coded keys if the CPE is a SCWID or 2500 set. If the CPE does not respond with an acknowledgment tone, the CPE is treated as a 2500 set. The following figures describe examples of responses from a SCWID set and a 2500 set.

Figure 3-22 Example of a DSCWID call on a SCWID set

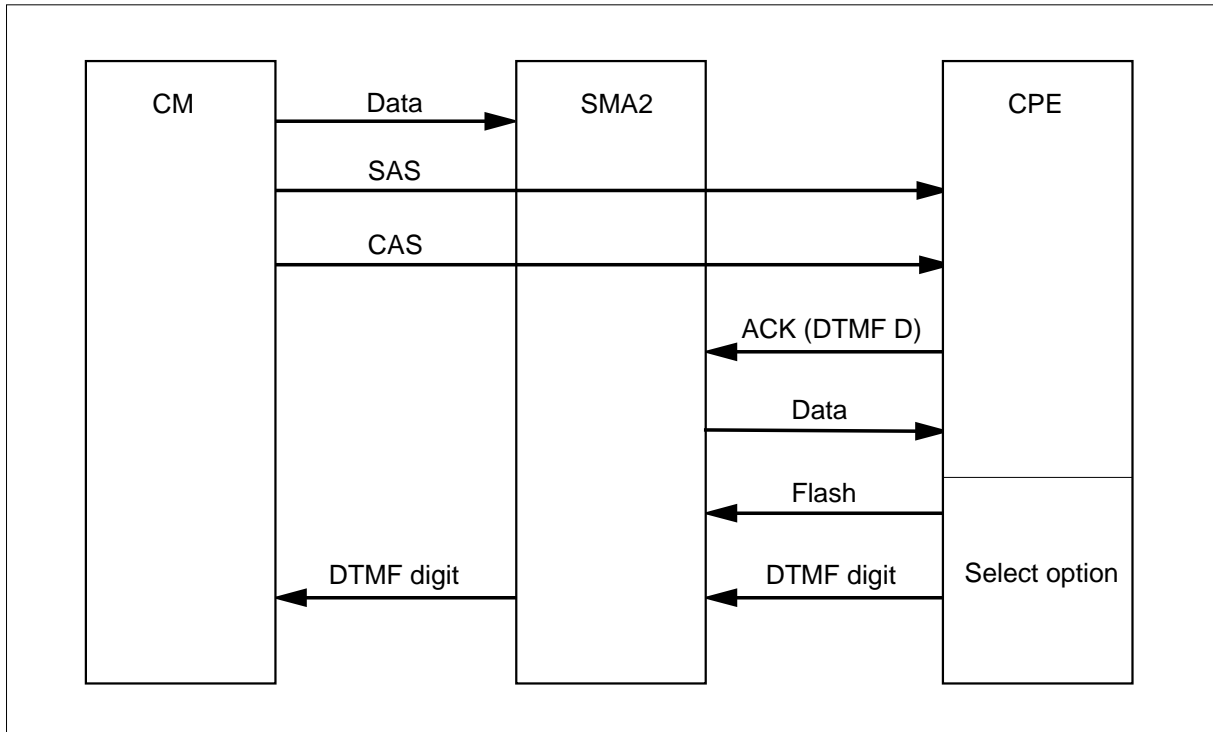
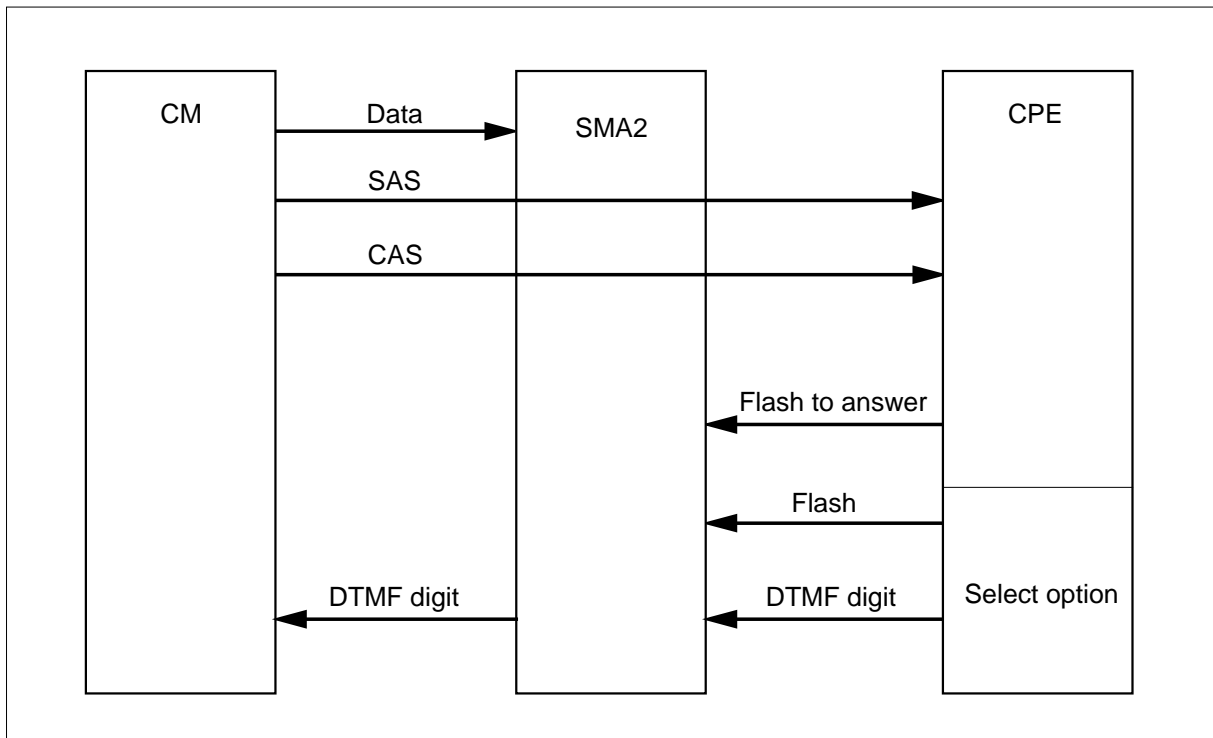


Figure 3-23 Example of a DSCWID call on a 2500 set



Alerting signals are sent to the CPE when a UTR channel is not available. If UTR channels are not available, data is not sent to the CPE. For Bellcore compliancy, the DMS SuperNode switch must provide options if the system detects a flash and cannot attach a UTR. The SMA2 complies with this requirement. The SMA2 sends a flash to the CM if the SMA2 cannot attach a UTR in 400 ms to comply with this requirement. If the CM does not receive the first notification of a pending call in 10 s, the SMA2 sends a second alerting signal. If display data was not sent to the CPE because UTR channels were not available, the SMA2 holds data. The SMA2 sends the data if re-alerting occurs.

After the SMA2 receives a flash signal from the customer CPE that is compatible with the ADSI, the SMA2 starts a T-tone timer. The T-tone timer times for the maximum amount of time allowed between a flash and the DTMF digit on an ADSI set. The timeout is 600 ms. The speech path is muted during this time. The T-tone timer is started for the initial option selection during a DSCWID call. The CPE type does not affect this condition. Following ADSI DSCWID option selections also start the T-tone timer.

DSCWID option selections which follow on a SCWID or 2500 set use a T-flash timer. The T-flash timer is used after a call is answered with SCWID and 2500 sets. This event provides the customer with enough time to select an option after a flash. The T-flash timer is used on these sets because a subscriber does not have enough time to flash and dial a DTMF digit in 600 ms.

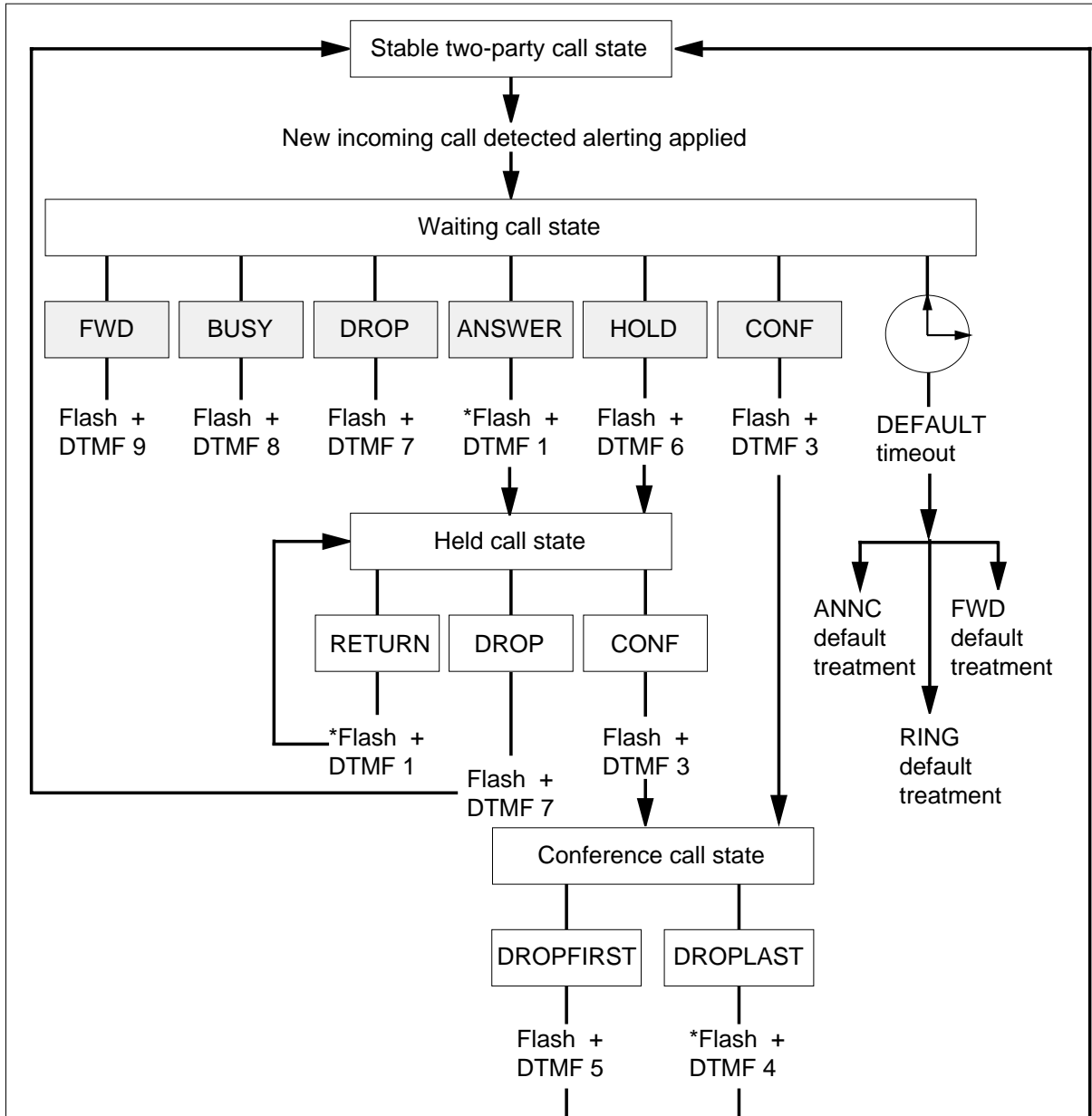
The operating company can set the T-flash timer from 1 to 8 s. The default is 1.5 s. The SMA2 starts the T-flash timer if the NONADSI field in table DSCWDTYP is set to Y. The SMA2 must also receive a flash signal from a customer's SCWID or 2500 set during the held or conference call state. The SMA2 must keep track of the DSCWID call state and the type of CPE. The timer used depends on this information. If the SMA2 cannot attach a UTR before 400 ms, the RETURN option is applied.

The CM attempts to remain synchronized with the CPE at all times. This close supervision prevents possible conditions where the DMS SuperNode switch does not process the option as expected, based on the call state. Call waiting dispositions options for the DSCWID are as follows:

- answer the new call and put the current call on hold
- disconnect the current call and answer the new call
- forward the new call
- connect the new call to a busy announcement
- put the new call on hold after connection to a hold announcement occurs
- conference the new call with the current call

The interaction between the ADSI set conditions appears in the following figure.

Figure 3-24 DSCWID with ADSI set conditions



Note 1: An * indicates a flash can be performed to accomplish the same function as ending the DTMF code for that digit

Note 2: The configuration of a non-ADSI set can be for hard-coded keys to perform DSCWID. The subscriber provides a DTMF-digit within 600 ms. If one of these events occur conditions can be available if NONADSI = Y in table DSCWDTYP for the given DSCWID type.

Preparing to datafill SMA2

PCL—New software delivery vehicle

After BCS36, Northern Telecom begins the delivery of Product Computing-Module Loads (PCLs) instead of BCS releases or Universal Software Loads (USLs).

A PCL contains features selected from the development stream software product. This product is for an specified application in a specified market. The PCL contains abilities divided between many related NTX packages before. An eight-digit ordering code replaces the NTX package codes.

The ordering code and functional group name required for the SMA2 appears in the following table. The table lists the earlier NTX package that is in the functional group. This capability associates with the SMA2.

Table 3-8 SMA2 ordering code

Ordering code	Functional group name	Former NTX package codes
BAS00003	SCM-100 Software for AccessNode	NTXF46AA—SCM Base
SMA00001	TR-303 Generic Interface	NTXT23AA—SMA TR-303 MVI-20
SMA00012	SMA ICB Links	NA

Tasks associated with datafilling SMA2

This section describes the tasks associated with the entry of data in the SMA2 with the DMS switch table editor. The SMA2 tables have several categories. These categories appear in the following datafill summary:

- test trunks, test lines, and service circuits in table CLLI
- the SMA2 and IDT datafill in tables SITE, LTCINV, LTCPSINV, RDTINV, and LNINV
- call processing translations in the trunks, lines, screening, and routing tables TRKGRP, TRKSGRP, TRKMEM, LINEATTR, LENLINES, and LENFEAT
- scan and signal distribution points in tables SCGRP and SDGRP
- metallic test access assignments in tables MTAMDRVE, MTAVERT, and MTAHORIZ

With the following translations sections, enter the TR-303 interface to the DMS SuperNode switch based on one of the following interface types:

- TR-303 interface for MVI RDT
- TR-303 interface for S/DMS AccessNode

Use the section that applies to the type of access vehicle that connects to the SMA2.

Static datalog tracking

Logs track changes to tables RDTINV, LTCINV, and LTCPSINV. These logs are TUPC100, TUPC101, TUPC102, and TUPC103. These logs indicate datafill changes. The logs provide a start point to recreate, debug, and solve field problems.

Indications available at the time of service degradation are not always enough to diagnose the problem that occurs in the field. This feature helps to correct this problem. For more information on TUPC logs, see the *XPM Log Reports Reference Manual*.

When to update static data

For the SMA2 to execute call processing, the SMA2 must know how the SMA2 links and lines are configured. The SMA2 must know which cards, ports, execs, and integrated digital terminals (IDT) are present. This information is static data because the information does not change as calls are processing. External and internal tables contain this information. An example of nonstatic data call processing connections established during call setup, and torn down when a call completes.

Static data downloads to the SMA if the following conditions occur:

- static data changed since the last time the data downloaded
- the SMA is made busy and returned to service.

A static data update does not occur under the following conditions:

- The static data checksum is successful. The static data checksum is calculated again when an RTS is performed and sent to the computing module. This condition occurs after a SMA2 dynamic static data update. This condition allows SMA2 units to return to service in less time.
- The data integrity audit of SMA2 static data verifies the integrity of the SMAs static data. This audit occurs for each IDT.

Note 1: When the static data in the DMS SuperNode host and the SMA2 do not match, data corruption can result. This condition can result in a mismatch between the DMS host and the SMA2 and the associated IDT. The DMS host determines a line is present, and the

SMA2 and the associated IDT determines the line is not present. This condition results in a lost call.

Note 2: The SMA2 SWACT can be initiated if the system detects static data damage in the active SMA2 unit. This condition prevents degraded performance because of static data damage.

Dynamic static data update

A dynamic static data update allows in-service SMAs to reconfigure the SMA2 and the SMA2 (P-side), and C-side links. The SMAs can preform this action without having to update the static data of the affected in-service IDT through an RTS. Changes to an IDT and modifications to SMA2 P-side links, and C-side speech links can occur with the SMA2 in-service. Changes to SMA2 message links require the SMA2 to be manually busy.

Dynamic static data updates do not eliminate all static data mismatch ISTb conditions. There are table control changes that affect static data in not supported data fields. These changes can cause the SMA2 to go ISTb.

DMS recognition of the switching unit and all remote locations

Table SITE contains data that allows the DMS SuperNode system to recognize the switching unit equipment. This data allows the DMS to recognize equipment for remote locations that home on to it. This table defines the site names for the remote location. Table SITE uses codes entered in table CLLI for switching unit trunk groups and the remote location. Table CLLI identifies the far end of each announcement, tone, trunk group, test trunk, national milliwatt test lines, and service circuit.

Feature AF5678, XPM Node Table Sync Redesign, consolidates critical XPM node information in one table, PMNODES. To make sure XPM units maintain synchronization of internal node and port tables, the CM maintains a copy for each XPM unit. The XPM units do not have to derive any data for the internal node or port tables. The active XPM unit no longer updates the inactive unit

tables that caused possible differences in the datafill of the tables. The CM downloads the same information to both XPM units during updates.

**DANGER**

The system can reject an attempt to add or change tuples in any inventory table. The system can reject the attempt if table space or node resources are not available.

The system can reject attempted changes to the inventory tables with Table Editor. The system displays an explanation and possible correcting actions. Busy and return to service an XPM. This action normally defragments the node tables. This action frees the required space. If XPM resources are not available, the following message appears::

The new node cannot be supported on SMA2 ACTION:
None, resources have been exceeded on this XPM.

Note: Table PMNODES must appear as entered before inventory tables in the entry sequence list.

SCM-100 Software for AccessNode

Functional group

Functional group: BAS00003

Feature package

Feature package: NTXF46AA SCM Base

Release applicability

The XPM10 and later versions

Requirements

To operate, SCM-100 Software for AccessNode contains the following requirements:

- Bilge, NTX000AA
- Common Basic, NTX001AA
- New Peripheral Maintenance, NTX270AA
- Local Features I, NTX901AA
- XPM PLUS, NTXR34AA

Description

The Expanded Subscriber Carrier Module-100 Access (ESMA) provides a connection between the Digital Multiplex System-100 (DMS-100) and Bellcore GR-303 compliant access vehicles. The S/DMS AccessNode is a Bellcore GR-303 compliant access vehicle. The Northern Telecom (Nortel) Interface Specification (NIS A217-2) modifies the S/DMS.

The DMS-100 supports the Bellcore standard GR-303 for the IDLC systems access vehicle called a remote digital terminal (RDT). An IDLC system contains a digital loop carrier (DLC), an RDT, and a local digital switch (LDS).

Note: In this section, RDT references apply to access remotes and the S/DMS AccessNode, called remote fiber terminals (RFT). Where the system requires references to the remote access vehicle, the term S/DMS AccessNode or RFT refers to the S/DMS AccessNode. The S/DMS AccessNode is the next generation digital loop carriers (NGDLC) from Northern Telecom.

The switch resources that serve an RDT are called integrated digital terminals (IDT). The SMA2 implements the IDT end of the standard IDLC GR-303 interface for Feature Set A (T1 interface). The SMA2 uses the time-slot management channel (TMC) signaling method for generic RDTs. The SMA2

SCM-100 Software for AccessNode (continued)

uses the common signaling channel (CSC) method for the S/DMS AccessNode.

The SMA2 operates in a DMS-100 SuperNode environment. The MVI supports the Enhanced Network (ENET) and Junctored Network (JNET). The MVI does not support the NT40 system.

Operation

The SMA2 is based on the current Subscriber Carrier Module (SCM) family. The SMA2 provides the normal advantages of integrating digital loop carriers. The SMA2 supports a new range of advantages with the use of GR-303 and SONET (Synchronous Optical Network) standards.

The SMA2 shares hardware technology with the current equipment from the SCM-100 Family. The SMA2 is a common peripheral module (CPM) based host peripheral module. The SMA2 contains a main shelf and one-half of one extension shelf. The extension shelf half has duplicated power and control to make sure reliability. The SMA2 has one active unit and one standby unit. If the active unit fails, the standby unit automatically takes control of traffic.

The SMA2 in a C28 Model B cabinet or a standard DMS-100 single bay frame. The SMA2 shares common frame and shelf design with current SCM-100 Family products. Each frame can contain a maximum of two SMA2s.

Each SMA2 module can connect to the DMS SuperNode network on the central-side (C-side). Each SMA2 can connect to one DS512 fiber optic link in Enhanced Network (ENET) offices. The SMA2 module connects to the DMS SuperNode network on the C-side through 3-16 DS30 links.

The SMA2 supports a maximum of 28 DS-1 links on the peripheral-side (P-side). The SMA2 supports the DS-1 links to provide interface with the S/DMS AccessNode. A single SMA2 can support a maximum of eight remote access vehicles. The SMA2 can support a maximum of 1344 lines for each S/DMS AccessNode. An S/DMS AccessNode can be configured on SMA2s that connect RDTs of 1344 lines.

The DMS-100 switch requires software functions to support the S/DMS AccessNode. The software functions are in the following categories:

- Call processing (CP): This feature translates between the signaling protocol and the proprietary signaling protocol. The signaling protocol has a GR-303 base. The signaling protocol is on the P-side of the SMA2. The

SCM-100 Software for AccessNode (continued)

proprietary signaling protocol is internal and is on the DMS SuperNode switch.

- Local digital switch (LDS) control: This feature provides the table control and maintenance functions. These functions support the DMS SuperNode switch resources that associate with the S/DMS AccessNode.
- Operations gateway (OGW): This feature supplies the routing and communication services that connect the S/DMS AccessNode to different operational functions.
- Integrated digital terminal (IDT): This feature provides the software interface for the SMA2 to communicate with the AccessNode. The IDT is a logical entity of the SMA2. The IDT identifies the elements of the SMA2 that associate with the S/DMS AccessNode. The IDT provides the base for control of the RFT.

Translations table flow

The SCM-100 Software for AccessNode does not affect translations table flow.

Limits

The SCM-100 Software for AccessNode has the following limits:

- the SMA2 supports a maximum of 48 DS-1 connections and a maximum of 28 DS-1 connections for each AccessNode
- the SMA2 supports a single method of signaling for each RDT
- a single SMA2 supports a maximum of eight RDTs (five ISDN RDTs)

Note: An SMA2 supports a maximum of 756 ISDN lines

- the system cannot delete an IDT if there are lines attached to the IDT
- the maximum number of different groups of activated signal distribution (SD) points to indicate the RDT activating an alarm, is 255 groups
- the SMA2 supports a maximum of 28 P-side links from the S/DMS AccessNode
- the S/DMS AccessNode supports a maximum of 2048 lines. However, because of a hardware limitation the maximum is 1344 lines.
- the maximum number of terminals for each RDT, is 4095 terminals. The maximum number of terminals on the P-side node of an SMA2 cannot exceed 7055 terminals.
- you can restore the S/DMS AccessNode ISDN lines when the DMS SuperNode switch has an upgraded release of NA006 or later releases. To perform this action, copy the data in fields DS0PT and TIMESLOT from

SCM-100 Software for AccessNode (continued)

dump to the restore side. Fields DSOPT and TIMESLOT are in read-only table RDTLT.

Interactions

The SCM-100 Software for AccessNode does not have functionality interactions.

Activation/deactivation by the end user

The SCM-100 Software for AccessNode does not require activation or deactivation by the end user.

Billing

The SCM-100 Software for AccessNode does not affect billing.

Station Message Detail Recording

The SCM-100 Software for AccessNode does not affect Station Message Detail Recording.

SCM-100 Software for AccessNode (continued)

Datafilling office parameters

The office parameters for SCM-100 Software for AccessNode appears in the following table. For additional information about office parameters, refer to the *Office Parameters Reference Manual*.

Office parameters used by SCM-100 Software for AccessNode

Table name	Parameter name	Explanation and action
OFCVAR	TOLL_DIVERSION_SIGNAL	<p>The toll diversion (TDV) option for private branch exchange (PBX) lines occurs through this parameter. All toll call attempts from the PBX line, with the TDV option set, result in a toll diversion signal. The toll diversion signal is a reversal or a wink. The TDV sends the signal to the PBX.</p> <p>After the TDV sends the toll diversion signal, the DMS-100 must wait for a disconnect from the PBX. Operating company personnel define the wait period. The wait period can be 0 to 100 ms.</p> <p>If the DMS-100 does not receive the disconnect signal in the specified time period, the DMS-100 processes the call.</p>
OFCOPT	XPM_MATE_DIAGNOSTICS_AVAILABLE	<p>To activate the XMS-based peripheral module (XPM) mate diagnostics, set this parameter to Y. The diagnostics are now available to the resident switch.</p> <p>The XPM mate diagnostic feature allows central control (CC) to diagnose an XPM unit. The CC diagnoses the XPM unit through the mate XPM unit.</p>
	VSLE_PRESENT	<p>Visual screen list editing. When this parameter is N (no), assign the analog services display interface (ADSI) line option to the subscriber line. This assignment allows access to the visual screen list editing (VSLE) feature. When this parameter is Y, the system accesses VSLE without the assignment of ADSI to the line.</p>

Datafill sequence

For SCM-100 Software for AccessNode the datafill sequence does not change.

SCM-100 Software for AccessNode (continued)

The following table indicates the datafill requirements for SCM-100 Software for AccessNode. The fields that relate to SCM-100 Software for AccessNode appear in this table.

Datafill requirements for SCM-100 Software for AccessNode (Sheet 1 of 4)

Table	Purpose of table
CLLI	Common language location identifier. Identifies the maintenance and test trunks used in the SMA subsystem.
SITE	Site. Allows the DMS switch to recognize the remote equipment. The equipment ties to the host.
LTCINV	Line trunk controller inventory. Inventories different peripheral module (PM) types. The PM types include the SMA2. The PM types do not include P-side link assignments.
CARRMTC	Carrier maintenance control. Allows the DMS switch administration to enter maintenance control information in peripherals, out-of-service limits, alarms and system return-to-service occurrences.
PMLOADS	Peripheral module loads. Stores a load map between the load names and devices where the loads reside. Auto load can locate load files without the intervention from operating company personnel.
PMNODES	Peripheral module nodes. Contains all nodes resident in XPMs for a given site. The system automatically enters this table.
LTCPSINV	Line trunk controller P-side line inventory. Identifies the SMA2 module type, number, and port identification of the P-side links.
ALMSCGRP	Alarm scan group. Records the circuit equipment, location, and card type. Serves as a head table for the correct scan points.
ALMSDGRP	Alarm signal distributor group. Records the circuit equipment, location, and card type. Serves as a head table for the correct signal distributor points.
ALMSC	Alarm scan. Identifies the functions that each of the assigned scan points in the alarm scan groups perform.
ALMSD	Alarm signal distributor point. Identifies the function that each of the assigned signal distributor points in the alarm signal distributor groups perform.
DCHINV	The D-channel handler inventory. Identifies the physical, service and channel allocation characteristics of D-channel handler (DCH).
Note: Use SERVORD to enter data for this table. This document does not provide a procedure or example of how to enter this table through SERVORD. Refer to the SERVORD section for an example of how to use SERVORD to enter data for this table.	

SCM-100 Software for AccessNode (continued)

Datafill requirements for SCM-100 Software for AccessNode (Sheet 2 of 4)

Table	Purpose of table
ISGDEF	The ISDN service group definition. Identifies the ISDN service group (ISG) numbers, PM type, the services provided, and the allocation of services to channels.
LTGRP	Logical terminal group. This table can contain a maximum of 32 logical terminal group definitions.
LTDEF	Logical terminal definition. Defines logical terminals in group and access privileges.
LTMAP	Logical terminal map. Maps the ISDN logical terminals to a LEN or terminal identifier (TEI). (Refer to Note.)
SPECCONN	P-Side to P-Side special connection. Defines special permanent dedicated connections through the SMA2.
RDTINV	Remote digital terminal. Allows the DMS switch administration to enter RDTs and the corresponding IDTs. This table contains the C-side connectivity information and RDT configuration information.
TMINV	Trunk module inventory. Identifies the trunk modules (TM) that contain test circuits that terminate test pairs that connect to RDT lines.
TRKGRP	Trunk group. Identifies the test circuits that associate with the maintenance and test trunks.
TRKSGRP	Trunk subgroup. Lists the additional information for each subgroup. The system assigns a subgroup to a trunk groups from the list in table TRKGRP.
TRKMEM	Trunk member. Identifies the circuits that associate with the test equipment. This equipment tests lines and trunks.
LINEATTR	Line attribute. Assigns line attributes to normal lines in table LENLINES. Assigns line attributes to Meridian stations and attendant consoles in the MDC translations tables.
LNINV	Line circuit inventory. Retains an inventory of subscriber lines and associated line cards.
RDTLT	Remote digital terminal line termination. Indicates the next operation for line object provisioning.
<p>Note: Use SERVORD to enter data for this table. This document does not provide a procedure or example of how to enter this table through SERVORD. Refer to the SERVORD section for an example of how to use SERVORD to enter data for this table.</p>	

SCM-100 Software for AccessNode (continued)**Datafill requirements for SCM-100 Software for AccessNode (Sheet 3 of 4)**

Table	Purpose of table
IBNLINES	The IBN line assignment. Defines the line assignments for each MDC station number. Refer to Note.
IBNFEAT	The IBN line feature. Defines the line features the user assigns to the MDC lines from the list in table IBNLINES. Refer to Note.
CDCLENS	Customer data change line. Lists the line equipment numbers (LEN) assigned to a customer group.
KSETINV	Business set and data-unit inventory. Stores inventory data for each line card slot. The Meridian business sets and data units contain assigned card slots. Refer to Note.
KSETLINE	Business set and data-unit inventory line assignment. Defines the data for directory number appearances on Meridian business sets and data units. Refer to Note.
KSETFEAT	Business set and data-unit inventory line feature. Defines the line features assigned to business sets and data units from the list in table KSETLINE. Refer to Note.
LENLINES	Line assignment. This tables lists the following data for each line: <ul style="list-style-type: none"> • site name, if the line is remote • line equipment number • party of the assigned directory number • ringing code assigned to the directory lines • directory number • signal type • index into the line attribute (LINEATTR) table • list of options Refer to Note.
LENFEAT	Line feature. Lists the features assigned to a line in table LENLINES. Refer to Note.
SCGRP	Scan group. Lists the location of the scan groups that provide SC points for line features.
<p>Note: Use SERVORD to enter data for this table. This document does not provide a procedure or example of how to enter this table through SERVORD. Refer to the SERVORD section for an example of how to use SERVORD to enter data for this table.</p>	

SCM-100 Software for AccessNode (continued)

Datafill requirements for SCM-100 Software for AccessNode (Sheet 4 of 4)

Table	Purpose of table
SDGRP	Signal distributor group. Lists the location of the SD groups that provide SD points for line features.
LTDS	Line test desk signal distribution. Identifies the SD point that drives the applique circuit during the mechanized loop testing.
MTAMDRVE	Metallic test access minibar driver. Specifies the location of the metallic test access (MTA).
MTAVERT	Metallic test access vertical connection. Identifies the vertical connection to the MTA matrix.
MTAHORIZ	Metallic test access horizontal connection. Lists the assignment to a horizontal and horizontal group of metallic test access minibar drivers (MTAM).
AMAOPTS	The AMA options. Controls the activation and scheduling of the recording options for automatic message accounting (AMA).
RESFEAT	Residential line feature. Contains the assignment of custom local area signaling services (CLASS) features for residential lines. Refer to Note.
RESOFC	Residential line CLASS office data. Contains data for CLASS features. Refer to Note.
TEXTPHRS	Test phrases. Contains the text phrases that the customer premise equipment (CPE) displays.
TEXTLOG	Logical display text. This table contains the logical names of the text phrases.
SOFTKEY	The SOFTKEY. Specifies SOFTKEY information for application services.
DCSWDTYP	Deluxe spontaneous call waiting identification (DSCWID) type. Defines DSCWID treatment of subscriber lines.
<p>Note: Use SERVORD to enter data for this table. This document does not provide a procedure or example of how to enter this table through SERVORD. Refer to the SERVORD section for an example of how to use SERVORD to enter data for this table.</p>	

Datafilling table CLLI

Common language location identifier (CLLI) codes identify the far end of the following:

- announcements
- tones
- trunk groups

SCM-100 Software for AccessNode (continued)

- test trunks
- national milliwatt test lines
- service circuits

Datafill for SCM-100 Software for AccessNode for table CLLI appears in the following table. The fields that apply to SCM-100 Software for AccessNode appear in this table.

Datafilling table CLLI (Sheet 1 of 2)

Field	Subfield or refinement	Entry	Explanation and action
CLLI		refer to subfields	Common language location identifier. This field contains 16 characters. This field identifies the far end of the following: <ul style="list-style-type: none"> • announcements • tones • trunk groups • test trunks • national milliwatt test lines • service circuits
	PLACE	alphanumeric	Place. This four-character code identifies the name of the city at the far end of each group.
	PROV	alphanumeric	Province or state. This two-character code identifies the province or state at the far end of the trunk group.
	BLDG	alphanumeric	Building. This two-character code identifies the building number at the far end of the trunk group.
	TRAFUNIT	alphanumeric	Traffic unit. This three-character code identifies the destination of the traffic unit at the far end of the trunk group.
	SUFIX	alphanumeric	Suffix. This one-character code identifies trunk groups that terminate at the same CLLI location.
<p>Note 1: The SIZE field in table data size (DATASIZE) allocates memory for the entry with field DATSKEY equal to CLLI.</p> <p>Note 2: The maximum number of CLLI codes is 8192.</p>			

SCM-100 Software for AccessNode (continued)

Datafilling table CLLI (Sheet 2 of 2)

Field	Subfield or refinement	Entry	Explanation and action
ADNUM		0 to a number one less than the size of table CLLI shown in table DATASIZE.	Administrative trunk group number. Enter a number from 0 to a number one less than the size of table CLLI that appears in table DATASIZE. The value must be different.
TRKGRSIZ		0 to 2047	Trunk group size. This four-character field is equal to the maximum quantity of trunk members to be assigned to the trunk group.
ADMININF		refer to subfields	Administrative information. The operating company uses this 32-character field to record administrative information. The switching unit does not use the information in this field. The recommended subfields are TRAFCLS, OFFCLS, and TRKGRYP.
	TRAFCLS	alphanumeric	Trunk group traffic class. This field is optional input for administrative purposes only.
	OFFCLS	alphanumeric	Office class. This field is optional input for administrative purposes only.
	TRKGRYP	alphanumeric	Trunk group type. This field is optional input for administrative purposes only.
<p>Note 1: The SIZE field in table data size (DATASIZE) allocates memory for the entry with field DATSKEY equal to CLLI.</p> <p>Note 2: The maximum number of CLLI codes is 8192.</p>			

Datafill example for table CLLI

Sample datafill for table CLLI appears in the following example.

MAP example for table CLLI

CLLI	ADNUM	TRKGRSIZ	ADMININF
MTADRIVER	250	32	METALLIC_TEST_ACCESS_DRIVER
MONTALK	254	32	VERIFICATION
MJACK	257	256	METALLIC_JACK
MTU	259	32	METALLIC_TEST_UNIT

SCM-100 Software for AccessNode (continued)**Datafilling table SITE**

Table SITE contains data for the switching unit. Table SITE contains data for remote locations that connect to the switching unit. Enter data in table SITE before the system can assign a LEN. Enter data in table SITE before you can enter a PM. Enter data in table SITE to allow the DMS switch to recognize the equipment.

The first entry in table SITE must be HOST for the host switching unit. The operating company defines the site names for the remote locations.

Datafill for SCM-100 Software for AccessNode for table SITE appears in the following table. The fields that apply to SCM-100 Software for AccessNode appear in this table.

Datafilling table SITE (Sheet 1 of 2)

Field	Subfield or refinement	Entry	Explanation and action
NAME		Host or alphanumeric	Site name. Enter the site name assigned to the remote switching unit. The first character must be a letter. Site names can be a maximum of four characters in length. You cannot use PM type names for site names. The first entry in this field is for the host switching unit.
LTDSN		00 to 99	The LEN test desk site number. Enter a two-digit number required to dial the site that appears under field NAME.
MODCOUNT		0	Module count. Enter zero.
OPVRCLLI		Ver90 or alphanumeric	Operator verification CLLI. Enter the CLLI the system assigns to the operator verification trunk group at the remote location.
Note: The system allocates memory for a maximum of 32 sites.			

SCM-100 Software for AccessNode (continued)

Datafilling table SITE (Sheet 2 of 2)

Field	Subfield or refinement	Entry	Explanation and action
ALMDATA		refer to subfields	Alarm data. This field is for remote locations only. This field contains the following subfields: <ul style="list-style-type: none"> • ALMTYPE • TMTYPE • TMNO • TMCKTNO • POINT • CONTMARK
	ALMTYPE	CR, MJ, MN, or blank	Alarm type. Enter the alarm type. This field is for remote locations. Leave the entry for the host switching unit blank.
	TMTYPE	RSM, RMM, or blank	Trunk module type. Enter the trunk module or remote service module type for the location of the miscellaneous signal distributor point assigned to the alarm. Leave the entry for the host switching unit blank.
	TMNO	0 to 99	Trunk module number. Enter the number assigned to the remote service module for the location of the miscellaneous signal distributor point assigned to the alarm. Leave the entry for the host switching unit blank.
	TMCKTNO	0 to 23	Trunk module circuit number. Enter the trunk module circuit on the remote service module for the location of the miscellaneous signal distributor point assigned to the alarm. Leave the entry for the host switching unit blank.
	POINT	0 to 6	Point. Enter the signal distributor point number in the trunk module circuit number assigned to the alarm. Leave the entry for the host switching unit blank.
	CONTMARK	+ or \$	Enter a plus sign (+) when additional data for the site is specified on the next record. Enter a dollar sign (\$) to terminate this vector.
<p>Note: The system allocates memory for a maximum of 32 sites.</p>			

SCM-100 Software for AccessNode (continued)**Datafill example for table SITE**

Sample datafill for table SITE appears in the following example.

MAP example for table SITE

NAME			
LTDSN	MODCOUNT	OPVRCLLI	ALMDATA

HOST			
00	4	VER90	\$

Datafilling table LTCINV

Table line trunk controller inventory (LTCINV) contains the inventory data for different PM types, which include the SMA2. Table LTCINV does not contain the inventory data for P-side link assignments addressed in table LTCPSINV.

Datafill for SCM-100 Software for AccessNode for table LTCINV appears in the following table. The fields that apply to SCM-100 Software for AccessNode appear in this table.

Datafilling table LTCINV (Sheet 1 of 6)

Field	Subfield or refinement	Entry	Explanation and action
LTCNAME		refer to subfields	Line trunk controller name. This field contains subfields XPMTYPE and XPMNO.
	XPMTYPE	SMA2	Peripheral module type. Enter the type of PM.
	XPMNO	0 to 127	Peripheral module number. The range is 0 to 127 because the SMA2 is part of the host office.
			Note: Operating company personnel can number the XPMs from 0 to 127 but the total number of tuples in tables LTCINV and LTCRINV combined cannot exceed 210 XPMs. The XPM types can be any combination of types accepted by the two tables.
Note: Memory is allocated as required to allow a maximum sum of 210 tuples in tables LTCINV and LTCRINV combined.			

SCM-100 Software for AccessNode (continued)

Datafilling table LTCINV (Sheet 2 of 6)

Field	Subfield or refinement	Entry	Explanation and action
ADNUM		0 to 4095	Administration number. The engineering and administrative data acquisition system uses this number for data collection (EADAS/DC). The subsystem uses the number to identify nodes in the DMS-100 Family switch. This number remains fixed over dump and restore.
FRTYPE		CMVI, MVIE or MVDD	Frame type. Enter the frame type location of the PM equipment. The frame type is CMVI for the cabinet version, MVIE for the frame version and MVDD for the multi-vendor double density version.
FRNO		0 to 511	Frame number. Enter the frame number of the SMA2.
SHPOS		06 or 34 for CMVI; 16 or 44 for MVIE 16, 30,44 or 58 for MVDD	Shelf position. Enter the position of the shelves on the frame above the floor level. Enter the position of the shelves in inches.
FLOOR		0 to 99	Floor. Enter the floor location of the PM equipment frame.
ROW		A to H, J to N, P to Z, AA to HH, JJ to NN, and PP to ZZ	Row. Enter the row on the floor location of the PM equipment frame.
FRPOS		0 to 99	Frame position. Enter the position in the row of the PM equipment frame.
EQPEC		alphanumeric	Equipment product engineering code. Enter the PEC of the PM.
LOAD		alphanumeric	Load name. Enter the eight character name given to the issue of PM software.
<p>Note: Memory is allocated as required to allow a maximum sum of 210 tuples in tables LTCINV and LTCRINV combined.</p>			

SCM-100 Software for AccessNode (continued)

Datafilling table LTCINV (Sheet 3 of 6)

Field	Subfield or refinement	Entry	Explanation and action
EXECTAB		refer to subfields	Executive table. This field contains subfields TRMTYPE, EXEC, and CONTMARK. Note: Make changes to fields with multiple entries in the PROMPT mode only.
	TRMTYPE	alphanumeric	Terminal type. Enter the type of terminal models to be used. Use POTS for regular lines. Use RMM_TERM for remote maintenance trunks. Use ABTRK for regular trunks. Use R1_TERM for DTC300 trunks. Use MX5X09 and M5X12 for Meridian 9 and 12 button sets.
	EXEC	alphanumeric	Executive programs. Enter the set of executive programs required for the PM specified in the TRMTYPE field.
	CONTMARK	+ or \$	Continuation mark. Enter a plus sign (+) when the vector continues on the next line. Otherwise, enter \$ to end the vector.
CSLNKTAB		refer to subfields	C-side link table. For switches equipped with the old junctored network (JNET), this field contains subfields NMPAIR, NMPORT and CONTMARK. Note: Make changes to fields with multiple entries in the PROMPT mode only. For switches with the enhanced network (ENET), this contains subfields ENSHLFL, ENSLOT, ENLINK, ENDS30 and CONTMARK.
	NMPAIR	0 to 31	Network module pair number. Enter the network link, which is the location of the assigned PM. The network link corresponds to the provisioned C-side links of the SMA2.
	NMPORT	0 to 63	Network port number. Enter the network port that corresponds to the preceding link.
Note: Memory is allocated as required to allow a maximum sum of 210 tuples in tables LTCINV and LTCRINV combined.			

SCM-100 Software for AccessNode (continued)

Datafilling table LTCINV (Sheet 4 of 6)

Field	Subfield or refinement	Entry	Explanation and action
	ENSHELF	0 to 7	The ENET shelf number. Enter the shelf number, which is the location of the assigned SMA2.
	ENSLOT	10 to 16, 25 to 32 or 13 to 19	The ENET slot number. Enter the crosspoint slot number, which is the location of the assigned PM. The slot number corresponds to the provisioned C-side links of the SMA2. For a SuperNode SE switching unit, enter a value between 13 and 19.
	ENLINK	0 to 18	The ENET link number. Enter the link on the crosspoint which is the location of the assigned SMA2. The link corresponds to the provisioned C-side links of the SMA2.
	ENDS30	0 to 15	The ENET DS30. This field defaults to 0 (zero) when the link is DS30.
	CONTMARK	+ or \$	Continuation mark. Enter a plus sign (+) when the vector continues on the next line. Enter a dollar sign (\$) to end the vector.
OPTCARD		alphanumeric	<p>Optional card. This entry is a vector of a maximum of ten entries. The EISP card resides in slot 4. The entry is ISP 4. The universal tone receiver (UTR) card resides in slots 6 and 7. The entry is UTR6 and UTR7. The CLASS modem resource (CMR) card resides in slot 5.</p> <p>Note: Make changes to fields with multiple entries in the PROMPT mode only.</p> <p>Enter the MSGMX76 HOST for the SMA2 platform. When you enter the MSGMX76 card, the system prompts for the MX76LOC described in subfield MX76LOC.</p> <p>Examples are ISP4, UTR6, and CMR5.</p>
	MX76LOC	HOST or REM	The NTMX76 location. If the card is on a host PM, enter HOST. The REM is not a correct entry. Any attempt to enter REM generates an error message on the screen and the system returns to the default of HOST.
<p>Note: Memory is allocated as required to allow a maximum sum of 210 tuples in tables LTCINV and LTCRINV combined.</p>			

SCM-100 Software for AccessNode (continued)

Datafilling table LTCINV (Sheet 5 of 6)

Field	Subfield or refinement	Entry	Explanation and action
	CMRLOAD	alphanumeric	The CLASS modem resource load. This entry is a vector of a maximum of eight characters. Enter the CMR software load.
CONTMARK		+ or \$	Continuation mark. Enter + when the vector continues on the next line. Enter \$ to end the vector.
TONESSET		NORTHAM	Tone set. Enter the tone set of the current switch.
PROCPEC		AX74AA	Processor equipment PECs. Each unit of the SMA2 requires one PEC. Enter the PEC for unit 0 first. The PEC entered for a unit must correspond to the minimum firmware capabilities in the processor complex of each unit. The PEC for the SMA2 is AX74AA.
E2LOAD		alphanumeric	Electrically erasable programmable read-only memory. Contains the eight character name of the load file that is in the NTAX74AA EEPROM.
OPTATTR		\$	Optional attribute. This vector is entered for digital terminal controller (DTC) PMs. Enter a \$ to end the vector.
PEC6X40		6X40 AC, AD, FA, or FB	The 6X40 equipment PEC. Enter the version to the 6X40 card in the peripheral. The default is 6X40AA. The system displays the value entered in error messages when the system detects a card that contains faults. Note: The NT6X40AD and NT6X40FB cards provide enhanced diagnostic capabilities. If PEC6X40 datafill is set to the NT6X40AC or NT6X40FA version of the card, the system does not initiate the new diagnostics capabilities. The CM treats the interface as NT6X40AC/NT6X40FA regardless of the card installed.
Note: Memory is allocated as required to allow a maximum sum of 210 tuples in tables LTCINV and LTCRINV combined.			

SCM-100 Software for AccessNode (continued)

Datafilling table LTCINV (Sheet 6 of 6)

Field	Subfield or refinement	Entry	Explanation and action
EXTINFO		refer to subfield	Extension shelf information for the CMVI and MVIE versions. The MVDD version does not support an extension shelf. This field contains subfield EXTSHELF.
	EXTSHELF	Y or N	Extension shelf. If the PM is a CPM-based host peripheral and contains an extension shelf, enter Y (yes) and enter the fields below. If these conditions do not apply, enter N (no). No other entry is required. The default value for this field is N.
	EXTFR TYP	CMVI, MVIE, or NIL	Extension frame type. Enter the type of frame that contains the extension shelf.
	EXTFRNO	0 to 511	Extension frame number. Enter the number of the frame that contains the extension shelf.
	EXTSHPOS	20 for CMVI 30 for MVIE	Extension shelf position number. Enter the extension shelf position number.
	EXTFLOOR	0 to 99	Extension shelf floor number. Enter the number of the floor where the extension shelf is.
	EXTROW	A-Z, AA-ZZ excluding I and O	Extension shelf row number. Enter the character that identifies the row with the extension shelf.
	EXTFRPOS	0 to 99	Extension shelf frame number. Enter the number that indicates the frame position that houses the shelf.
	EXTEQPEC	MX86AB	Extension shelf equipment PEC. Enter the extension shelf equipment PEC.
	EXTSIDE	L or R	Extension shelf side. Enter the extension shelf side L (left) or R (right).
<p>Note: Memory is allocated as required to allow a maximum sum of 210 tuples in tables LTCINV and LTCRINV combined.</p>			

Datafill example for table LTCINV

Sample datafill for table LTCINV appears in the following example.

SCM-100 Software for AccessNode (continued)**MAP example for table LTCINV**

```

LTCNAME
  ADNUM  FRTYPE  FRNO  SHPOS  FLOOR  ROW   FRPOS  EQPEC  LOAD
                                     EXECTAB
                                     CSLNKTAB
                                     OPTCARD
TONESET          PROCPEC    E2LOAD
                                     OPTATTR
PEC6X40          EXTINFO
-----
SMA2  0
      1000 CMVI  0   18      1   E   2 MX85AB XM281AZ
              (   POTS POTSEX) (  KEYSET KSETEX)$
              (0 47) (0 55) (1 47) (1 55) (0 62)(1 62)(0 5)(1 5)$
              (ISP4) (UTR6) (UTR7) (MSGMX76 HOST) (CMR5) (CMR07AI)$
NORTHAM  AX74AA  AX74AA AX74XE01  $
6X40FA   Y CMVI  0  3  2  A  22 MX86AB R

```

Datafilling table CARRMTC

Table carrier maintenance (CARRMTC) allows the DMS switch administration to enter the following information:

- maintenance control information in peripherals
- out-of-service (OOS) limits for alarms
- system return-to-service (RTS) occurrences

Table CARRMTC contains the attributes of DS-1 links. For example, DS-1 link attributes can include line coding and frame formats. Table CARRMTC contains maintenance control information.

A carrier maintains communication on links that connect the following:

- DMS peripherals to channel banks
- DMS peripherals to remote DMS peripherals
- remote-to-remote DMS peripherals

Table CARRMTC can contain a maximum of 16 entries for each type of peripheral that provides carrier links in the switch. Use these entries in field CARRIDX of table LTCPSINV when you enter carriers.

SCM-100 Software for AccessNode (continued)

The following checks are made between table CARRMTC and table LTCPSINV:

- When a carrier index (CARRIDX) contains entries in table LTCPSINV, an entry for the PM type must be present in table CARRMTC. In this situation, the SMA2 must be present in table CARRMTC.
- When entries are removed from table CARRMTC, carriers in table LTCPSINV cannot reference the removed entry. If carriers in table LTCPSINV reference the entry, the system rejects the deletion command.
- When an entry in table CARRMTC changes, the system checks table LTCPSINV to determine if in-service carriers reference the entry. If in-service carriers reference the entry, the system rejects the command. The system displays a list of in-service carriers.

The DMS switch automatically adds the first tuple for SMA2 to table CARRMTC during initial program load (IPL) or first restart after IPL. The DMS designates the entry as index 0. The entry contains the value DEFAULT in the TEMPLNM field, and default values for other fields.

This tuple is permanent. Only fields ES, SES and thresholds for frame and slip losses can change. Except for the default tuple, add the tuples manually. Add the tuples before you can refer to the tuples in table LTCPSINV.

The system deletes the tuples if the DS-1 carriers do not associate with the tuples. You can change tuples in table CARRMTC if the associated DS-1 carriers are manually-busy or offline.

SCM-100 Software for AccessNode (continued)

Datafill for SCM-100 Software for AccessNode for table CARRMTC appears in the following table. The fields that apply to SCM-100 Software for AccessNode appear in this table.

Datafilling table CARRMTC (Sheet 1 of 4)

Field	Subfield or refinement	Entry	Explanation and action
CSPMTYPE		SMA2	The C-side node PM type. Enter the PM type of the node on the C-side of the carrier link.
TMPLTNM		Default	Template name. Enter the template name for the PM. The template name can be a maximum of 16 characters. This entry also appears in the field CARRIDX of table LTCPSINV. The default value is DEFAULT. Note: To activate values in fields BEROL and BERML enter NO_YELLOW_ALM.
RTSML		0 to 255	Return to service maintenance limit. Enter the number of times in the audit interval that the system can return a carrier to service. The number represents the number of times this action can occur before the system issues a warning. Value 255 disables this feature.
RTSOL		0 to 255	Return to service out-of-service limit. Enter the number of times in the audit interval that the system can return a carrier to service. The number represents the number of times this action can occur before the system places the carrier permanently OOS. Value 255 disables this feature.
CONTMARK		+	Continuation mark. Enter + to continue the record on the next line.
ATTR		refer to subfield	Attribute. This field contains subfield SELECTOR.
	SELECTOR	DS-1	Selector. Enter carrier type DS-1.

SCM-100 Software for AccessNode (continued)

Datafilling table CARRMTC (Sheet 2 of 4)

Field	Subfield or refinement	Entry	Explanation and action
	CARD	NTMX81AA	Card. Enter the product engineering code (PEC) of the DS-1 interface card used. The PEC for the DS-1 interface card in the SMA2 is NTMX81AA. The NTMX81AA provides 64 kbps clear-channel capability required for MBS services that operate in B8ZS mode.
	VOICELAW	MU_LAW	Voice law. Enter the voice law that the carrier uses. The carrier normally uses A_LAW for international switches. The carrier normally uses MU_LAW for North American switches.
	FF	ESF	Frame format. Enter extended superframe format (ESF) in this field. The SMA2-RDT subsystem uses a format that has 24-frames.
	ZLG	ZCS or B8ZS	Zero logic. Enter ZCS for zero code suppression. The system transmits a byte of zeroes with the number one in the least important bit position. This transmission contains faults. This byte produces a transmission that contains faults. This transmission is for the data in the SMA2-RDT subsystem. This transmission causes minor noise for speech. The ZCS precludes the use of integrated services digital network (ISDN). Enter B8ZS for bipolar 8-bit zero replacement. The 64 kb/s clear-channel capability for ISDN services requires the B8ZS.
	BERB	BPV or CRC	Bit error rate base. Enter CRC for cyclic redundancy check problems. The BER calculations are based on CRCs. The BER calculations detect problems on the DS-1 path. Enter BPV for bipolar violations. The BER calculations are based on BpVs. The BER calculations detect problems on the last DS-1 line in the path.
	DLK	NILDL	Data link. At this time, the system only supports NILDL.

SCM-100 Software for AccessNode (continued)

Datafilling table CARRMTC (Sheet 3 of 4)

Field	Subfield or refinement	Entry	Explanation and action
	IAT	N	Inhibit alarm transmit. Enter N for the IAT field for the SMA2-RDT configuration.
	LCGAST	250	Local carrier group alarm set threshold. Enter value for the threshold in units of 10 ms. The normal entry is 250. The range is 0 to 9999.
	LCGACL	1000	Local carrier group alarm clear threshold. Enter value for the threshold in units of 10 ms. The normal entry is 1000. The range is 0 to 9999.
	RCGAST	50	Remote carrier group alarm set threshold. Enter value for the threshold in units of 10 ms. The system multiplies entry by 10. This field contains 50. This field provides a threshold value of 500ms. This value overrides datafill. The range is 0 to 9999.
	RCGACL	50	Remote carrier group alarm clear threshold. Enter value for the threshold in units of 10 ms. The system multiplies the entry by 10. The system sets this field at 50. The system provides a threshold value of 500 ms. This value overrides datafill. The range is 0 to 9999.
	AISST	1 to 9999	Alarm indication signal set threshold. Enter value for the threshold in units of 10 ms.
	AISCL	1 to 9999	Alarm indication signal clear threshold. Enter value for the threshold in units of 10 ms. The range is 1 to 9999.
	BEROL	3 to 6	Bit error rate out-of-service limit. Enter the bit error rate out-of-service (OOS) limit. The limit is the negative of the exponent of 10 (10E-n). For example, 3 represents a 1 in 1000 bit error rate. Note: If you enter field TEMPLTNM as DEFAULT, the system sets this value to 3 and overrides the entry. If you enter field TEMPLTNM as NO_YELLOW_ALM, this value is user-controlled for any value in the range.

SCM-100 Software for AccessNode (continued)

Datafilling table CARRMTC (Sheet 4 of 4)

Field	Subfield or refinement	Entry	Explanation and action
	BERML	4 to 7	Bit error rate maintenance limit. Enter the bit error rate maintenance limit. The limit is the negative of the exponent of 10 (10E-n). Note: If you enter field TMPLTNM as DEFAULT, the system sets this value to 6 and overrides the entry. If you enter field TMPLTNM as NO_YELLOW_ALM, this value is user-controlled for any value in the range.
	ES	0 to 9999	Error second threshold. Enter value for the threshold in units of 10 ms.
	SES	0 to 9999	Severe error second threshold. Enter value for the threshold in units of 10 ms.
	FRAMEML	0 to 9999	Frame maintenance limit. Enter the maintenance limit for frame loss.
	FRAMEOL	0 to 9999	Frame loss limit. Enter the out-of-service limit for frame loss. The FRAMEOL must be larger than FRAMEML.
	SLIPML	0 to 9999	Slip maintenance limit. Enter the maintenance limit for slip.
	SLIPOL	0 to 9999	Slip out-of-service limit. Enter the out-of-service limit for slip. The SLIPOL must be larger than SLIPML.

BpV handling

Bipolar violation (BpV) levels for the RDT are hard-coded in SMA2 software. The BpV level is a 1 in 1000 bit error rate (1E-3), for the OOS limit. The BpV level is 1E-6 for the maintenance (MTC) limit.

When you enter field TMPLTNM as DEFAULT, the system compares RDT BpV levels with the hard-coded values. The system compares the levels to determine if the system must raise an alarm.

The RDT BpV levels are user-controllable when you enter field TMPLTNM as NO_YELLOW_ALM. When this event occurs, the system compares RDT BPV levels with the values in fields BEROL and BERML. The system compares the levels to determine if the system must raise an alarm.

SCM-100 Software for AccessNode (continued)**Datafill example for table CARRMTC**

Sample datafill for table CARRMTC appears in the following example.

MAP example for table CARRMTC

CSPMTYPE	TMPLTNM	RTSML	RTSOL	ATTR												
SMA2	DEFAULT	255	255	DS1	NTMX81AA	MU_LAW	ESF	B8ZS	BPV	NILDL						
				N	250	1000	50	50	150	1000	3	6	864	100		
					17	511	4	255								

Datafilling table PMLOADS

Table PMLOADS stores the device location of each PM loadfile. The XPM automatic loading feature can locate load files without intervention from operating company personnel.

Table PMLOADS lists the active and backup loadfiles. The system uses the active loadfile as the default load with the LOADPM command and most system activities. The system uses the backup loadfile when a problem occurs. The problem can occur during a load or an RTS of the active loadfile. The backup loadfile is always the unpatched loadfile. Nortel ships the loadfile that is not patched. Use the active and backup loadfiles when you apply and remove patches.

Table PMLOADS stores data for:

- the name of the active loadfile. The system uses the loadfile as the default load with the LOADPM command and most system initiated activities
- the name of the backup loadfile. The system uses the backup loadfile when a problem occurs. A problem can occur during a load or an RTS of the active loadfile. The backup loadfile is always the unpatched loadfile. Nortel ships the loadfile with the SMA2.
- the file locations
- the update active loadfile field. This field indicates if the site wants the active field updated automatically. The feature allows the patched loadfile to load into the XPM the system requires a reload. The feature simplifies reload and recovery of the XPM. When loadfile patching is enabled, the system updates active file information through loadfile patching.

The system uses the active and backup files as part of loading and recovery.

SCM-100 Software for AccessNode (continued)

Enter XPM load files in table PMLOADS before you enter XPM load files in table LTCINV. Table LTCINV enforces this rule.

Note: An exception to this rule occurs during the first entry, and dump and restore. During these times, the system automatically enters tuples in table PMLOADS when you enter LTCINV tuples.

The following table shows the datafill specific to SCM-100 Software for AccessNode for table PMLOADS. Only those fields that apply directly to SCM-100 Software for AccessNode are shown.

Datafilling table PMLOADS

Field	Subfield or refinement	Entry	Explanation and action
LOADNAME		alphanumeric	Peripheral module load name. Enter the XPM load file name. The range is a maximum of eight characters.
ACTFILE		alphanumeric	Active load file name. The name of the active XPM loadfile. The loadfile can be the original loadfile or a patched loadfile (PPXL). Range is a maximum of 32 characters.
ACTVOL		alphanumeric	Active volume. Identifies the device that stores the active loadfile. Range is the set of disk drive unit (DDU) volumes and system load module (SLM) disks that are available to the CM or S00DXPM. Range is a maximum of 16 characters.
BKPFILE		alphanumeric	Backup load file name. Identifies the name of the backup XPM loadfile. The name must be the same name as the LOADNAME field. Range is a maximum of 32 characters
BKPVOL		alphanumeric	Backup volume. The device that stores the backup loadfile. The range is the set of DDU volumes and SLM disks available to the CM or S00DXPM. The range is a maximum of 16 characters.
UPDACT		alphanumeric	Update active filename. At this time the system does not use this field. The default value is N.

Datafill example for table PMLOADS

Sample datafill for table PMLOADS appears in the following example.

SCM-100 Software for AccessNode (continued)**MAP example for table PMLOADS**

LOADNAME	ACTFILE	ACTVOL	BKPFIL	BKPVOL	UPDACT
XM281AZ	XM281AZ_970805	S001DXPM	XM281AZ	S001DXPM	N

Datafilling table PMNODES

Table peripheral module nodes (PMNODES) is read-only. The CM uses the PMNODES to control XPM unit node tables. The system automatically enters table PMNODES when entries are added or changed in inventory tables. Table PMNODES contains an entry for subtending nodes of each XPM. The system updates fields to reflect CM control of configuration data tables (CDT) in the XPM nodes. As nodes are deleted, holes can appear in the table. Some holes cannot be filled. The system manages tuples in table PMNODES. The subtending nodes must have a higher index than the head node.

Datafilling table PMNODES (Sheet 1 of 3)

Field	Subfield or refinement	Entry	Explanation and action
TABKEY		0 to 4095 0 to 117	Table key. Use a space to separate the two-part key. This field identifies the location of the unit node table from the XPM. The first part is host external node number. The second part is internal index number. Examples: The first key of an LTC with an external node number of 25 is 25 1. The key of the first XPM that attaches to the LTC is 25 2.
EXTNDNUM		0 to 4095	External node number. External number that the CM assigns to the XPM identified in field TABKEY. Example: The first XPM in the example above is an RCC2 with an external node of 33. The system uses key 25 2 to reference the XPM external node 33 in the LTC node tuple. The RCC2 has a node tuple key of 33 1 to represent that node.
NODETYPE		alphanumeric	Node type of XPM. The generic type of PM node. Examples: LTC_NODE, RCC_NODE, LCM_NODE and RCS_NODE.

SCM-100 Software for AccessNode (continued)

Datafilling table PMNODES (Sheet 2 of 3)

Field	Subfield or refinement	Entry	Explanation and action
PMTYPE		alphanumeric	The PM type. The PM type assigned to the node. Examples: RCC2, LCME, SMSR, and LTC.
LEVEL		0 to 15	The PM level. The number of device levels the XPM node differs from the messaging host. The numbers start at level 0 for messaging (head) XPMs. Examples: An LCME at level 2, attaches to the RCC2 at level 1. The RCC2 that attaches to the HOST LTC at level 0. The same LCME is at level 1 of the RCC2 tuple at level 0.
MSGHOST		0 to 4095	Messaging host. External node responsible for the transfer messages to this node. A messaging host must be able to transfer messages. Examples: LTC and RCC. Examples of XPMs that cannot be a messaging host are: RCU and SMSR.
PHYSHOST		0 to 4095	Physical host. External node that attaches to the XPM node. Example: The LCME attaches to RCC2 at external node 33.
PORTS		0 to 127	Number of ports. Total number of P-side ports in the host that this XPM node requires.
STPORT		0 to 255	Starting port. First P-side port in the host that this XPM node uses.
TERMS		0 to 4095	Number of terminals. Total number of terminals in the host that this XPM node requires.
STTERM		0 to 8675	Starting terminal. First terminal in the HOST that this XPM node uses.
PROTOCOL		alphanumeric	Message protocol. Type of message protocol the host uses to node links. Examples: MDS30, MDMSX, MHDLC.
MS		M or S	Master or slave. Enter M if this node contains the master clock.
IPML		Y or N	Inter-peripheral message link (IPML). Enter Y if this node is part of an IPML.

SCM-100 Software for AccessNode (continued)

Datafilling table PMNODES (Sheet 3 of 3)

Field	Subfield or refinement	Entry	Explanation and action
MODE		T or P	Table entry mode. Use terminal (T) or port (P) indexing to make entries in the table.
SLLCON		Y or N	Site line load control. Enter Y if this node is at a site that uses Essential Line Service Protection (ESP) or other site line load control features.
NT6X28		N	Uses NT6X28 card. Enter Y if this XPM uses the NT6X28 card. The NT6X28 signaling interface card is for the International Digital Trunk Controller (IDTC). Always enter N.
LCMLGMEM		Y or N	The LCM large memory. Enter Y if this XPM is an LCM with large memory (256k bytes).
RSVPORTS		Y or N	Reserved ports. Enter Y if this XPM messaging ports. The system reserves the ports for messaging.
RSVTERMS		Y or N	Reserved terminals. Enter Y if this XPM has terminals reserved for messaging.
MATENODE		Y or N	Mate node. Enter Y if this node is part of a dual configuration.
PACKED		Y or N	Packed internal tables. Enter Y if internal node tables are packed on this node. Before this feature the system compressed the node table when the XPM was RTS with the NODATASYNC option. Compression occurs when the CM takes both unit OOS and loads both units.
SUPPCDM		Y Y	Support configuration data table (CDT). Enter Y for each unit if the system supports CDT management.
CMINCTRL		Y or N	CM node control. Y if the node is under CM controls the node.

Datafill example for table PMNODES

Datafill for an SMA2 node with an RDT node that connects to the SMA2 appears in the following examples.

SCM-100 Software for AccessNode (continued)

MAP example for table PMNODES (SMA2 tuple)

Table: PMNODES											
TABKEY	EXTNDNUM	NODETYPE		PMTYPE	LEVEL	MSGHOST	PHYSHOST	PORTS			
33	1	33	LTC_NODE	SMA2	0	33	33	16			
STPORT	TERMS	STTERM	PROTOCOL	MS	IPML	MODE	SLLCON	NT6X28	LCMLGMEM	RSVPORTS	
0	641	1	MDMSX	S	N	P	N	N	N	Y	
RSVTERMS	MATENODE	PACKED	SUPPCDT	CMINCTRL							
Y	N	Y	YY	Y							

MAP example for table PMNODES (SMA2 to IDT tuple)

Table: PMNODES											
TABKEY	EXTNDNUM	NODETYPE		PMTYPE	LEVEL	MSGHOST	PHYSHOST	PORTS			
33	2	74	IDT_NODE	IDT	1	33	33	48			
STPORT	TERMS	STTERM	PROTOCOL	MS	IPML	MODE	SLLCON	NT6X28	LCMLGMEM	RSVPORTS	
18	641	642	MDMSX	S	N	P	N	N	Y	N	
RSVTERMS	MATENODE	PACKED	SUPPCDT	CMINCTRL							
N	N	Y	YY	Y							

Note: Each SMA2 node in the link that can message contains a tuple in table PMNODES to address the IDT.

Datafilling table LTCPSINV

The line trunk controller P-side link inventory (LTCPSINV) table lists the PM type and number for each bay that associates with the SMA2. Table LTCPSINV lists the port identification of the P-side links for each bay that associates with the SMA2 unit. The following capacities apply when you enter SMA2:

- The SMA2 provides a maximum of 54 P-side ports. The system uses these ports to define the flexible group of DS-1 and the EDCH services. The index of the LTCPSINV table is equal to the index for table LTCINV. The system automatically adds a SMA2 default tuple to LTCPSINV table when you enter a SMA2 in LTCINV table. When table LTCINV contains an extension shelf, you can enter the DS-1 links in the extension shelf.
- The SMA2 supports a maximum of 2 EDCH cards without the extension shelf. Enter the EDCH cards on P-side ports 9 and 17. When the extension shelf contains entries, the SMA2 supports a maximum of 6 EDCH cards. The 6 EDCH cards are entered on P-side ports 9, 17, and 40-47 or 43-45 and 47-51. There are 10 EDCH ports available. A maximum of 6 EDCH ports are available (5 active, 1 spare). Ports 48 through 51 are reserved for the 48 DS-1 + 4 EDCH cards configuration. Use ports 48 through 51 only

SCM-100 Software for AccessNode (continued)

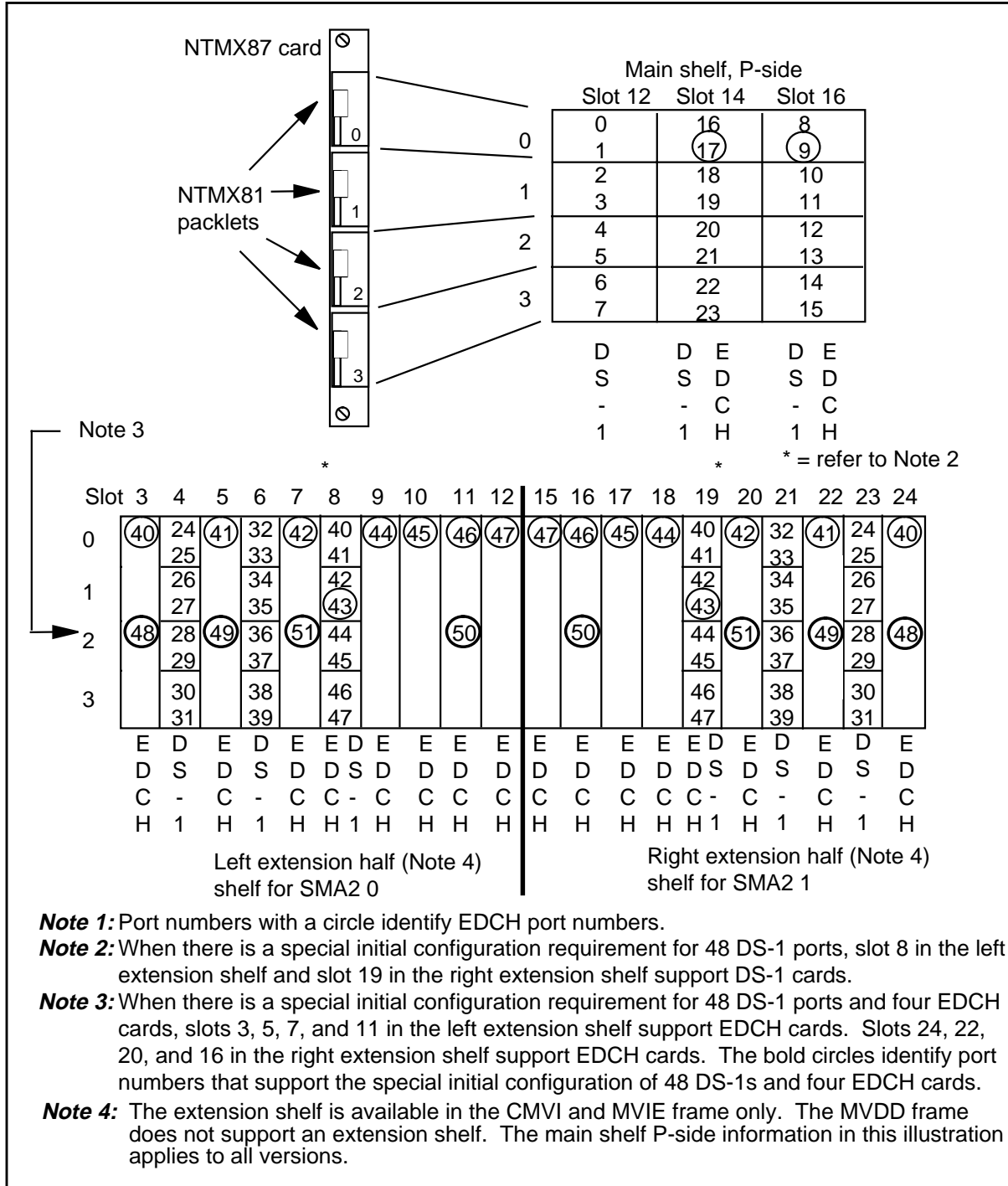
for a special initial requirement. Upgrades to this configuration are not supported because upgrades affect service.

- The SMA2 supports a maximum of 24 DS-1 links without the extension shelf. The SMA2 supports a maximum of 48 DS-1 links with the extension shelf.

The locations of the EDCH and DS-1 cards and the P-side links that connect to the cards appear in the following figure.

SCM-100 Software for AccessNode (continued)

P-side port provisioning



SCM-100 Software for AccessNode (continued)

Datafill for SCM-100 Software for AccessNode for table LTCPSINV appears in the following table. The fields that apply to SCM-100 Software for AccessNode appear in this table.

Datafilling table LTCPSINV (Sheet 1 of 2)

Field	Subfield or refinement	Entry	Explanation and action
LTCNAME		refer to subfields	Line trunk controller name. This field contains subfields XPMTYPE and XPMNO.
	XPMTYPE	SMA2	Peripheral module type. Enter the type of PM. This entry must match the entry in LTCINV.
	XPMNO	0 to 255	Peripheral module number. Note: Operating company personnel can number the XPMs from 0 to 255 but the total number of tuples in tables LTCINV and LTCRINV combined cannot exceed 210 XPMs. The XPM types can be any combination of types accepted by the two tables.
PSLNKTAB		refer to subfields	P-side link table. This field contains the following subfields: <ul style="list-style-type: none"> • EXP_PSIDES • PSLINK • PSDATA • AREASELCT • CARRIDX • ACTION • CONTMARK Vector from 0 to 53. Note: Make changes to fields with multiple entries in the PROMPT mode only.
	EXP_PSIDES	Y or N	Expanded P-sides platform indicator. If the shelf supports more than 20 P-side links, enter Y (yes). Enter field EXP_TAB. Enter N (no) if the shelf supports a maximum of 20 P-side links.
Note: Memory is allocated as required to allow a maximum sum of 210 tuples in tables LTCINV and LTCRINV combined.			

SCM-100 Software for AccessNode (continued)

Datafilling table LTCPSINV (Sheet 2 of 2)

Field	Subfield or refinement	Entry	Explanation and action
	EXP_TAB	Vector of a maximum of 54 multiples. Refer to explanation.	Expansion table. This field contains subfields PSLINK and PSDATA. If EXP_PSIDES is Y, this entry is a vector with a maximum of 54 multiples. Refer to subfields. If ESP_PSIDES is N, this entry is a vector with a maximum of 20 multiples. Refer to subfields.
	PSLINK	0-53	P-side link. Enter the P-side port number.
	PSDATA	refer to subfield	The P-side data. This field contains subfield AREASELCT.
	AREASELCT	DS1	Area select. The system enters the DS1 for DS-1 type interface cards.
	CARRIDX	DEFAULT	Carrier index. Enter the same value for the template name in table CARRMTC. The default value is DEFAULT. The value entered can be any value added in table CARRMTC. You must add all names in table CARRMTC before the names are available. You must add all names, other than DEFAULT, manually or you can use the datafill group.
	ACTION	Y or N	Action. Enter Y if the system removes the carrier from service. Use carrier removal when the system exceeds the OOS limit for frame, slip, errored-second, or severe errored-second. For another event, enter N.
	CONTMARK	+ or \$	Continuation mark. Enter + when the vector continues on the next line. Enter \$ to end the vector.

Note: Memory is allocated as required to allow a maximum sum of 210 tuples in tables LTCINV and LTCRINV combined.

Datafill example for table LTCPSINV

Sample datafill for table LTCPSINV appears in the following example.

SCM-100 Software for AccessNode (continued)**MAP example for table LTCPSINV**

LTCNAME	PSLNKTAB

SMA2	0
Y	(0 DS1 DEFAULT N) (1 DS1 DEFAULT N) (2 DS1 DEFAULT N)
	(3 DS1 DEFAULT N) (4 DS1 DEFAULT N) (5 DS1 DEFAULT N)
	(6 DS1 DEFAULT N) (7 DS1 DEFAULT N) (8 DS1 DEFAULT N)
	(9 DCH) (10 DS1 DEFAULT N) (11 DS1 DEFAULT N) (12 DS1
	DEFAULT N) (13 DS1 DEFAULT N) (14 DS1 DEFAULT N) (15 DS1
	DEFAULT N) (16 DS1 DEFAULT N) (17 DCH) (18 DS1 DEFAULT N)
	(19 DS1 DEFAULT N) (20 DS1 DEFAULT N) (21 DS1 DEFAULT N)
	(22 DS1 DEFAULT N) (23 DS1 DEFAULT N) (24 DS1 DEFAULT N)
	(25 DS1 DEFAULT N) (26 DS1 DEFAULT N) (27 DS1 DEFAULT N)
	(28 DS1 DEFAULT N) (29 DS1 DEFAULT N) (30 DS1 DEFAULT N)
	(31 DS1 DEFAULT N) (32 DS1 DEFAULT N) (33 DS1 DEFAULT N)
	(34 DS1 DEFAULT N) (35 DS1 DEFAULT N) (36 DS1 DEFAULT N)
	(37 DS1 DEFAULT N) (38 DS1 DEFAULT N) (39 DS1 DEFAULT N)
	(40 DCH) (41 DCH) (42 DCH) (43 NILTYPE) (44 NILTYPE)
	(45 NILTYPE) (46 NILTYPE) (47 NILTYPE) (48 NILTYPE)
	(49 NILTYPE) (50 NILTYPE) (51 NILTYPE) (52 NILTYPE)
	(53 NILTYPE) \$

Datafilling table ALMSCGRP

The alarm scan group (ALMSCGRP) table records the circuit equipment, location, and type of circuit card that contains scan points.

Datafill for SCM-100 Software for AccessNode for table ALMSCGRP appears in the following table. The fields that apply to SCM-100 Software for AccessNode appear in this table.

Datafilling table ALMSCGRP (Sheet 1 of 2)

Field	Subfield or refinement	Entry	Explanation and action
SCGROUP		0 to 255	Scan group. Enter the scan group number.
TMTYPE		alphanumeric	Trunk module type. Enter the type of trunk module, where the circuit is mounted.
TMNO		0 to 255	Trunk module number. Enter the number of the trunk module, where the circuit is mounted.

SCM-100 Software for AccessNode (continued)

Datafilling table ALMSCGRP (Sheet 2 of 2)

Field	Subfield or refinement	Entry	Explanation and action
TMCKTNO		0 to 23	Trunk module circuit number. Enter the trunk module circuit number, which is the assignment of the circuit .
CARDCODE		alphanumeric	Card code. Enter the PEC of the alarm card.

Datafill example for table ALMSCGRP

Sample datafill for table ALMSCGRP appears in the following example.

MAP example for table ALMSCGRP

SCGROUP	TMTYPE	TMNO	TMCKTNO	CARDCODE
0	MTM	1	1	3X82AA
1	MTM	3	1	3X82AA
2	MTM	1	7	3X84AA
3	MTM	1	10	0X10AA
.
15	RSM	1	7	0X10AA
.
21	RMM	2	11	0X10AA

Datafilling table ALMSDGRP

Table alarm signal distributor group (ALMSDGRP) records the circuit equipment, location and type of circuit card that contains signal distributor points.

Datafill for SCM-100 Software for AccessNode for table ALMSDGRP appears in the following table. The fields that apply to SCM-100 Software for AccessNode appear in this table.

Datafilling table ALMSDGRP (Sheet 1 of 2)

Field	Subfield or refinement	Entry	Explanation and action
SDGRP		0 to 255	Signal distributor group. Enter the signal distributor group number.
TMTYPE		alphanumeric	Trunk module type. Enter the type of trunk module, which is the location of the circuit.

SCM-100 Software for AccessNode (continued)**Datafilling table ALMSDGRP (Sheet 2 of 2)**

Field	Subfield or refinement	Entry	Explanation and action
TMNO		0 to 255	Trunk module number. Enter the number of the trunk module, which is the location of the circuit.
TMCKTNO		0 to 23	Trunk module circuit number. Enter the trunk module circuit number, which is the assignment of the the circuit.
CARDCODE		alphanumeric	Card code. Enter the PEC of the alarm card.

Datafill example for table ALMSDGRP

Sample datafill for table ALMSDGRP appears in the following example.

MAP example for table ALMSDGRP

SDGROUP	TMTYPE	TMNO	TMCKTNO	CARDCODE
0	MTM	1	0	3X82AA
1	MTM	3	0	3X82AA
2	MTM	1	6	3X84AA
4	MTM	1	4	2X57AA
5	MTM	1	5	2X57AA
6	MTM	1	18	2X57AA
7	MTM	1	19	2X57AA
8	MTM	6	18	2X57AA
9	MTM	6	19	2X57AA
10	MTM	9	18	2X57AA
11	MTM	9	19	2X57AA
.
22	MTM	12	18	2X57AA
23	MTM	12	19	2X57AA

Datafilling table ALMSC

The alarm scan (ALMSC) table associates a scan point function with an actual scan point. This table specifies the SD points must operate when the scan point is also active.

The LOGIC field for the RDTALRMCO SC point function must be Y. This indicates that the a fixed functionality in the software. The functionality is not entered.

Enter the SCGROUPs in table ALMSCGRP before you enter scan points. The value for field SCGROUP must be 4 or higher. The numbers 1 through 3 are

SCM-100 Software for AccessNode (continued)

reserved for DMS system scan alarms. These alarms include the common audible fail and office alarm unit fail.

Datafill for SCM-100 Software for AccessNode for table ALMSC appears in the following table. The fields that apply to SCM-100 Software for AccessNode appear in this table.

Datafilling table ALMSC (Sheet 1 of 2)

Field	Subfield or refinement	Entry	Explanation and action
FUNCTION		alphanumeric	Function. Enter the alarm function.
SCGROUP		0 to 255	Scan group. Enter the scan group where the scan point belongs.
POINT		0 to 6	Scan point. Enter the scan point number in the scan group.
NORMALST		0 to 1	Normal state. Enter the normal state of the scan point. Entry values are 0, when the scan point is normally off or open. Entry values are 1, when the scan point is normally on or closed.
REPORT		Y or N	Report. Enter Y to log an alarm report. For no log, enter N.
ALM		CR, MJ, MN or NA	Alarm. Enter the type of alarm to activate. The entry values are as follows: <ul style="list-style-type: none"> • CR (critical alarm) • MJ (major alarm) • MN (minor alarm) • NA (no alarm)
LOGIC		refer to subfields	Logic. This field contains the following subfields: <ul style="list-style-type: none"> • LOGIC • SDFUNCT • ALMGRP • ALMXFR • CONTMARK
	LOGIC	Y or N	Logic. Enter Y if the logic associated with the function is fixed. If the logic is not fixed, enter N.

SCM-100 Software for AccessNode (continued)**Datafilling table ALMSC (Sheet 2 of 2)**

Field	Subfield or refinement	Entry	Explanation and action
	SDFUNCT	alphanumeric	Signal distributor function. Enter the signal distributor function or functions that associate with the specified scan point.
	ALMGRP	Y or N	Alarm grouping. Enter Y if the system implements the alarm function when the alarm grouping key is active. Enter N if the system implements the alarm function continuously without the alarm grouping key.
	ALMXFR	Y or N	Alarm transfer. Enter Y if the system implements the alarm function when the alarm transfer key is active. For other conditions, enter N.
	CONTMARK	+ or \$	Continuation mark. When the record is different from the last record for a scan point, enter +. The + indicates that the next record specifies additional data for the scan point. When the record is the last for a scan point, enter a dollar sign (\$).

Datafill example for table ALMSC

Sample datafill for table ALMSC appears in the following example.

MAP example for table ALMSC

FUNCTION	SCGROUP	POINT	NORMALST	REPORT	ALM	LOGIC
RDTALRMCO	4	1	0	N	NA	Y \$

Datafilling table ALMSD

Table alarm signal distributor point (ALMSD) associates a SD point function with an actual SD point. The 13 SD point functions are available. Eight of the functions indicate when the RDT raises an alarm. Three of the functions indicate how important the alarm is that the RDT raises.

A one-to-one relationship is present between the eight functions and the eight possible enumerated "Which SD" SD points. The "Which SD" SD points are in the SDPOINTS field of table RDTINV.

SCM-100 Software for AccessNode (continued)

The AUDIBLE field must contain an N for the SD points that associate with the RDT alarms. The table control system enforces this requirement. A Y in this field indicates an audible alarm cutoff switch turns the SD points off. A Y must not be in this field for RDT SD points.

Enter the SDGROUPS in table ALMSDGRP before you enter SD points. The value for field SDGROUP must be 4 or higher. Values 1 through 3 are reserved for DMS switch alarms like alarm battery MTM fail.

The SD points are electrical relays. The DMS switch software controls SD points. The relays normally connect to lights, bells, or remote telemetry monitoring devices. To activate SD points in response to RDT alarms, enter the severity-indicating SD points in table ALMSD.

The SD points that indicate severity are as follows:

- RDTCRIT—operates when critical alarms are present at a RDT
- RDTMAJOR—operates when major alarms are present at a RDT
- RDTMINOR—operates when minor alarms are present at a RDT

The RDT alarm handling software uses eight SD point functions called Which-RDT SD point functions. The RDT uses the functions to indicate the RDT that has an alarm. The Which-RDT SD point functions are RDTSD1 through RDTSD8.

The SD points indicate the RDT that has an alarm. To set each RDT to activate a group of SD points, enter the group in field SDPOINTS in table RDTINV.

Two additional SD point functions are available, RDTACO and RDTWARN. When RDTACO is active, RDTACO indicates that active RDT alarms are present that do not appear. The system does not display the active RDT alarms because the alarm cutoff function is enabled.

Software alarm RDTWRN activates RDTWARN. The RDTWRN is like software alarms RDTCRT, RDTMJ, and RDTMN. The system automatically enters RDTWARN in table SFWALARM during the first program load. The system sets RDTWARN to activate on default.

After you enter RDTWARN, you cannot delete RDTWARN, from table ALMSD unless you remove RDTWARN from the logic of table SFWALARM. The RDTWARN indicates warning-level alarms at the RDT.

SCM-100 Software for AccessNode (continued)

The RDTWARN is like RDT SD points that indicate severity: RDTCRIT, RDTMAJOR and RDTMINOR.

Note: The RDTACO and RDTWARN functions are optional. You do not have to enter RDTACO and RDTWARN before you enter SD points in table RDTINV.

You can enter SD points RDTACO and RDTWARN if circuits on SD circuit cards NT2X57 are present.

Datafill for SCM-100 Software for AccessNode for table ALMSD appears in the following table. The fields that apply to SCM-100 Software for AccessNode appear in this table.

Datafilling table ALMSD (Sheet 1 of 2)

Field	Subfield or refinement	Entry	Explanation and action
FUNCTION		alphanumeric	Function. Enter the alarm function. The entry is alphanumeric with a maximum of 16 characters. The RDTACO and RDTWARN are new functions.
SDGROUP		0 to 255	Signal distributor group. Enter the signal distributor group where the SD point belongs. For SD points RDTACO and RDTWARN, SDGROUP must be 4 or higher. The 0-3 are reserved for system alarms.
POINT		0 to 7	Signal distributor point. Enter the SD point number in the signal distributor group.
NORMALST		0 to 1	Normal state. Enter the normal state of the SD point. Entry values are 0 if the SD point is OFF, or open, normally. Entry values are 1 if the SD point is ON, or CLOSED, normally. For RDTACO and RDTWARN SD points, 0 is correct.

SCM-100 Software for AccessNode (continued)

Datafilling table ALMSD (Sheet 2 of 2)

Field	Subfield or refinement	Entry	Explanation and action
AUDIBLE		Y or N	Audible. Enter Y if operation of the audible alarm reset key resets the signal distributor point. If the key does not reset the signal distributor point, enter N. The RDTACO and RDTWARN SD points cannot be audible. Only N is acceptable for these values.
LAMPTEST		Y or N	Lamp test. Enter Y to include the SD point in the lamp test. To exclude the SD point from the test, enter N.

Datafill example for table ALMSD

Sample datafill for table ALMSD appears in the following example.

MAP example for table ALMSD

FUNCTION	SDGROUP	POINT	NORMALST	AUDIBLE	LAMPTEST
RDTSD1	4	1	0	N	Y
RDTSD2	4	2	0	N	Y
RDTSD8	4	3	0	N	Y
RDTACO	4	4	0	N	Y
RDTWARN	4	5	0	N	Y

Datafilling table DCHINV

The D-channel handler inventory (DCHINV) table contains information about enhanced D-channel handlers provisioned in the SMA2. The DCHINV describes the physical, service and channel allocation characteristics of enhanced D-channel handlers. The inventory information includes the following:

- the DCH identification number
- type and number of the host PM
- product equipment code of the DCH
- load file name of the DCH
- port for the DCH used

SCM-100 Software for AccessNode (continued)

Datafill for SCM-100 Software for AccessNode for table DCHINV appears in the following table. The fields that apply to SCM-100 Software for AccessNode appear in this table.

Datafilling table DCHINV

Field	Subfield or refinement	Entry	Explanation and action
DCHNO		0 to 255	The D-channel handler number. Enter the external identification number that the system uses to represent a specified D-channel handler.
PMTYPE		SMA2	Peripheral module type. Enter the PM type, which is the location of the DCH.
PMNO		0 to 255	Peripheral module number. Enter the PM number of the SMA2. The SMA2 holds the DCH.
DCHPEC		NTBX02BA	The DCH product engineering code. Enter the PEC of the DCH card. For SMA2, enter NTBX02BA.
LOAD		alphanumeric	Load file name. Enter the DCH load name.
PORT		0 to 63	The DS1 port. Enter the DS-1 port number that the DCH uses.

Datafill example for table DCHINV

Sample datafill for table DCHINV appears in the following example.

MAP example for table DCHINV

DCHNO	PMTYPE	PMNO	DCHPEC	LOAD	PORT
0	SMA2	0	BX02BA	EDH81AZ	9
1	SMA2	0	BX02BA	EDH81AZ	17

Datafilling table ISGDEF

The ISDN service group definition (ISGDEF) table contains information on ISG numbers, the PM type, the services provided, and the allocation of services channels.

SCM-100 Software for AccessNode (continued)

Datafill for SCM-100 Software for AccessNode for table ISGDEF appear in the following table. The fields that apply to SCM-100 Software for AccessNode appear in this table.

Datafilling table ISGDEF (Sheet 1 of 2)

Field	Subfield or refinement	Entry	Explanation and action
ISGNO		0 to 255	The ISDN service group number. Enter the identification number that assigns the D-channel to a DCH.
PMTYPE		SMA2	Peripheral module type. Enter the PM. This PM supports DCH services.
PMNO		0 to 255	Peripheral module number. Enter the PM number of the SMA2. The SMA2 holds the DCH.
SERVICE		BRA or PD	Enter the services that the ISDN service group provides. A maximum of three entries are allowed. Use a \$ sign to terminate this field if you enter less than three entries.
CHNLTAB		refer to subfields	<p>Channel information. This field is a vector with a maximum of 32 entries. The entries specify the functions of each channel. This field contains subfields DCHNL and CHNLTYPE. Use a dollar sign (\$) sign to terminate this field if you enter less than 32 entries.</p> <p>Note: Assign all BD channels in descending order starting at 31. Assign BRA channels in ascending order. Start at 0. The order of entry for BD and BRA channels has the following limits:</p> <p>For one night process (ONP), the system displays the warning message "BD channels must be higher than any BRA channels". The message informs operating company personnel of the incorrect data order in the transferred tuple. The table on the new side accepts the tuple.</p> <p>For no ONP, the system displays the error message "BD channels must be higher than any BRA channels". The message informs operating company personnel of the incorrect data order in the tuple. The operating company personnel reject the tuple.</p>

SCM-100 Software for AccessNode (continued)**Datafilling table ISGDEF (Sheet 2 of 2)**

Field	Subfield or refinement	Entry	Explanation and action
	DCHNL	0 to 31	D-channel. Enter the external identifier for the D-channel.
	CHTYPE	refer to subfield	Channel type. This field contains subfield CHNLTYPE and refinements.
	CHNL-TYPE	NIL, RESERVED, BRA or BD	Channel type. Enter the service the D-channel provides.

Datafill example for table ISGDEF

Sample datafill for table ISGDEF appears in the following example.

MAP example for table ISGDEF

```

ISGNO  PMYTPE  PMNO  SERVICE  D_CHNL  CH_TYPE
-----
3      SMA2    5      BRA      PD$
(0 RESERVED) (1 BRA) (2 BRA) (3 BRA) (4 BRA) (5 BRA)
(6 BRA) (7 BRA) (8 BRA) (9 BRA) (10 BRA) (11 BRA)
(12 BRA) (13 BRA) (14 BRA) (15 BRA) (16 BRA) (17 BRA)
(18 BRA) (19 BRA) (20 BRA) (21 BRA) (22 BRA) (23 BRA)
(24 BRA) (25 BRA) (26 BRA) (27 BRA) (28 BRA) (29 BRA)
(30 BD) (31 BD) $

```

Datafilling table LTGRP

Table logical terminal group (LTGRP) defines a maximum of 32 logical terminal groups. The system defines a group for ISDN. This group is permanent.

You can define other group names in alpha-numeric groups of eight characters. A group can support a maximum of 1022 logical terminal identifiers. Tables can contain a maximum of 32 704 logical terminal identifiers (32 x 1022).

Note: Enter a logical terminal group in this table before logical terminals are specified in other tables.

SCM-100 Software for AccessNode (continued)

Datafill for SCM-100 Software for AccessNode for table LTGRP appears in the following table. The fields that apply to SCM-100 Software for AccessNode appear in this table.

Datafilling table LTGRP

Field	Subfield or refinement	Entry	Explanation and action
GROUP		alphanumeric	Logical terminal group. Enter the name of the logical group of terminals.
GROUPNO		0 to 31	Group number. Enter a number that corresponds to the group name. The default number for logical terminal group ISDN is 0. For data packet network terminal groups, enter a number between 1 to 15.
OPTIONS		SAPI16 or \$	Options. Enter SAPI16 for packet or circuit-switched terminals. If the SAPI16 option is not specified, you cannot enter packet-switched terminals for the group.

Datafill example for table LTGRP

Sample datafill for table LTGRP appears in the following example.

MAP example for table LTGRP

GROUP	GROUPNO	OPTIONS
ISDN	0	(SAPI16)
SMA2	1	(SAPI16)

Datafilling table LTDEF

Table logical terminal definition (LTDEF) defines logical terminals and terminal access privileges. A logical terminal can contain the following access privileges:

- voice and circuit-switched data on a B-channel (B)
- low-speed packet-switched data on a D-channel (D)
- high-speed packet data on a B-channel (PB)
- combined circuit-switched and D-channel packet data (BD)
- a 2-B circuit switching (2B)

SCM-100 Software for AccessNode (continued)

Datafill for SCM-100 Software for AccessNode for table LTDEF appears in the following table. The fields that apply to SCM-100 Software for AccessNode appear in this table.

Datafilling table LTDEF (Sheet 1 of 3)

Field	Subfield or refinement	Entry	Explanation and action
LTKEY		refer to subfields	Logical terminal key.
	LTGRP	alphanumeric	Logical terminal group. Enter the logical terminal group. The group ISDN is known.
	LTNUM	0 to 1022	Logical terminal number. Enter a logical terminal number.
LTAP		B, D, BD, PB, 2B	<p>Logical terminal access privilege. Enter one of the following access privileges:</p> <ul style="list-style-type: none"> • B for circuit-switching • D for D-channel packet-switching • BD for combined circuit-switching and D-channel packet-switching • PB for B-channel packet switching • 2B for 2B circuit switching <p>Note: Use BD for functional sets. Use B for ISDN Meridian feature transparency (MFT).</p>
CLASSREF		BRAFS, or BRAMFT	Logical terminal class of service. Enter a set of services allowed for the logical terminal. The range is BRAFS for BRA functional sets. The range is BRAMFT for functional terminals.

SCM-100 Software for AccessNode (continued)

Datafilling table LTDEF (Sheet 2 of 3)

Field	Subfield or refinement	Entry	Explanation and action
	OPTION	refer to list of options	<p>This field contains a list of options. The options are assigned based on the value given to the field LTCLASS.</p> <p>The BRAFS options are:</p> <ul style="list-style-type: none"> • NOVOICE • NOVBD • NOCMD • NOPMD • DTEI • SPIDSFX • EKTS • PVC • UATEI • CACH • DEFLTERM • UNATEI <p>The BRAMFT options are:</p> <ul style="list-style-type: none"> • BRAMFT • DTEI • SPIDSFX • PVC
		CACH	<p>Call appearance handling feature. Enter CACH to enable CACH. Enter EKTS if you enter this option.</p>
		EKTS	<p>Electronic key telephone service. Enter EKTS to indicate electronic key telephone service.</p>
		NOCMD	<p>No circuit mode data calls. Enter NOCMD if circuit mode data calls are not allowed.</p>

SCM-100 Software for AccessNode (continued)

Datafilling table LTDEF (Sheet 3 of 3)

Field	Subfield or refinement	Entry	Explanation and action
		DEFLTERM	Default logical terminal. If a phone has a default service profile, and does not require the system to download a service profile, enter DEFLTERM. For example, enter DEFLTERM for a non-initializing terminal.
		NOPMD	No packet mode data calls. Enter NOPMD if packet mode data calls are not allowed.
		NOVBD	No voice band data calls. Enter NOVBD if voice band data calls are not allowed.
		NOVOICE	No voice calls. Enter NOVOICE if voice calls are not allowed.
	SPIDSFX	refer to subfield	Service profile identifier suffix. This field contains subfield SPID_SUFFIX.
	SPID-SUFFIX	numeric	Service profile identifier suffix. Enter a name that identifies the subscriber on a terminal endpoint identifier (TEI) terminal.
		DTEI	Dynamic terminal endpoint identifier. Enter DTEI. This field requires an entry required if subfield SPIDSFX is entered.
	PVC	refer to subfields	Protocol version control. This field contains subfields VERSION and ISSUE.
	VERSION	FUNCTIONAL	Protocol version. Enter the protocol version.
	ISSUE	0 or 1	Protocol issue. Enter the protocol issue designated for the specified logical terminal. Enter 0 for stimulus and MFT protocols. Enter or 1 for BellCore functional protocol.
		UATEI	User-assigned terminal endpoint identifier. When this field appears, enter the dynamic user-assigned terminal endpoint identifier.

Datafill example for table LTDEF

Sample datafill for table LTDEF appears in the following example.

SCM-100 Software for AccessNode (continued)

MAP example for table LTDEF

LYKEY	LTAP	CLASSREF
SMA2	B	
BRAFS	(NOPMD)	(PVC FUNCTIONAL 0) \$

Datafilling table SPECCONN

Table special connection (SPECCONN) establishes special-service connections that require dedicated permanent connections through the DMS SuperNode switch. Software arranges and maintains special-service connections. Hard-wired connections do not arrange and maintain special-service connections. The software arranges the connection. The connection remains until operating company personnel removes the connection from table SPECCONN.

Datafill for SCM-100 Software for AccessNode for table SPECCONN appears in the following table. The fields that apply to SCM-100 Software for AccessNode appear in this table.

Datafilling table SPECCONN (Sheet 1 of 4)

Field	Subfield or refinement	Entry	Explanation and action
ENDPT1		refer to subfield	Endpoint 1. Subfield SCSEL specifies endpoint 1.
	SCSEL	DS1, ISLC or DCHCHNL	Special connection selector. Enter the type of selector for endpoints.
	DCHCHNL	refer to subfields	The DCH channel. Refer to subfields ISGNO and CHNL.
	ISGNO	0 to 255	D-channel handler number. Enter the D-channel handler identifier.
	CHNL	0 to 31	Channel number. Enter the D-channel on the D-channel handler.
	DS1	refer to subfields	The DS1. Refer to subfields PMTYPE, SMANO, SMACKTNO, and SMACKTTS.
	PMTYPE	SMA2	Peripheral module type. Enter the type of PM.
	SMA2NO	0 to 511	The SMA2 number. Enter the external number of the SMA2.

SCM-100 Software for AccessNode (continued)

Datafilling table SPECCONN (Sheet 2 of 4)

Field	Subfield or refinement	Entry	Explanation and action
	SMA2CKTNO	0 to 47	The SMA2 circuit number. Enter the P-side port number on the SMA2.
	SMA2CKTTS	1 to 24	The SMA2 time slot. Enter the time slot (channel) on the DS-1.
	ISLC	refer to subfields	The ISDN line card. Refer to subfields LEN and CHANNEL.
	LEN	refer to subfields	Line equipment number. This field contains the following subfields: SITE, RDTFRAME, RDTUNIT, RDTSHELF, and RDTSLLOT.
	SITE	alphanumeric	Site. Enter the location of the RDT a four-character alphanumeric. This entry is not optional. A default value is not assigned to this entry.
	RDT FRAME	0 to 511	The RDT frame. Enter the RDT frame number. The RDT frame is not a physical frame. The RDT frame is a software entity. The software entity represents the group the RDT belongs to at the site.
	RDT UNIT	0 to 9	The RDT unit. Enter the number that represents the RDT unit in the group.
	RDT SHELF	0 to 6	The RDT shelf. Enter the shelf number where the RDT resides. For GENTMC signaling, the range is from 0 to 6.
	RDT SLOT	1 to 99	The RDT slot. Enter the slot number where the RDT resides.
	CHNL	B1 or B2	Channel. Enter the ISDN line card channel.
ENDPT2		refer to subfield	Endpoint 2. Subfield SCSEL specifies Endpoint 2.
	SCSEL	DS1, ISLC or DCHCHNL	Special connection selector. Enter the type of selector for endpoints.
	DCHCHNL	refer to subfields	The DCH channel. Refer to subfields ISGNO and CHNL.

SCM-100 Software for AccessNode (continued)

Datafilling table SPECCONN (Sheet 3 of 4)

Field	Subfield or refinement	Entry	Explanation and action
	ISGNO	0 to 255	The D-channel handler-channel handler number. Enter the D-channel handler identifier.
	CHNL	0 to 31	Channel number. Enter the D-channel on the D-channel handler.
	DS1	refer to subfields	The DS1. Refer to subfields PMTYPE, SMANO, SMACKTNO, and SMACKTTS.
	PMTYPE	SMA2	Peripheral module type. Enter the type of PM.
	SMANO	0 to 511	The SMA2 number. Enter the external number of the SMA.
	SMACKTNO	0 to 53	The SMA2 circuit number. Enter the P-side port number on the SMA2.
	SMACKTTS	1 to 24	The SMA2 time slot. Enter the time slot (channel) on the DS-1.
	ISLC	refer to subfields	The ISDN line card. Refer to subfields LEN and CHANNEL.
	LEN	refer to subfields	Line equipment number. This field contains the following subfields: SITE, RDTFRAME, RDTUNIT, RDTSHELF, and RDTSLLOT.
	SITE	alphanumeric	Site. Enter the location of the RDT (four-character alphanumeric). This entry is not optional, and a default value is not assigned to the entry.
	RDT FRAME	0 to 511	The RDT frame. Enter the RDT frame number. The RDT frame is not a physical frame. The RDT frame is a software entity. The software entity represents the associated RDT group from the site.
	RDT UNIT	0 to 9	The RDT unit. Enter the number that represents the RDT unit in the group.
	RDT SHELF	0 to 6	The RDT shelf. Enter the shelf number where the RDT resides. For GENTMC signaling, the range is from 0 to 6.

SCM-100 Software for AccessNode (continued)**Datafilling table SPECCONN (Sheet 4 of 4)**

Field	Subfield or refinement	Entry	Explanation and action
	RDT SLOT	1 to 99	The RDT slot. Enter the slot number where the RDT resides.
	CHNL	B1 or B2	Channel. Enter the ISDN line card channel.
CONTYPE		CAB, CON, or PENDING	Connection type. Enter CAB for A-bit and B-bit signaling connected. Enter CON for connected or PENDING for pending.
STATUS		ACTIVE	Connection status. Enter the status of the connection.

Datafill example for table SPECCONN

Sample datafill for table SPECCONN appears in the following example.

MAP example for table SPECCONN

ENDPT1	ENDPT2	CONTYPE	STATUS
DCHCHNL 1 28 DS1 SMA2 0 0 1	CON	ACTIVE	
DCHCHNL 1 29 DS1 SMA2 0 0 2	CON	ACTIVE	
ISLC RDT1 1 0 0 16 B1 DS1 SMA2 0 1 9	CON	ACTIVE	
ISLC RDT1 1 0 0 18 B2 DS1 SMA2 0 1 10	CON	ACTIVE	

Datafilling table RDTINV

The remote digital terminal inventory (RDTINV) table contains inventory data in the DMS-100 switching office. Inventory data include RDTs and the IDTs that relate to the RDTs. This table also contains the C-side connection information and RDT configuration information.

Note: Remote digital terminal (RDT) is a common term. A type of RDT is the S/DMS AccessNode remote fiber terminal (RFT). In an integrated S/DMS AccessNode configuration, the term RDT means RFT.

The FCOT has 14 C-side links. If two DS-1 mapper cards are available, 28 C-side links are available. The SMA2 supports a maximum of 28 P-side links for each AccessNode. A maximum of eight RDTs can be connected with one SMA2.

SCM-100 Software for AccessNode (continued)

If ISDN is available, a maximum of five RDTs can be connected with one SMA2. When an RDT is added to table RDTINV, the DMS SuperNode switch software creates an associated IDT in the SMA2.

The deletion of an RDT from table RDTINV causes the associated IDT to disappear. Table RDTINV creates an RDT as a remote to the DMS SuperNode switch and defines the attributes of the RDT.

RFT line capacity changes

Issues that affect RFT line capacity changes Changes to other fields in table RDTINV are not allowed while changing the SHELFSLT field. If other changes to table RDTINV are attempted while SHELFSLT is being changed, an error message is displayed warning operating company personnel that field SHELFSLT cannot be changed while other fields are being changed.

Note: Before you change the line capacity of an RFT, enter the QUERYPM command at the IDT level to display the total number of lines allocated to an SMA2 and the number of lines on the posted IDT.

The SHELFSLT value is a four-digit number of which only the second is a variable. The other three digits are constants. If any attempt is made to change these values, a warning message displays.

Example of a MAP response

```
WARNING: minslot and minshelf are being changed to 1 and maxslot  
is being changed to 96.
```

How to increase the line capacity of an RFT Before you increase the line capacity of an RFT, the SMA2 that connects the RFT to the SuperNode switch must be put in the manually busy (ManB) state using the command string BSY PM FORCE. An attempt to increase the line capacity of an RFT in another state results in an error message being displayed that warns operating company personnel that the SMA2 must be ManB or Offl to change field SHELFSLT.

ATTENTION

When increasing the line capacity of an RFT using the command string BSY PM FORCE, conduct this activity during periods of low traffic. This is because active calls will be dropped and all RFTs connected to the SMA2 will be viewed as CBsy by the SuperNode switch.

SCM-100 Software for AccessNode (continued)

Before you increase the line capacity of an RFT, check that all DTA connections are released to change the size of the RFT. The line capacity of an RFT cannot be increased when DTA lines are equipped or connected. Refer to the procedure "How to release digital test access (DTA) connections" that follows to determine if DTA connections exist and how to release them.

Note: If DTA connections are not released, SMA2 P-side channels get "hung." These "hung" channels could result in a complete loss of call processing for the RFT that is to have the line capacity increased.

How to release digital test access (DTA) connections The following steps must be followed to determine if DTA connections exist on the RFT and to release DTA connections.

At a MAP terminal

- 1 Access the LTP level by typing
>MAPCI ;MTC ;LNS ;LTP
and pressing the Enter key.
- 2 Access the LTPDATA sublevel by typing
>LTPDATA
and pressing the Enter key.
- 3 Determine if DTA connections are equipped by typing
>EQUIP DTA QUERY ALL
and pressing the Enter key.

Example of a MAP response

```
MTR  EQUIP  US  DS  CONNECT  CHNL  STAT
-----
1  HOST  04  0  01  12  B1  B2
```

If any DTA equipment is reserved, an equipment number and line equipment number (LEN) will be listed under the MTR and EQUIP headings as seen in the previous example. If a DTA connection exists, a LEN will be listed under the CONNECT, CHNL, and STAT headings.

Perform steps 4 and 5 to release the DTA connection and reset the DTA equipment. If there are no DTA connections on the RFT, go to step 6.

- 4 To release the DTA equipment
>CONNECT eqno RLS
where eqno
is the equipment number given in response to the command string
EQUIP DTA QUERY ALL
- 5 To reset the DTA connection
>EQUIP DTA RESET eqno

SCM-100 Software for AccessNode (continued)

where eqno

is the equipment number given in response to the command string
EQUIP DTA QUERY ALL

Note: This step is only needed if DTA equipment is reserved and a connection does NOT exist. You must release the DTA connection before you reset the DTA equipment.

6 You have successfully completed this procedure.

Methods for changing the line capacity of an RFT In this section procedures for changing the line capacity of an RFT are given. There are two methods for increasing and one method for decreasing the line capacity of an RFT.

The two methods to increase the line capacity of an RFT:

- method 1 - use two MAP terminals
- method 2 - prepare a read (store) file. This store file is a compilation of all the actions in the first method. The read file is then executed as a single activity. This method eliminates the natural delays imposed by manually entering the commands.

Method 1 - use two MAP terminals Method 1 requires operating company personnel to control two MAP windows. It consists of the steps that follow.

Note: Operating company personnel should have both MAP terminals available and do as much pre-typing as possible to reduce the time it takes to increase the line capacity of an RFT. The pre-typing activity can be done in table RDTINV up to the point of adding the data given in steps 2 and 3 of method 1.

ATTENTION

Before you increase the line capacity of an RFT, verify that all DTA connections are released for the RFT to be resized. The line capacity of an RFT cannot be increased when DTA lines are equipped or connected. Refer to the procedure "How to release digital test access (DTA) connections" to determine if DTA connections exist and how to release them.

Perform the following steps to increase the line capacity of an RFT.

Note: Before you change the line capacity of an RFT, enter the QUERYPM command at the IDT level. You can use the QUERYPM command to

SCM-100 Software for AccessNode (continued)

display the total number of lines connected to an SMA2 and the number of lines on the posted IDT.

At MAP terminal 1

- 1 Post the SMA2 that connects to the RFT that is to have its line capacity increased by typing

```
>MAPCI;MTC;PM;POST SMA2 sma2_no
```

and pressing the Enter key.

where

sma2_no

is the number of the SMA2 to be posted

At MAP terminal 2

- 2 Position on the affected RFT in table RDTINV by typing

```
>TABLE RDTINV;FORMAT PACK;POS rdtname
```

and pressing the Enter key.

where

rdtname

consists of the site, frame, and unit number of the RFT datafilled in table RDTINV, for example, RFT1 0 0

- 3 Change the value of subfield SHELFSLT by typing

```
>CHA VARTYPE
```

and pressing the Enter key.

The following confirmation message appears

```
Enter Y to continue processing or N to quit.
```

If you wish to continue, respond to this message by typing

```
>Y
```

and pressing the Enter key.

Respond to the MAP terminal response as follows:

```
>RDTVAR
```

Press the Enter key.

```
>SHELFSLT
```

Respond to the MAP terminal response by entering the new SHELFSLT value

```
>newshelfslot value
```

and pressing the Enter key.

where

newshelfslot value

is the new RFT shelf size to be entered in table RDTINV, field SHELFSLT.

Note: You may respond to the request to confirm in order to verify that all DTA connections are released. If the system responds that DTA

SCM-100 Software for AccessNode (continued)

connections exist, respond by typing "N" to reject the request. Then proceed to the procedure "How to release digital test access (DTA) connections" earlier in this section. However, if the system responds that the SMA2 is InSv, proceed to step 4. Do not enter "Y" to confirm until directed to do so in step 5.

At MAP terminal 1

4

ATTENTION

Do not proceed to step 5 until both units are in the ManB state.

Busy the SMA2 by typing

>BSY PM FORCE

and pressing the Enter key.

The following confirmation message appears

This action will take this pm and all of its subtending nodes out of servicePlease confirm ("Yes", "Y", "No", or "N"):

If you wish to continue, respond to this message by typing

>Y

and pressing the Enter key.

Note: At this point the SMA2 is ManB and any calls that are active on RFTs are taken down and an outage occurs.

At MAP terminal 2

5

ATTENTION

Do not proceed to step 6 until the "Tuple changed" message is received at the MAP terminal.

Ensure step 4 at MAP terminal 1 is complete by noting that both units are ManB before proceeding with this step. Respond "Y" to confirm the change to SHELFSLT by typing

>Y

and pressing the Enter key.

At MAP terminal 1

6

Return to service the ManB SMA2 by typing

>RTS PM FORCE

and pressing the Enter key.

At this point the SMA2 returns to service and the state of the IDTs change from CBsy to InSv.

SCM-100 Software for AccessNode (continued)

7 You have successfully completed this procedure.

Method 2 - prepare a store file Method 2 requires operating company personnel to prepare a store file that contains the steps of method 1. The advantage of method 2 is that outage time is reduced by removing the delays associated with manually entering commands on two MAP terminals.

ATTENTION

Before you increase the line capacity of an RFT, verify that all DTA connections are released for the RFT to be resized. The line capacity of an RFT cannot be increased when DTA lines are equipped or connected. Refer to the procedure titled "How to release digital test access (DTA) connections" presented earlier in this section to determine if DTA connections exist and how to release them.

Note 1: If DTA connections are not released, SMA2 P-side channels get "hung." These "hung" channels could result in a complete loss of call processing for the RFT that is to have the line capacity increased.

Note 2: Before changing the line capacity of an RFT, enter the QUERYPM command at the IDT level to display the total number of lines connected to an SMA2 and the number of lines on the posted IDT.

Perform the following steps to create a store file used to increase the line capacity of an RFT:

At the CI level

- 1 Access the store file editor by typing
>Edit <filename>
and pressing the Enter key.
where
filename
is the name you choose for the store file.
- 2 Enter information into the store file by typing
>Input
and pressing the Enter key.

SCM-100 Software for AccessNode (continued)

3



CAUTION

Entering incorrect values may result in an outage longer than planned. When compiling this store file, ensure all values are correct and entered correctly. If incorrect values are entered, an outage of longer duration than planned could result.

- a Enter the content of the store file as follows:
 - i
 - ii **>MAPCI NODISP;MTC;PM;POST SMA2 sma2_no**
and press the Enter key.
where
sma2_no
is the number of the SMA2 connected to the RFT to be upsized.
 - iii **>BSY PM FORCE**
and press the Enter key. This command manually busies the SMA2.
 - iv **>Y**
and press the Enter key.
 - v **>TABLE RDTINV;FORMAT PACK;POS rdtname**
and press the Enter key.
where
rdtname
consists of the site, frame, and unit number of the RFT datafiled in table RDTINV, for example, RFT1 0 0
 - vi **>CHA VARTYPE**
and press the Enter key.
 - vii **>Y**
and press the Enter key.
 - viii Enter the existing value entered in field RDTVAR, for example
>RFT
and press the Enter key.
 - ix **>newshelfslot value**
where
newshelfslot value
is the new RFT shelf size to be entered in table RDTINV, field SHELFSLT.

SCM-100 Software for AccessNode (continued)

and press the Enter key.

- x Enter the response to the system confirmation message asking you to confirm the change to SHELFSLT as

>Y

and press the Enter key.

- xi **>QUIT**

and press the Enter key.

- xii **>ABORT**

and press the Enter key.

Enter the ABORT command to abort any system responses to incorrect data entry. The ABORT command prevents situations that may arise when the DMS switch prompts the user for correct data in response to incorrect data that was entered in the store file. Entering incorrect data prevents the SMA2 from returning to service and may prolong the planned outage.

- xiii **>RTS PM FORCE**

and press the Enter key. This command returns the SMA2 to service.

- xiv **>QUIT ALL**

- 4 After typing the information in step 3 as the store file, press the Enter key twice to stop editing the store file.

- 5 Save the store file by typing

>file SFDEV

and pressing the Enter key.

where

filename

is the name of the store file input in step 1.

- 6 List the store file by typing

>listsf

and pressing the Enter key. This command lists all the store files in the SFDEV the user created.

- 7

ATTENTION

When you activate the store file, the SMA2 is put in the ManB state. Any calls that are active on RFTs connected to the SMA2 are taken down and an outage occurs.

Therefore, conduct this activity during periods of low traffic.

Activate the store file to increase the line capacity of the RFT by typing

>read <filename>

and pressing the Enter key.

SCM-100 Software for AccessNode (continued)

where

filename

is the name of the store file to be activated.

This command runs the store file.

- 8 After the store file has run and the line capacity of the RFT was successfully increased, you may wish to delete the store file. Delete the store file by typing

```
>erasesf <filename>
```

and pressing the Enter key.

where

filename

is the name of the store file to be deleted.

- 9 You have successfully completed this procedure.

How to decrease the line capacity of an RFT If the line capacity of an RFT is being decreased, the SuperNode switch determines if any LENSs are present above the new (lowered) value datafilled in table RDTINV field SHELFSLT. If any LENSs are present above the new value, an error message displays informing operating company personnel that the line capacity of the RFT cannot be decreased because there are currently LENSs provisioned above the new provisioned value.

Decreasing the line capacity of an RFT is accomplished at one MAP terminal and no outage occurs. When decreasing the line capacity, table LNINV must be verified to ensure the required number of lines are deleted before allowing an update to table RDTINV, field SHELFSLT. Prior to deleting a tuple from table LNINV, the lines will be cleared from other tables such as IBNLINES, KSETLINE, KSETINV, LENLINES, and SPECCONN. Although table RDTLT will be updated after table LNINV, because of provisioning delays, tuples deleted from table LNINV may still be present in table RDTLT and will need to be checked.

Note: When decreasing the line capacity of an RFT, a decrease in the value of the SHELFSLT field in table RDTINV is allowed only after all LENSs that reside above the new (lowered) SHELFSLT value have been removed.

Perform the following procedure to decrease the line capacity of an RFT.

At the MAP terminal

- 1 Position on the affected RFT in table RDTINV by typing

```
>TABLE RDTINV;FORMAT PACK;POS rdtname
```

and pressing the Enter key.

where

SCM-100 Software for AccessNode (continued)**rdtname**

consists of the site, frame, and unit number of the RFT datafilled in table RDTINV, for example, RFT1 0 0

- 2 Change the value of subfield SHELFSLT by typing
>CHA VARTYPE
 and pressing the Enter key.
 The following confirmation message appears
 Enter Y to continue processing or N to quit.
 If you wish to continue, respond to this message by typing
>Y
 and pressing the Enter key.
 Respond to the MAP terminal response as follows:
>RDTVAR
 Press the Enter key.
>SHELFSLT
 Respond to the MAP terminal response by entering the new SHELFSLT value
>newshelfslot value
 and pressing the Enter key.
where
>newshelfslot value
 is the new RFT shelf size to be entered in table RDTINV, field SHELFSLT.
- 3 Confirm the new SHELFSLT entry into table RDTINV by typing
>Y
 and pressing the Enter key.
- 4 You have successfully completed this procedure.

Assigning DS-1 links in a multi-host environment

In a multi-host environment, each RFT network element can connect to a maximum of three S/DMS hosts. A host is a group of the office parameters OFFICE_CLLI_NAME and NETWORK_ELEMENT_ID in table OFCENG. These names and IDs must be different for each host.

**CAUTION****Loss of service**

For an IDLC, a data mismatch of DS-1 logical link numbers causes slow dial tone and loss of speech path.

SCM-100 Software for AccessNode (continued)

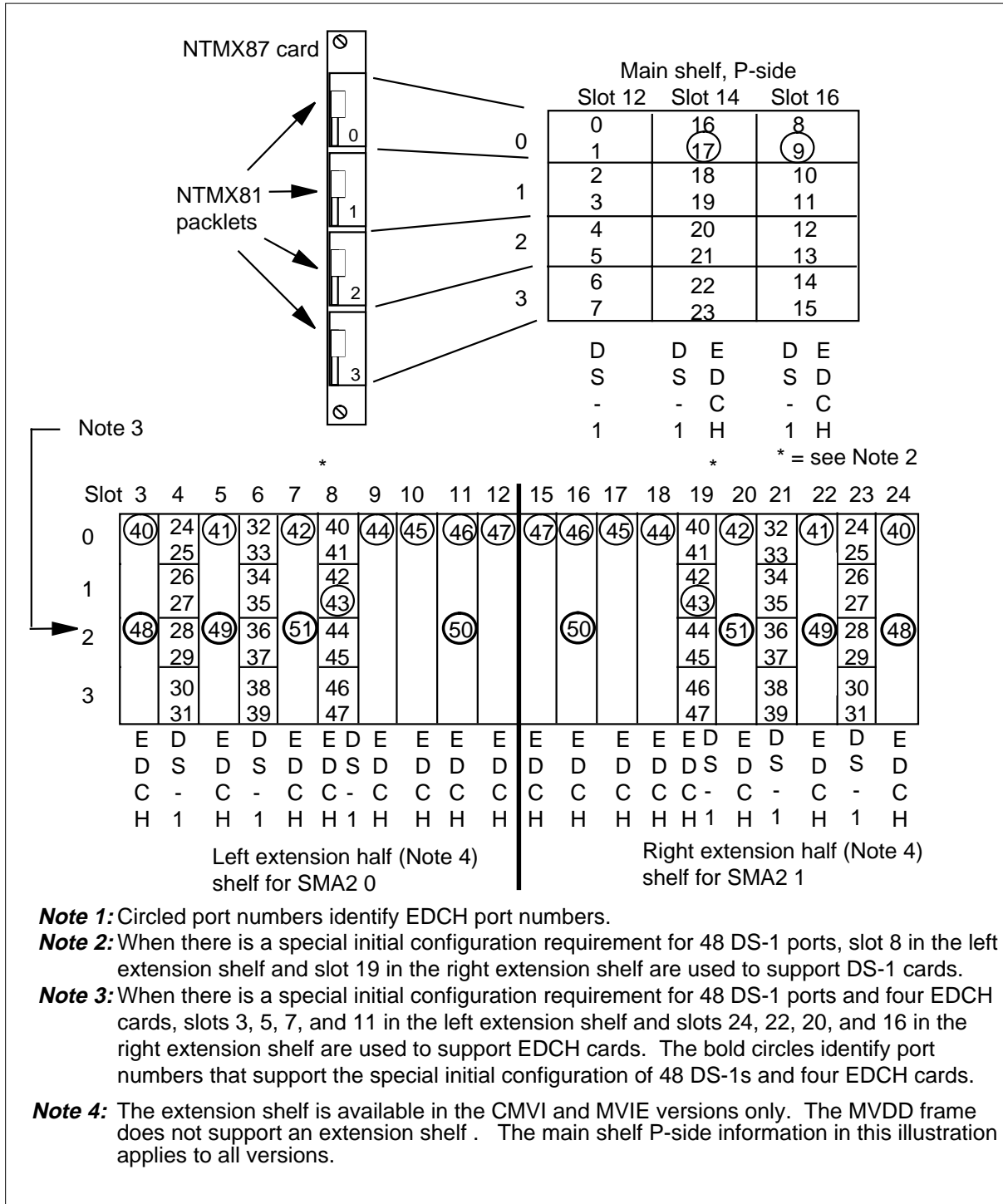
The entries in table RDTINV must be the same as the facility assignments for the network element in the operations controller (OPC). The first two links assigned to the host office automatically become logical links 1 and 2. These links carry the common signaling channel (CSC) and embedded operations channel (EOC) messaging.

Note: When RFTs are provisioned, consider how the DS-1 links are to map to the SMA2. To maintain reliability, the primary and secondary messaging links must be on separate NTMX81 and NTMX87 cards in the SMA2. From the RFTs point of view, the primary and secondary messaging links are hardcoded as C-side links 1 and 2.

The P-side port to associated card slot numbering scheme appears in the following figure. Use this figure to determine which DS-1 card slots and ports to choose as primary and secondary messaging link connections at the SMA2.

SCM-100 Software for AccessNode (continued)

P-side port numbering to card slot scheme



SCM-100 Software for AccessNode (continued)

To maintain switch services levels between the SMA2 and the RFT, the following numbers *must* be the same for each link:

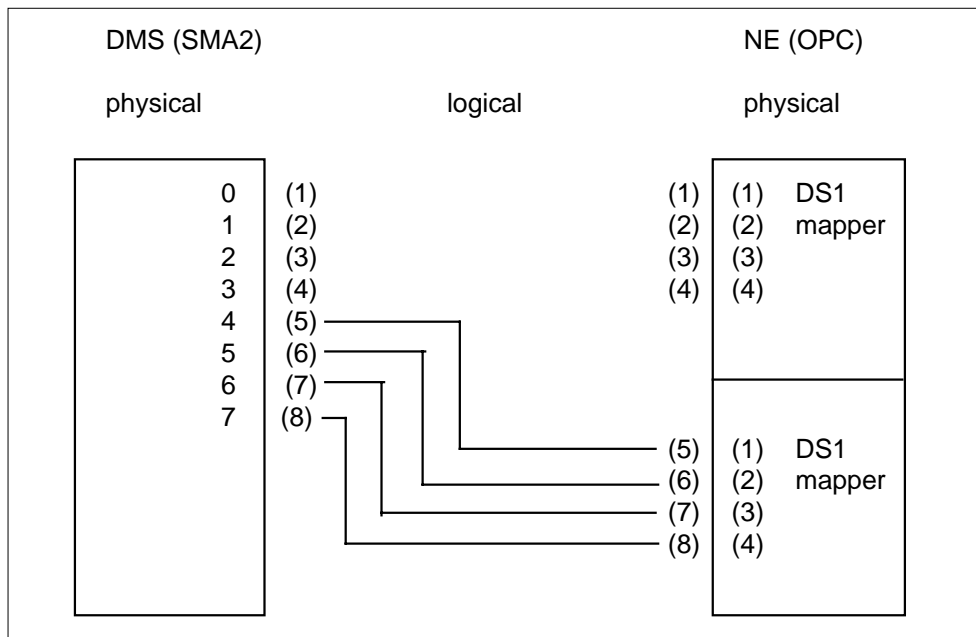
- the logical DS-1 link numbers in field LINKTAB
- the logical DS-1 link numbers for the network element in the OPC facility manager

The logical link numbers are from 1 to 28. The physical link numbers can be different. For the SMA2, the physical link numbers are 0 to 27.

For the network element, the physical link numbers are 1 to 14 for each DS-1 mapper card. See the following example for a diagram of physical to logical link assignments between the SMA2 and RFT.

Note: First entries and the changes that follow to SMA2 logical links must be reflected in the OPC facility.

Physical to logical link assignment



Use a different number for each FCOT and RFT network element. Use of network element numbers cannot occur again on a different SMA2 in the same switch.

Do *not* assign a network element number of 5, 05, 005 or 0005 to some types of network elements. A network element (FCOT or RFT) that connects an S/DMS SuperNode that runs at BCS35 or lower cannot have these numbers

SCM-100 Software for AccessNode (continued)

assigned. Network element 5 is the network element number for the associated S/DMS SuperNode in an IDLC configuration. Network element 5 cannot be provisioned in this product release.

The following figure is an example of FCOT and RDT numbers. The SMA2 0 has eight point-to-point systems with network elements numbered 1 through 16. The SMA2 1 has eight point to point systems with network elements numbered 17 through 32.

The FCOT and RFT network numbers

SMA2 0		
System number	FCOT number	RFT number
1	1	2
2	3	4
3	5	6
4	7	8
5	9	10
6	11	12
7	13	14
8	15	16
SMA2 1		
9	17	18
10	19	20
11	21	22
12	23	24
13	25	26
14	27	28
15	29	30
16	31	32

Engineering LAPD parameters

The link access procedure on the D-channel (LAPD) is a flow-control mechanism for the EOC and CSC. The LAPD contains a sliding window K. This window limits the number of leftover frames at one time. This window limits the receiver-not-ready (RNR) message the system can send from one peer to the other peer. This transfer indicates the sender cannot accept incoming data at this time.

Note: The SMA2 operates at highest efficiency level with the LAPD parameters at the default values of the parameter. Leave the parameters at the default values unless a specified reason is present to change a parameter.

SCM-100 Software for AccessNode (continued)

If the LAPD parameters require alteration, changes to the two parameters on both ends (RFT and DMS) must occur together. Use the guidelines in the following table. The values that appear are *default* values for the CSC and EOC.

Default LAPD parameters (Sheet 1 of 2)

Parameter	CSC	EOC	Description
K	7	7	<p>This number is the maximum number of leftover frames that are not acknowledged. The range is 1-128.</p> <p>This size is the LAPD window size. The LAPD state window must maintain a maximum of K messages in memory that wait for acknowledgment from the far end. A sharp increase in the value of K increases the use of resources in the enhanced ISP (EISP).</p> <p>The value of K can double for each RDT EOC link. This action cuts in half the number of EOCs (and RFT) the SMA2 supports.</p>
N200	3	3	<p>This number is the maximum number of frame retransmissions allowed. The range is 1-8.</p>
N201	52	256	<p>This number is the maximum number of octets allowed in the information field of an information frame. The range is 1-256.</p> <p>As N201 increases, the maximum message size increases. The amount of memory messages the LAPD protocol buffers use can also increase. The amount of increase depends on the real length of the messages on the link, not only the maximum length given for N201.</p> <p>For SMA2s that support MBS terminals, the N201 value must have a minimum value of 52 to support the MBS opcode messages. This value is the default when the RDT is an S/DMS AccessNode.</p>

SCM-100 Software for AccessNode (continued)**Default LAPD parameters (Sheet 2 of 2)**

Parameter	CSC	EOC	Description
T200	250 ms	250 ms	<p>This time is the maximum length of time in milliseconds (ms) a data link layer entity waits for acknowledgment (time-out) of a transmitted frame. The range is 100-250 ms.</p> <p>Changes in these values do not have an important impact. These changes have an impact when the LAPD link experiences link faults that cause message retransmissions.</p> <p>The LAPD implementation must queue potential outgoing messages when the LAPD attempts to transmit an earlier message again. To determine the time involved in a retransmission, multiply N200 by T200. When these values increase, the resources increase. These resources can maintain a link that experiences transmission problems.</p> <p>Because the LAPD links terminate on a SMA2, the links must share common resources in the EISP. The common resources can be a real-time process. This process reduces the resources available to maintain other LAPD links on the same SMA2. For SMA2s that support MBS lines, the T200 value must be a minimum of 25 to correspond to the N201 value.</p>
T203	30 s	30 s	<p>This time is the maximum time in seconds (s) allowed without an exchange of frames. The range is 10-250 s.</p> <p>To shorten this background timer increases the resources that maintain the backup links. Because the resources for this purpose are a small percentage of the whole, changes to this parameter do not normally cause a problem.</p>

If an IDT is offline, field RDTDN of a RFT tuple changes can occur if the changes are different between all RFT tuples. The following warning appears to caution operating company personnel.

**CAUTION****Use extreme caution when you change field RDTDN.**

This change causes loss of service on all lines on this IDT. Use of the REPROV command in the RDTPROV increase must occur after this change to restore service to the lines. Changes to field RDTDN must have associated changes to the distinguished name at the RDT. Failure to match these values prevents the establishment of a maintenance connection to a RDT.

SCM-100 Software for AccessNode (continued)

Provision all lines again on the RDT. Use the RDTPROV tool to perform this action. In the RDTPROV increase, REPROV <IDT_number> provisions the lines again.

To avoid potential entry problems:

- Always enter data in table RDTINV before you perform facility assignments in the OPC. This caution includes the addition, deletion or reassignment of DS-1 links.

Note: To change DS-1 assignments, busy and return-to-service the IDT.

- Assign consecutive logical link numbers in table RDTINV, when possible.
- Create a cross reference table. Tie the logical and physical link number assignments between the SMA2 from table RDTINV and the network element from the OPC facility manager.

The ILC Provisioning and RDTINV Table Control for IRTU provide table changes for the addition of the integrated remote test unit (IRTU) line card. Table additions also occur for the virtual IRTU line card for the S/DMS AccessNode. The fields that this feature has an effect on are in field MTSTACPT. Completion of field MTSTACPT and installation of the IRTU card activates IRTU access.

Deletion of fields TST_PT_ACC_TYPE and PT_CONNECTION_INFO occurs from table RDTINV. Addition of the following fields occurs to table RDTINV.

- TSTUTTYP
- TSTHDUSR (does not apply to ERTU)
- RTUNUM
- VERTID
- TSTACCPA
- ALTUSE

SCM-100 Software for AccessNode (continued)

Datafill for SCM-100 Software for AccessNode for table RDTINV appears in the following table. The fields that apply to SCM-100 Software for AccessNode appear in this table.

Datafilling table RDTINV (Sheet 1 of 12)

Field	Subfield or refinement	Entry	Explanation and action
RTDNAME		refer to subfields	The RDT name. This name is the key to this table. This name identifies the RDT to the system. This field contains subfields SITE, FRAME and UNIT.
	SITE	alphanumeric	Site. Enter the four-character site name of the remote location. This entry must appear in table SITE.
	FRAME	0-511	Frame. Enter the logical frame number.
	UNIT	0-9	Unit. Enter the logical unit number. Note: The unit number must be 0 for the IDT configured with EOC. When field EOC is entered as S or O, the UNIT number entered in field UNIT must be 0.
ADNUM		0-4095	Administration number. The Engineering and Administrative Data Acquisition System for Data Collection (EADAS/DC) uses this number to identify nodes in the DMS-100 Family switch. This number remains fixed over dump and restore.
IDTNAME		refer to subfields	The IDT name. This field identifies the SMA2 and the IDT where the RDT connects. This field contains subfields XPMTYPE, XPMNO and IDTNO. Note: The IDT must be offline to change this field.
	XPMTYPE	SMA2	The XMS-based peripheral module type. This field identifies the type of peripheral that connects to the RDT.
	XPMNO	0-127	The XPM number. This number identifies the SMA2 where the RDT connects.

SCM-100 Software for AccessNode (continued)

Datafilling table RDTINV (Sheet 2 of 12)

Field	Subfield or refinement	Entry	Explanation and action
	IDTNO	0-255	The IDT number. This number identifies the IDT where the RDT connects. Note: Do not delete the IDT if lines attach to the IDT.
NENAME		\$	The source identifier. The external operation support system uses this identifier to identify the RDT. The range is 1 to 20 characters. This field is always entered with a \$. This entry occurs because the system automatically enters the network element. The system takes the name supplied at the RDT HMI. If the NE name retrieved from the AccessNode has spaces, _ replaces the spaces.
PRIMOPC		1-20 characters	The primary OPC identifier. The range is 1-20 characters.
BACKOPC		1-20 characters	The backup OPC identifier. The range is 1-20 characters.
VARTYPE		refer to subfield	The variable type. Indicates the type of integrated digital loop carrier. The current carrier is the S/DMS AccessNode only. This field can also override the default LAPD parameters if the access vehicle uses a CSC that the AccessNode uses. Field VARTYPE contains subfield RDTVAR.
	RDTVAR	RFT	The RDT variable. Enter RFT for a RDT with NT proprietary extensions to the RDT signaling standards. Note: Changes to this field cannot occur. The tuple must be deleted and added again.

SCM-100 Software for AccessNode (continued)

Datafilling table RDTINV (Sheet 3 of 12)

Field	Subfield or refinement	Entry	Explanation and action
	SHELFSLT	refer to subfields	<p>Shelf slot. This slot is a vector that controls the maximum number of lines an RFT can contain. For the RFT, subfields MINSHELF, MAX_RDT_SLOT, MINSLOT, and MAX_RDT_SLOT determine this number.</p> <p>Note: Currently the AccessNode has a hardware limit of 1344 lines.</p> <p>Note: A typical value for SHELFSLT is 1 7 1 96 where 1 is MINSHELF, 7 is MAX_RDT_SHELF, 1 is MINSLOT, and 96 is MAX_RDT_SLOT. The MAX_RDT_SHELF field can be changed to control the RFT line capacity. The other three fields are constants and any attempt to change these fields results in a warning message.</p>
	MINSHELF	numeric (0 to 1)	Minimum shelf value. This subfield specifies the minimum allowable value for the shelf of a line equipment number (LEN). The only allowable value for AccessNode is 1.
	MAX_RDT_SHELF	numeric (0 to 31)	Maximum shelf value. This subfield identifies the maximum allowable value for the shelf of a LEN. The range is 0-31. For the RFT, this range is 1-31. The maximum value for AccessNode is 22.
	MINSLOT	numeric (0 to 1)	Minimum slot value. This subfield specifies the minimum allowable value for the slot of a LEN. The only allowable value for AccessNode is 1.
	MAX_RDT_SLOT	numeric (0 to 99)	<p>Maximum RDT slot value. This subfield specifies the maximum allowable value for the slot of a LEN. The only allowable value for AccessNode is 96.</p> <p>Note: For the last shelf, MAX_RDT_SLOT has a value of 32 because of the maximum line limit on RDTs/RFTs is 2048.</p>

SCM-100 Software for AccessNode (continued)

Datafilling table RDTINV (Sheet 4 of 12)

Field	Subfield or refinement	Entry	Explanation and action
CLAPDFLT		Y or N	Choose LAPD default. For the IDT, this field specifies if default or optional LAPD parameters are used. Enter Y (use default parameters) or N (define optional parameters). If N is the entry, subfield CLAPDPAR appears.
	CLAPDPAR	alphanumeric	Choose LAPD parameters. Specifies LAPD parameters that are not default. To enter the selected link access procedure, complete the refinements that appear in the following. Enter: <ul style="list-style-type: none"> • N201 and a number from 1-256 • N200 and a number from 1-8 • K and a number from 1-128 • T203 and a number from 10-250 • T200 and a number from 100-250

SCM-100 Software for AccessNode (continued)

Datafilling table RDTINV (Sheet 5 of 12)

Field	Subfield or refinement	Entry	Explanation and action
MTSTACPT		TBP, ERTU, IRTU or \$	<p>Metallic test access point. This point is the selector field that identifies types of metallic test access (MTA) points, configured on the RDT. The selector field includes</p> <ul style="list-style-type: none"> • TBP (test bypass pair) • ERTU (external remote test unit) • IRTU (integrated remote test unit) • \$ (for no entry, or stop) <p>Two different test heads can access the AccessNode at the same time. The following groups are possible:</p> <ul style="list-style-type: none"> • TBP separately. The MAP terminal and a test trunk (NTT) test is not available and is performed over the test bypass pair. • ERTU separately. Only NTT test is performed in the system. • IRTU separately. One or both test heads defined. Only one test head can be defined for NTT use. • TBP with ERTU. The TBP provides MAP terminal tests. The ERTU provides NTT tests. • IRTU and ERTU. One or both test heads defined. The IRTU defined as MAPIF. <p>Note: The TBP or IRTU provide the MAP terminal test. Use of the IRTU can occur with test bypass pair.</p>
TBP		refer to subfields	<p>Test bypass pair. This selector identifies the MTA point configured to supply metallic test bypass for MTM-based test heads. This selector also identifies NTT access that requires a horizontal cross-connect at the MTA. The MTA is the trunk circuit for the metallic line test equipment. This field contains subfields TSTHDUSR, VERTID and TSTACCPA.</p>

SCM-100 Software for AccessNode (continued)

Datafilling table RDTINV (Sheet 6 of 12)

Field	Subfield or refinement	Entry	Explanation and action
	TSTHDUSR	MAPIF, NTTIF or BOTH	Test head user. This field indicates which test system uses the test head. The test system can be MAP, NTT or BOTH.
	VERTID	0-1023	Vertical identifier. This field replaces the VERTID section of the original prompt PT_CONNECTION_INFO. This field represents the vertical in the MTA matrix where the control path is tied.
	TSTACCPA	TBPP	Test access path. This field replaces the MTAUID and MTAPTID section of the original prompt PT_CONNECTION_INFO. The TBPP is the required entry with an S/DMS Accessnode.
	SCSDUSED	Y or N	Scan point/signal distributor point used. Enter Y if SD/SD points are in use and provide the multiple that contains: <ul style="list-style-type: none"> • INHSCGRP—range of 0-511 • INHSCPT—range of 0-6 • INHSDGRP—range of 0-511 • INHSDPT—range of 0-6 For any other condition, enter N.
ERTU		refer to subfields	External remote test unit. This selector identifies an external metallic test head on the RDT, for NTT tests. This selector is compatible with the TBP selector. The TBP selector is for MAP terminal tests. This field contains subfields VERTID and TSTACCPA.
	VERTID	0-1023	Vertical identifier. This field replaces the VERTID section of the original prompt (PT_CONNECTION_INFO). This represents the vertical in the MTA matrix where the control path is tied.

SCM-100 Software for AccessNode (continued)

Datafilling table RDTINV (Sheet 7 of 12)

Field	Subfield or refinement	Entry	Explanation and action
IRTU	TSTACCPA	TAP1, TAP2, or TBPP	Test access path. This field replaces the MTAUID and MTAPTID section of the original prompt PT_CONNECTION_INFO. The ERTU can connect to TAP 1, TAP 2 or TBPP. Note: The TAP 1 and TAP 2 are 4-wire interfaces. The TBPP is a 2-wire interface.
		refer to subfields	Integrated remote test unit. This selector identifies an IRTU on the RDT for NTT tests. This field contains subfields RTUNUM, TSTHDUSR, VERTID and TSTACCPA.
	RTUNUM	RTU1 or RTU2	The RTU number. This field determines which test head on the IRTU can be defined.
	TSTHDUSR	MAPIF, NTTIF or BOTH	Test head user. This field indicates which test system uses the test head. The test head can be MAP, NTT or BOTH. The test head entry determines if subfields ALTUSE and VERTID must be entered.
	ALTUSE	Y or N	Automatic line test use. Enter Y to use line test equipment for automatic line tests (ALT). For any other condition, enter N. The ALTUSE is required if TSTHDUSR is MAPIF or BOTH.
	VERTID	0-1023	Vertical identifier. This field replaces the VERTID section of the original prompt PT_CONNECTION_INFO. This field represents the vertical in the MTA matrix where the control path is tied. The VERTID is required if TSTHDUSR is NTTIF or BOTH.
	TSTACCPA	TAP1, or TAP2	Test access path. This field replaces the MTAUID and MTAPTID section of the original prompt PT_CONNECTION_INFO. The IRTU test head 1 connects to TAP 1. The IRTU test head 2 connects to TAP 2.

SCM-100 Software for AccessNode (continued)

Datafilling table RDTINV (Sheet 8 of 12)

Field	Subfield or refinement	Entry	Explanation and action
	SCSDUSED	Y or N	<p>Scan point/signal distributor point used. Enter Y if SD/SD points are used and provide the multiple that contains:</p> <ul style="list-style-type: none"> • INHSCGRP—range of 0-511 • INHSCPT—range of 0-6 • INHSDGRP—range of 0-511 • INHSDPT—range of 0-6 <p>For any other condition, enter N.</p>
NTTOPT		Y or N	<p>No test trunk signature option. This field indicates if the no test trunk (NTT) direct current (dc) voltage signature is enabled for a particular RDT. If the value is Y, the dc signature for POTS, coin and multi-party lines are provided. In any other occurrence, the signature is not provided for any line types.</p> <p>Note: When the NTTOPT field is entered as N or changed to N, the following message is output at the MAP terminal:</p> <p>NTT signature will not be provided during line maintenance.</p>

SCM-100 Software for AccessNode (continued)

Datafilling table RDTINV (Sheet 9 of 12)

Field	Subfield or refinement	Entry	Explanation and action
LINKTAB		numeric	<p>Link table. This table is a vector. This table has a maximum of 28 entries. These entries define the mapping of the C-side links of the RDT (logical link) to the P-side links (physical link) of the SMA2.</p> <p>Note: When you enter data in field C-side link table (LNKTAB), make sure the message links are not assigned to the same interface card. When the interface card supports two or more links, separate the message links by the number of links on the interface cards. If an attempt occurs to assign message links on the same interface card, table control issues a warning. To assign message links to the same interface card can cause an E1 power failure if the card fails. An E1 power failure is failure of all message links.</p> <p>Note: Changes to fields with multiple entries must occur in PROMPT mode only.</p>
		+ or \$	Continuation mark. Enter + to continue and \$ to end the vector.
PROT		Y or N	<p>Facility protection switching. Specifies if protection switching is supported. If yes, the protection link is the highest numbered link on the RDT in the LINKTAB field.</p> <p>Note: In BCS35, Y is not supported for the RFT.</p>
POTSPADG		STDLN	The POTS pad group. The correct values are UNBAL and STDLN. Enter STDLN as a value.
EOC		refer to subfields	<p>Embedded operations channel. Indicates if EOC is present, and if standard or LAPD parameters are in use. This field contains subfields EOCTYPE and ELAPDPAR.</p> <p>Note: The IDT and the channel must be offline for changes to occur.</p>

SCM-100 Software for AccessNode (continued)

Datafilling table RDTINV (Sheet 10 of 12)

Field	Subfield or refinement	Entry	Explanation and action
	EOCTYPE	S, O or N	<p>The EOC type. Indicates if EOC is present and if standard or optional LAPD parameters are in use. Enter</p> <ul style="list-style-type: none"> • S for standard LAPD parameters • O for optional LAPD parameters. The subfield ELAPDPAR appears. • N for no EOC present. <p>For the AccessNode, enter S or O.</p> <p>Note: Changes to the LAPD parameters of the EOC/CSC can occur when the IDT and the channel are manually busy or offline. When an RDT entry is S or O, the value of the UNIT in field RDTNAME must be 0.</p>
	ELAPDPAR	alphanumeric	<p>Enhanced LAPD parameters. Appears when O is entered in the EOCTYPE subfield. Specify the optional LAPD parameters. Enter five values, with a space between each value.</p> <ul style="list-style-type: none"> • N201 and a number from 1-256 • N200 and a number from 1-8 • K and a number from 1-128 • T203 and a number from 10-250 • T200 and a number from 100-250

SCM-100 Software for AccessNode (continued)

Datafilling table RDTINV (Sheet 11 of 12)

Field	Subfield or refinement	Entry	Explanation and action
SDPOINTS		alphanumeric	<p>Signal distribution point. Enter the SD point that corresponds to this RDT. If <i>which RDT SD points</i> are available for operation when the RDT enters an alarm, the range of values are:</p> <ul style="list-style-type: none"> • RDTSD1 • RDTSD2 • RDTSD3 • RDTSD4 • RDTSD5 • RDTSD6 • RDTSD7 • RDTSD8 <p>A maximum of 255 different groups of activated SD points are available to indicate the RDT raises an alarm. This field can be in use to group RDTs together. To perform this action, assign the same <i>which RDT</i> points to multiple RDTs.</p> <p>Note: Each SD point must first be entered in table ALMSD. The IDT must be offline to change any SD point. If field SDPOINTS is \$ (nil), the SD points that indicate alarm importance, RDTCRIT, RDTMAJOR and RDTMINOR do not activate. The nil indicates that no SD points for RDT alarms are entered.</p>
RDTDN		refer to subfields	<p>The RDT distinguished name. This name is a vector of one to five elements for the RDT_RDN. Each element represents a relative distinguished name (RDN) that comprises the distinguished name of the RDT. The entry of data in this field occurs only when an addition to an RDT tuple occurs. If an attempt to modify this field occurs, an error message is received.</p>

SCM-100 Software for AccessNode (continued)

Datafilling table RDTINV (Sheet 12 of 12)

Field	Subfield or refinement	Entry	Explanation and action
	RDN TYPE		<p>Relative distinguished name. Enter the RDN of the RDT. The range of values is as follows:</p> <ul style="list-style-type: none"> • NETWORK_ID • SYSTEM_ID • NETWORKELEMENT_ID • EQUIPMENT_ID <p>Note 1: This field cannot be edited for BCS35. The tuple must be deleted and added again. Make sure the values for this field match the values assigned to the S/DMS AccessNode. If these values do not correspond to the S/DMS AccessNode, lines are not provisioned.</p> <p>Note 2: For an RDT of type RFT, the network_id, system_id, and equipment_id values must be 1 to correspond to the values on the S/DMS AccessNode. If the values in this table are not 1, the following warning message appears: WARNING: The network_id, system_id and equipment_id are set to 1.</p>
	RDN VAL	0-32767	Relative distinguished name value. Enter the value for the RDN.

Datafill example for table RDTINV

Sample datafill for table RDTINV appears in the following example.

SCM-100 Software for AccessNode (continued)**MAP example for table RDTINV**

RDТNAME	ADNUM	IDТNAME	NENAME
	PRIMOPC		BACKOPC
		VARTYPE	CLAPDFLT
			MTSTACPT
NTTOPT			LINKTAB
PROT	POTSPADG	EOC	SDPOINTS
			RDTDN

CARY 03 0	10	SMA2 1 3	\$ AccessNode
	BRTPY205		\$
		RFT 1 7 1 96 Y	\$
	(TBP MAPIF 8 TBPP N)	(ERTU 9 TAP1 N)	\$
Y		(1 0) (2 3) (4 5)	\$
N	STDЛN	S	\$
	(NETWORK_ID 1) (SYSTEM_ID 1) (NETWORKELEMENT_ID 14)		
	(EQUIPMENT_ID 1) \$		

The following section contains possible error and warning messages for table RDTINV.

Error and warning messages for table RDTINV (Sheet 1 of 2)

Error/warning message	Explanation and action
Warning: Additional static data not updated for SMA2 <sma2_no> <unit_no>.	Failure of the dynamic update of static data.
Warning: Additional static data updates completed for SMA2.	Success of the dynamic update of static data.
Warning: SMA2 <sma2_no> is in overload. Static data update may fail.	An attempt occurs to move an IDT from one SMA2 to another SMA2. The SMA2 to which the IDT is to move, is in an overload condition. Static data can require a manual update after the IDT is moved.
Error: XPM message link <link_no> cannot be changed to a speech link.	An attempt occurs to change a current message link with a speech link.
Error: RDT <IDT_index> must be offline to change field RDTDN.	When an IDT is not offline, the system blocks an attempt to change field RDTDN of an RFT tuple.

SCM-100 Software for AccessNode (continued)

Error and warning messages for table RDTINV (Sheet 2 of 2)

Error/warning message	Explanation and action
Error: The specified RDTDN is already assigned to another RDT.	The IDT is offline. The system blocks an attempt to change field RDTDN of a RFT tuple to a value common between the RFT tuples.
Error: Invalid RDT DN - RDNs missing or out of order.	An attempt occurs to add or change the tuple that contains a minimum of one entry of network-id for an RFT tuple. The system blocks the request.
Error: More than two verticals are datafilled	Attempt to enter more than two verticals.
Error: Duplicate VERTID for MTSTACPT configuration.	Attempt to enter duplicate verticals.
Error: The verticals used are not sequential.	Attempt to enter non-sequential verticals.
Error: Duplicate TAP for MTSTACPT configuration.	Attempt to enter duplicate TAPs.
Error: MTSTACPT has duplicate entry of type TBP.	Attempt to datafill duplicate test units.
ERTU can only be used by NTT.	Attempt to enter an ERTU for a test system that is not correct uses.
Warning: Incorrect TEST ACCESS PATH for TBP. Change to TBPP.	Entry of the TAP that is not correct. The system accepts the data.
Key {RDT name} has been used in another table. Use different SITE, FRAME, and/or UNIT values.	Attempt to add a tuple in table RDTINV when the selected key is in another table.

SCM-100 Software for AccessNode (continued)

The following information contains warning messages that can appear when you enter IRTU information.

Warning messages for IRTU entries

Warning	Reason
Only one RTU is used by ALT	Refer to note.
ALTUSE field for RTU2 changed to N	The RTU1 has ALTUSE set to Y. An attempt occurs to add RTU2 with ALTUSE set to Y.
ALTUSE field for RTU1 changed to N	The RTU2 has ALTUSE set to Y. An attempt occurs to add RTU1 with ALTUSE set to Y.
Note: In response to the specified entry attempt, this warning message is combined with the other two IRTU warning messages.	

The limit on the entry was lessened. This entry limit means that a link cannot be deleted from field LINKTAB if ISDN lines are present on that RDT. A link *can* be deleted from field LINKTAB. You cannot delete ISDN lines if the lines use that specified link. The following error messages can occur.

Error messages for table RDTINV

Error message	Explanation and action
Error: There are active ISDN line tuples on this RDT. This RDT cannot be moved to another SMA2.	An attempt occurs that changes the C-side PM for the IDT. The attempt is invalid because ISDN lines are present on the RDT. All ISDN lines on the RDT must be deleted or set to HASU. All special connections on the RDT must be deleted before this change occurs.
Error: There are active ISDN line tuples on this RDT. The line configuration for this RDT cannot be changed.	An attempt occurs that changes or delete a current link in field LINKTAB. The attempt is invalid because ISDN lines are present on the RDT. All ISDN lines on the RDT must be deleted or set to HASU. All special connections on the RDT must be deleted before this change occurs.
Error: Static connections exist on the links to be deleted.	An attempt occurs that changes or delete a current link in field LINKTAB. The attempt is invalid because an ISDN line uses a channel on that link. The ISDN line or special connection that uses the channel must be changed or deleted before the deletion of the link.

SCM-100 Software for AccessNode (continued)

Datafilling table TMINV

The trunk module inventory (TMINV) table contains hardware and software information for each trunk module in an office. This table is important for the SMA2-RDT system because the table identifies the trunk modules or MTMs with test circuits. These circuits terminate test pairs that connect to RDT lines.

Datafill for SCM-100 Software for AccessNode for table TMINV appears in the following table. The fields that apply to SCM-100 Software for AccessNode appear in this table.

Datafilling table TMINV (Sheet 1 of 2)

Field	Subfield or refinement	Entry	Explanation and action
TMNM		refer to subfields	Trunk module number. This field contains subfields TMTYPE and TMNO.
	TMTYPE	TM8, MTM, or OAU	Trunk module type. Enter the trunk module type.
	TMNO	numeric	Trunk module number. Enter the trunk module number. Range for TM8 is 0-2047. The range for maintenance trunk module (MTM) is 0-255. For an office alarm unit (OAU), enter 0.
FRTYPE		TME	Frame type. Enter the frame type where the trunk module is located. Enter TME.
FRNO		0-511	Frame number. Enter the frame number of the TME frame.
SHPOS		numeric	Shelf position. Enter the base mount position of the trunk module. For TM8, range is 04, 18, 32, 51 or 65. For an MTM, enter 65. For an OAU, enter 51.
FLOOR		0-99	Floor. Enter the floor number where the trunk module is located.
ROW		alphabetic	Row. Enter the row number where the trunk module is located. The range is A-H, J-N, P-Z, AA-HH, JJ-NN, and PP-ZZ.
FRPOS		numeric	Frame position. Enter the bay position of the TME frame.

SCM-100 Software for AccessNode (continued)

Datafilling table TMINV (Sheet 2 of 2)

Field	Subfield or refinement	Entry	Explanation and action
LKDATA		refer to subfields	C-side link data. For switches with the JNET, this field contains subfields NMPAIR and NMPORT. For switches with the ENET, this field contains subfields ENSHELF, ENSLOT and ENLINK.
	NMPAIR	0-31	Network module pair number. Enter the network module number assigned to the trunk module.
	NMPORT	0-63	Network port number. Enter the network module port number assigned to the trunk module.
	ENSHELF	0-7	The ENET shelf number. Enter the shelf number where the PM is assigned.
	ENSLOT	10 to 16, 25 to 32, or 13 to 19	The ENET slot number. Enter the crosspoint slot number where the PM is assigned. Enter a value between 10 and 16 or 25 and 32. For a DMS SuperNode SE switching unit, enter a value between 13 and 19.
	ENLINK	0-15	The ENET link number. Enter the link on the crosspoint where the PM is assigned.
	ENDS30	0-15	The ENET DS30 Enter a value from 0 (zero) to 15 for fiber links. This field defaults to 0 (zero) if the link is a DS30. All entries must be contiguous from 0 (zero). Duplicate entries must not occur.
EQPEC		alphanumeric	Equipment product engineering code (PEC). Enter the PEC of the trunk module.
LOAD		alphanumeric	Load. Enter the issue name of the PM software.
EXECS		alphanumeric	Executive programs. Enter the set of executive programs required for the trunk module.

Datafill example for table TMINV

Sample datafill for table TMINV appears in the following example.

SCM-100 Software for AccessNode (continued)

MAP example for table TMINV

TMNM	FRTYPE	FRNO	SHPOS	FLOOR	ROW	FRPOS	LKDATA	EQPEC
LOAD								
EXECS			SCTMLOC					
TM8	0	TME	1	65	0	L	16	0 53 2X52AG
BTMKA02								
TM8EX			N					

Datafilling table TRKGRP

Table trunk group (TRKGRP) contains customer defined data associated with each trunk group in the switching unit. Each trunk group entry in table TRKGRP contains a different CLI for the trunk group. Each trunk group entry also contains a number of other fields the trunk group type (field GRPTYP) determines. The trunk group types that apply to the SMA2-RDT system are MAINT for maintenance trunks like MTU and TD for no test trunks like BASIC or MLT trunks. Table TRKGRP identifies test circuits associated with maintenance and test trunks.

SCM line monitor access

Operating company personnel at a remote test center can start tests on a subscriber line. The line can be in a call processing busy state. Subfield BARGE in table TRKGRP determines if access to the line can occur when in the bridged mode through a conference card. This action allows operating company personnel to verify the line is busy. This action also allows operating company personnel to use a no test trunk to not give a defective busy signal. When the subfield is Y, the line access can occur through a conference card. When the subfield is the default value N, line access cannot occur through a conference card.

Because of many configurations of table TRKGRP, an entry procedure is not provided for this table.

Datafill example for table TRKGRP

Sample datafill for table TRKGRP appears in the following example.

SCM-100 Software for AccessNode (continued)**MAP example for table TRKGRP**

GRPKEY	GRPINFO				
HSET					
	MAINT	0	NPDGP	NCRT	5X30AA
TERM101					
	MAINT	0	NPDGP	NCRT	5X30AA
JACK					
	MAINT	0	NPDGP	NCRT	1X54AA
LTU					
	MAINT	0	NPDGP	NCRT	2X11AA
MTU					
	MAINT	0	NPDGP	NCRT	2X90AD

Datafilling table TRKSGRP

Table trunk subgroup (TRKSGRP) lists additional information for each subgroup assigned to one of the trunk groups in table TRKGRP.

Specified input data must be available for at least one subgroup or a maximum of two subgroups for each trunk group in table TRKGRP. This condition does not apply to trunk groups defined as maintenance group types.

Note: Table TRKGRP entries automatically produce the trunk subgroup data for maintenance and test trunks. The data does not include subgroup one of trunk group with code TTU

Because of the many configurations of table TRKSGRP, an entry procedure is not provided for this table.

Datafill example for table TRKSGRP

Sample datafill for table TRKSGRP appears in the following example.

MAP example for table TRKSGRP

SGRPKEY	CARDCODE	SGRPVAR									
MTU 0	2X11BA										
STD OG	NP	WK	0	0	NO	NO	F	N	N	17	UNEQ
MONTALK 0	2X90AD										
STD OG	NP	WK	0	0	NO	NO	F	N	N	17	UNEQ
TTU 0	2X47AC										
STD OG	NP	WK	0	0	NO	NO	F	N	N	17	UNEQ

SCM-100 Software for AccessNode (continued)

Datfilling table TRKMEM

Table trunk member (TRKMEM) lists data associated with each trunk assigned to specified trunk groups and trunk subgroups in tables TRKGRP and TRKSGRP. Table TRKMEM identifies the circuits associated with test equipment and trunks entered in tables TRKGRP and TRKSGRP.

An entry procedure is not provided for this table.

Datfill example for table TRKMEM

Sample datfill for table TRKMEM appears in the following example.

MAP example for table TRKMEM

CLLI	EXTRKNM	SGRP	MEMVAR
MTU	0	0	MTM 0 22
MTU	1	0	MTM 2 2
HSET	0	0	TM8 0 4

Datfilling table SFWALARM

Table software alarm (SFWALARM) associates a software alarm with SD points that must be activated when software alarm activation occurs. Entries in this table cannot be added or deleted. Operating company personnel can change the data.

Datfill for SCM-100 Software for AccessNode for table SFWALARM appears in the following table. The fields that apply to SCM-100 Software for AccessNode appear in this table.

Datfilling table SFWALARM (Sheet 1 of 2)

Field	Subfield or refinement	Entry	Explanation and action
FUNCTION		alphanumeric	Function. Enter the system alarm function to a maximum of 16 characters. The system automatically adds the RDTWRN.
REPORT		Y or N	Report. Enter Y if an alarm report is logged. In any other occurrence enter N. For RDTWRN, this value must be N.
ALM		CR, MJ, MN, or NA	Alarm. Enter the type of alarm activated or not applicable (NA). For RDTWRN this value must be NA.

SCM-100 Software for AccessNode (continued)**Datafilling table SFWALARM (Sheet 2 of 2)**

Field	Subfield or refinement	Entry	Explanation and action
LOGIC		refer to subfields	Logic. This field consists of subfields SDFUNCT, ALMGRP, and ALMXFR.
	SDFUNCT	alphanumeric	Signal distributor function. Enter the signal distributor function(s) associated with a specified system alarm. For RDTWRN, this value must be RDTWARN.
	ALMGRP	Y or N	Alarm grouping. Enter Y if the alarm function started when the alarm grouping key activation occurred. For any other condition, enter N. For RDTWRN, this value must be N.
	ALMXFR	Y or N	Alarm transfer. Enter Y if the alarm function started when the alarm transfer key activation occurred. In any other condition, enter N. For RDTWRN, this value must be N.
	CONTMARK	+ or \$	Continuation mark. Enter a (+) sign to indicate the line continues, or a (\$) to indicate the end of the line.

Datafill example for table SFWALARM

Sample datafill for table SFWALARM appears in the following example.

MAP example for table SFWALARM

FUNCTION	REPORT	ALM	LOGIC
RDTCRT	N	CR	(RDTCRIT N N) \$
RDTMJ	N	MJ	(RDTMAJOR N N) \$
RDTMN	N	MN	(RDTMINOR N N) \$
RDTWRN	N	NA	(RDTWARN N N) \$

Datafilling table LINEATTR

Line attributes in table line attribute (LINEATTR) are assigned to regular lines in table LENLINES. Line attributes in LINEATTR are also assigned to Meridian stations and attendant consoles in MDC translation tables.

SCM-100 Software for AccessNode (continued)

Datafill for SCM-100 Software for AccessNode for table LINEATTR appears in the following table. The fields that apply to SCM-100 Software for AccessNode appear in this table.

Datafilling table LINEATTR (Sheet 1 of 4)

Field	Subfield or refinement	Entry	Explanation and action
LNATTIDX		0-1023	Line attribute index. Enter the index in the table.
LCC		alphanumeric	Line class code. Enter the line class code assigned to the line attribute index number. If a line class code is not available, enter NLCC.
CHGCLSS		alphanumeric	Charge class. Enter the charge class for switching units configured with Local Automatic Message Accounting (LAMA). For any other condition, enter NONE.
COST		HI, LO or NT	Class of service tone. Enter the class of service tone required.
SCRNCL		alphanumeric or NSCR	Class-of-service screening subtable name. Enter the four-character class of service assigned in the line attribute index. Enter NSCR if class screening is not required.
LTG		0-255	Line treatment group. Enter the line treatment group number assigned to the line attribute index.
STS		numeric	Serving translation scheme. Enter the three-digit serving numbering plan area (NPA) assigned to the line attribute index.
PRTNM		alphanumeric or NPRT	Standard pretranslator subtable name. Enter the four-character pretranslator subtable name assigned to the line attribute index. Enter NPRT if standard pretranslation is not required.
LCANAME		alphanumeric or NLCA	Local calling area screening subtable name. Enter the five-character local calling area screening subtable name assigned to the line attribute index. Enter NLCA if screening is not required.
ZEROMPOS		alphanumeric or NONE	Zero minus position. Enter the ten-character position in table POSITION where operator zero minus calls are routed. Enter NONE if operator zero minus calls are not present.

SCM-100 Software for AccessNode (continued)

Datafilling table LINEATTR (Sheet 2 of 4)

Field	Subfield or refinement	Entry	Explanation and action
TRAFSNO		0-127	Traffic separation number. Enter the network module number assigned to the trunk module.
CONTMARK		+	Continuation mark. Enter a plus sign (+) to indicate that additional information for the tuple is in the next record.
MRSA		alphanumeric or NIL	Message rate service area. Enter the eight-character message rate service area name in table MRSANAME field MRSA. Enter NIL if multi-unit message rate services are not required.
SFC		alphanumeric or NILSFC	International subscriber feature class. Enter a six-character international subscriber feature class name in table FEATCHG. Enter NILSFC if international classes are not required.
LATANM		alphanumeric	Local access and transport area name. Enter the eight-character local access and transport area name assigned to the line attribute index.
MDI		0	Metering data index. Enter the metering data index number assigned to the line attribute index. Enter 0 if international metering data is not required.
IXNAME		refer to subfields	International translation system start. Contains subfields XLASYS and XLANAME.
	XLASYS	AC, AM, CT, DT, FA, FT, OFC, NSC, PX, or NIL	International translation system. Enter the head table name where translation starts. Enter NIL if the switching unit does not have an international load.
	XLANAME	alphanumeric or NIL	International translation name. Enter the eight-character index that field XLASYS references. Enter a blank if the subfield entry XLASYS is NIL.
DGCL- NAME		alphanumeric or NIL	Digital analysis tables entry point. Enter an eight-character digital analysis name that appears in universal digit analysis tables DGHEAD and DGCODE. Enter NIL if the switching unit does not have an international load.

SCM-100 Software for AccessNode (continued)

Datafilling table LINEATTR (Sheet 3 of 4)

Field	Subfield or refinement	Entry	Explanation and action
FANIDIGS		two digit code: (N, 0, 1-9, B,C,D,E,F)	Flexible ANI information digit pairs. Enter the flexible automatic number identification information digit pair assigned to the line attribute index. Enter 00 if the switching unit does not have feature BR0713.
CONTMARK		+	Continuation mark. Enter a plus sign (+) to indicate that the next record contains additional information for the tuple.
RESINF		refer to subfields	Residential enhanced services information. Contains subfields RESINFO, CUSTGRP, SUBGRP, and NCOS.
	RESINFO	Y or N	Residential enhanced services information. Enter Y if the line attribute index must support residential (RES) lines. Enter N if the index does not support RES lines.
	CUSTGRP	alphanumeric	Customer group. Enter a 16-character group name assigned to the line attribute index in table CUSTENG.
	SUBGRP	0-7	Customer subgroup. Enter the subgroup in the customer group associated with the line attribute index.
	NCOS	0-255	Network class of service number. Enter the network class of service number in the customer group, associated with the line attribute index. The network class of service number is also in table NCOS.

SCM-100 Software for AccessNode (continued)**Datafilling table LINEATTR (Sheet 4 of 4)**

Field	Subfield or refinement	Entry	Explanation and action
OPTIONS		AMAGRPID, HOT, LDSV, or LCABILL	<p>Line attribute options. This field is a vector that contains four options.</p> <p>Enter AMAGRPID if a group identity for a subscription basis tariff is required.</p> <p>Enter HOT if identification of hotel lines to a traffic operator position system is required. Enter HOT if the outgoing trunk group is OP.</p> <p>Enter LDSV is long distance signal (LDS) or long distance alerting (LDA) is required. Enter subfield STATUS.</p> <p>Enter LCABILL if a carrier call that cannot be interexchanged is billable.</p>
	AMAGRPID	alphanumeric	Automatic message accounting group identifier. Enter the eight character group identifier in table AMAGRPID.
	STATUS	ACT or DEACT	Long Distance Signal Valid status. Enter ACT for long distance signal (LDS) or long distance alerting (LDA) activation for the line group. In any other occurrence, enter DEACT.
CONTMARK		\$	Continuation mark. Enter the dollar sign (\$) to indicate the end of the tuple.

Datafill example for table LINEATTR

Sample datafill for table LINEATTR appears in the following example.

MAP example for table LINEATTR

```

LNATTIDX LCC CHGCLSS COST SCRNL LG STS PRTNM LCNAM
ZEROMPOS TRAFSNO
MRSA SFC LATANM MDI IXNAME OGCLNAME FANIDIGS RESINF
OPTIONS
-----
0 1FR NONE NT NSCR 0 919 POTS LCA0 CTOP 20
NIL NILSFC NILLATA 0 NIL NIL 00 N $

```

SCM-100 Software for AccessNode (continued)

Datafilling table LNINV

Subscriber lines that connect to the RDT are entered in table line inventory (LNINV). This table defines the line equipment number (LEN) of a line and the hardware characteristics of the LEN.

The subfields that identify the line card are altered to allow a LEN to identify a RDT line card. In a LEN for a line concentrating module (LCM), the fields for the LEN are as follows:

- SITE
- FRAME
- UNIT
- SUBGROUP
- CIRCUIT

The LEN fields for RDT definition are as follows:

- SITE
- FRAME
- UNIT
- SHELF (This field defines the shelf number. The possible range is 1-22.)
- SLOT (This field defines the slot number. The possible range is 1-99. For the RFT, the range is 1-96. The maximum number of lines for each shelf is 96. Since the maximum number of lines is 2048, the last shelf is limited to 32. However, the RFT currently has a hardware limitation of 1344 lines.)

Note: The SITE, FRAME and UNIT numbers form a line module (LM) number. The SHELF and SLOT numbers are mapped to a terminal number.

How the maximum number of lines are controlled

The SHELF range maximum is 31 and the SLOT range maximum is 99. A maximum of 2976 lines is present.

As section "Datafilling table RDTINV" explains, field SHELFSLT limits the number of lines a RDT can have. This limit occurs when you must enter the maximum values for the shelf and slot numbers. Table RDTINV provides table control. The maximum number of lines for the RFT is 1344.

SCM-100 Software for AccessNode (continued)

Field CARDCODE is expanded to allow for the new types of line cards for the RDT. The following card codes are allowed:

- RDTCON—COIN
- RDTLSG—POTS (loop start/ground start)
- RDTEBS—MBS
- RDTISD—ISDN
- RDTILC—integrated line card

Note: A single SMA2 supports a maximum of 480 ISDN lines.

Note the following table interactions:

- The line assignments for coin lines occur in table LENLINES. The LNATTIDX field corresponds to the line class code, coin first (CCF), coin dial-tone first (CDF), or coin semi-post pay (CSP) in table LINEATTR.
- The POTS lines (RDTLSG) do not have corresponding tuples in KSET-type tables.
- For MBS, field VARTYPE in table RDTINV must be RFT.

Entries to table RDTINV must occur before entries to table LNINV. The DMS switch must know the RDT is present before the switch can know about lines on the RDT.

Note: The Omega SAA line card allows locally switched AccessNode RFT lines to be flow-through provisioned with the SERVORD. This action enables the operating company to bulk entry information for line cards in table LNINV. The default data is updated with the correct data for the type of service requested when services are supplied. Only fields CARDCODE, PADGROUP and GND are updated. This feature does not support Multi-party, Datapath, DID and IVD services.

SCM-100 Software for AccessNode (continued)

Reboot of the DMS-100



CAUTION

Risk of traffic degradation

If you enter table LNINV and a reboot of the DMS-100 switch occurs before the dump of office image to tape or disk, the office image for the reboot does not contain the entry for table LNINV. The dump is part of routine maintenance.

When this action occurs, restore the RDT ISDN line entries in table LNINV immediately after the reboot completes in one of two ways.

1. Input the entry information again for table LNINV at a terminal.
2. Apply the contents of the appropriate journal file to the DMS-100 office load.

Failure to restore the contents of table LNINV causes the following problems. The problems include D-channels that do not have proper release in the S/DMS AccessNode and traffic degradation. Another problem is the system generates LINE138 logs in the DMS switch.

The LNINV Provisioning that uses SERVORD for RDT Lines improves the service order process. This process allows the automatic addition or deletion of line entries in table LNINV for RDT lines.

The addition of a new service to a line can occur. A line entry is created based on user input, office parameter values and default values. The LNINV datafill was not present before a SERVORD request. The SERVORD user input determines values for fields LEN, CARDCODE, PADGRP, and GND.

A hard coded default value has the value for field BNV. The value for field MNO is from office parameter RDT_SO_AUTOCREATE_LNINV in table OFCENG.

Line entries in table LNINV can be present before a SERVORD transaction. The SERVORD alters the line entries to agree with the service request.

SCM-100 Software for AccessNode (continued)

The ILC Provisioning and RDTINV Table Control makes the following changes in table LNINV.

- The integrated line card (ILC) represents a *virtual* line card that emulates control, talk, and monitor path functionality. The control path transmits and receives data to the IRTU test head.
- The talk or monitor path is for talking or monitoring the line under test. To control which ILC represents which test head, and the function the ILC performs, each ILC must be different.

The RDTILC is a new value for field CARDCODE. The RDTILC represents the ILC used to interface the IRTU. New card types are added to field CARDINFO to allow the IRTU to access the AccessNode. The following is a list of new card types for field CARDINFO.

- ILC1C-ILC control path for test head 1
- ILC1T-ILC talk path for test head 1
- ILC2C-ILC control path for test head 2
- ILC2T-ILC talk path for test head 2

A limited number of test heads is available for each RDT and IDT. A maximum of four ILC entries can be present on the same RDT in table LNINV. A requirement is not available to have the IRTU installed at the AccessNode to supply the IRTU from the the DMS switch.

The line provisioning audit checks the call reference value. The audit also checks the head path information of the provisioned ILC every 24 h.

The ILCs provide origination and termination points for maintenance functions. Because ILCs represent a maintenance function without service capability, SERVORD only allows a directory number and one flat rate (1FR) service. This limit is for all IRTU line card creations. After the creation of the line object and the service is provisioned through SERVORD, the ILC state is set to idle.

Note: Because the ILC is a virtual concept, a line card is not associated with the IRTU line at the AccessNode. Each ILC must have an empty copper distribution shelf slot reserved. The OPC and RFT handles and performs all control and maintenance actions.

SCM-100 Software for AccessNode (continued)

The following limits apply to ILC Provisioning and RDTINV Table Control.

- The system supports flow through provisioning for RDTILC.
- Multi-host configuration supports ILC provisioning. The provisioning host is the only host with access to the ILC.
- The AccessNodes that run at AN08 or later supports ILC provisioning. The system blocks an attempt to enter an IRTU line card in table LNINV if the AccessNode runs at AN07 or earlier.



WARNING

Reserve an empty copper distribution shelf slot for each ILC.

For proper operation of ILCs, the slot where the ILC is provisioned must remain empty.

Entries for SCM-100 Software for AccessNode for table LNINV appear in the following table. Only fields that apply to SCM-100 Software for AccessNode appear.

Datafilling table LNINV (Sheet 1 of 3)

Field	Subfield or refinement	Entry	Explanation and action
LEN		refer to subfields	Line equipment number. This field contains the subfields SITE, RDTFRAME, RDTUNIT, RDTSHELF, and RDTSLLOT.
	SITE	alphanumeric	Site. Enter the location of the RDT. This entry is not optional, and default value assigned is not available.
	RDT FRAME	0-511	The RDT frame. Enter the RDT frame number. The number is not a frame. The number is a software entity that represents the group where the RDT belongs.
	RDT UNIT	0-9	The RDT unit. Enter the number that represents the RDT unit in the group.
	RDT SHELF	1-31	The RDT shelf. Enter the shelf number where the RDT resides.
	RDT SLOT	1-99	The RDT slot. Enter the slot number where the RDT resides.

SCM-100 Software for AccessNode (continued)

Datafilling table LNINV (Sheet 2 of 3)

Field	Subfield or refinement	Entry	Explanation and action
CARDCODE		RDTCON, RDTLSG, RDTEBS, RDTISD, and RDTILC	Card code. Enter the PEC of the line card or line card carrier. The following identifies the object class types for the cardcode values represented: <ul style="list-style-type: none"> • RDTCON-Coin • RDTLSG-Loop Start/Ground Start • RDTEBS-Meridian Business Set (MBS) • RDTISD-ISDN • RDTILC-IRTU line card
PADGRP		STDLN, UNBAL, PPHON, LRLM and NPDGP	Pad group. Enter the name of the pad group assigned to the line circuit in table PADATA. Pads can be applied on the lines at the SMA2. For cardcode RDTILC, STDLN is the recommended response for field PADGRP.
STATUS		HASU, WORKING, UNEQUIP, CUTOFF, and RESERVED	Status. Enter the line inventory availability status. For cardcode RDTILC, for field STATUS, the recommended response is HASU.
GND		Y or N	Ground. Where line is ground start, enter Y. For any other condition, enter N for loop start. For cardcode RDTILC, for field GND, the recommended response is N.
BNV		L or NL	Balanced network value. Enter L when line circuit configuration is for a loaded network. In any other occurrence, enter NL for a network that is not loaded. For cardcode RDTILC, for field BNV, the recommended response is NL.

SCM-100 Software for AccessNode (continued)

Datafilling table LNINV (Sheet 3 of 3)

Field	Subfield or refinement	Entry	Explanation and action
MNO		Y or N	Manual override. Enter Y when on-hook balance network test is prevented from an update in field BNV. For any other condition, enter N to allow off-hook balance network test to update field BNV. For cardcode RDTILC, field MNO, the recommended response is N.
CARDINFO		RCUPOTS, RCUEPOTS, SSLCC, ILC1C, ILC1T, ILC2C, ILC2T, or NIL	Card information. The default value is NIL. For SMA2, enter NIL. When CARDCODE is RDTILC, enter ILC1C, ILC1T, ILC2C, or ILC2T.

Datafill example for table LNINV

Sample datafill for table LNINV appears in the following example.

MAP example for table LNINV

LEN	CARDCODE	PADGRP	STATUS	GND	BNV	MNO
CARDINFO						

CARY 01 0 04 10	RDTILC	STDLN	HASU	N	NL	N
ILC1C						

Other provisioning functions

The RDTPROV command can be performed at the CI level of the MAP display. This command allows operating company personnel to start reprovisioning without going to the table level of the MAP display. The reprovisioning occurs for all failed lines on a specified RDT or all failed lines on all RDTs from the SMA2.

After operating company personnel enter the RDTPROV command, operating company personnel use the command string REPROV LEN <len> to start the reprovisioning request. The request is for a failed line on a specified RDT. The <len> is the line equipment number. For example: **>PROV CARY 01 0 07 96**

SCM-100 Software for AccessNode (continued)

If the request is successful, the system response is the identification of the LEN and indication that the request is complete. An example is:

```
LEN: CARY 01 0 07 96 RDT line provisioning request completed
```

Additional RDTPROV parameters are:

- the REPROV IDT <ext_idtno>. The ext_idtno is the external IDT number that has a value from 0 to 255. This command string can reprovision all failed lines on a specified RDT.
- the REPROV ALL can reprovision all failed lines on all the RDTs.

Datafilling table RDRTL

Table remote digital terminal line termination (RDRTL) contains information on the next operation the line object provisioning process performs. The next operation occurs on a line that connects to the RDT. The LEN of the line card identifies the line. This table correlates the LEN of the line card to the state of the message flow. The message flow is on the line-related objects between the DMS SuperNode switch and the RDT.

A tuple is added to this table when you enter a new line for the RDT in table LNINV. Delete a tuple for this table when you delete a line that connects to the RDT. Table RDRTL is a *read-only* table.

The fields automatically entered for table RDRTL appear in the following table. The following table is for information only.

Datafilling table RDRTL (Sheet 1 of 10)

Field	Subfield or refinement	Entry	Explanation and action
LEN		refer to subfields	Line equipment number. This field defines the location of the equipment that connects to a specified telephone line. For ISDN lines, field LEN contains subfield LTID. For lines that are not ISDN, field LEN contains subfields SITE, FRAME, UNIT DRAWER. Field LEN can also contain LSG, SHELF, SLOT, and CIRCUIT.
ACCESS		refer to below	Line provisioning process operation. This field identifies the operation the line provisioning process performs for an RDT line.
Note: The previous values that end with 1 are for delete and create operations.			

SCM-100 Software for AccessNode (continued)

Datafilling table RDTLT (Sheet 2 of 10)

Field	Subfield or refinement	Entry	Explanation and action
		ACCESS_NIL	Operations are not required.
		I_ACCESS_DONE	Line objects provisioning for ISDN line complete.
		I_CHA_IPTIS_CONF	Wait for response to message: CHANGE PRIMARY STATE OF ISDN PATH TERMINATION (PT) TO IN SERVICE
		I_CHA_IPTIS_REQ	Send message: CHANGE PRIMARY STATE OF ISDN PT OBJECT TO IN SERVICE
		I_CHA_IPTOOS_CONF	Wait for response to message: CHANGE PRIMARY STATE OF ISDN PT TO OUT OF SERVICE
		I_CHA_IPTOOS_CNOF1	Wait for response to message: CHANGE PRIMARY STATE OF ISDN PT TO OUT OF SERVICE
		I_CHA_IPTOOS_REQ	Send message: CHANGE PRIMARY STATE OF ISDN PT OBJECT TO OUT OF SERVICE
		I_CHA_IPTOOS_REQ1	Send message: CHANGE PRIMARY STATE OF ISDN PT OBJECT TO OUT OF SERVICE
		I_CHA_LTIS_CONF	Wait for response to message: CHANGE PRIMARY STATE OF ISDN LINE TERMINATION (LT) TO IN SERVICE
		I_CHA_LTIS_REQ	Send message: CHANGE PRIMARY STATE OF ISDN LT OBJECT TO IN SERVICE

Note: The previous values that end with 1 are for delete and create operations.

SCM-100 Software for AccessNode (continued)

Datafilling table RDTLT (Sheet 3 of 10)

Field	Subfield or refinement	Entry	Explanation and action
		I_CHA_LTO- OS_CONF	Wait for response to message: CHANGE PRIMARY STATE OF ISDN LT TO OUT OF SERVICE
		I_CHA_LTO- OS_CONF1	Wait for response to message: CHANGE PRIMARY STATE OF ISDN LT TO OUT OF SERVICE
		I_CHA_LTO- OS_REQ	Send message: CHANGE PRIMARY STATE OF ISDN LT OBJECT TO OUT OF SERVICE
		I_CHA_LTO- OS_REQ1	Send message: CHANGE PRIMARY STATE OF ISDN LT OBJECT TO OUT OF SERVICE
		I_CRE_ A1DCT_ CONF	Wait for response to message: CREATE FIRST DS-0 CHANNEL TERMINATION (CT) OBJECT
		I_CRE_ A1DCT_REQ	Send message: CREATE FIRST DS-0 CT OBJECT
		I_CRE_ A2DCT_ CONF	Wait for response to message: CREATE SECOND DS-0 CT OBJECT
		I_CRE_ A2DCT_REQ	Send message: CREATE SECOND DS-0 CT OBJECT
		I_CRE_ AQDCT_ CONF	Wait for response to message: CREATE QDS-0 CT OBJECT
		I_CRE_ AQDCT_REQ	Send message: CREATE QDS-0 CT OBJECT
		I_CRE_ ICT_ CONF	Wait for response to message: CREATE ISDN CT OBJECT
Note: The previous values that end with 1 are for delete and create operations.			

SCM-100 Software for AccessNode (continued)

Datafilling table RDTLT (Sheet 4 of 10)

Field	Subfield or refinement	Entry	Explanation and action
		I_CRE_ICT_REQ	Send message: CREATE ISDN CHANNEL TERMINATION (CT) OBJECT
		I_CRE_IPT_CONF	Wait for response to message: CREATE ISDN PT OBJECT
		I_CRE_IPT_REQ	Send message: CREATE ISDN PATH TERMINATION (PT) OBJECT
		I_CRE_LT_CONF	Wait for response to message: CREATE ISDN LT OBJECT
		I_CRE_LT_REQ	Send message: CREATE ISDN LINE TERMINATION (LT) OBJECT
		I_DEL_IPT_CONF	Wait for response to message: DELETE PT AND ALL SUBTENDING OBJECTS
		I_DEL_IPT_CONF1	Wait for response to message: DELETE PT AND ALL SUBTENDING OBJECTS
		I_DEL_IPT_REQ	Send message: DELETE ISDN PT AND ALL SUBTENDING OBJECTS
		I_DEL_IPT_REQ1	Send message: DELETE ISDN PT AND ALL SUBTENDING OBJECTS
		I_DEL_IPT_CONF1	Wait for response to message: DELETE PT AND ALL SUBTENDING OBJECTS

Note: The previous values that end with 1 are for delete and create operations.

SCM-100 Software for AccessNode (continued)

Datafilling table RDTLT (Sheet 5 of 10)

Field	Subfield or refinement	Entry	Explanation and action
		I_DEL_IPT_REQ	Send message: DELETE ISDN PT AND ALL SUBTENDING OBJECTS
		I_DEL_IPT_REQ1	Send message: DELETE ISDN PT AND ALL SUBTENDING OBJECTS
		I_DEL_LT_CONF	Wait for response to message: DELETE LT AND ALL SUBTENDING OBJECTS
		I_DEL_LT_CONF1	Wait for response to message: DELETE LT AND ALL SUBTENDING OBJECTS
		I_DEL_LT_REQ	Send message: DELETE ISDN LT AND ALL SUBTENDING OBJECTS
		I_DEL_LT_REQ1	Send message: DELETE ISDN LT AND ALL SUBTENDING OBJECTS
		P_ACCESS_DONE	Line objects provisioning for analog or electronic business set (EBS) line done.
		P_CHA_LTIS_CONF	Wait for response to message: CHANGE PRIMARY STATE OF LINE TO IN SERVICE
		P_CHA_LTIS_REQ	Send message: CHANGE PRIMARY STATE OF LINE TO IN SERVICE
		P_CHA_LTOOS_CONF	Wait for response to message: CHANGE PRIMARY STATE OF LINE TO OUT OF SERVICE

Note: The previous values that end with 1 are for delete and create operations.

SCM-100 Software for AccessNode (continued)

Datafilling table RDTLT (Sheet 6 of 10)

Field	Subfield or refinement	Entry	Explanation and action
		P_CHA_LTOOS_CONF1	Wait for response to message: CHANGE PRIMARY STATE OF LINE TO OUT OF SERVICE
		P_CHA_LTOOS_REQ	Send message: CHANGE PRIMARY STATE OF LINE TO OUT OF SERVICE
		P_CHA_LTOOS_REQ1	Send message: CHANGE PRIMARY STATE OF LINE TO OUT OF SERVICE
		P_CRE_LT_CONF	Wait for response to message: CREATE ANALOG OR EBS LT OBJECT
		P_CRE_LT_REQ	Send message: CREATE ANALOG OR EBS LINE TERMINATION (LT) OBJECT
		P_DEL_LT_CONF	Wait for response to message: DELETE LT AND ALL SUBTENDING OBJECTS
		P_DEL_LT_CONF1	Wait for response to message: DELETE LT AND ALL SUBTENDING OBJECTS
		P_DEL_LT_REQ	Send message: DELETE LT AND ALL SUBTENDING OBJECTS
		P_DEL_LT_REQ1	Send message: DELETE LT AND ALL SUBTENDING OBJECTS
		P_MOD_LT_CONF	Wait for response to message: MODIFY LT OBJECTS

Note: The previous values that end with 1 are for delete and create operations.

SCM-100 Software for AccessNode (continued)

Datafilling table RDTLT (Sheet 7 of 10)

Field	Subfield or refinement	Entry	Explanation and action
TRANSP		P_MOD_LT_REQ	Send message: MODIFY ANALOG OR EBS LINE TERMINATION OBJECT
		refer to note	Rdt line processor transport states. This field identifies the next operation the line provisioning process performs for creation of the objects for the transport part of the cross-connect.
		TRANSP_NIL	Operations are not required.
		TRANSP_DONE	All operations are complete.
		I_ADD_TDPT_CONF	Wait for response to message: UPDATE DS-0 CT OBJECT
		I_ADD_TDPT_REQ	Send message: UPDATE TRANSPORT SIDE DS-0 CT OBJECT TO INCLUDE DS0 PT OBJECT
		I_CHA_TDPTIS_CONF	Wait for response to message: CHANGE PRIMARY STATE OF DS-0 PT TO OUT OF SERVICE
		I_CHA_TDPTIS_REQ	Send message: CHANGE PRIMARY STATE OF DS-0 PT OBJECT TO IN SERVICE
		I_CHA_XCOOS_CONF1	Current use is not present.
		I_CHA_XCOOS_REQ1	Current use is not present.
	I_CRE_TDPT_CONF	Wait for response to message: CREATE DS-0 PT OBJECT	
Note: The previous values that end with 1 are for delete and create operations.			

SCM-100 Software for AccessNode (continued)

Datafilling table RDTLT (Sheet 8 of 10)

Field	Subfield or refinement	Entry	Explanation and action
		I_CRE_TDPT_REQ	Send message: CREATE TRANSPORT SIDE DS-0 PATH TERMINATION (PT) OBJECT
		I_CRE_TQDCT_CONF	Wait for response to message: CREATE QDS-0 CT OBJECT
		I_CRE_TQDCT_REQ	Send message: CREATE TRANSPORT SIDE QDS-0 CT OBJECT
		I_CRE_XC_CONF	Wait for response to message: CROSS CONNECTION OBJECT
		I_CRE_XC_REQ	Send message: CREATE TRANSPORT SIDE CROSS CONNECTION OBJECT
		I_DEL_TDPT_CONF	Wait for response to message: DELETE DS-0 PT OBJECT
		I_DEL_TDPT_REQ	Send message: DELETE DS-0 PT OBJECT
		I_DEL_TQDCT_CONF	Wait for response to message: DELETE QDS-0 CT OBJECT
		I_DEL_TQDCT_CONF1	Wait for response to message: DELETE QDS-0 CT OBJECT
		I_DEL_TQDCT_REQ	Send message: DELETE QDS-0 CT OBJECT
		I_DEL_TQDCT_REQ1	Send message: DELETE QDS-0 CT OBJECT
Note: The previous values that end with 1 are for delete and create operations.			

SCM-100 Software for AccessNode (continued)

Datafilling table RDTLT (Sheet 9 of 10)

Field	Subfield or refinement	Entry	Explanation and action
		I_DEL_XC_ CONF	Wait for response to message: DELETE CROSS CONNECTION OBJECT
		I_DEL_XC_ CONF1	Wait for response to message: DELETE CROSS CONNECTION OBJECT
		I_DEL_XC_ REQ	Send message: DELETE CROSS CONNECTION OBJECT
		I_DEL_XC_ REQ1	Send message: DELETE CROSS CONNECTION OBJECT
CONTMARK		+ or \$	Enter + if additional information for this tuple is in the next record. For any other condition, enter \$ to indicate the end of the tuple.
REQUESTR		refer to below	Request process. This field allows table control to display the process that uses RDTLT resources. The information below allows the table control software to determine from where the request was initiated.
		REQUESTOR_ NIL	A requestor is not present.
		REQUESTOR_ RDTLP	Request starts from RDTLP process.
		REQUESTOR_ DUMPREST	Request starts from dump and restore process.
		REQUESTOR_ JFILE	Request starts from journal file update process.
CRV		0-4095	Call reference value range. This field represents the call reference value range.
LOPDONE		Y or N	Line object provisioning done. This field is Y (yes) when all line object provisioning is complete.
Note: The previous values that end with 1 are for delete and create operations.			

SCM-100 Software for AccessNode (continued)

Datafilling table RDTLT (Sheet 10 of 10)

Field	Subfield or refinement	Entry	Explanation and action
DELALL		Y or N	Delete all tuples. This field is Y when the table control software accepts a request to delete all entries in table RDTLT.
LTIS		Y or N	Line termination in-service. This field is Y when the line termination object (LTO) is in service.
INSMOD		Y or N	In service modifier. This field is Y to identify if a request to update the in service attributes of the LTO is sent.

Note: The previous values that end with 1 are for delete and create operations.

Datafill example for table RDTLT

Sample datafill for table RDTLT appears in the following example.

MAP example for table RDTLT

```

RDTLTKEY      ACCESS          TRANSP      NAILUP1
  NAILUP2    REQUESTR  CRV  LOPDONE  DELALL  LTIS  INSMOD
LTCLASS  QDS0INFO      XCINFO

-----
CARY 03 0 2 1  P_ACCESS_DONE  TRANSP_NIL  NAILUP_NIL
  NAILUP_NIL  REQUESTOR_NIL  201  Y      N      Y      N
ANALOG_LT    0 0 0 0      0 0 0
    
```

Datafilling table LENLINES

Table LENLINES contains the following data:

- site name of remote location
- party of assigned DN
- ringing code of an assigned DN

Note: Addition of an RDT-related tuple can occur to this table if the CARDCODE field in table LNINV is RDTLSG, RDTCON, or RDTMPY.

SCM-100 Software for AccessNode (continued)**Datafilling table SCGRP**

Table scan group (SCGRP) lists the PEC and location of scan groups that provide scan points for line features. Each scan card provides 14 scan points that divides to two scan groups. Each scan group has a TM circuit number.

Note: Assign lines at a remote location to scan points that belong to scan groups at the remote location.

Table SDGRP is required datafill for the set up of mechanized loop tests of RDT subscriber lines. The definition of SD groups in mechanized loop tests are in this table. The definition of SD points that drive the applique circuit in mechanized loop tests are in table LTDS.

Entries for SCM-100 Software for AccessNode for table SCGRP appear in the following table. Only fields that apply to SCM-100 Software for AccessNode appear.

Datafilling table SCGRP

Field	Subfield or refinement	Entry	Explanation and action
SCGRPNO		0-511	Scan group. Enter the scan group number.
TMTYPE		MTM, RMM, or RSM	Trunk module type. Enter the type of trunk module where the miscellaneous scan card is mounted.
TMNO		0-255	Trunk module number. Enter the number assigned to the MTM, RMM, or RSM where the miscellaneous scan card is mounted.
TMCKTNO		0-23	Trunk module circuit number. Enter the trunk module circuit number on the MTM, RMM or RSM, the scan group is assigned.
CARDCODE		0X10AA	Enter the PEC of the scan card.

Datafill example for table SCGRP

Sample datafill for table SCGRP appears in the following example.

SCM-100 Software for AccessNode (continued)

MAP example for table SCGRP

SCGRPNO	TMTYPE	TMNO	TMCKTNO	CARDCODE
0	MTM	1	14	0X10AA
1	MTM	1	15	0X10AA
2	RSM	1	12	0X10AA
3	RSM	1	13	0X10AA

Datafilling table SDGRP

Table signal distributor group (SDGRP) lists the PEC and location of SD groups that provide SD points for line features. Each SD card provides 14 SD points in two SD groups. Each SD group has an assigned TM circuit number.

Note: Assign lines at a remote location to SD points that belong to SD groups at the remote location.

Table SDGRP is a required entry to arrange mechanized loop tests of RDT subscriber lines. The definition of SD groups in mechanized loop tests are in this table. The definition of SD points that drive the applique circuit in mechanized loop tests are in table LTDS.

Datafill for SCM-100 Software for AccessNode for table SDGRP appears in the following table. The fields that apply to SCM-100 Software for AccessNode appear in this table.

Datafilling table SDGRP (Sheet 1 of 2)

Field	Subfield or refinement	Entry	Explanation and action
SDGRPNO		0-511	Signal distributor group. Enter the signal distributor group number.
TMTYPE		MTM, RMM or RSM	Trunk module type. Enter the type of trunk module where the signal distributor card is mounted.
TMNO		0-2047	Trunk module number. Enter the number assigned to the MTM, RMM, or RSM where the signal distributor card is mounted.

SCM-100 Software for AccessNode (continued)**Datafilling table SDGRP (Sheet 2 of 2)**

Field	Subfield or refinement	Entry	Explanation and action
TMCKTNO		0-29	Trunk module circuit number. Enter the trunk module circuit number on the MTM, RMM, or RSM, where the signal distributor group is assigned.
CARDCODE		2X57AA	Cardcode. Enter the PEC of the signal distributor card.

Datafill example for table SDGRP

Sample datafill for table SDGRP appears in the following example.

MAP display example for table SDGRP

SDGRPNO	TMTYPE	TMNO	TMCKTNO	CARDCODE
0	MTM	0	14	2X57AA
1	MTM	0	15	2X57AA
2	RSM	0	14	2X57AA
3	RSM	0	15	2X57AA

How to enter data into table LTSDS

Table line test desk signal distribution (LTSDS) identifies the SD points that drive the applique circuit during mechanized loop tests. Use of the applique circuit with an NT2X90AD test trunk reports line card diagnostic results to mechanized loop test equipment. A mechanized loop tester or local test desk is an example of this equipment.

The applique circuit uses four SD points. These points belong to one or more SD groups in table SDGRP. This table must be entered before table LTSDS. The SD points do not have to be from the same SD group.

Enter table LTSDS after table TRKMEM. Table TRKMEM is a key identification in table LTSDS. Valid trunk group members belong to trunk group type test desk (TD), version MLT or TSTDK.

SCM-100 Software for AccessNode (continued)

Datafill for SCM-100 Software for AccessNode for table LTSDSD appear in the following table. Only fields that apply to SCM-100 Software for AccessNode appear.

Datafilling table LTSDSD

Field	Subfield or refinement	Entry	Explanation and action
TDMEM		refer to subfields	Trunk member. This field contains subfields CLLI and MEMNAME.
	CLLI	alphanumeric	Common language location identifier. Enter the code assigned in table CLLI.
	MEMNAME	0-9999	Trunk member name. Enter the trunk member that uses the SD circuit card.
TSDSDGRP1		0-511	Test desk signal distribution group 1. Enter the SD group where the first SD point belongs.
TSDSDPT1		0-6	Test desk signal distribution point 1. Enter the number of the first SD point that drives relay DS-1 in the applique circuit.
TSDSDGRP2		0-511	Test desk signal distribution group 2. Enter the SD group where the second SD point belongs.
TSDSDPT2		0-6	Test desk signal distribution point 2. Enter the number of the second SD point that drives the relay DS2 in the applique circuit.
TSDSDGRP3		0-511	Test desk signal distribution group 3. Enter the SD group where the third SD point belongs.
TSDSDPT3		0-6	Test desk signal distribution point 3. Enter the number of the third SD point that drives relay DS3 in the applique circuit.
TSDSDGRP4		0-511	Test desk signal distribution group 4. Enter the SD group where the fourth SD point belongs.
TSDSDPT4		0-6	Test desk signal distribution point 4. Enter the number of the fourth SD point that drives relay DS4 in the applique circuit.

Datafill example for table LTSDSD

Sample datafill for table LTSDSD appears in the following example.

SCM-100 Software for AccessNode (continued)**MAP example for table LTDS**

TDMEM	TSDGRP1	TSDPT1	TSDGRP2	TSDPT2	TSDGRP3	TSDPT3	TSDGRP4	TSDPT4
MLTRK	1	6	5	6	6	7	0	
	7	1						

Datafilling table MTAMDRVE

Table metallic test access minibar driver (MTAMDRVE) is a matrix of vertical and horizontal crosspoints. These crosspoints that connect specified verticals to horizontal in the network. These crosspoints are like a minibar circuit.

The metallic test access (MTA) connects test equipment. The test equipment connects to a horizontal crosspoint. The crosspoint connects to a circuit that requires tests through a test bypass pair. The bypass pair connects to a vertical crosspoint.

The interconnection of a number of smaller minibar circuits can construct an MTA network of the required size. The smaller minibar circuits are building block components and appear in the figure below.

The NT3X09AA driver allows metallic test access to remote line concentrating devices. Access to the devices includes the RDT. The NT3X09AA is a four vertical-by-eight horizontal circuit. The NT3X09BA is an eight vertical-by-eight horizontal circuit.

SCM-100 Software for AccessNode (continued)

MTA matrix

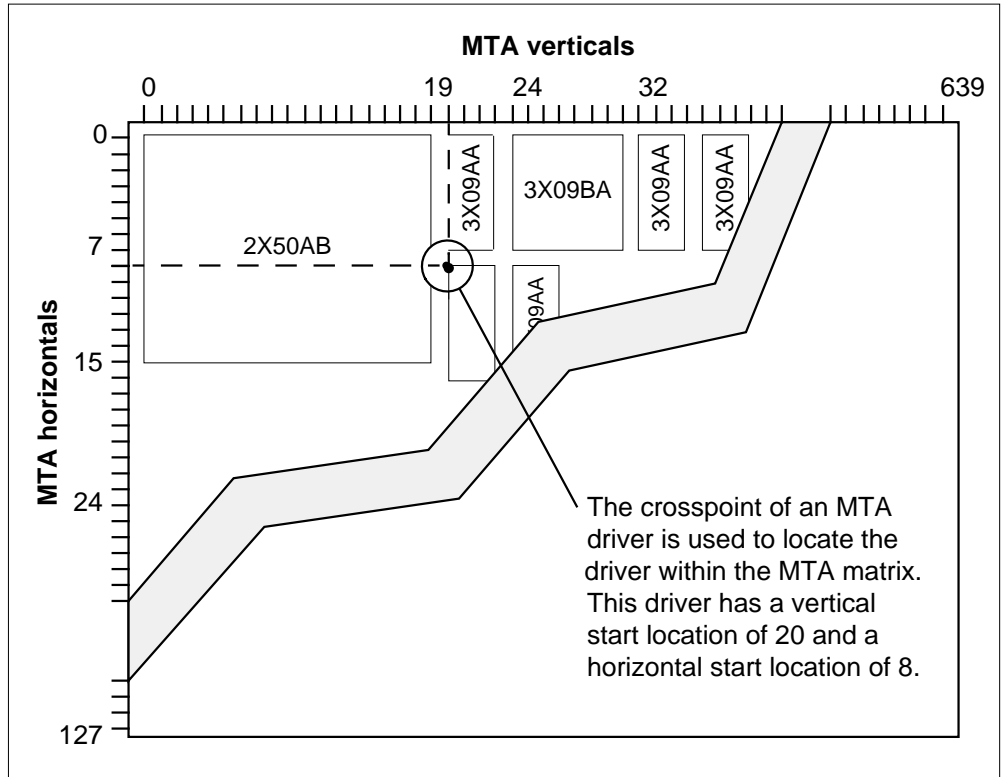
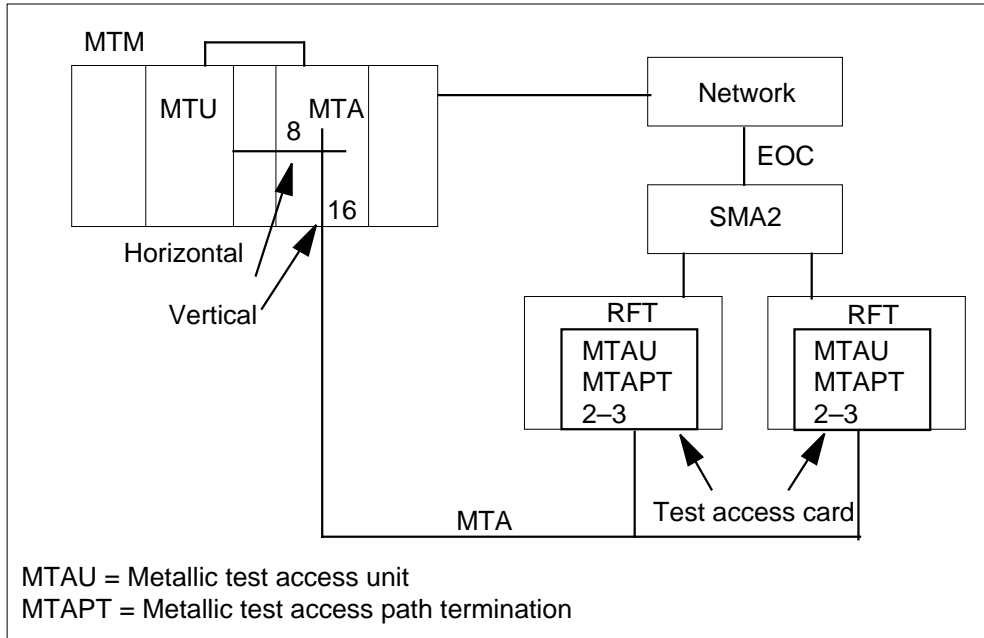


Table MTAMDRVE specifies the location and the type of MTA. The NT3X09 driver has relays on the card and does not require an associated minibar switch. Each MTA has a 0, 0 crosspoint in the matrix.

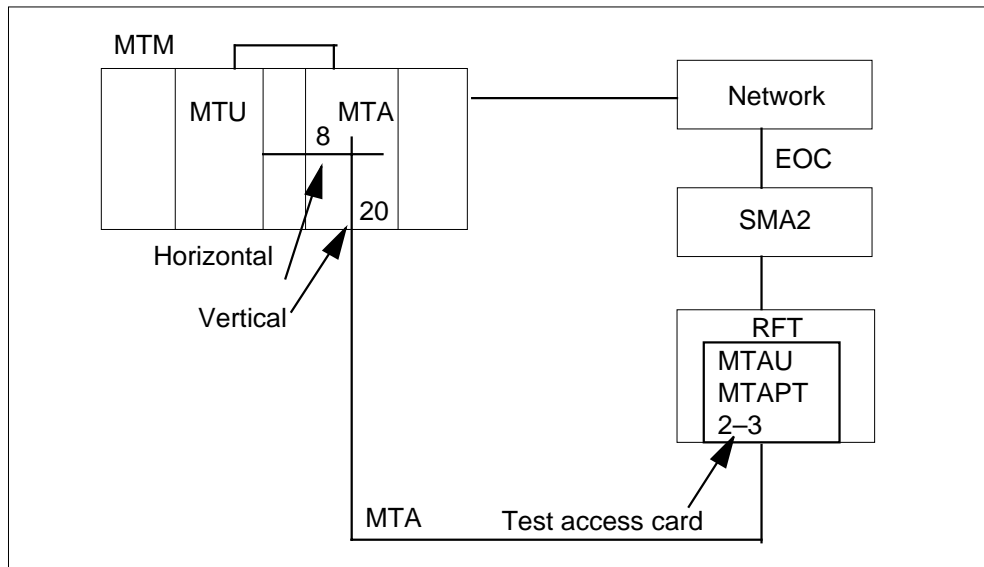
The MTA datafill examples through to the end of this chapter appear in the following figures.

SCM-100 Software for AccessNode (continued)

Multiple RDTs on one test bypass pair



Metallic test bypass for only one RFT



SCM-100 Software for AccessNode (continued)

Datafill for SCM-100 Software for AccessNode for table MTAMDRVE appear in the following table. Only fields that apply to SCM-100 Software for AccessNode appear.

Datafilling table MTAMDRVE

Field	Subfield or refinement	Entry	Explanation and action
MTAMEM		0-255	Metallic test access minibar driver member. Enter the MTA driver member number. This number is the key to this table.
VERT		0-639	MTAM driver vertical start location. Enter the vertical start location for the MTAM driver.
HORIZ		0-127	MTAM driver horizontal start location. Enter the horizontal start location for the MTAM driver.
TMTYPE		MTM	Trunk module type. Enter the type of trunk module where the MTA is mounted.
TMNO		0-255	Trunk module number. Enter the number of the maintenance trunk module.
TMCKTNO		0-28 (even numbers)	Trunk module circuit number. Enter the circuit number of the MTM where the MTA is assigned.
MTACARD		2X50AB, 3X09AA, or 3x09BA	MTAM driver card. Enter the card code for the MTA card.

Datafill example for table MTAMDRVE

Sample datafill for table MTAMDRVE appear in the following example.

MAP example for table MTAMDRVE

MTAMEM	VERT	HORIZ	TMTYPE	TMNO	TMCKTNO	MTACARD
1	20	8	MTM	1	10	3X09BA

Datafilling table MTAVERT

Table metallic test access vertical connection (MTAVERT) identifies the vertical connection to the MTA matrix. Table MTAVERT modifications allow one or two verticals to be entered for one or more RDTs.

SCM-100 Software for AccessNode (continued)

The two types of connections allowed are single and multiple. The SMA2 system uses the multiple connection. A maximum of 32 RDTs can share a metallic test pair.

Datafill for SCM-100 Software for AccessNode for table MTAMDRVE appears in the following table. The fields that apply to SCM-100 Software for AccessNode appear in this table.

Datafilling table MTAVERT

Field	Subfield or refinement	Entry	Explanation and action
VERT		0-1023	Vertical. Enter the MTA vertical connection number.
VERTCONN		S or M	Vertical connection. Enter S or M to indicate single or multiple connections. For multiple connections, a maximum of 32 RDTs can share a metallic test pair.
	SELECTOR	O or L	Selector. When selector O is in use, the entry in VERTCONN is M. The subfields SITE, FRAME and UNIT must be entered after the selector. This selector is a vector of a maximum of 32 entries. When L is in use, the entry in VERTCONN is S. The subfields SITE, FRAME, and UNIT must be entered.
	SITE	alphanumeric	Site. Enter the name selected for the remote location.
	FRAME	0-511	Frame. Enter the frame number.
	UNIT	0-9	Unit number. Enter the unit number.
	CONTMARK	+ or \$	Continuation mark. Enter a plus sign (+) when additional data appears on the next record. For any other condition, enter a dollar sign (\$) after last record.

Datafill example for table MTAVERT

Sample datafill for table MTAVERT appears in the following example.

SCM-100 Software for AccessNode (continued)

MAP example for table MTAVERT

VERT	VERTCONN
16	M (O RDT1 00 0)
17	S (O RDT1 02 0)
18	S (O RDT1 03 0)
19	S (L RDT1 04 0)

Datafilling table MTAHORIZ

Table metallic test access horizontal connection (MTAHORIZ) lists the assignment of horizontal agents to a horizontal and horizontal group of metallic test access minibars. Horizontal agents are metallic test units (MTU), operator verification, metallic jacks (MJACK), incoming test access trunks, extended metallic test access and short circuits.

Different horizontal agents can use the same horizontal. These agents must be associated with different metallic test access minibars or horizontal groups. A maximum of 160 different horizontal agents is allowed for a given horizontal.

A maximum of 32 MTAMs can be grouped to connect to a single horizontal agent. Use of a horizontal agent can occur only one time.

When an LTU is assigned to the host switching unit, the horizontal where the LTU is assigned is multiplied to all minibar switches. These switches are assigned to the host switching unit.

When an LTU is assigned to a remote location, the horizontal where the LTU is assigned is multiplied to all minibar switches. These switches are assigned to the remote location.

The minibar switch can be at the host switching unit. When this condition occurs, an assignment limit is not present for the assignment of incoming test and operator verification trunks. One horizontal is required for each incoming test access trunk and operator verification trunk.

Where the MTA configuration is small or medium, the horizontals where the incoming test access. Operator verification trunks are assigned and multiplied to all minibar switches at the host switching unit.

The minibar switch is remote from the host switching unit. When this condition occurs, all horizontals are available for the assignment of incoming test access trunks. Other horizontal assignments include operator verification trunks and the extension of metallic test access feature.

SCM-100 Software for AccessNode (continued)

Each incoming test access trunk and each operator verification trunk requires one horizontal. Each vertical on the host minibar switch assigned to a horizontal on the minibar switch at the remote or host location requires one horizontal.

The maximum number of metallic jacks in each DMS switch is 256.

Refer to tables TRKGRP, TRKSGRP, and TRKMEM, in that order, for assignment of LTUs, incoming test access, and operator verification trunks. Locate trunk group, trunk subgroup and trunk member tables in these tables.

An MTU must be entered in table TRKMEM before the addition of an MTU can occur in table MTAHORIZ. If you delete MTU from table TRKMEM, the system marks the associated tuple in table MTAHORIZ as deleted. The system automatically restores the associated tuple in table MTAHORIZ if the addition of the MTU occurs again in table TRKMEM.

The memory for this table is dynamically allocated a maximum of 2000 tuples.

The MTU replaces the LTU. When you enter an LTU, a warning can appear at the MAP terminal with an explanation. The correct entry is MTU.

Datafill for SCM-100 Software for AccessNode for table MTAHORIZ appear in the following table. Only fields that apply to SCM-100 Software for AccessNode appear.

Datafilling table MTAHORIZ (Sheet 1 of 3)

Field	Subfield or refinement	Entry	Explanation and action
HORIZ		0-127	MTA horizontal. Enter the MTA horizontal where the test equipment (horizontal agent) connects.
HORIZGRP		0-159	MTA horizontal group. Enter the horizontal group number that identifies the horizontal and the horizontal agent as a different tuple. The horizontal group allows assignment of different test equipment on the same MTA horizontal.
HORIZAGT		refer to subfields	Horizontal agent. This field contains many subfields that depend on the value of SELECTOR.

SCM-100 Software for AccessNode (continued)

Datafilling table MTAHORIZ (Sheet 2 of 3)

Field	Subfield or refinement	Entry	Explanation and action
	SELECTOR	S, L, T, B, E, MJ, J, and LA	<p>Selector.</p> <p>Enter S for a timed short circuit.</p> <p>Enter L for LTU or MTU assignment and complete subfields CLLI, EXTRKNM, and ALTUSE.</p> <p>Enter T for incoming test access or operator verification trunk assignment. Complete subfields CLLI and EXTRKNM.</p> <p>Enter B for a board-to-board dedicated horizontal. Complete subfield BBTNR.</p> <p>Enter E to multiply a horizontal of a minibar switch from a host or remote to the vertical of a host minibar switch. Complete subfield EMTAVERT.</p> <p>Enter MJ for metallic connection to the tip and ring of the subscriber line. Complete subfields CLLI and MJACKNUM.</p> <p>Selectors J and LA are for licensee use only.</p> <p>Enter NT1 for the test network termination 1 (NT1). Complete subfield NT1NUM.</p>
	CLLI	LTU, MTU, MJACK, or alphanumeric	<p>Common language location identifier. Enter LTU for line test unit. Enter MTU for metallic test unit.</p> <p>For operator verification or an incoming test access trunk, enter the alphanumeric code that represents this trunk group in table CLLI.</p> <p>Enter MJACK for metallic jack.</p>
	EXTRKNM	0-9999	<p>External trunk number. Enter the external trunk number assigned in table TRKMEM to the line test unit, metallic test unit, operator verification trunk or the incoming test access trunk.</p>
	ALTUSE	Y or N	<p>Automatic line test use. Enter Y to use line test equipment for automatic line tests (ALT). For any other condition, enter N.</p>
	BBTNR	0-7	<p>Board-to-board testing number. Enter the number of the board-to-board set where this horizontal is associated.</p>

SCM-100 Software for AccessNode (continued)**Datafilling table MTAHORIZ (Sheet 3 of 3)**

Field	Subfield or refinement	Entry	Explanation and action
MTAGRP	EMTAVERT	0-639	Extended metallic test access column. Enter the associated vertical on the MTA in the host of the horizontal connection location.
	MJACKNUM	1-256	Metallic jack number. Where the entry in subfield CLLI is MJACK, enter the metallic jack number.
	NT1NUM	0-255	Network termination 1 number. Enter the number of the test NT1 in the DMS test system with which this horizontal connection is associated.
		numeric	The MTA group. This field contains a list of MTA drivers that multiply to the test equipment. This field is a vector of a maximum of 32 multiples of subfields MTAMEM and HORIZ.
	MTAMEM	0-255	The MTA minibar driver member. Enter the MTAM driver member number where the horizontal connects.
	HORIZ	0	This field is read-only. This field provides information on the horizontal where the MTA drivers connect. Enter 0 to satisfy table control.
	CONTMARK	+ or \$	Continuation mark. Enter a plus sign (+) when additional data appears on the next record. For any other condition, enter a dollar sign (\$) after the last record.

Datafill example for table MTAHORIZ

Sample datafill for table MTAVERT appears in the following example.

MAP example for table MTAHORIZ

HORIZ	HORIZGRP	HORIZAGT	MTAGRP
8	0 L	MTU 0 Y	(0 0) (2 0) \$

Datafilling table AMAOPTS

Table AMA options (AMAOPTS) controls the activation and schedule of the recording options for automatic message accounting (AMA). Table AMAOPTS contains one tuple for each option. This table contains the default values for each option.

SCM-100 Software for AccessNode (continued)

Datafill for the SCM-100 Software for AccessNode for table AMAOPTS appear in the following table. Only fields that apply to SCM-100 Software for AccessNode appear.

Datafilling table AMAOPTS

Field	Subfield or refinement	Entry	Explanation and action
AMAOPT		DSCWID_ CONF_AUDIT	The DSCWID conference audit. Key field in table AMAOPTS.
	AMAOPT	alphanumeric	The AMA option. Enter the appropriate option for your application.
SCHEDULE			Schedule. This field contains many subfields. Subfield AMASEL appears.
	AMASEL	PERIODIC, OFF, or DEFAULT	The AMA option selected. Selects audit OFF or PERIODIC. Default is OFF. Note: To enable the DSCWID conference audit, AMASEL must be set to PERIODIC, or DEFAULT where the DEFAULT is PERIODIC.

Changes made to a tuple in table AMAOPTS that use the table editor appear in the following example:

SCM-100 Software for AccessNode (continued)

```

>POS DSCWID_CONF_AUDIT
DSCWID_CONF_AUDIT
>CHA
TUPLE TO BE CHANGED:
DSCWID_CONF_AUDIT OFF
ENTER Y TO CONFIRM, N TO REJECT, OR E TO EDIT
>E
AMASEL: OFF
>PERIODIC
ONDATE:
>940915
ONTIME:
>0000
SCHEDULE:
>24 HRS
TUPLE TO BE CHANGED:
DSCWID_CONF_AUDIT PERIODIC 940915 0000 24 HRS
ENTER Y TO CONFIRM, N TO REJECT, OR E TO EDIT
Y

```

Datafill example for table AMAOPTS

Sample datafill for table AMAOPTS appears in the following example.

MAP example for table AMAOPTS

OPTION	SCHEDULE
DSCWID_CONF_AUDIT	OFF

Datafilling table TEXTPHRS

Virtual screen list editing (VSLE) and other display features use table text phrases (TEXTPHRS). Table TEXTPHRS contains instructional and prompting text strings that comprise separate logical display phrases.

SCM-100 Software for AccessNode (continued)

Datafill for SCM-100 Software for AccessNode for table TEXTPHRS appears in the following table. The fields that apply to SCM-100 Software for AccessNode appear in this table.

Datafilling table TEXTPHRS

Field	Subfield or refinement	Entry	Explanation and action
PHRSNAME		alphanumeric	Phrase name. Enter the 2 to 8 character name of the phrase in table TEXTLOG.
PHRASE		alphanumeric	Phrase. Enter the test string that appears as instructional or prompting messages. This field is a vector of a maximum of 40 characters. Display capabilities are 20 characters at a time.
HLMODE		refer to subfields	High light mode. This field contains subfields POSITION and MODE. A maximum of four highlight modes can be defined. Each mode contains a position and a mode.
	POSITION	0 to 40	POSITION. Specifies the character position of the change in highlight mode. The characters this subfield specifies are highlighted according to the selected mode. The characters continue until the end of the display or until the next mode position is specified.
	MODE	Normal, Reverse, Grey, or Bold	MODE. Enter the value range. The default mode is NORMAL.

Datafill example for table TEXTPHRS

Sample datafill for table TEXTPHRS appears in the following example.

SCM-100 Software for AccessNode (continued)**MAP example for table TEXTPHRS**

PHRSNAME	PHRASE HLMODE
CLCOUNT	GENERIC_CALLOG_ITEM_COUNT
CLNEWCT	GENERIC_CALLOG_NEW_COUNT
CLOLDCT	GENERIC_CALLOG_OLD_COUNT
CLNAMEIT	GENERIC_CALLOG_NAME_ITEM
CLDNIT	GENERIC_CALLOG_DN_ITEM
CLPRIM	GENERIC_CALLOG_PRIMARY
CLCURNUM	GENERIC_CALLOG_ITEM_NUMBER
CLTITLE	Call_Logging_Service
CLOLD	_Old
CLNEW	_New_
CLDIAL	Dialing...'
CLREMOVE	Removed...'
CLERASED	Erased_All_Calls
CLDNLD1	Processing_
CLDNLD2	_Calls
CLEMPY	No_Calls...Hang_up
CLNODIAL	Cannot_Return_Call
CLCLOSE	Session_Complete

Datafilling table TEXTLOG

The VSLE and other display features use table logical display text (TEXTLOG). Table TEXTLOG contains the names of the phrases that comprise a logical display phrase.

Datafill for SCM-100 Software for AccessNode for table TEXTLOG appears in the following table. The fields that apply to SCM-100 Software for AccessNode appear in this table.

Datafilling table TEXTLOG (Sheet 1 of 2)

Field	Subfield or refinement	Entry	Explanation and action
LPHRSKEY		refer to subfields	Logical phrase key. Contains subfields application name, language and display number.
	APPLNAME	VSLE, DSCWID, or CALLOG	Application name. Enter the name of the feature application this tuple uses.

SCM-100 Software for AccessNode (continued)

Datafilling table TEXTLOG (Sheet 2 of 2)

Field	Subfield or refinement	Entry	Explanation and action
	LANGUAGE	NILANG, LANG1, or LANG2	Language. Enter the language for the display.
	DISPNUM	0 to 127	Display number. Enter the numeric index the feature application identifies as the display data in the tuple.
DISPTYPE		S, T, or C	Display type. Enter S for standard display, T for transient display or C for cursor control.
LRCI		CENTER, RIGHT, LEFT, or INDENT	Left right center indent. This indent is the display justification indicator field. Enter the desired mode of justification.
PHRSLIST		alphanumeric	Phrase list. Enter the list of phrase names as defined in table TEXTPHRS.
DEFNLIST		refer to subfields	Definer list. Contains subfields SOFTKEY, MODE, and SKT.
	SOFTKEY	1 to 33	Softkey definer number from the list of softkey definer numbers defined in field DEFNUM of table SOFTKEY.
	MODE	N, H	Mode. Value is N for normal or H for highlight.
	SKT	SRV or CPE	Softkey table. Indicates which softkey table is in the CPE.

Datafill example for table TEXTLOG

Sample datafill for table TEXTLOG appears in the following example.

MAP example for table TEXTLOG

```

LPHRSKEY DISPTYPE LRCI
                                PHRSLIST
                                DEFNLIST
-----
CALLOG LANG1 1 S LEFT
                                ( CLTITLE)$
                                ( 1 N SRV )$
    
```

SCM-100 Software for AccessNode (continued)**Datafilling table SOFTKEY**

Table SOFTKEY specifies softkey information for application services. The index in table SOFTKEY is an application service identifier and a softkey definer number. Table TEXTLOG references entries in table SOFTKEY.

Datafill for SCM-100 Software for AccessNode for table SOFTKEY appears in the following table. The fields that apply to SCM-100 Software for AccessNode appear in this table.

Datafilling table SOFTKEY

Field	Subfield or refinement	Entry	Explanation and action
SERVID		alphanumeric	Service identifier. Enter a character string that corresponds to a specified application. This field is a vector of 0-8 characters.
DEFNUM		2 to 33	Defining numbers. Enter a numeric value to identify the softkey definer for use with the specified application.
LLABEL		alphanumeric	Label. Enter the label on the customer premise equipment (CPE) set display. This label appears on the line above the softkeys. This field is a vector of 1-18 characters.
SLABEL		alphanumeric	Subset of label. Enter a string of characters that correspond to the characters in the long label that are not optional. The characters in this field are a subset of the LLABEL field. This field is a vector of 1-7 characters.
RETURN		alphanumeric	Return. Enter the character string returned to the DMS switch when you press the associated softkey. This field is a vector of a maximum of 14, with a range of 0-255.

Datafill example for table SOFTKEY

Sample datafill for table SOFTKEY appears in the following example.

SCM-100 Software for AccessNode (continued)

MAP example for table SOFTKEY

SERVID	DEFNUM	LLABEL	SLABEL	RETURN
CALLOG	2	UNDO	UNDO	(50) \$
CALLOG	3	UNDO	UNDO	(51 133) \$
CALLOG	4	TOP	TOP	\$
CALLOG	5	BOTTOM	BOT	\$
CALLOG	6	ERASE	ERAS	(52) \$
CALLOG	7	REMOVE	REM	(55 133) \$
CALLOG	8	DIAL	DIAL	(56 133) \$
CALLOG	9	NAME	NAME	(57 133) \$
CALLOG	10	NUMBER	NUM	(48 133) \$
CALLOG	11	NEXT	NEXT	(53) \$
CALLOG	12	BACK	BACK	(54) \$

Datafilling table DSCWDTYP

Table deluxe spontaneous call waiting types (DSCWDTYP) defines different DSCWID types. Table DSCWDTYP has a maximum of 20 tuples. The initial entry for this table is six tuples. The keys PROPRITY, ADSITIME, ADSICID, NODATA, NOCIDCW, and COMPLETE are the keys used for the entries. The PROPRITY key indicates Proprietary DSCWID. Operating company personnel cannot change or delete the PROPRITY tuple. The only table control function permitted on the other five tuples is the CHANGE command. Operating company personnel can define a maximum of 14 additional DSCWID types. When you add a new tuple, changes to the NAME field cannot occur. Operating company personnel can remove or delete a tuple from table DSCWDTYP when field COUNT is zero. Operating company personnel cannot change Field COUNT.

Datafill for SCM-100 Software for AccessNode for table DSCWDTYP appear in the following table. Only fields that apply to the DSCWID feature of SCM-100 Software for AccessNode appear. For a description of the other fields, refer to the data schema section of the *Translation Guide*.

Note: Table DSCWDTYP must be entered before you define the DSCWID type in table RESOFC.

SCM-100 Software for AccessNode (continued)

Datafilling table DSCWDTYP (Sheet 1 of 2)

Field	Subfield or refinement	Entry	Explanation and action
NAME		PROPRITY ADSITIME, ADSID, or NODATA, NOCIDCW, or COMPLETE	The DSCWDTYP table key. Enter the name given to each DSCWID type. This field has a maximum of eight characters. Note: The PROPRITY tuple is fixed to accommodate the proprietary DSCWID feature.
ALERT		SASONLY or SASCAS	Type of alerting tone. Enter the type of alert supplied.
CID		NOCID, ALLCID, or TIMECID	Caller ID delivery. Enter the type of CID transferred during the DSCWID session. Options are no data (NOCID), all data of CID type (ALLCID), delivery time, and date only (TIMECID).
NONADSI		Y or N	Non ASDI. This field permits DSCWID features to be assigned to non-ADSI sets. When N, non-ADSI sets can only signal ANSWER and RETURN softkey options. When Y, non-ADSI sets can signal all softkey options in the KEYOPTS field.
<p>Note 1: Operating company personnel cannot change or delete the PROPRITY tuple and can only change (not delete) the other 5 initial tuples.</p> <p>Note 2: The ALERT type must be SASCAS to display ADSI complaint features. The SASONLY alert type provides a shorter call wait function and uses less SMA resources for non-ADSI type sets.</p> <p>Note 3: If CID type is ALLCID, a CID feature must be assigned in table RESOFC.</p>			

SCM-100 Software for AccessNode (continued)

Datafilling table DSCWDTYP (Sheet 2 of 2)

Field	Subfield or refinement	Entry	Explanation and action
COUNT		0 to 99,999	Line count. This field contains the number of lines assigned this DSCWID type. Note: Operating company personnel cannot change this field. Operating company personnel cannot delete tuples from table DSCWDTYP unless the count is 0. The default value is 0.
KEYOPTS		ALL, ANSWER, RETRN, FWD, BUSY, HOLD, DROP, CONF, DROPFRST, and DROPLAST	Softkey options. This field contains the softkey options available on this DSCWID type. The default value is ALL. Note: Changes to fields with multiple entries must be made in the PROMPT mode only.
<p>Note 1: Operating company personnel cannot change or delete the PROPRITY tuple and can only change (not delete) the other 5 initial tuples.</p> <p>Note 2: The ALERT type must be SASCAS to display ADSI complaint features. The SASONLY alert type provides a shorter call wait function and uses less SMA resources for non-ADSI type sets.</p> <p>Note 3: If CID type is ALLCID, a CID feature must be assigned in table RESOFC.</p>			

Datafill example for table DSCWDTYP.

Sample datafill for table DSCWDTYP appears in the following example.

SCM-100 Software for AccessNode (continued)**MAP example for table DSCWDTYP**

NAME	ALERT	CID	NON	ADSI	COUNT	KEY	OPTS
PROPRITY	SASCAS	ALLCID		N	0		
(ANSWER)	(FWD)	(BUSY)	(HOLD)	(DROP)	(RETRN)	\$	
ADSITIME	SASCAS	TIMECID		N	0		
					(ALL)	\$	
ADSIDCID	SASCAS	ALLCID		N	0		
					(ALL)	\$	
NODATA	SASONLY	NOCID		Y	0		
					(ALL)	\$	
NOCIDCW	SASCAS	TIMECID		Y	0		
					(ALL)	\$	
COMPLETE	SASCAS	ALLCID		Y	0		
					(ALL)	\$	

Tools for verifying translations

The SCM-100 Software for AccessNode does not use tools for verifying translations.

SERVORD

Use the SERVORD, not the table editor, to add and delete tuples to and from table LTMAP, IBNLINES, IBNFEAT, LENLINES, LENFEAT, RESOFC, and RESFEAT. If you use the table editor to enter data in these tables, the assignment to the line of features that are not compatible can occur.

Table LTMAP contains information on ISG numbers, the PM type, the services provided and the allocation of service channels.

Table IBNLINES contains the line assignments for 500 and 2500 sets assigned to MDC, RES and multiple appearance directory number (MADN) station numbers.

Note: Attendant consoles entries occur through the table editor in table IBNLINES.

SCM-100 Software for AccessNode (continued)

Table IBNFEAT lists the line features assigned MDC lines in table IBNLINES. Use one entry for each feature assigned to a MDC line.

Note: Final line data is loaded in the switch with the table editor. Additions, deletions and changes to table IBNFEAT must occur through SERVORD.



CAUTION

Loss of service

Use SERVORD, not the table editor, to add and delete tuples to and from tables KSETINV, KSETLINE, KSETFEAT, LENLINES, IBNFEAT RESOFC, and RESFEAT. The table editor is for entering the test line and final line data from tape.

Table KSETINV contains inventory data for each card slot assigned to a business set or data unit. The line card slot must be entered in table LNINV before entry in table KSETINV.

Table KSETLINE contains data on directory number (DN) appearances on business sets and data units. One entry is required for each DN-related key on the set. The key for table KSETLINE is a line equipment number (LEN). The LEN is for business sets and data units.

Table KSETFEAT lists line features for business sets, data units and ISDN terminals in table KSETLINE. The key for table KSETFEAT is the LEN for business sets and data units.

Table LENLINES contains the following data:

- site name assigned to remote location
- party of the location of the DN
- ringing code assigned to a DN

Table LENFEAT list the features for a specified line in table LENLINES.

Table RESOFC contains data on CLASS features. The CLASS features are public network features. These features are targeted for residential customers. For each CLASS feature assigned, table RESOFC controls if the feature is enabled or disabled for the whole office. If disabled, a CLASS line cannot use that feature, when the feature is assigned. Table RESOFC also controls the attributes associated with each feature.

SCM-100 Software for AccessNode (continued)

Table RESFEAT contains the assignment of CLASS features for residential lines.

Table CDCLENS lists the LENs for a customer group that has the Customer Service Change feature. The LENs for this table can only be assigned in tables INBLINES or KSETINV.

SERVORD limits

The following SERVORD limits apply to SCM-100 Software for AccessNode:

- Line assignments for stations with 500 and 2500 sets are assigned in table LENLINES. These line assignments are not assigned to an MDC or RES customer group. Line assignments for business sets and data units are made in table KSETLINE.
- You can add an RDT-related tuple in table IBNFEAT only if you enter field CARDCODE in table LNINV as RDTLSG.
- To add any LEN to table IBNLINES or KSETINV through table control or service order is automatically added to table CDCLENS. The LEN must have the customer data changed (CDC) option. Delete the CDC option from a line to delete the entry from table CDCLENS.
- Different formats are present for table KSETINV and the format that applies is the format for business sets. The formats for business sets use a LEN.
- You can add an RDT-related tuple in tables KSETINV and KSETFEAT. You must enter field CARDCODE in table LNINV as RDTEBS.
- You can add an RDT-related tuple in table LENLINES only if field CARDCODE in table LNINV is RDTLSG or RDTCON.
- You can add an RDT-related tuple in table LENFEAT only if field CARDCODE in table LNINV is RDTLS, RDTLSG or RDTCON.

SERVORD prompts

The SERVORD prompts that add a 1FR line to the SCM-100 Software for AccessNode appear in the following table. Refer to the *Servord Reference Manual* for a complete description of SERVORD command and prompts.

SERVORD prompts for SCM-100 Software for AccessNode (Sheet 1 of 2)

Prompt	Valid input	Explanation
DN	Numeric	Directory number to be added.
LCC	Alphanumeric	Line class code.
LATA- NAME	Alphanumeric	Local access and transport area name.

SCM-100 Software for AccessNode (continued)

SERVORD prompts for SCM-100 Software for AccessNode (Sheet 2 of 2)

Prompt	Valid input	Explanation
LTG	Numeric	Line treatment group.
LEN or LTID	Numeric	Line equipment number or logical terminal id.
OPTION	Alphanumeric or \$	Option(s) assigned to the line.

SERVORD example for adding SCM-100 Software for AccessNode

The addition of a 1FR line to the SCM-100 Software for AccessNode with the NEW command appears in the following SERVORD example.

SERVORD example for SCM-100 Software for AccessNode in prompt mode

```

>NEW
and pressing the Enter key.
SONUMBER:  NOW 94 5 11 AM
>
and pressing the Enter key.
DN:
> 2790011
and pressing the Enter key.
LCC:
> 1FR
and pressing the Enter key.
LATANAME:
> NILLATA
and pressing the Enter key.
LTG
>0
and pressing the Enter key.
LEN or LTID:
>RFT1 0 0 2 0
and pressing the Enter key.
OPTION
> $
and pressing the Enter key.

```

SERVORD example for SCM-100 Software for AccessNode in no-prompt mode

```

> NEW 2790011 1FR NILLATA 0 RFT1 0 0 2 0 $

```

SCM-100 Software for AccessNode (continued)**Interpreting a LEN**

The fields of the LEN that define the RFT are as follows:

- SITE
- FRAME
- UNIT
- SHELF (This field defines the shelf number. The possible range is 1-22.)
- SLOT (This field defines the slot number. The possible range is 1-99. For the RFT, the range is 1-96. The maximum number of lines for each shelf is 96. Since the maximum number of lines is 2048, the last shelf is limited to 32. However, the RFT currently has a hardware limitation of 1344 lines.)

SERVORD examples for how to add DSCWID options to a subscriber line

The addition of DSCWID feature to the SMA with the ADO command appears in the following SERVORD examples. Assume in table RESOFC the:

- default DSCWID type (DTYPE) is set to ADSITIME.
- DSCWID conference (AMA) status is set to NONE.
- DSCWID default treatment (DEFTRMT) is set to FWD.

The addition of DSCWID to 621-5000 with the default characteristics of DSCWID type ADSITIME appears in the following example.

MAP of SERVORD Add Option (ADO) command using defaults

```

SERVORD
SO:
>ADO
SONUMBER:  NOW YY MM DD
>$
DN_OR_LEN
>6215000
OPTION:
>DSCWID
SUBOPT:
>$
OPTION:
>$
COMMAND AS ENTERED:
ADO NOW YY MM DD 6215000 (DSCWID $) $
ENTER Y TO CONFORM, N TO REJECT, OR E TO EDIT
Y

```

SCM-100 Software for AccessNode (end)

The addition of DSCWID to 621-5000 with the characteristics of DSCWID type ADSICID appears in the following example. The AMA recording status is CONF and the default treatment is ANNC.

MAP of SERVORD Add Option (ADO) command with overrides

```
SERVORD
SO:
ADO
SQNUMBER:  NOW YY MM DD
>$
DN_OR_LEN
>6215000
OPTION:
>DSCWID
SUBOPT:
>DTYPE
DTYPE:
>ADSICID
SUBOPT:
>DEFTRMT
DEFTRMT
>ANNC
SUBOPT:
>$
OPTION:
>$
COMMAND AS ENTERED:
ADO NOW YY MM DD 6215000 (DSCWID (DTYPE ADSICID)
(DAMA NONE) (DEFTRMT ANNC) $) $
ENTER Y TO CONFORM, N TO REJECT, OR E TO EDIT
Y
```

SMA ICB Links

Order codes

Functional group order code: SMA00012

Release applicability

SMA ICB Links was introduced in NA008/XPM81.

Requirements

SMA ICB Links does not have requirements.

Description

The SMA ICB Links feature allows the expanded subscriber carrier module access (ESMA) to provision integrated channel banks (ICB). The ESMA is also referred to as the SMA2. The SMA2 requires this feature to support D4 channel banks and implement line services. This feature uses foreign exchange subscriber (FXS) protocol to support these channel banks.

In this SMA2 to channel bank configuration, a DS-1 can have a direct connection from the customer premises channel bank to an SMA2. This connection allows this connectivity without the additional equipment costs of line concentrating modules (LCM), enhanced ISDN line concentrating modules (LCME), and central office channel banks.

Channel banks that connect to an SMA2 have a logical representation at the DMS SuperNode switch. This representation is an ICB. Each ICB can include up to four channel banks. Therefore, the logical representation, the ICB, can control four channel banks and the DS-1 links. If four channel banks are configured as a single ICB, then the logical representation controls 96 lines.

Operation

A channel bank is a communications device that multiplexes voice signals. A channel bank that connects to an SMA2 has a logical representation at the SuperNode switch. This representation is the ICB. The ICB is another integrated digital terminal (IDT). The ICB is a virtual component that assigns the resources of the DMS SuperNode switch that supports the channel bank. The ICB includes the DS-1s and the line appearances.

The ICB configuration provides operating companies with lower equipment costs. Integrated channel banks remove the requirement for a channel bank and terminating line card in the central office. Operating companies that use ICBs can use DS-1 bandwidth that is not in use on current SMA2s for increased customer access.

SMA ICB Links (continued)

Channel banks in the ICB configurations have the following characteristics.

- support FXS signaling for plain old telephone service (POTS) loop and ground start lines
- separate operations, administration and maintenance (OA&M) from the SuperNode switch
- separate line and loop tests from the SuperNode switch
- do not provide protection switching for the DS-1 link that serves the ICB
- provide a maximum of 96 lines with no concentration on the peripheral side (P-side) of the SMA2
- conform to the AT&T D4 channel bank specification

Padding on ICB lines

When provisioning new channel banks, consider pad settings for ICB lines. For host lines, operating company personnel set padding in the DMS-100 switch through tables LNINV and PADDATA. For channel bank lines, operating company personnel can set additional padding at the channel bank. Additional padding is set using dip switches or by entering pad settings at a channel bank interface terminal. Therefore, total padding for channel bank lines is the total of the padding entered in the DMS-100 switch and the padding set at the channel bank. An example follows to explain padding for channel bank lines.

Example

The following apply to this example.

- originator (line 1)
 - has 0 dB set at the channel bank in the transmit direction
 - has the pad group UNBAL entered in table PADDATA with a 2 db loss
 - has 0 dB set at the channel bank in the receive direction
- termination (line 2)
 - has 6 dB loss set at the channel bank in the transmit direction
 - has the pad group STDLN entered in table PADDATA with a 2 db loss
 - has 3 dB loss set at the channel bank in the receive direction

As shown in the following figure, line 1 originates a call. The channel bank applies 0 dB to the line. Therefore, no padding is applied to the line in the transmit direction. The DMS-100 switch applies a 2 dB loss on the line in the

SMA ICB Links (continued)

1TO2 direction because pad group UNBAL was entered for PADGRP1. An example of the tuple used in table PADDATA follows.

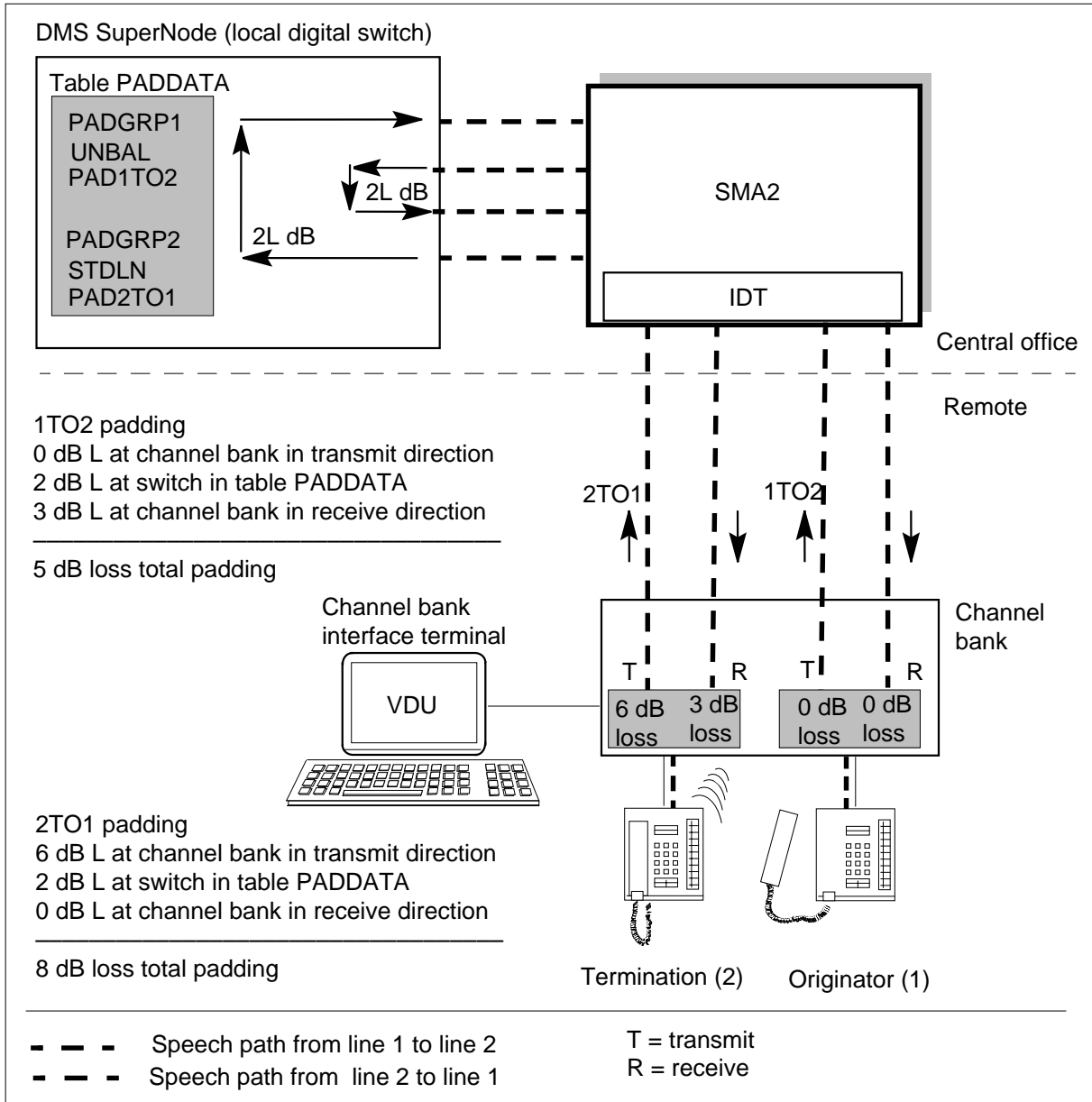
TABLE	PADDATA	PADKEY	PAD1TO2	
PAD2TO1	-----	-----	-----	UNBA
L	STDLN	2L	2L	

The channel bank applies a 3 dB loss to the line in the receive direction. Therefore the total padding applied to the line in the 1TO2 direction is a 5 dB loss.

For speech in the 2TO1 direction on the same call, the transmit side of the channel unit applies a 6 dB loss. The system applies a 2dB loss on the line because pad group STDLN was entered for PADGRP2. The channel bank applies no padding in the receive direction. Therefore, the total padding on the call in the 2TO1 direction is an 8 dB loss.

SMA ICB Links (continued)

Example of how padding is set for a channel bank line



Translations table flow

The SMA ICB Links translations tables are described in the following list:

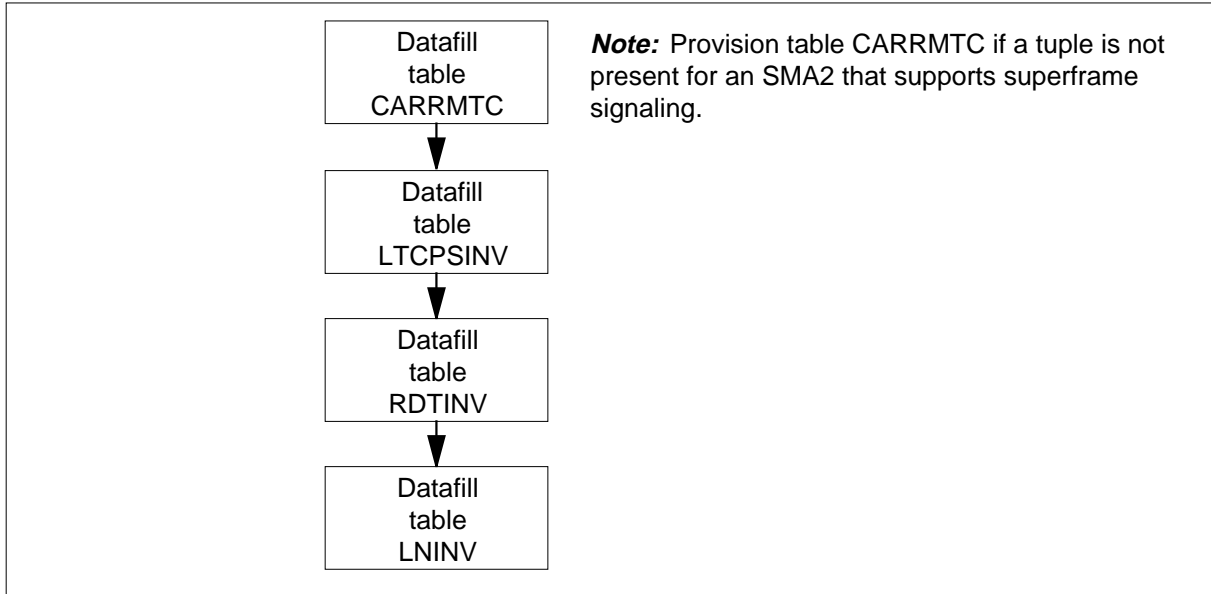
- table CARRMTC
- table LTCPSINV

SMA ICB Links (continued)

- table RDTINV
- table LNINV

The SMA ICB Links translation process appears in the following flowchart.

Table flow for SMA ICB Links



SMA ICB Links (continued)

The datafill content used in the flowchart appears in the following table.

Datafill example for SMA ICB Links

Datafill table	Example data
CARRMTC	SMA2 SFZCS 255 255 DS1 NTMX81AA MU_LAW SF ZCS BPV NILDL N 250 1000 1000 1000 150 1000 3 6 864 320 17 511 4 255
LTCPSINV	SMA2 0 Y (0 DS1 DEFAULT N) (1 DS1 DEFAULT N) (2 DS1 DEFAULT N) (3 DS1 DEFAULT N) (4 DS1 DEFAULT N) (5 DS1 DEFAULT N) (6 DS1 DEFAULT N) (7 DS1 DEFAULT N) (8 DS1 DEFAULT N) (9 DS1 DEFAULT N) (10 DS1 DEFAULT N) (11 DS1 DEFAULT N) (12 DS1 DEFAULT N) (13 DS1 DEFAULT N) (14 DS1 DEFAULT N) (15 DS1 DEFAULT N) (16 DS1 DEFAULT N) (17 DCH) (18 DS1 DEFAULT N) (19 DS1 DEFAULT N) (20 DS1 DEFAULT N) (21 DS1 DEFAULT N) (22 DS1 DEFAULT N) (23 DS1 DEFAULT N) (24 DS1 DEFAULT N) (25 DS1 DEFAULT N) (26 DS1 DEFAULT N) (27 DS1 DEFAULT N) (28 DS1 DEFAULT N) (29 DS1 DEFAULT N) (30 DS1 DEFAULT N) (31 DS1 DEFAULT N) (32 DS1 SFZCS N) (33 DS1 DEFAULT N) (34 DS1 DEFAULT N) (35 DS1 DEFAULT N) (36 DS1 DEFAULT N) (37 DS1 DEFAULT N) (38 DS1 DEFAULT N) (39 DS1 DEFAULT N) (40 DCH) (41 DCH) (42 DCH) (43 NILTYPE) (44 NILTYPE) (45 NILTYPE) (46 NILTYPE) (47 NILTYPE) (48 NILTYPE) (49 NILTYPE) (50 NILTYPE) (51 NILTYPE) (52 NILTYPE) (53 NILTYPE) \$
RDTINV	CARY 09 0 90 SMA2 0 2 \$ \$ \$ ICB N NA \$ (1 32)\$ N STDLN N
LNINV	CARY 09 0 01 02 RDTICB STDLN HASU N NL N ICB FXS

Limitations and restrictions

The following limitations apply to SMA ICB Links:

- The SMA2 supports a maximum of 48 DS-1s and a maximum of 5376 total lines.
- The SMA2 supports a maximum of 1152 ICB lines.
- The ICBs can be provisioned on SMA2 peripherals, and not on SMAs.
- Operating company personnel can provision a maximum of 1000 line controlling devices (LCD) on a DMS-100 SuperNode switch. An ICB is a type of LCD.
- The TR-303 message or object provisioning associated with other IDT types is not provided for ICB variants.
- Channel bank configuration for the ICB application must support on-hook transmission. This event must occur so that the DMS-100 SuperNode switch can support custom local area signaling services (CLASS) and

SMA ICB Links (continued)

Analog Display Services Interface (ADSI) display services. To support ADSI, an NTMX76CA must be provisioned in the SMA2.

- Frequency selective ringing (FSR) is not supported on ICBs.
- FXS signaling is the protocol that ICB lines associated with IDTs use. The FXS loop start and FXS ground start or voice path signaling must support the services this feature supports. Because FXS signaling does not support a battery reversal, line class codes and features that require a battery reversal are not supported. ISDN and Meridian business set (MBS) are not supported. The message waiting lamp is not supported.
- Extended superframe signaling is supported on ICBs only if four-state signaling (AB bit scanning) is used. Sixteen-state signaling (ABCD scanning) is not supported. This means individual channel yellow alarms and alarm indication signal (AIS) are not supported on the ICB interface because these capabilities require sixteen-state signaling.
- When ESF is used for an ICB interface, the data link (DL) is not supported. No DL commands are recognized by the ICB interface.
- The SMA2 does not support facility protection switching.
- FXS lines use the preferred sequential channel number assignment.
- The ICB supports up to four DS-1 links. One channel bank connects to each DS-1. You cannot busy the last DS-1 link on an ICB unless the ICB IDT is manually busy.

Interactions

The SMA ICB Links does not have functionality interactions.

Activation/deactivation by the end user

The SMA ICB Links does not require activation or deactivation by the end user.

Billing

The SMA ICB Links does not affect billing.

Station Message Detail Recording

The SMA ICB Links does not affect Station Message Detail Recording.

Datafilling office parameters

The SMA ICB Links does not affect office parameters.

SMA ICB Links (continued)

Datafill sequence

The tables that require datafill to put into operation SMA ICB Links appear in the following table. The tables appear in the order you must enter the data.

Datafill tables required for SMA ICB Links

Table	Purpose of table
CARRMTC	Carrier maintenance control. Allows the DMS switch administration to enter maintenance control information in peripherals, out-of-service limits, alarms and system return-to-service occurrences.
LTCPSINV	Line trunk controller P-side line inventory. Identifies the SMA2 module type, number and port designation of the P-side links.
RDTINV	Remote digital terminal inventory. Allows the DMS switch administration to enter data in remote digital terminals (RDTs) and the IDTs that correspond. This table contains the central side (C-side) connectivity information and RDT configuration information.
LNINV	Line circuit inventory. Retains an inventory of subscriber lines and associated line cards.

Datafilling table CARRMTC

Table carrier maintenance (CARRMTC) allows the DMS-100 SuperNode switch administration to perform the following:

- enter maintenance control information in peripherals
- enter out-of-service limits for alarms
- enter system return-to-service occurrences

Table CARRMTC contains the attributes of DS-1 links. These attributes include the line coding and frame formats, and maintenance control information.

A carrier maintains communication on links that connect the following:

- DMS peripherals to the channel banks
- DMS peripherals to remote DMS peripherals
- remote-to-remote DMS peripherals

A maximum of 16 entries are present in table CARRMTC for each type of peripheral. These peripherals can provide carrier links in the switch. Use these entries when you enter data in field CARRIDX of table LTCPSINV when data for carriers.

SMA ICB Links (continued)

When the first channel bank is provisioned on an SMA2, you must add a tuple to table CARRMTC. This action allows superframe (SF) or extended superframe (ESF) signaling on the DS-1 that connects to the channel bank. FXS signaling for loop and ground start lines from channel banks requires SF or ESF signaling.

The following checks are made between table CARRMTC and table LTCPSINV:

- Data entry can occur in a carrier index (CARRIDX) in table LTCPSINV. When this event occurs, an entry for the PM type must be present in table CARRMTC. The PM type is the SMA2 in this condition.
- When an entry deletion occurs from table CARRMTC, the carriers in table LTCPSINV cannot reference the entry. The system rejects the deletion command when the carriers reference the entry.
- A current entry in table CARRMTC can change. When this event occurs, the system checks table LTCPSINV to determine if in-service carriers reference the entry. When the carriers reference the entry, the system rejects the change command. A list of in-service carriers appears.

The DMS SuperNode switch adds the first tuple for an SMA2 to table CARRMTC during initial program load (IPL) or first restart after IPL. The entry is index 0 and has the value DEFAULT in the TMPLTNM field. The entry has default values for other fields.

You cannot delete this tuple. Fields ES, SES and thresholds for frame and slip losses can change. Manually add tuples that are not the default before the tuples can be referenced in table LTCPSINV.

You can delete these tuples when DS-1 carriers are not associated with the tuples. You can change tuples in table CARRMTC when the associated DS-1 carriers are manually busy or offline.

SMA ICB Links (continued)

The datafill specific to SMA ICB Links for table CARRMTC appears in the following table. Only the fields that apply directly to SMA ICB Links appear.

Datafilling table CARRMTC (Sheet 1 of 4)

Field	Subfield	Entry	Explanation and action
CSPMTYPE		SMA2	C-side node PM type. Enter the PM type of the node on the C-side of the carrier link.
TMPLTNM		SFZCS	<p>Template name. Enter the template name for the PM. The template name can be a maximum of 16 characters. This entry appears in the field CARRIDX of table LTCPSINV. The default value is DEFAULT.</p> <p>The value required to support ICBs is the template name that identifies the values entered in field ATTR, subfield FF as SF and subfield ZLG as ZCS for superframe format. For extended superframe format, subfield FF as ESF and subfield ZLG as B8ZS</p> <p>The example here is SFZCS.</p>
RTSML		0-255	Return to service maintenance limit. Enter the number of times in the audit interval that the system can return a carrier to service. The system issues a warning after the number of carrier RTSs exceeds this limit. Value 255 disables this feature.
RTSOL		0-255	Return to service out-of-service limit. Enter the number of times in the audit interval that the system can return to service a carrier. The system places the carrier out of service after the number of carrier RTSs exceeds this limit. Value 255 disables this feature.
CONTMARK		+	Continuation mark. Enter + for record to be continued on the next line.
ATTR		see subfield	Attribute. This field contains subfield SELECTOR.
	SELECTOR	DS1	Selector. Enter carrier type DS1.

SMA ICB Links (continued)

Datafilling table CARRMTC (Sheet 2 of 4)

Field	Subfield	Entry	Explanation and action
	CARD	NTMX81AA	Card. Enter the product engineering code (PEC) of the DS-1 interface card in use. The PEC for the DS-1 interface card in the SMA2 is NTMX81AA. The NTMX81AA provides 64 kb/s clear-channel ability required for MBS services that operate in B8ZS mode.
	VOICELAW	MU_LAW	Voice law. Enter the voice law in use in the carrier. International switches use the value A_LAW. North American switches use MU_LAW.
	FF	SF	Frame format. Enter super frame format (SF) or extended superframe format (ESF) in this field.
	ZLG	ZCS	Zero logic. Enter ZCS for zero code suppression for SF signaling. A byte of zeroes is transmitted with a 1 in the least significant bit position. This action results in a transmission that is wrong for data in the SMA2-RDT subsystem. This action causes minor noise for speech. The ZCS precludes the use of integrated services digital network (ISDN). Enter B8ZS for bipolar 8-bit zero substitution for ESF signaling.
	BERB	BPV	Bit error rate base. Enter BPV for bipolar violation.
	DLK	NILDL	Data link. Only NILDL is supported.
	IAT	N	Inhibit alarm transmit. Enter N for the IAT field for the SMA2-RDT configuration.
	LCGAST	250	Local carrier group alarm set threshold. Enter value for the threshold in units of 10 ms. The recommended entry is 250. The range is 0-9999.
	LCGACL	1000	Local carrier group alarm clear threshold. Enter value for the threshold in units of 10 ms. The recommended entry is 1000. The range is 0-9999.

SMA ICB Links (continued)

Datafilling table CARRMTC (Sheet 3 of 4)

Field	Subfield	Entry	Explanation and action
	RCGAST	1000	Remote carrier group alarm set threshold. Enter value for the threshold in units of 10 ms. The entry is a multiple of 10. This field is set to 1000, which provides a threshold value of 10 000 ms or 10 s. This value overrides datafill. The range is 0-9999.
	RCGACL	1000	Remote carrier group alarm clear threshold. Enter value for the threshold in units of 10 ms. The entry is a multiple of 10. This field is set to 1000, which provides a threshold value of 10 000 ms or 10 s. This value overrides datafill. The range is 0-9999.
CONTMARK		+	Continuation mark. Enter plus sign (+) for record to be continued on the next line.
	AISST	1-9999	Alarm indication signal set threshold. Enter value for the threshold in units of 10 ms.
	AISCL	1-9999	Alarm indication signal clear threshold. Enter value for the threshold in units of 10 ms. The range is 1-9999.
	BEROL	3-6	Bit error rate out-of-service limit. Enter the bit error rate out-of-service limit expressed as the negative of the exponent of 10 (10E-n). For example, 3 represents a 1 in 1000 bit error rate.
	BERML	4-7	Bit error rate maintenance limit. Enter the bit error rate maintenance limit expressed as the negative of the exponent of 10 (10E-n).
	ES	0-9999	Error second threshold. Enter value for the threshold in units of 10 ms.
	SES	0-9999	Severe error second threshold. Enter value for the threshold in units of 10 ms.
	FRAMEML	0-9999	Frame maintenance limit. Enter the maintenance limit for frame loss.
	FRAMEOL	0-9999	Frame loss limit. Enter the out-of-service limit for frame loss. FRAMEOL must be larger than FRAMEML.

SMA ICB Links (continued)**Datafilling table CARRMTC (Sheet 4 of 4)**

Field	Subfield	Entry	Explanation and action
	SLIPML	0-9999	Slip maintenance limit. Enter the maintenance limit for slip.
	SLIPOL	0-9999	Slip out-of-service limit. Enter the out-of-service limit for slip. The SLIPOL must be larger than SLIPML.

Handling BpV

Bipolar violation (BpV) levels for the channel bank are hard-coded in SMA2 software. These levels determine 1E-3 for the out-of-service limit and 1E-6 for the maintenance (MTC) limit. The 1E-3 is a 1 in 1000 bit error rate.

When you enter DEFAULT in field TEMPLTNM, the system compares RDT BpV levels to these hard-coded values. This comparison determines when an alarm is raised.

You control the RDT BpV levels when you enter NO_YELLOW_ALM in field TEMPLTNM. When this event occurs, the system compares RDT BpV levels with the values in fields BEROL and BERMN. This comparison determines when an alarm is raised.

Datafill example for table CARRMTC

Sample datafill for table CARRMTC appears in the following example.

MAP example for table CARRMTC

```

CSPMTYPE TEMPLTNM RTSML  RTSOL                                ATTR
-----
SMA2 SFZCS 255 255 DS1 NTMX81AA MU_LAW SF ZCS BPV NILDL
N 250 1000 1000 1000 150 1000 3 6 864 320 17 511 4 255

```

Datafilling table LTCPSINV

The P-side links for each bay associated with an SMA2 unit in the line trunk controller P-side link inventory (LTCPSINV) lists

- PM type
- PM number
- port assignment

SMA ICB Links (continued)

Table LTCPSINV must list the port connected to the correct channel bank. Enter the value for the template name in table CARRMTC in field CARRIDX for the SMA2 where the channel bank connects.

Datafill for SMA ICB Links for table LTCPSINV appears in the following table. The fields that apply directly to SMA ICB Links appear.

Datafilling table LTCPSINV

Field	Subfield	Entry	Explanation and action
PSLNKTAB		see subfields	P-side link table. This field contains subfields EXP_PSIDES, PSLINK, PSDATA, AREASELCT, CARRIDX, ACTION and CONTMARK. Vector from 0-53.
	CARRIDX	SFZCS	<p>Note: Make changes to fields with multiple entries in the PROMPT mode.</p> <p>Carrier index. Enter the same value for the template name in table CARRMTC. The value you enter here can be a value added in table CARRMTC. You must add all names manually or by datafill groups, in table CARRMTC before the names are available in this index. Do not add DEFAULT in this table.</p> <p>The value required to support ICBs is the template name that identifies the value entered in field TMPLTNM in table CARRMTC. This value is SFZCS for purposes of illustration.</p>

Datafill example for table LTCPSINV

Sample datafill for table LTCPSINV appears in the following example.

SMA ICB Links (continued)**MAP example for table LTCPSINV**

LTCNAME	PSLNKTAB

SMA2 0	
Y (0 DS1 DEFAULT N) (1 DS1 DEFAULT N) (2 DS1 DEFAULT N)	
(3 DS1 DEFAULT N) (4 DS1 DEFAULT N) (5 DS1 DEFAULT N)	
(6 DS1 DEFAULT N) (7 DS1 DEFAULT N) (8 DS1 DEFAULT N)	
(9 DS1 DEFAULT N) (10 DS1 DEFAULT N) (11 DS1 DEFAULT N)	
(12 DS1 DEFAULT N) (13 DS1 DEFAULT N) (14 DS1 DEFAULT N)	
(15 DS1 DEFAULT N) (16 DS1 DEFAULT N) (17 DCH)	
(18 DS1 DEFAULT N) (19 DS1 DEFAULT N) (20 DS1 DEFAULT N)	
(21 DS1 DEFAULT N) (22 DS1 DEFAULT N) (23 DS1 DEFAULT N)	
(24 DS1 DEFAULT N) (25 DS1 DEFAULT N) (26 DS1 DEFAULT N)	
(27 DS1 DEFAULT N) (28 DS1 DEFAULT N) (29 DS1 DEFAULT N)	
(30 DS1 DEFAULT N) (31 DS1 DEFAULT N) (32 DS1 SFZCS N)	
(33 DS1 DEFAULT N) (34 DS1 DEFAULT N) (35 DS1 DEFAULT N)	
(36 DS1 DEFAULT N) (37 DS1 DEFAULT N) (38 DS1 DEFAULT N)	
(39 DS1 DEFAULT N) (40 DCH) (41 DCH) (42 DCH) (43 NILTYPE)	
(44 NILTYPE) (45 NILTYPE) (46 NILTYPE) (47 NILTYPE)	
(48 NILTYPE) (49 NILTYPE) (50 NILTYPE) (51 NILTYPE)	
(52 NILTYPE) (53 NILTYPE) \$	

Datafilling table RDTINV

The remote digital terminal inventory (RDTINV) table contains inventory data in the DMS-100 switching office. This data includes RDTs and the IDTs that correspond. This table contains the C-side connectivity information and RDT configuration information. An ICB is a type of RDT.

When you add an ICB to table RDTINV, the SuperNode switch software creates a corresponding IDT in the SMA2.

When you delete an ICB from table RDTINV it deletes the corresponding IDT. Table RDTINV creates an ICB as a remote to the SuperNode switch and defines its attributes.

SMA ICB Links (continued)

Limits on node connected to an SMA2

There are limits on the node configurations supported for a single SMA2. For the following discussion, nodes that use the TR-303 or AccessNode interface are RDTs. Nodes that use the interface defined in PUB 43801 are ICBs.

- A single SMA2 supports up to eight RDTs if none of the RDTs support ISDN lines
- A single SMA2 supports up to seven RDTs if one or more of the RDTs support ISDN lines
- The following formula defines how many ICBs an SMA2 can support

SMA2 node configuration formula

$$(RDTs \times 28) + (\text{single-link ICBs}) + (\text{multi-link ICBs} \times 4) = 240$$

- RDTs is the number of nodes provisioned on the SMA2 in table RDTINV with a VARTYPE of GENTMC or RFT
- single-link ICBs is the number of nodes provisioned on the SMA2 in table RDTINV with a VARTYPE of ICB and a LINK_CAPACITY of 1
- multi-link ICBs is the number of nodes provisioned on the SMA2 in table RDTINV with a VARTYPE of ICB and a LINK_CAPACITY of 4

Fragmentation of internal data tables can impact the number of nodes supported on an SMA2. This is not probable, but can occur after the following.

- RDTs and ICBs both exist on the same SMA2
- operating company personnel delete RDTs and then add them to the same SMA2 again

When fragmentation occurs, the maximum SMA2 node configuration defined in the formula above does not provision. Contact the next level of support.

SMA ICB Links (continued)

Datafill related to SMA ICB Links for table RDTINV appears in the following table. Only fields that apply directly to SMA ICB Links appear in the following table.

Datafilling table RDTINV (Sheet 1 of 5)

Field	Subfield	Entry	Explanation and action
RDTNAME		see subfields	RDT name. This is the key to this table. This name identifies the RDT to the system. This field contains subfields SITE, FRAME and UNIT.
	SITE	alphanumeric	Site. Enter the four-character site name assigned to the remote location. This entry must appear in table SITE.
	FRAME	0-511	Frame. Enter the logical frame number.
	UNIT	0-9	Unit. Enter the logical unit number. For ICBs, this value is always zero. Note: The unit number must be 0 for the IDT configured with EOC. When an S or O entry is in the RDTINV field EOC, the UNIT number entry in this field must be 0.
ADNUM		0-4095	Administration number. The Engineering and Administrative Data Acquisition System for Data Collection (EADAS/DC) uses this number to identify nodes in the DMS-100 Family switch. This number remains fixed over dump and restore.

SMA ICB Links (continued)

Datafilling table RDTINV (Sheet 2 of 5)

Field	Subfield	Entry	Explanation and action
IDTNAME		see subfields	<p>IDT name. This field identifies the SMA2 and the IDT to which the RDT connects. This field contains subfields XPMTYPE, XPMNO and IDTNO.</p> <p>Note 1: The IDT must be offline to change this field.</p> <p>Note 2: An attempt can occur to move an IDT from one SMA2 to another SMA2, and the SMA2 is in an overload condition. When this event occurs, the following warning message appears. This message informs operating company personnel that static data can require a manual update after the IDT moves.</p> <p>Warning: SMA2 <sma2_no> is in overload. Static data update may fail.</p> <p>Note: If the dynamic static data update fails, the following warning message displays:</p> <p>Warning: Additional Static data not updated for SMA2 <sma2_no> Unit <unit_no>.</p> <p>Note: When the dynamic static data update is successful, the following message appears:</p> <p>Warning: Additional Static data updates completed for SMA2.</p>
	XPMTYPE	SMA2	The XMS-based peripheral module type. This field identifies the type of peripheral where the RDT connects.
	XPMNO	0-127	XPM number. This identifies the SMA2 where the RDT connects.

SMA ICB Links (continued)

Datafilling table RDTINV (Sheet 3 of 5)

Field	Subfield	Entry	Explanation and action
	IDTNO	0-999	IDT number. This identifies the IDT where the RDT connects. Note: A deletion of the IDT cannot occur when lines attach to the IDT.
NENAME		\$	Source identifier. The external operation support system uses this identifier to identify the RDT. The range is 1 to 20 characters.
PRIMOPC		1-20 characters	Primary OPC identifier. A \$ is entered in this field to satisfy the table editor.
BACKOPC		1-20 characters	Backup OPC identifier. A \$ is entered in this field to satisfy the table editor.
VARTYPE		see subfield	Variant type. Indicates the type of integrated digital loop carrier. Field VARTYPE contains subfield RDTVAR.
	RDTVAR	ICB	RDT variable. Enter ICB for an integrated channel bank. Note: RDTVAR cannot change. Delete and add the tuple again.
	LINK_CAPACITY	1 or 4	Number of DS-1 links available to the ICB. Enter 1 for ICBs with one DS-1 link. Enter 4 for ICBs with more than one DS-1 link. 1 and 4 are the only valid values. This value is equal to the maximum number of entries for the ICB in LINKTAB.
CLAPDFLT		NA	Choose LAPD default. Specifies for the IDT to use default or optional LAPD parameters. Enter NA to indicate that a choice of default LAPD parameters does not apply to the ICB variant.
MTSTACPT		see subfield	Metallic test access point. This is the selector field that identifies types of metallic test access (MTA) points, configured on the RDT. A \$ is entered in this field to satisfy the table editor.

SMA ICB Links (continued)

Datafilling table RDTINV (Sheet 4 of 5)

Field	Subfield	Entry	Explanation and action
NTTOPT		N	<p>No test trunk signature option. This field indicates when the no test trunk (NTT) direct current (dc) voltage signature is enabled for a specified RDT. When the value is Y, the dc signature for POTS, coin and multi-party lines is provided. When the value is not Y, the signature is not provided for the line types. Enter N for ICB configuration.</p> <p>Note: When an entry of N in the NTTOPT field occurs, the following message appears at the MAP terminal:</p> <pre>NTT signature will not be provided during line maintenance.</pre>
LINKTAB		numeric	<p>Link table. This is a vector with up to 28 entries. It defines the mapping of the C-side links (logical link) of the ICB to the P-side links (physical link) of the SMA2.</p> <ul style="list-style-type: none"> • Remote digital terminal link number (RDTLINK) is a value from 1 to 28 and represents the C-side link from the ICB. • Extended multiprocessor system-based peripheral module link number (XPMLINK) is a value from 0 to 47 and represents the P-side link. <p>Note: The number of entries in LINKTAB cannot exceed the number defined in LINK_CAPACITY.</p>
PROT		N	<p>Facility protection switching. Specifies if protection switching is supported.</p>
POTSPADG		STDLN	<p>The POTS pad group. The acceptable values are UNBAL and STDLN. Enter STDLN as a value.</p>

SMA ICB Links (continued)**Datafilling table RDTINV (Sheet 5 of 5)**

Field	Subfield	Entry	Explanation and action
EOC		see subfields	<p>Embedded operations channel. Indicates when EOC is present, and when standard or LAPD parameters are in use. This field contains subfields EOCTYPE and ELAPDPAR.</p> <p>Note: The IDT and the channel must be offline to change.</p>
	EOCTYPE	S, O, or N	<p>EOC type. Indicates when the EOC uses standard or optional LAPD parameters. Enter</p> <ul style="list-style-type: none"> • S for standard LAPD parameters. • O for optional LAPD parameters. The subfield ELAPDPAR appears. • N for no EOC channel, as for the ICB <p>For ICB configurations, the value of EOC is N.</p>
SDPOINTS		alphanumeric	<p>Signal distribution points. Enter the signal distribution point that corresponds to this RDT. A \$ is entered in this field to satisfy the table editor.</p>
RDTDN		see subfields	<p>RDT distinguished name. This is a vector of one to four elements for the RDT_RDN. Each element represents a relative distinguished name (RDN) that makes up the distinguished name of the RDT. Data is entered in this field when an RDT tuple is added. When an attempt to modify this field occurs, an error message is received.</p> <p>For an ICB, enter \$ in this field to satisfy the table editor.</p>

Datafill example for table RDTINV

Sample datafill for table RDTINV appears in the following example.

SMA ICB Links (continued)

MAP example for table RDTINV

RDTNAME	ADNUM		IDTNAME		NENAME			
	PRIMOPC				BACKOPC			
	VARTYPE			CLAPDFLT				MTSTACPT
NTTOPT								LINKTAB
PROT	POTSPADG			EOC				SDPOINTS
								RDTDN
RDT1	200 0	200	SMA2	0 200				\$
		\$						\$
ICB		4			NA			\$
	N							
			(1 32)	(2 37)	(3 35)	(4 36)		\$
N	STDLN				N			\$
								\$

Datafilling table LNINV

Enter data in subscriber lines that connect to the RDT in table line inventory (LNINV). This table defines the line equipment number (LEN) of a line and the hardware characteristics of the line.

Line equipment number definitions for ICBs

The LEN for ICB lines is defined with SITE, FRAME, UNIT, RDTLINK and CHANNEL. Values for the UNIT and RDTLINK subfields must match the RDTLINK value entered in the associated table RDTINV tuple. RDTLINK is a subfield of field LINKTAB in table RDTINV. The CHANNEL indicates the time slot assigned to the line.

The LEN is defined as follows:

- SITE - a four character definition of the ICB, for example, ICB1
- FRAME - a value from 0 to 511, for example, 1
- UNIT - this field limit is 0
- RDTLINK - a value from 1 to 4 that identifies the RDTLINK of the ICB that serves the line, for example, 3
- CHANNEL - a value from 1 to 24 that identifies the timeslot to which the line is assigned, for example, 10

SMA ICB Links (continued)

The definition of the previous determines that the LEN is ICB1 1 0 3 10.

Datafill specific to SMA ICB Links for table LNINV appears in the following table. The fields that apply directly to SMA ICB Links appear.

Datafilling table LNINV (Sheet 1 of 2)

Field	Subfield	Entry	Explanation and action
LEN		see subfields	Line equipment number. This field contains the following subfields: SITE, RDTFRAME, RDTUNIT, RDTSHELF and RDTSLLOT.
	SITE	alphanumeric	Site. Enter the location of the RDT, a four-character alphanumeric. This entry is not optional. There is no default value assigned to this entry.
	RDT FRAME	0-511	RDT frame. Enter the RDT frame number, which is not a frame. The number is a software entity that represents the group to which the RDT belongs at the site.
	RDT UNIT	0-9	RDT unit. Enter the number that represents the RDT unit in the group.
	RDTLINK	1-4	RDT link. Enter the number of the RDTLINK that connects the channel bank to the SMA2.
	CHANNEL	1-24	Channel. Enter the channel number that identifies the timeslot to the assigned line. The range is 1 to 24.
CARDCODE		RDTICB	Card code. Enter the PEC of the line card or line card carrier. The following identifies the respective object class type for the card code values represented: RDTICB integrated channel bank FXS line
PADGRP		STDLN, UNBAL, LRLM or NPDGP	Pad group. Enter the name of the pad group assigned to the line circuit in table PADDATA. Pads can be applied on the lines at the SMA2.
STATUS		HASU, WORKING, UNEQUIP, CUTOFF or RESERVED	Status. Enter the line inventory availability status.

SMA ICB Links (continued)

Datafilling table LNINV (Sheet 2 of 2)

Field	Subfield	Entry	Explanation and action
GND		Y or N	Ground. Where line is ground start, enter Y. Enter N for loop start.
BNV		L or NL	Balanced network value. Enter L when line circuit is configured for a loaded network. Enter NL for a network that is not loaded.
MNO		Y or N	Manual override. Enter Y when on-hook balance network test cannot update field BNV. Enter N to allow off-hook balance network test to update field BNV.
CARDINFO		ICB FXS	Card information. Enter the card information. The ICB is permitted when ICB is entered in table RDTINV, field VARTYPE. After ICB selection occurs, a subfield prompts for FXS.

Datafill example for table LNINV

Sample datafill for table LNINV appears in the following example.

MAP example for table LNINV

LEN		CARDCODE	PADGRP	STATUS	GND	BNV
MNO	CARDINFO					
RDT1	200 0 01 01	RDTICB	STD LN	WORKING	N	NL
N	ICB FXS					

Tools for verifying translations

SMA ICB Links does not use translation verification tools.

SERVORD

SMA ICB Links does not use SERVORD.

New SERVORD commands or options are not added for ICBs. The RDT-specific error responses to support ICBs are available.

The following line class codes are supported for ICBs:

- 1FR—one party flat rate
- 1MR—one party message rate
- 2WW—two-way wide area telephone service (WATS)

SMA ICB Links (end)

- CFD—coin free dialing
- EOW—enhanced outward WATS
- ETW—enhanced two-way line
- INW—incoming WATS
- OWT—outgoing WATS
- RES—residential enhanced services
- IBN—integrated business network

SERVORD limits

The following SERVORD limit applies to SMA ICB Links: AccessNode flow-through provisioning is not supported for ICB lines.

4 Remote Switching Center-SONET

Understanding RSC-S translations

This chapter describes the Remote Switching Center-SONET (Synchronous Optical Network) (RSC-S). This chapter reviews how to enter data in an RSC-S.

RSC-S development

A Remote Switching Center is a remote switching system that contains a family of advanced remote peripherals.

The Northern Telecom (NT) Digital Multiplex System-100 (DMS-100) Remote Access Family includes the Remote Line Concentrating Module (RLCM). The NT Digital Multiplex System-100 (DMS-100) Remote Access Family includes the Outside Plant Module (OPM) and the RSC. This product line extends DMS-100 central office features and services at a lower cost to subscribers in remote locations.

The RSC serves medium-sized remote applications. The RSC application flexibility qualifies the RSC for the following applications:

- community dial offices (CDO)
- private branch exchange (PBX) replacement
- central office capping
- medium-sized, single-, or multiple-customer business applications like integrated services digital network (ISDN) services

For businesses, the RSC delivers full Meridian Digital Centrex (MDC) feature transparency. The MDC feature transparency provides cost-effective networking for advanced business services. The RSC supports direct digital trunking to CDOs and PBXs. The RSC provides remote-off-remote configurations for the RLCM and OPM.

With FiberWorld, NT announced a network architectural direction. This direction offers operating companies the benefits of SONET interconnection, network simplification, and broadband-based services. The announcement

triggered important improvements to the RSC. These improvements allow operating companies to take advantage of FiberWorld benefits.

The SONET improvements to the RSC are packaged in the RSC-S.

RSC-S development schedule

The first phase of RSC-S includes base hardware and software for current RSC applications. Examples of new hardware developed at this stage includes nine circuit cards and the main shelf. This hardware is in the cabinetized Remote Switching Center (CRSC). The cabinetized extension module (CEXT) cabinet is included in phase 1 (BCS33). The CEXT includes a single shelf that contains two logical extension shelves and a DS60 extender with power supply.

As of BCS36, these cabinets contain the modular supervisory panel (MSP). During phase 1, the system implements dual remote cluster controller (DRCC) with peripheral side (P-side) interlinks. Phase 1 also supports the OPM and RLCM off of an enhanced remote cluster controller 2 (RCC2).

Note: For additional information on the phase development of this product, refer to the *Translations Guide*.

Differences between RSC and RSC-S

The RSC-S requires the same call processing software that an RSC uses. This software is a requirement for the installation of RSC-S. The RSC-S is an enhanced version of the RSC. New software functionality, revised system architecture, and component packaging results in improvements for phase 1.

Software functionality

Software features for the RSC-S are available through a group of standard RSC packages and the RSC-S basic package. The RSC packages provide each feature. The RSC-S basic package activates these features and provides all specified RSC-S capabilities. The RSC-S capabilities can use a digital signal 1 (DS-1) interface.

In addition to the improvement of RSC basic call processing, RSC-S provides improved capabilities for intraswitching and subtending remotes. The RSC-S feature provides improved capabilities for dynamic trunking, and emergency stand-alone (ESA) failure contingency services.

The improved capabilities for the BCS33 release include the following:

- Intraswitching allows calls that originate and terminate on the RSC-S to be switched without the use of host links.
- Remote-off-remote allows subtending remotes off the RSC-S.

- Dynamic trunking provides calls to and from subtending trunks that support CDOs and PBXs.
- The ESA allows service to continue in the RSC-S if the system loses communication with the host.

Revised system architecture

The RSC-S is based on the common peripheral module (CPM) architecture. The CPM replaces the current XMS-type expanded peripheral modules (XPM) for the host and remote applications. The CPM is a group of peripheral modules (PM) used in the DMS-100 family.

The CPM serves as a remote peripheral. An example of a remote peripheral is the RCC2. The RCC2 was introduced in BCS33. In remote applications, RCC2 supports several types of trunks and lines.

The RCC2 has the same amount of visibility and control as current XPMs have. The MAP terminal provides access to these PM types.

Note: The CPM does not require changes to line peripherals. The base CPM product is for the North American market.

The CPM is based on a two-shelf configuration that includes the RCC2 shelf and the extension shelf. The RCC2 shelf contains central processing equipment and circuits required for each application. The extension shelf contains octal T1 circuit cards and D-channel handlers (DCH). The extension shelf increases the capacity of the RCC2 shelf.

Package the CPM in a central office or customer location. Dual operation in remote applications and features is available to connect the two CPMs.

The following provisioning options are available for dual RCC2s (DRCC2):

- the SMS-R to digitally integrate the TR-008-compatible digital loop carriers
- the P-side DS-1 links for trunking
- central side (C-side) links for communication with the host

Packaging

The RSC-S packaging differs from traditional RSC packaging as follows:

- The RSC-S is provisioned in cabinets. The RSC-S is not provisioned in equipment frames.
- The RSC-S is based on the RCC2. The RCC2 is the master controller for all RSC-S peripherals. The RCC2 is a single-shelf module based on 68020 with increased processing capabilities.

- The core RSC-S cabinet contains a dual-shelf enhanced line concentrating module (LCME) or line concentrating module (LCM).
- An RSC-S extension cabinet is available to house additional ISDN DCH or DS-1 interfaces. The extension shelf contains one LCME.

The RSC-S can contain the following:

- a minimum of one or two CRSC cabinets
- a minimum of one cabinetized power distribution center (CPDC)
- one CEXT cabinet
- a maximum of five line concentrating equipment (CLCE) cabinets. The RSC-S can contain a maximum of ten CLCEs if the RSC-S is in a dual configuration.
- a minimum of one cabinetized miscellaneous equipment (CMIS) cabinets
- a cabinetized miscellaneous spares storage (CMSS) cabinet for spare card storage

A description of RSC-S component housing (CRSC, CPDC, CEXT, CLCE, CMIS, and CMSS) follows.

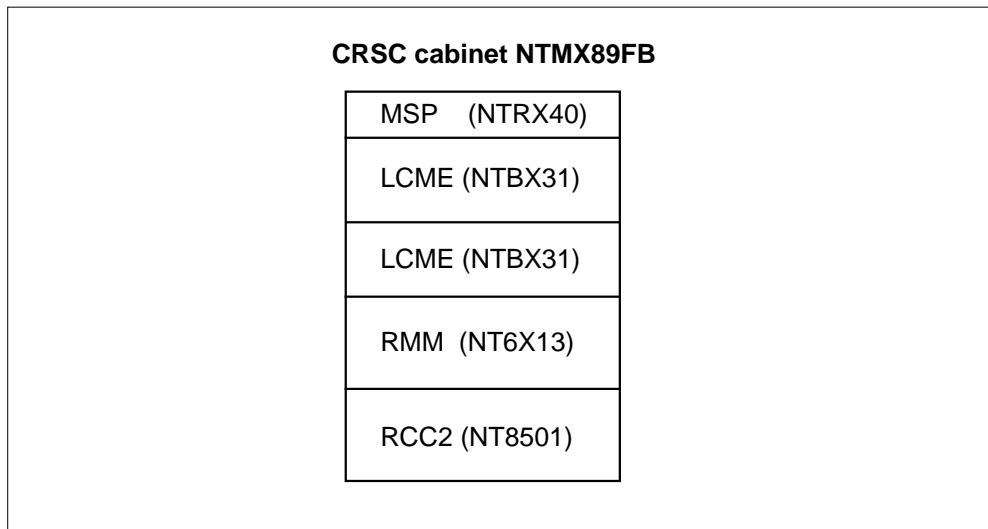
Cabinetized remote switching center cabinet

A single configuration RSC-S can have one CRSC cabinet that contains:

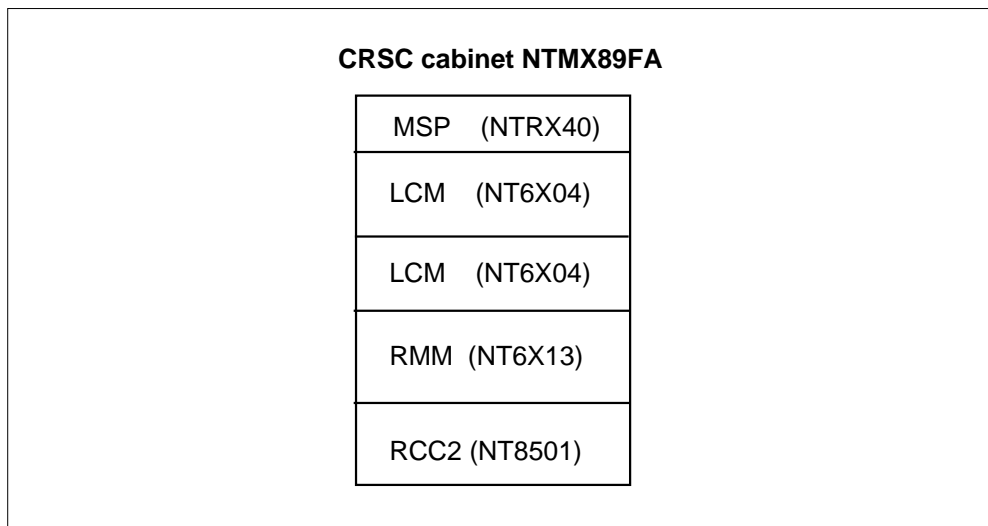
- an RCC2 shelf. This shelf is provisioned at all times.
- a remote maintenance module (RMM). Dedicated DS30A links serve this module.
- an LCM or LCME
- one of the following panels:
 - if model A, one frame supervisory panel (FSP)
 - if model B, one modular supervisory panel (MSP)

Note: A software upgrade does not occur on MAP displays. This condition indicates the difference between model A frame alarms and model B cabinet alarms. Both alarm types indicate FSP at the MAP terminal.

A CRSC cabinet provisioned with an LCME appears in the following figure.

Figure 4-1 CRSC cabinet

A CRSC cabinet provisioned with a LCM appears in the following figure.

Figure 4-2 CRSC cabinet with LCM**CRSC extension unit**

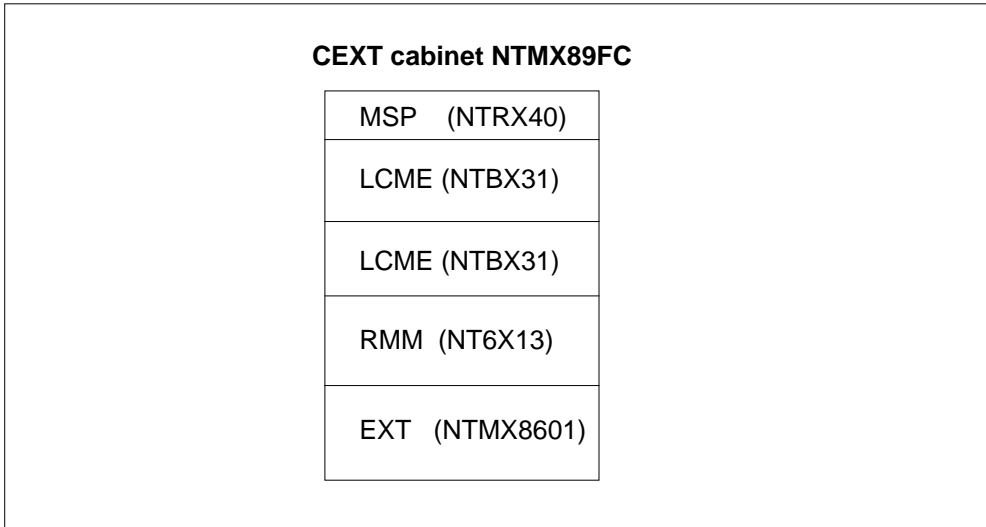
A single RSC-S configuration can have one CEXT cabinet that contains the following:

- an extension shelf (EXT)
- an RMM

- an LCME
- an MSP

A CEXT cabinet appears in the following figure.

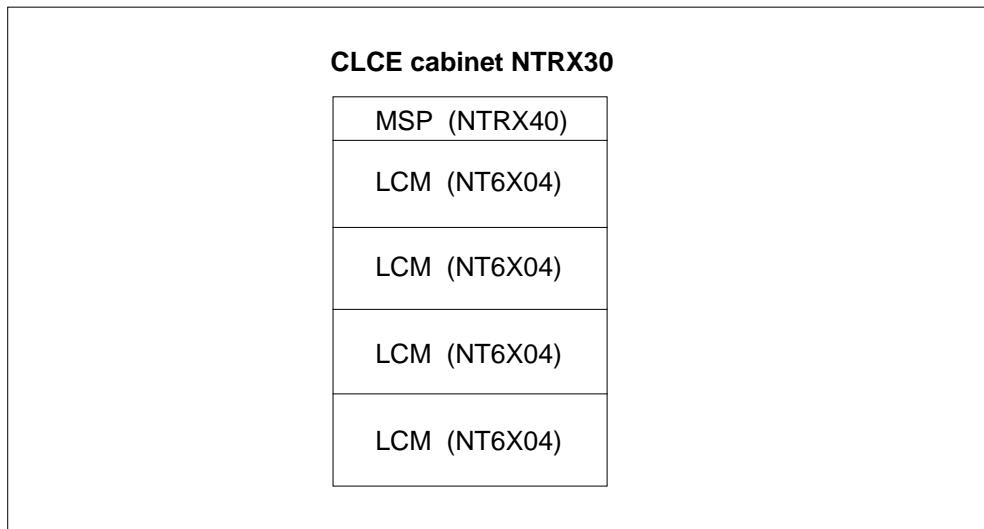
Figure 4-3 CRSC extension cabinet



Cabinetized line modules

A single configuration RSC-S can have a maximum of five CLCE cabinets. Each CLCE cabinet supports a maximum of two duplicated LCMs. Each duplicated LCM provides a 640 line card capacity.

A CLCE cabinet appears in the following figure.

Figure 4-4 Cabinetized line modules**Cabinetized power distribution center cabinet**

The CDPC is a cabinetized module that provides distribution of power for RSC-S equipment.

Cabinetized miscellaneous equipment cabinet

A single-configuration RSC-S can have one CMIS cabinet to house equipment specified for customers.

Cabinetized miscellaneous spares storage cabinet

A single-configuration RSC-S can have one CMSS cabinet for spare card storage.

RSC-S services

The RSC-S is diverse because of a flexible design. The RSC-S is diverse because of the wide range of interfaces and services that the RSC-S offers to operating companies. Examples of these services are:

- plain ordinary telephone service (POTS) 500/2500 sets
- multiparty lines
- coin lines
- the PBX interfaces
- the MDC 500/2500 sets
- Electronic business sets (EBS), P-phones
- the ISDN Basic Rate Access (BRA)
- Datapath/DIALAN

- attendant console
- Custom Local Area Signaling Services (CLASS)
- the DS-1-based local trunking
- enhanced Distance capacity
- National ISDN-1 (NI-1) compliance

The CPM in the same module can support the ISDN primary rate access (PRA). The ISDN PRA includes functional stimulus and Meridian feature transparency.

This range of options allows the RSC-S to address CDO modernization, business access remote, analog switch capping, and digital overlay networks.

NT offers the RSC-S with or without ISDN. The RSC-S with ISDN is based on the RSC-S that services business customers and residential subscribers. When operating company personnel add ISDN capabilities, increased services are available. For example, the RSC-S with ISDN can provide different POTS and MDC voice, data, and ISDN services.

The RSC-S provides NT compliance with the NI-1 range of services. The start of this is the BCS35. The NI-1 sets a standard protocol of designated ISDN services. The NI-1 provides terminal portability for the main switch manufacturers. The NI-1 is not supported during ESA operation.

The configuration of the RSC-S determines the services you can use with the RSC-S.

RSC-S configurations

The NT offers basic RSC-S and dual RSC-S, with or without ISDN. A description of the configurations for the RSC-S follows. A basic single RSC-S that does not have ISDN appears in the first figure. A dual RSC-S that does not have ISDN appears in the second figure. A basic single RSC-S with ISDN configuration appears in the third figure. The dual RSC-S with ISDN configuration appears in the fourth figure. The RSC-S currently supports the subscriber module SLC-96 remote (SMS-R). The SMS-R as a P-side remote off an RCC2 appears in all the figures.

Note: The Subscriber Carrier Module 100S Remote is another name for the SMS-R.

Figure 4-5 Basic single RSC-S configuration without ISDN

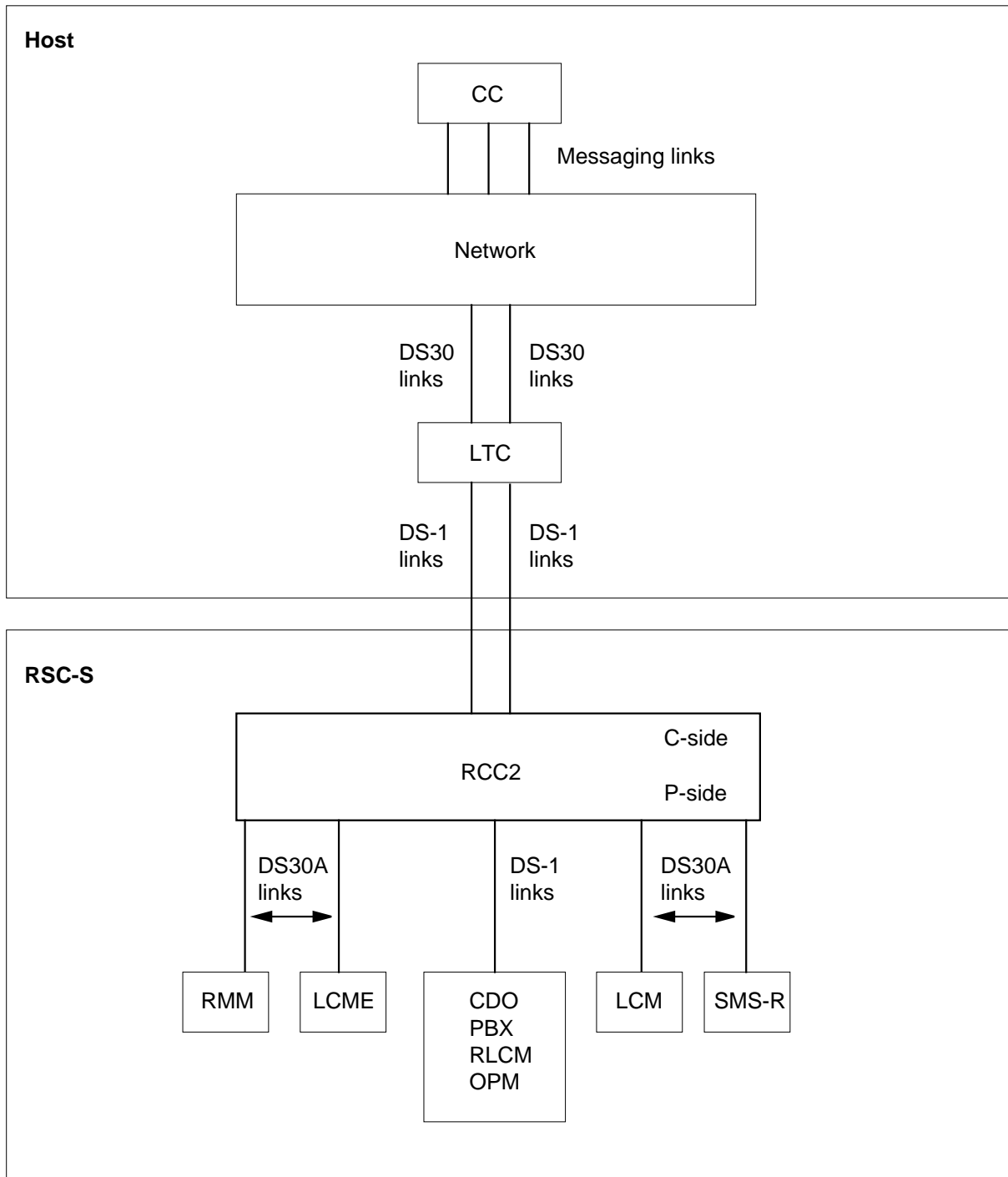


Figure 4-6 Dual RSC-S configuration without ISDN

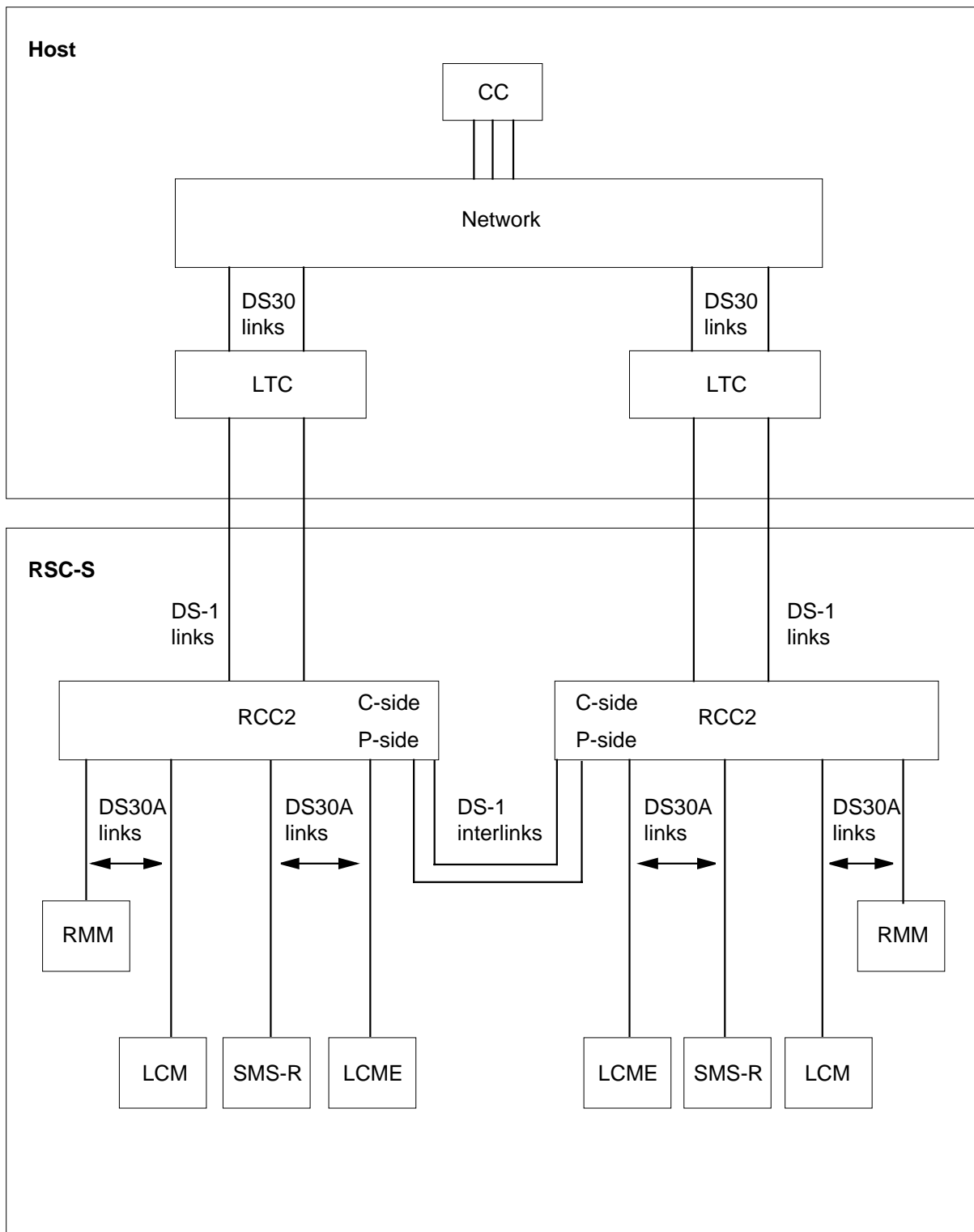


Figure 4-7 Basic single RSC-S with ISDN

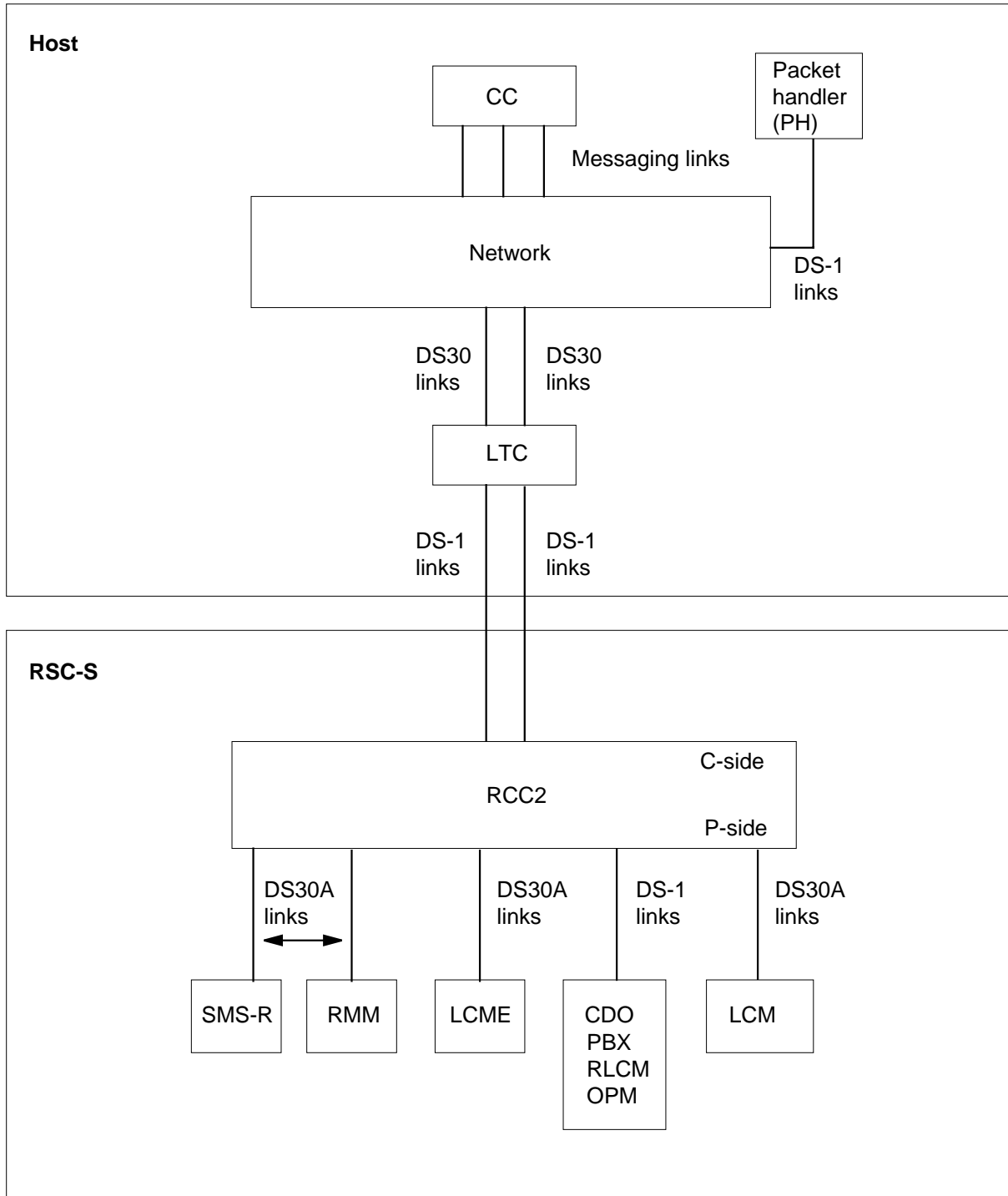
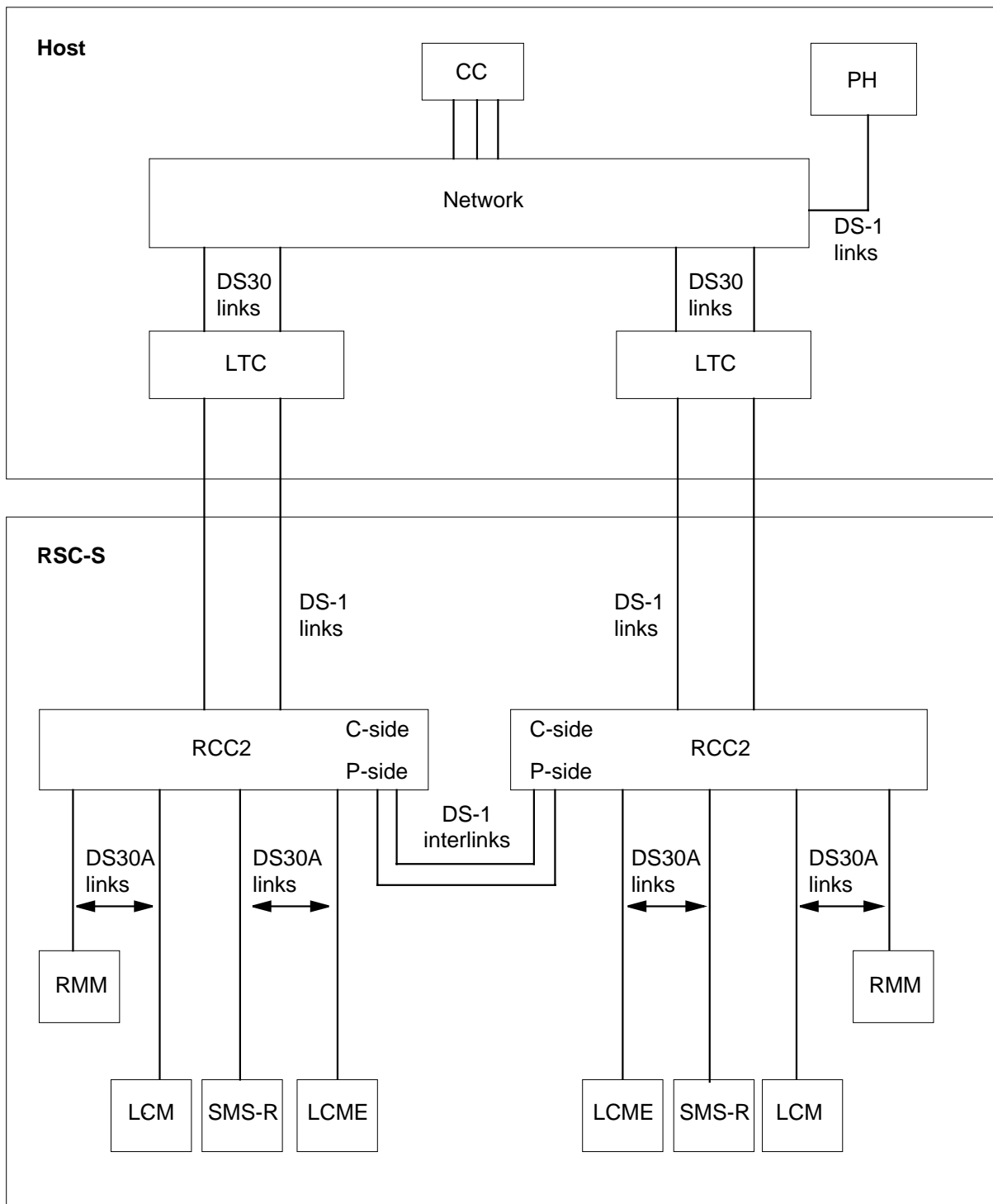


Figure 4-8 Dual RSC-S with ISDN



DS-1 electrical interface

The RSC-S can interface to a host DMS SuperNode. The electrical digital signal 1 (DS-1) facilities link an RSC-S to the host office. The DS-1 facilities are on the C-side of the RSC-S. The support lines for RSC-S electrical DS-1 applications terminate on a line group controller (LGC) at the host office. The DRCC2 includes two LGCs.

The support trunks and lines for electrical DS-1 applications of an RSC-S terminate on a line trunk controller (LTC) at the host. The host peripheral module can be a line trunk controller with ISDN (LTCI), or a line group controller with ISDN (LGCI).

When only lines are supported, the RSC-S connects to a DMS host office by the LGC over standard DS-1 electrical interfaces. When lines and trunks are supported, the RSC-S connects to an LTC over standard DS-1 electrical interfaces. The LTC is provisioned if an RSC-S must support trunks. The LGC can serve as the host peripheral if P-side RSC-S trunking originates *only* from an RLCM or OPM hosting off the RSC-S.

The system can locate an RSC-S with the current NTMX76 messaging and tone generating card. The system can locate this RSC-S at a maximum distance of 500 miles from the host office over DS-1 links. The NTMX76 card uses Signaling System No 7 (Q.703) over the data channels to improve distance capacity. The Q.703 is a full duplex, standard, common protocol. When the RSC-S is not a long distance remote, the NTMX76 card performs like the NTMX6X69 card. The NTMX76 card replaces the NTMX6X69 card.

Link capacity between an RSC-S and a host is from 2 to 16 DS-1s (382 DS-0s) for each RCC2. This capacity assumes a single DS-0 time slot for each service circuit. A dual configuration that assumes P-side interlinks, supports a maximum of 764 DS-0s to the host.

Each LTC must interface with only one RCC2. All DS-1 links from one RCC2 must terminate on the same LTC at the host. A DRCC2 requires an LTC in the host switch for each RCC2.

A DS-1 based T-carrier or digital microwave radio can perform transmission between an RSC-S and an LTC.

Quad pulse code modulation (PCM) carrier cards provisioned in the RCC2 shelf and the extension shelf provides the DS-1 interface. Each quad card contains a maximum of four DS-1 packets. Each packet provides two DS-1 interfaces. Each quad PCM carrier can have a maximum of eight DS-1 interfaces. The RCC2 can have a maximum of three quad cards (24 DS-1 interfaces). A maximum of three quad cards can be provisioned in the extension shelf. A total of 48 DS-1s can have the single RCC2 configuration.

Signaling for RSC-S

The common peripheral module (CPM) supports almost the same signal process and supervision functions as an XPM. The migration of an RSC-S to a CPM-based configuration causes differences.

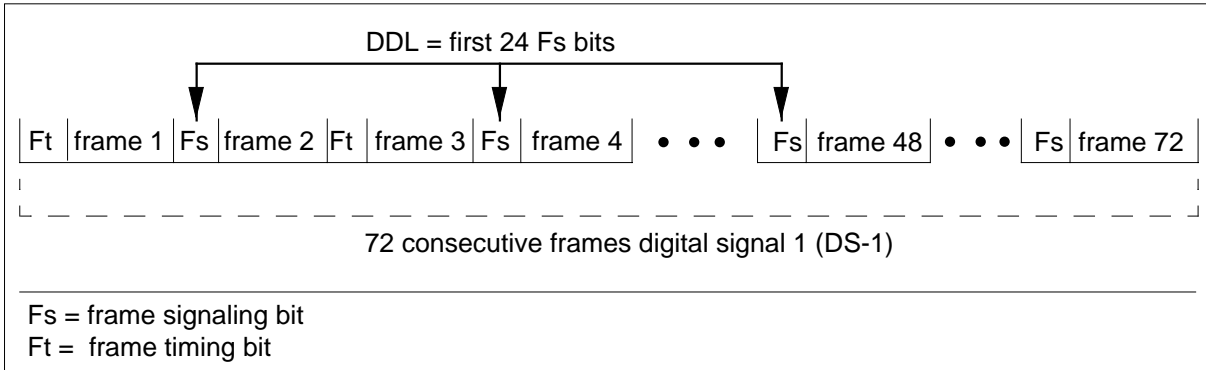
Signal additions

A facility data link is added as a part of the North America signal process through the use of the TR-303.

DDL signaling to SLC-96

A derived data link (DDL) connects a CPM to an SLC-96. The DDL message uses the first 24 of the 36 frame-signaling (Fs) bits in frames for the 72 DS-1. The format of the sync bits of 72 consecutive frames appears in the following figure.

Figure 4-9 DDL signaling format



Incoming DDL

The DS-1 interface (IF) card places a string of six consecutive DDL bits on the six most significant bits of TS7. The DS-1 card receives this string from DS-1s. The TS7 is on the DS30 line. The system updates TS7 at intervals of 12 frames.

Outgoing DDL

In transmission, a CPM places a 6-bit byte in every 12th frame on the TS7. The TS7 is from the matrix card. The CPM places this byte four times in 72 frames for a total of 24 DDL bits.

DDL for extended superframe

The DDL is exclusive to extended superframe (ESF) format.

DDL processing

The matrix switches all TS7s that come and go from the DS-1 IF to one DS60 digroup connected to the SIGP card. The signaling processor (SP) takes control after this switch occurs.

Table 4-1 DDL message bits and field names

DDL bits	Field name		Explanation
Bits 1-11	Concentrator field	(C-field)	Shelf groups AB and CD use the C-field when the shelf groups operate in Mode II. This field carries information for shelves A, B, C, and D. This information includes control of subscriber assignment and de-assignment to DS-1 channels, hook changes, and activation of the PCM looping test. Refer to note 1.
Bits 12-14	Spoiler bits pattern of 010)	(fixed	Spoiler bits are inserted at positions assigned in the DDL. This insertion prevents the duplication of the signaling pattern by the DDL.
Bits 15-17	Maintenance field	(M-field)	The M-field on the A-link carries information for all shelves. This field controls card and customer loop testing. Refer to note 2.
Bits 18-19	Alarm data link field	(A-field)	The A-field on the A-link carries alarm and system control information for all shelves. Refer to note 2.
Bits 20—23	Protection line switch field (S-field)		The S-field on the A-link controls the switching of the DS-1 protection link. Refer to note 2.
Bit 24	Spoiler bit field pattern of 1)	(fixed	The spoiler bit is inserted at the assigned position in the DDL. This insertion prevents the duplication of signaling patterns by the DDL.

Note 1: When a C-field is not available to send on the DDL link, the 8085 microprocessor sends an idle pattern on the DDL link. The RCS sends an idle pattern when a new C-field is not present.

Note 2: If the M-, A-, or S-fields do not change between messages, the 8085 microprocessor sends the previous field patterns. The RCS, at the other end, sends the same patterns. The 8085 microprocessor sends information to the SP only when a DDL field changes. The microprocessor does not transmit idle patterns.

Extended frame format

The design of the DS-1 extended frame format is 24 frames. The 24 synchronized bits have the following functions:

- six bits for framing pattern sequence
- twelve bits for facility data link
- six bits for cyclic redundancy check (CRC)

A 48-frame superframe is used between the matrix and the dual DS-1 IF card. The arrangement of facility data link information is as follows:

- Twenty-four received facility data link bits are available in three bytes.
- To transmit the 24 facility data link bits, the system writes three bytes in frames 1, 17, and 33.
- Read and write operations between the MTX and DS-1 IF cards occur through TS2.

The MTX concentrates all TS2s to a DS60 link for the SIGP.

SONET format

The SONET format uses a basic building block of synchronous transport signal level 1 (STS-1) with a bit rate of 51.84 Mb/s. Higher level signals are integer multiples of the base rate.

A synchronous signal is a quantity of 8-bit bytes organized in a frame 125 μ s in length. In the frame, the framing or marker bytes identify each byte.

In an STS-1 frame, the synchronous payload envelop divides in two areas, path overhead and payload area. The path overhead contains information on alarms and information to monitor performance. This information is necessary to support and maintain transport of the synchronous payload envelop between end locations. The payload area contains customer data.

An STS-1 payload contains a quantity of 774 bytes, arranged in 86 columns of 9 bytes. This area provides 49.54 Mb/s of transport capacity. This area carries a DS3 tributary signal at 44.376 Mb/s. Virtual tributaries are synchronous signals that transport low speed signals.

Note: One STS-1 can transport 28 DS-1s.

Preparing to datafill RSC-S

PCL—New Software Delivery Vehicle

Northern Telecom plans to deliver Product Computing-Module Loads (PCL) instead of BCS releases or Universal Software Loads (USL) after BCS36. A PCL contains features selected from the development stream software product intended for a specified application in a specified market. Previously, many related NTX packages shared the functions that the PCL can currently perform. An 8-digit ordering code replaces NTX package codes.

The ordering codes and functional group names that the RSC-S requires, appear in the following table. A list of previous NTX packages included in the

functional group appears in the following table. These capabilities are associated with the RSC-S.

Table 4-2 RSC-S ordering codes

Ordering code	Functional group name	Former NTX package codes
BAS00003	BAS Generic	NTX142AA—DS-1 64 Kb/s Clear NTX143AA—DS-1 ESF
BAS00012	BAS Remotes Generic	NTX145AA—Remote Switching Center NTX149AB—RSC ESA-Lines and Trunks NTX150AA—RSC-Intra RSC Calling NTX152AB—RSC Trunking NTX380AA—Dual Remote Cluster Controller NTX381AA—RSC Remote-Off-Remote NTXN82AB—RSC Enhanced ESA (Lines and Trunks) NTXP92AA—RSC-S Basic NTXQ12AA—RSC Enhanced ESA (Lines)
BAS00016	BAS SCM/SMS /SMU	NTXA85AB—Subscriber Carrier Module-SLC96 Base
NI000007	NI0 ISDN Base	NTX750AD—ISDN Basic Access

Collecting end-user data

When an RSC-S includes ISDN, gather profiles of subscriber sets. This action allows you to enter the subscriber sets for both the host office and the packet handler (PH).

Configurations

For BCS33 and higher, an RSC-S can be configured with or without ISDN. An RSC-S configuration contains a group of non-ISDN peripherals. This type of configuration allows the system to provide a wide range of services. The services the system provides do not include ISDN services. An RSC-S *with* ISDN offers all RSC-S services. This type of RSC-S can include all RSC-S peripherals. This configuration includes ISDN-type peripherals and offers ISDN services.

The type of configuration directly affects entry requirements. The configuration determines the services available with the RSC-S.

Overview of datafill requirements

Many aspects of datafill apply only to the functions of the RSC-S. The following sections describe these functions. These sections describe datafill tables and identify the location of information on procedures.

Activating the RSC-S

Enter the field operator verification common language location identifier (OPVRCLLI) in table CLLI first for RSC-S. This tuple in table CLLI forms a field in table SITE. Enter other tables in the order specified in the data schema section of the *Translations Guide*.

Datafilling dynamic trunks

The system assigns dynamic trunks for each trunk group. Table ISTRKGRP contains the CLLI of the trunk groups. The CLLI trunk group members are dynamic trunks. Follow normal datafill sequence for static trunks. Static trunks are trunks that the host assigns to channels. A section that follows in this chapter describes the datafill sequence for each trunk group type.

The RCC2 must perform call processing and maintenance for an RCC2 and the RCC2 subtending nodes. The RCC2 must recognize the system options the RCC2 contains. The RCC2 must recognize the P-side and central-side (C-side) link configurations. The system loads this information from the CC. This information is static data because the RCC2 cannot change this data. Dynamic data can change. This type of data includes call processing channels that change as calls are set up and broken down.

The DMS host and RCC2 must have the same static data. If the static data is not the same, the CC and RCC2 can have different configurations. The different configurations determine which C-side and P-side links are present. The different configurations can cause the system to lose calls. The following sections describe when and how to update static data. The update makes sure the RCC2 cannot process calls for a minimum time interval.

When to update the RCC2 static data

The update of static data in the RCC2 must occur under the following conditions:

- the system adds, changes, or deletes links on the RCC2 P-side or C-side in tables RCCINV, RCCPSINV, or LTCPSINV
- the system adds, changes, or deletes nodes off the RCC2 or the links associated with these nodes. You can change these nodes in tables LCMINV, RMMINV, or RCCPSINV.
- when the system adds, changes, or deletes cards in the card list of the RCC2 or nodes off the RCC2. You can change these cards in tables LCMINV, RMMINV, or RCCPSINV.

- add, change, or delete the exec data for the RCC2 in table RCCINV
- any global office parameters that affect the RSC-S configuration change
- You can set ESA to ON or OFF in table RCCINV.
- interlinks or field ESAFORCE in table IRLNKINV change

Alarms produced when a static data mismatch occurs

When the CC static data at the CC is complete, the system does not update the static data at the RCC2. The system generates a PM128 log with the following message:

```
STATIC DATA MISMATCH WITH CC
```

TUPC logs for static data updates

Journal files (JF) monitor changes in DMS data tables. These files monitor data modification orders (DMO) and service orders. When you reload an office, apply the JFs before you start a new JF. This action allows the JF to record data changes. The system produces a log that records changes in inventory tables. This log includes the following data tables:

- the LCMINV
- the LTCINV
- the LTCPSINV
- the RMMINV
- the RCCINV
- the RCCPSINV

The system generates the log for each tuple. The information in the log includes the table name, original tuple, and the tuple that results from the change.

Types of TUPC logs

The numbers for the TUPC (tuple change) logs appear as follows:

- the TUPC100. This log indicates that the system added a tuple.
- the TUPC101. This log indicates that the system deleted a tuple.
- the TUPC102. This log indicates that the system changed a tuple.

Note: This log contains the old tuple.

- the TUPC103. This log indicates that the system changed a tuple.

Note: This log contains the current tuple.

TUPC log format

The TUPC log contains a header that indicates the following:

- the log number
- the date
- the time
- the table name
- the action taken on the table. If you add to, change, or delete the table.

The important tuple or tuples appear in the log.

Note: The TUPC logs can help monitor inventory changes. Northern Telecom personnel must use the TUPC to solve field problems. Do not use this log in place of the JF utility.

SERVORD option NPGD for line cards NT6X18AA and NT6X18AB

The RSC-S contains line card types A and B, described as follows:

- standard line card type A (NT6X17AA, AB, AC, AD) or plain old telephone service (POTS) card
- line card type B (NT6X18AA, AB, BA) or COIN card

The RSC-S provides all features of type A. The RSC-S provides multiparty lines. This card supports the following:

- coded ringing
- private branch exchange (PBX)
- ground start
- hotel/motel
- analog pay telephone sets that require coin control

For NT6X18AA and NT6X18AB, use the service order (SERVORD) option negate partial ground start diagnostics (NPGD). The NPGD allows you to test the line against a smaller part of ground start diagnostics. When option NPGD is set in table LENLINES, the system omits loop detector, reversal relay, and ground start relay tests.

Note: This document does not include table LENLINES. For additional information about how to enter data in table LENLINES, refer to the data design section of the *Translation Guide*.

Examples of how to use SERVORD to add the NPGD in both prompt and non-prompt modes appears in the following section.

Figure 4-10 Example of adding the NPGD option in the prompt mode

```
>ADO
SONUMBER:      SR 12345 Q 95  4 13 PM
>
DN_OR_LEN:
>4817251
OPTION:
>NPGD
OPTION:
>$
```

Figure 4-11 Example of adding the NPGD option in the non-prompt mode

```
>ADO $ 4817251 NPGD $
```

Basic call processing

Functional group

BAS00012

Feature package

NTX145AA Remote Switching Center

NTX150AA RSC-Intra RSC Calling

NTXP92AA Remote Switching Center Basic

Release applicability

BCS20 and up for the Remote Switching Center feature package

BCS20 and up for the RSC-Intra RSC Calling feature package

BCS33 and up for the RSC-S Basic feature package

Prerequisites

Basic call processing requires the following feature packages:

- NTXR42AA Firmware Downloading
- NTX000AA Bilge
- NTX001AA Common Basic
- NTX145AA Remote Switching Center
- NTX269AA Universal Tone Receivers (Domestic)
- NTX270AA New Peripheral Maintenance Package
- NTX901AA Local Features I

Note 1: Feature packages NTXR42AA and NTX145AA are added as prerequisite packages for basic call processing in the Remote Switching Center-SONET (RSC-S).

Note 2: Feature package NTX381AA is removed from this list as a prerequisite feature package for basic call processing.

Description

Basic call processing for the RSC-S is obtained through a combination of software for DMS operation, standard RSC packages, and the RSC-S basic package. Individual features are provisioned through RSC packages, while the RSC-S basic package is used to activate these features and to provide all specific RSC-S capabilities.

Basic call processing (continued)

Basic call processing tables provide datafill for the following:

- DMS recognition of the switching unit and all remote locations
- physical device location identification data
- link assignments the RCC2 and peripherals
- recovery
- trunks and trunk groups
- alarm functions
- circuit test equipment
- maintenance control for peripherals

Physical device location identification data

Device location data for the major RSC-S components are located in inventory tables. These include tables LCMINV, RCCINV, and RMMINV.

Link assignments for the RCC2 and peripherals

Link assignments are datafilled in tables LTCINV, LTCPSINV, and RCCPSINV.

Recovery

Table PMLOADS stores the device location of every peripheral module (PM) load file in order to map between load names and devices on which the loads reside. This permits autoloading to locate load files without the intervention of personnel and autonomously reload PMs suspected of having a corrupt load.

DMS recognition of the switching unit and all remote locations

Table SITE contains data that allows the DMS system to recognize the equipment for the switching unit and for all remote locations that home on to it. This table defines the site names for the remote location. Table SITE uses codes entered in table CLLI for switching unit trunk groups and the remote location. Table CLLI uniquely identifies the far end of each announcement, tone, trunk group, test trunk, national milliwatt test lines, and service circuit.

Feature AF5678, XPM Node Table Sync Redesign, consolidates critical XPM node information in one table, PMNODES. To ensure XPM units maintain synchronization of internal node and port tables, the CM maintains a copy for each XPM unit. The XPM units do not have to derive any data for the internal node or port tables. The active XPM unit no longer updates the inactive unit

Basic call processing (continued)

tables which caused possible differences in the datafill of the tables. The CM downloads the same information to both XPM units during updates.



DANGER

An attempt to add or change tuples in any inventory table may be rejected by the system if table space or node resources are not available.

Attempted changes in the inventory tables with Table Editor may be rejected. The system displays an explanation and possible corrective actions. Usually BSYing and RTSing an XPM defragments the node tables, thus freeing required space. If XPM resources are not available, the following message is displayed.

The new node cannot be supported on <XPMNAME>
ACTION: None, resources have been exceeded on this XPM

Trunks and trunk groups

Tables TRKGRP, TRKSGRP, and TRKMEM define each trunk group associated with the switching unit, supplementary information for subgroups assigned to the trunk groups, and data associated with each trunk, trunk group, and subgroup. Other datafill identifies circuits associated with static trunks, dynamic trunks, and test equipment used to test lines and trunks.

Alarm functions

Tables ALMSCGRP, ALMSDGRP, ALMSD, and ALMSC record information for scan points and signal distribution points. This information includes circuit equipment, location, and type of circuit card for the scan point or signal distribution point. This datafill also includes the functions to be performed by each of the assigned scan points and signal distribution points in the alarm scan groups.

Circuit test equipment

Table TRKMEM identifies the circuits associated with static trunks, dynamic trunks, and test equipment used to test lines and trunks. Tables MTAMDRVE, MTAVERT, and MTAHORIZ include datafill for connecting test equipment to a circuit that requires testing.

Maintenance control for peripherals

Table CARRMTC datafill includes maintenance control information in peripherals, out-of-service (OOS) limits for alarms, and system return-to-service (RTS) occurrences.

Basic call processing (continued)

Operation

The RSC-S allows conditional routing. The SITE option is added to all plain ordinary telephone service (POTS) and integrated business network (IBN) call routing. The SITE option is datafilled as part of route selector CONDITION (CND) of tables IBNRTE, OFRT, and RTEREF subtables. The SITE option can be used with route types ST, SK, and T.

When the selector is set to CND, the following tables are affected:

For information on the following tables, refer to the *Translations Guide*.

- table IBNRTE
- table OFRT
- subtable HNPACONT.RTEREF
- subtable FNPACONT.RTEREF

The CND selector is required for conditional routes. Certain conditions must be specified before a call is routed. If the specified conditions are met, the instructions in the route list are executed. If the conditions are not met, translations looks to the next element in the route list. For a complete list and explanation of each routing condition, refer to the *Translations Guide*.

The SITE routing condition allows a call to be transferred to a route list or an element in a route list based on the call's origin. The site of the call's origin is compared with the site defined in the SITE field. If the two match, the call proceeds as indicated in the RTETYPE field and its refinements. Otherwise, the call proceeds to the next route element in the route list.

Note 1: Trunk groups must be unique by site and all members of each trunk group should belong to that specific site.

Note 2: Field SITE must be datafilled when CNDSEL equals SITE.

The following pages detail the fields datafilled in tables OFRT and IBNRTE for conditional routing. The fields in table OFRT are the same for subtable HNPACONT.RTEREF and for subtable FNPACONT.RTEREF.

Basic call processing (continued)

Table OFRT

The following table shows the datafill specific to Basic call processing for table OFRT. Only those fields that apply directly to Basic call processing are shown. For complete details on table OFRT, refer to the *Translations Guide*.

OFRT (Sheet 1 of 3)

Field	Subfield or refinement	Entry	Explanation and action
RTE		0 through 1023, or blank	Route reference index. Entry values: 1 through 1023, or blank. If the record is the first in the route list, enter the route reference number assigned to the route list. Otherwise, leave the entry blank. See note.
RTELIST		see subfields	Route list. Subfields: RTESEL and CND refinements CONDITION and CONDRTE.
	RTESEL	CND	Route selector. CND (conditional).
CONDITION	CNDSEL	see refinements	Condition. This field contains condition selector CNDSEL and refinements ALWAYS, CALLCHR, COSMAP, EA, INTERLATA, NRR, RND, SITE, TOD, TOPEAALT, TOPEACLS, TOPEAXFR, and SNPA. A match of the selected conditions affects transfer to the routing specified in field CONDRTE. If no match is made the call routing proceeds as specified in the next tuple.
	ALWAYS	ALWAYS	Always. Transfer to routing specified.
	CALLCHR	CALLCHR	The selected condition is a match of field CALLCHR. Use a call characteristic from table CALLCHR.
	COSMAP	COSMAP	The selected condition is a match to class of service map (COSMAP) field.
<p>Note 1: Enter a plus sign (+) for field CONTMARK when more data for the route list is specified on the next record. Enter a dollar sign (\$) for field CONTMARK when the record is the last for the route list.</p> <p>Note 2: The SITE field can only be datafilled after table SITE has been datafilled. Any entry in the SITE field must be defined already in table SITE.</p>			

Basic call processing (continued)**OFRT (Sheet 2 of 3)**

Field	Subfield or refinement	Entry	Explanation and action
CONDITION (continued)	EA	EA_CND_RTE	The selected condition is use equal access conditional routing, as defined in field EA_CND_RTE.
	INTERLATA		Index into table TRKLATA to obtain originating LATA of calling number. Index into table LATAXLA of called number to determine inter-LATA or intra-LATA status.
	NRR		
	RND	PERCENT	Enter percentage of calls that will be conditionally routed.
	SITE	SITE	The selected condition is a match of the site where the call originated.
	TOD	TODNAME, TIMES	TODNAME
	TOPEAALT		None
	TOPEACLS	TOP_CND_RTE	The selected condition is a match of the incoming call class-of-service to the entry in field TOP_CND_RTE.
	TOPEAXFR		Enter the selected TOPS class of service that the call should match.
	SNPA	SNPA_CND_RTE	
CONDRTE		see subfields	For each of the previous subfields (using route selector CND), field CONDRTE contains the following subfields: RTETYPE, RTEREF, SKIPNUM, EXTREID, TABNAME, and INDEX.
<p>Note 1: Enter a plus sign (+) for field CONTMARK when more data for the route list is specified on the next record. Enter a dollar sign (\$) for field CONTMARK when the record is the last for the route list.</p> <p>Note 2: The SITE field can only be datafilled after table SITE has been datafilled. Any entry in the SITE field must be defined already in table SITE.</p>			

Basic call processing (continued)**OFRT (Sheet 3 of 3)**

Field	Subfield or refinement	Entry	Explanation and action
CONDRTE (continued)	RTETYPE	ST, SK,T	Route type of the selected transfer. Refinements are another route list in the same table (ST), skip (SK) entries in route table, and route to specified table (T) and index. See the following entries.
	RTEREF	1 through 1023	ST. Same table specified. Enter in field RTEREF the number of the route reference element to transfer call routing.
	SKIPNUM	0 through 7	SK. Skip in same table specified. Enter field SKIPNUM the number of elements to skip in the route reference list.
	EXTREID	see subfields	T. Transfer to index in table specified. Subfields: TABNAME and INDEX. Do the next entries.
	TABNAME	OFRT, OFR2 OFR3, OFR4	Table name. Enter the office route table name.
	INDEX	1 through 1023	Index. Enter the route reference index number in the office route table.
<p>Note 1: Enter a plus sign (+) for field CONTMARK when more data for the route list is specified on the next record. Enter a dollar sign (\$) for field CONTMARK when the record is the last for the route list.</p> <p>Note 2: The SITE field can only be datafilled after table SITE has been datafilled. Any entry in the SITE field must be defined already in table SITE.</p>			

Field definitions for table OFRT

Use condition SITE in an RCS-S where trunks are connected to remotes creating a network of alternate routes for completing a call. The most efficient route for a specific call depends on the originator site. The originator site is compared with the site defined in subfield SITE. If the two match, the call proceeds according to field RTETYPE and its refinements. Otherwise, the call proceeds to the next route element in the route list.

Trunk groups must be unique by site and all trunk members of that trunk group should belong to the same site. Complete field CNDSEL by entering SITE as the type of condition to be tested. Complete field SITE by entering HOST or a site name known to table SITE.

Basic call processing (continued)

Routing options

Each of the formats with route selector CND point to the conditional route selector field CONDRTE. This field contains the following subfields.

- RTETYPE
- RTEREF
- SKIPNUM
- EXTREID
- TABNAME
- INDEX

Route to a specified route list in the same table

If a call is to be transferred to another route list in the same table, complete field RTETYPE by entering ST as the route type. Complete field RTEREF by entering the route reference number.

Route to a specified list in the same table

Field	Subfield or refinement	Entry	Explanation and action
RTETYPE		ST	Route type. Enter ST.
RTEREF			Route reference number. Enter the route reference number, which must be a higher index in the same table that translation refers to when the condition is met.

Route after skipping specified number of route elements

If call is to skip to another route element in the same route list, complete field RTETYPE by entering SK as the route type. Complete field SKIPNUM by entering the number of elements (0 through 7) to skip in the same route list where translations must route when the condition is met.

Route after skipping a specified number of route elements

Field	Subfield or refinement	Entry	Explanation and action
RTETYPE		SK	Route type. Enter SK.
SKIPNUM		0 through 7	Skip number. Enter the number of elements to skip in the same route list.

Basic call processing (continued)

Route to specified table at specified index

If call is to be transferred to another route list in table OFRT, complete fields RTETYPE and EXTREID. Field RTETYPE is completed by entering T as the route type.

Field EXTREID has two subfields, TABNAME and INDEX. Complete TABNAME by entering the table name OFRT where translation has to transfer when the condition is met. Complete INDEX by entering the route reference index number, 1 through 1023, in table OFRT where translation must transfer when the condition is met.

Note: Enter a plus sign (+) for field CONTMARK when more data for the route list is specified on the next record; enter a dollar sign (\$) for field CONTMARK when the record is the last for the route list.

If the call is to be transferred to another route list in table OFRT, complete field RTETYPE and field EXTRTEID as follows:

Route to specified table at a specified index

Field	Subfield or refinement	Entry	Explanation and action
RTETYPE		T	Route type. Enter T.
EXTREID			External route identifier. Subfields: TABNAME and INDEX.
	TABNAME		Table name. Enter the OFRT table name that a translation refers to when the condition is met.
	INDEX	1 through 1023	Route reference index. Enter the route reference index number in table OFRT that translation refers to when the condition is met.

Table IBNRTE

Table IBNRTE controls basic call processing as follows:

- when the IBN route selector is set to CND
- to route to a specified route list in the same table
- to route after skipping a specified number of route elements
- to route to a specified table at a specified index

This route selector is required for conditional routes. The route selector controls whether a call skips to another route list within the same table, skips a number of elements within the same route list, or transfers to a route list in a

Basic call processing (continued)

different route table. This action is based on whether the call meets one of six parameters including always, time of day, class of service, call characteristic, random, and site.

The following table provides field definitions for table IBNRTE.

IBNRTE

Field	Subfield or refinement	Entry	Explanation and action
RTE		numeric	Route reference index. If the record is the first on the route list, enter the route reference number assigned to the route list. Enter a value from 1 through 1023. Otherwise, leave the entry blank.
RTELIST		see subfields	Route list. Subfields: IBNRTESEL, CONDITION, and CONDRTE.
	IBNRTESEL	CND	IBN route selector. Enter CND.
CONDITION		see subfields	Condition. Subfields: CONDSEL, SITE, TODNAME, TIMES, COSMAP, and CALLCHR.
	CONDSEL	SITE	Condition selector. Enter SITE as the type of condition if the selection is based on origin.
	SITE	alphanumeric	Site. Enter the name of the site to be datafilled in table SITE for the selection.

Each of the previous formats with route selector CND contain field CONDRTE (conditional route). Field CONDRTE contains subfields RTETYPE, RTEREF, SKIPNUM, EXTRTEID, TABNAME, and INDEX.

If the call is to be transferred to another route list in the same table, complete subfield RTETYPE by entering ST as the route type. Complete subfield RTEREF by entering the route reference number (1 through 1023). The route reference number must have a higher index in the same table, where translations refers to when the condition is met.

Basic call processing (continued)

If the call is to be transferred to another route list in the same table, complete RTETYPE and RTEREF as follows:

Call transfer to a specified route list in same table

Field	Subfield or refinement	Entry	Explanation and action
	RTETYPE	ST	Route type. Enter ST.
	RTEREF	1 through 1023	Route reference number. It must be a higher number in the same table that translation refers to when the condition is met.

If the call is to skip to another route element within the same route list, complete subfield RTETYPE by entering SK as the route type. Complete subfield SKIPNUM by entering the number of elements (0 through 7) to skip within the same route.

If the call is to skip to another route element within the same route list, complete RTETYPE and SKIPNUM as follows:

Call skip to route element in same route list

Field	Subfield or refinement	Entry	Explanation and action
	RTETYPE	SK	Route type. Enter SK (skip).
	SKIPNUM	0 through 7	Skip number. Enter the number of elements to skip in the same route list that translation routes to when the condition is met.

If the call is to be transferred to another route list in table OFRT, complete subfields RTETYPE and EXTREID. Subfield RTETYPE is completed by entering T as the route type.

Subfield EXTRTEID is further divided into TABNAME and INDEX. Complete TABNAME by entering the OFRT table name where translation has to transfer when the condition is met. Complete INDEX by entering the route reference index number (1 through 1023) in table OFRT that translation refers to when the condition is met.

The SITE field can only be datafilled after table SITE has been datafilled. Any entry in the SITE field must be defined in table SITE.

Basic call processing (continued)

If the call is to be transferred to another route list in table OFRT, complete RTETYPE and EXTRTEID as follows:

Call transfer to another route list in table OFRT

Field	Subfield	Entry	Explanation and action
EXTRTEID	RTETYPE	T	Route type. Enter T.
		see subfields	External route identifier. Subfields: TABNAME and INDEX.
	TABNAME	OFRT	Table name. Enter OFRT, the table that translation transfers to when the condition is met.
	INDEX	1 through 1023	Route reference index. Enter the route reference number in table OFRT that translation refers to when the condition is met.

Datafill example for table IBNDATA

The following example shows sample datafill for table IBNDATA.

MAP display example for table IBNDATA

RTE	RTELIST	IBNRTSEL	CONDSEL	SITE
CONDRITE				
1	(CND SITE HOST ST 2)	(CND SITE REM1 ST 3)	(CNS SITE REM2 ST 4)	
2	(S N N N G0)	(S N N N G1)	(S N N N G2)	
3	(S N N N G1)	(S N N N G0)	(S N N N G2)	
4	(S N N N G2)	(S N N N G0)	(S N N N G1)	

The datafill in the MAP display example for table IBNDATA , route list 1, element 1 sends the call to route list 2 if the call origination is HOST. If the call originated at REM1, the Digital Multiplex System (DMS) sends the call to route list 3, if the call originated at REM2, the call is sent to route list 4.

Once the call has been sent to the appropriate route list, the first element in that route list is attempted. If that element fails, the DMS tries each successive element until the attempt is successful. For example, if a call originated at site REM1, the DMS sends the call to route list 3. The call will be sent over trunk group G1 because that is the first element in the route list and has priority. If trunk group G1 is unavailable, the call is sent out on trunk group G0.

Basic call processing (continued)

TRK111 Log-routing problems

A TRK111 log report is generated for routing related problems. For detailed information on the TRK111 log report, refer to *Log Report Reference Manual*.

OM GNCT route list not datafilled

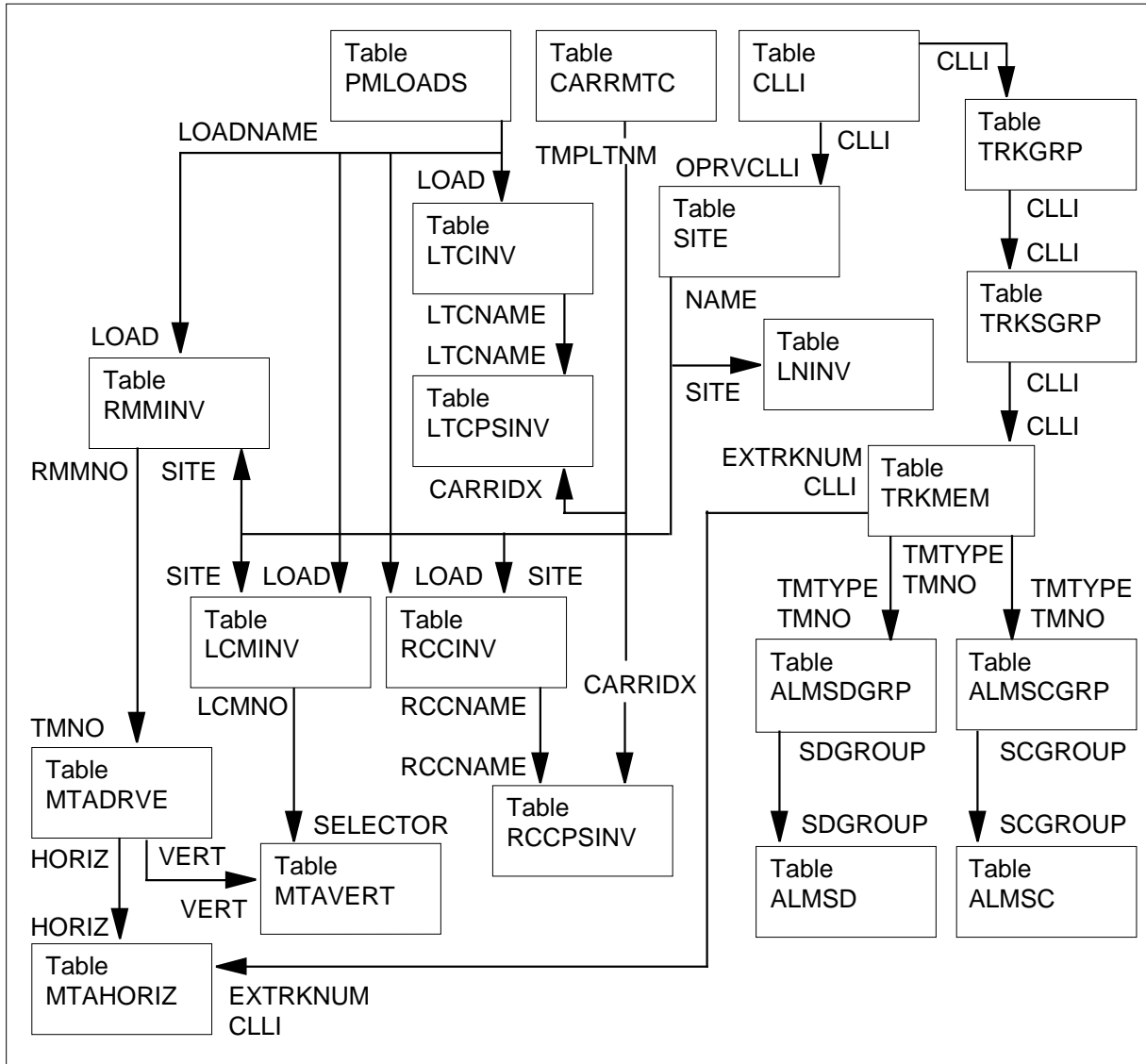
The GNCT register in operational measurement (OM) group TRMT2 is pegged for calls that attempt a route list that is not datafilled. For details on OMs, refer to the *Operational Measurements Reference Manual*.

Translations table flow

The Basic call processing translation process is shown in the flowchart that follows.

Basic call processing (continued)

Table flow for Basic call processing



The Basic call processing translations tables are described in the following list:

- Table MTAHORIZ lists the assignment of horizontal agents to a horizontal and horizontal group of MTAMs. Table MTAHORIZ uses CLLI codes from table CLLI for host and remote line test units, metallic test units (multiline), operator verification trunks, metallic jacks (MJACK) and incoming test access trunks. Field EXTRKNUM in this table is the external trunk number assigned to the line test unit or the metallic test unit. The

Basic call processing (continued)

EXTRKNM entry must correspond to an entry in table TRKMEM in field EXTRKNM.

- Table MTAVERT identifies the vertical connectivity to the MTA matrix. For RSC-S, the connection is single rather than multiple. Field SITE in table MTAVERT must correspond to field NAME in table SITE to identify the equipment for the switching unit and for all remote locations connected to it.
- Table MTAMDRVE locates an MTAM driver in the MTA structure. MTA is used to connect test equipment to a circuit that requires testing. The metallic test access (MTA) network is a matrix of vertical and horizontal crosspoints, comparable to a minibar, that connect specified verticals to horizontal within the network.
- Table ALMSC identifies the function to be performed by each of the assigned scan points in the alarm scan groups. Field SCGROUP identifies a scan group number and corresponds to the SCGROUP entry in table ALMSCGRP.
- Table ALMSD identifies the function to be performed by each of the assigned signal distribution points in the alarm signal distributor groups. Field SDGROUP identifies the circuit equipment, location, and type of circuit card containing signal distribution (SD) points. Field SDGROUP corresponds to an entry in table ALMSDGRP.
- Table ALMSDGRP records the circuit equipment, location, and type of circuit card containing signal distribution (SD) points. Datafill in field SDGROUP in table ALMSD should correspond to SDGROUP entries in table ALMSDGRP.
- Table ALMSCGRP records the circuit equipment, location, and type of circuit card containing scan points. Datafill in field SCGROUP in table ALMSC should correspond to SCGROUP entries in table ALMSCGRP.
- Table TRKMEM lists the data associated with each trunk assigned to one of the trunk groups and subgroups specified in tables TRKGRP and TRKSGRP. This table identifies the circuits associated with static trunks, dynamic trunks, and the test equipment used to test lines and trunks. Field CLLI in table TRKMEM corresponds to the CLLI code for the trunk group.
- Table TRKSGRP lists the supplementary information for each subgroup that is assigned to one of the trunk groups listed in table TRKGRP. Field CLLI in table TRKSGRP corresponds to the CLLI code for the trunk group.
- Table TRKGRP defines data for each trunk group associated with the switching unit. Field CLLI in table TRKGRP corresponds to the CLLI code for the trunk group.

Basic call processing (continued)

- Table LTGRP provides the capacity to define up to 32 LT groups. One of the groups is defined as ISDN. Field GROUP in table LTGRP corresponds to field LTGRP in table LTDEF.
- Table PMNODES is a read-only table containing information about all nodes in each XPM. Information is automatically added or changed as tuples are datafilled in inventory tables. During the One Night Process (ONP) software system loading, table PMNODES must be transferred before any hardware inventory tables.
- Table RMMINV identifies a remote RLCM, RSC-S, or Outside Plant Module (OPM) site with the frame type, frame number, floor, row, frame position, product engineering code (PEC), PM load and executive program loaded, and central side (C-side) PM attached to each remote maintenance module (RMM). Subfield SITENM in table RMMINV corresponds to field NAME in table SITE. This field identifies the equipment for the switching unit and for all remote locations connected to it. Field LOAD in table RMMINV corresponds to the LOADNAME tuple from table PMLOADS. This field stores the device location of each PM load file.
- Table LCMINV lists data assignments for each bay associated with a local line concentrating module (LCM) or remote LCM (RLCM) unit. Field SITE in table LCMINV corresponds to the NAME tuple from table SITE. This field identifies the equipment for the switching unit and for all remote locations connected to it. Field LOAD in table LCMINV corresponds to the LOADNAME tuple from table PMLOADS. This field stores the device location of each PM load file.
- Table RCCPSINV contains only the peripheral side (P-side) link assignments for the RCC2. When a tuple is added in table RCCINV, a corresponding tuple is added automatically in table RCCPSINV. This table uses field LOAD to identify load information. LOAD corresponds to the LOADNAME tuple from table PMLOADS. Field CARRIDX indexes into table CARRMTC for maintenance control information about peripherals. Also, the RCCNAME tuple in table RCCPSINV corresponds to the RCCNAME tuple from table RCCINV and stores site information, originally entered in field NAME from table SITE, the PM type, and PM number.
- Table RCCINV maintains a list of RCC2s that are datafilled in the DMS system and contains inventory data, except P-side link assignments, for the RCC2s. The table information identifies where the RCC2 is located, the load and exec lineups required, and the network link connections. C-side DS-1 assignments for the RCC2 are datafilled in table RCCINV. In addition, intraswitching is datafilled in table RCCINV.

Load information for this table is datafilled in field LOAD and corresponds to the LOADNAME tuple from table PMLOADS. Also, the RCCNAME

Basic call processing (continued)

tuple in table RCCINV corresponds to the RCCNAME tuple from table RCCPSINV. Field RCCNAME stores site information (originally entered in field NAME from table SITE), the PM type, and PM number.

- Table LTCPSINV contains the assignment of the P-side links for PMs. If DS-1 is datafilled, field CARRIDX indexes table CARRMTC for maintenance control information about the peripheral.
- Table CARRMTC allows the DMS switch administration to datafill maintenance control information in peripherals, out-of-service (OOS) limits for alarms, and system return-to-service (RTS) occurrences. The TEMPLTNM tuple in table CARRMTC corresponds to field CARRIDX in tables LTCPSINV and RCCPSINV.
- Table LTCINV contains the inventory data, except the P-side link assignment, for PM types. This table is used to define the line trunk controller (LTC)/line group controller (LGC) on the C-side of the RCC2. Load information for this table is datafilled in field LOAD and corresponds to the LOADNAME tuple from table PMLOADS.

Field LTCNAME in table LTCINV corresponds to field LTCNAME in table LTCPSINV.

- Table PMLOADS stores the device location of every peripheral module (PM) load file in order to map between the load names and devices where the loads reside. The PM load files must be datafilled in table PMLOADS before they can be used in the inventory tables.

Load information is datafilled in field LOADNAME and corresponding entries are datafilled in field LOAD for tables LTCINV, LCMINV, and RMMINV.

- Table SITE identifies the equipment for the switching unit and for all remote locations connected to it. This table must be datafilled before any LEN can be assigned or a PM can be datafilled. The host switching unit is the first entry in field NAME, then field LTDSN is associated with the number required to dial the site and alarm data for remote sites. Table SITE uses the same CLLI tuple for operator verification as the one datafilled in table CLLI.

Field SITE in table LCMINV, field SITENM in tables RCCINV and RMMINV, and subfield SITE_ID in table ISTRKGRP must be known to table SITE (field NAME).

- Table LNINV lists site name, the line equipment number, and associated data for each line card circuit in an office.
- Table CLLI uniquely identifies far end of the trunk group by the name of the city or town, the state or province, the building group, the destination of the traffic unit and the code identifying trunk groups that terminate at the

Basic call processing (continued)

same CLLI location. Table CLLI also stores the maximum number of trunk groups expected to be assigned to the trunk group and a miscellaneous entry for administrative information not used by the switching unit.

Some CLLI codes are added automatically to table CLLI when the feature is present in the switch. Other codes must be added to the CLLI table. After datafilling table CLLI, CLLI codes are reflected in trunk group tables, a scan and distribution point table, and MTA tables. The CLLI tuple for operator verification must be duplicated in field OPVRCLLI in table SITE.

Note: Some data tables must be datafilled according to the kind of trunk group type required. Each trunk group type requires a specific form. The valid trunk group types are TI, TO, T2, IBNTI, IBNTO, IBNT2, PX, and ES.

Limitations and restrictions

Basic call processing has no limitations or restrictions.

Interactions

Basic call processing has no functionality interactions.

Activation/deactivation by the end user

Basic call processing requires no activation or deactivation by the end user.

Billing

Basic call processing does not affect billing.

Station Message Detail Recording

Basic call processing does not affect Station Message Detail Recording.

Datafilling office parameters

Basic call processing does not affect office parameters.

There are no parameters specific to the basic RSC-S configuration. However, there are parameters associated with capabilities the RSC-S can have, such as emergency stand-alone (ESA). These capabilities are addressed in their respective chapters.

Control of routine exercise (REX) testing for line concentrating modules (LCM) is transferred from parameter LCDREX_CONTROL in table OFCVAR. Testing of LCM ring and voltage values, previously a section of

Basic call processing (continued)

LCM_REX, is separated into an LCM converter test (LCM_COV_REX). Control of LCM_REX_TEST and LCMCOV_REX_TEST, now part of system REX (SREX), is transferred to parameter NODEREXCONTROL in table OFCVAR. Parameter LCDREX_CONTROL is retained to control REX testing of line modules (LM).

Note: The LCMCOV_REX_TEST is performed only on LCMs, XLCMs, OPMs, and RLCMs.

The following table shows the office parameters used to control SREX test execution. For more information about office parameters, refer to *Office Parameters Reference Manual*. For information about SREX scheduling, refer to table REXSCHED in this document.

Office parameters used to control SREX execution

Table name	Parameter name	Explanation and action
OF CVAR	NODEREXCONTROL	Control of SREX nodes. Governs execution of all SREX tests (nodes). Fields: REXON (default: Y), REXSTART (default: 1:30), and REXSTOP (default: 3:30). Note: Individual REX test nodes are controlled by datafill in table REXSCHED.

Datafill sequence

The following table lists the tables that require datafill to implement Basic call processing. The tables are listed in the order in which they are to be datafilled.

Datafill tables required for Basic call processing (Sheet 1 of 3)

Table	Purpose of table
CLLI	Common Language Location Identifier. Common language location identifier (CLLI) codes uniquely identify the far end of each announcement, tone, trunk group, test trunk, national milliwatt test lines, and service circuit.
SITE	Site. Contains data that allows the DMS system to recognize the equipment for the switching unit and for all remote locations connected to it.
PMLOADS	Peripheral Module Loads. Stores the device location of every peripheral module (PM) load file to map between the load names and devices where the loads reside. This allows autoload to locate load files without personnel intervention. XMS-based peripheral module (XPM) load files must be datafilled in table PMLOADS before they can be used in the XPM inventory tables.

Basic call processing (continued)**Datafill tables required for Basic call processing (Sheet 2 of 3)**

Table	Purpose of table
PMNODES	Peripheral module node information. Read-only table automatically datafilled as tuples are datafilled in the inventory tables. Information from table PMLOADS is downloaded to all XPM units subtending the CM.
LTCINV	Line Trunk Controller Inventory. Contains PM inventory data, except the P-side link assignments. This table defines the line trunk controller (LTC)/line group controller (LGC) on the C-side of the RCC2.
CARRMTC	Carrier Maintenance Control. Allows DMS switch administration to datafill maintenance control information in peripherals, OOS limits for alarms, and system return-to-service (RTS) occurrences.
LTCPSINV	Line Trunk Controller P-side Inventory. Contains the assignment of the P-side links for XPM-type peripherals.
RCCINV	Remote Cluster Controller Inventory. Contains RCC2 inventory data, except P-side link assignments. RCC2 C-side DS-1 assignments are datafilled in table RCCINV.
RCCPSINV	Remote Cluster Controller P-side Link Inventory. Contains RCC2 P-side link assignments only.
LCMINV	Line Concentrating Module Inventory. Lists data assignment for each bay associated with a local LCM or RLCM unit.
RMMINV	Remote Maintenance Module Inventory. Identifies an RLCM, RSC-S, or OPM site with the frame type, frame number, floor, row, frame position, PEC, PM load and executive program loaded, and C-side PM attached to each remote maintenance module (RMM).
LNINV	Line Circuit Inventory. Lists the data for each line card slot.
REXSCHED	System REX scheduling. Schedules frequency and number of concurrent SREX tests. Used along with parameter NODEREXCONTROL in table OFCVAR to control the execution of all SREX testing. Tuples are automatically added to this table after inventory tables are datafilled.
TRKGRP	Trunk group. Defines data for each trunk group associated with the switching unit.
TRKSGRP	Trunk Subgroup. Lists the supplementary information for each subgroup assigned to one of the trunk groups listed in table TRKGRP.
TRKMEM	Trunk Member. Lists the data associated with each trunk assigned to one of the trunk groups and subgroups specified in tables TRKGRP and TRKSGRP. This table identifies the circuits associated with static trunks, dynamic trunks, and the test equipment used to test lines and trunks.

Basic call processing (continued)

Datafill tables required for Basic call processing (Sheet 3 of 3)

Table	Purpose of table
ALMSCGRP	Alarm Scan Group. Records the circuit equipment, location, and type of circuit card containing scan points.
ALMSDGRP	Alarm Signal Distributor Group. Records the circuit equipment, location, and type of circuit card containing signal distribution (SD) points.
ALMSD	Alarm Signal Distributor Group. Identifies the function to be performed by each of the assigned signal distribution points in the alarm signal distributor groups.
ALMSC	Alarm Scan. Identifies the function to be performed by each of the assigned scan points in the alarm scan groups.
MTAMDRVE	Metallic Test Access Minibar Driver. The metallic test access (MTA) network is a matrix of vertical and horizontal crosspoints, comparable to a minibar, that connect specified verticals to horizontal within the network. MTA is used to connect test equipment to a circuit that requires testing.
MTAVERT	Metallic Test Access Vertical Connection. Identifies the vertical connectivity to the MTA matrix.
MTAHORIZ	Metallic Test Access Horizontal Connection. Lists the assignment of horizontal agents to a horizontal and horizontal group of MTAMs.

Datafilling table CLLI

CLLI codes uniquely identify the far end of each announcement, tone, trunk group, test trunk, national milliwatt test lines, and service circuit.

Basic call processing (continued)

The following table shows the datafill specific to Basic call processing for table CLLI. Only those fields that apply directly to Basic call processing are shown. For a description of the other fields, refer to the *Translations Guide*.

Datafilling table CLLI for basic call processing (Sheet 1 of 2)

Field	Subfield or refinement	Entry	Explanation and action
CLLI		alphanumeric (16 characters maximum)	Common language location identifier. This sixteen-character field uniquely identifies the far end of each announcement, tone, trunk group, test trunk, national milliwatt test lines, and service circuit. Recommended subfields: PLACE, PROV, BLDG, TRAFUNIT, and SUFX.
	PLACE	character	Place. This four-character code identifies the name of the city or town at the far end of each group.
	PROV	character	Province or state. This two-character code identifies the province or state at the far end of the trunk group.
	BLDG	character	Building. This two-character code identifies the building number at the far end of the trunk group.
	TRAFUNIT	character	Traffic unit. This three-character code identifies the destination of the traffic unit at the far end of the trunk group.
	SUFY	character	Suffix. This one-character code uniquely identifies trunk groups that terminate at the same CLLI location.
ADNUM		numeric	Administrative trunk group number. Enter a number from 0 through a number that is one less than the size of table CLLI shown in table DATASIZE. The value must be unique.
TRKGRPSIZ		character	Trunk group size. This four-character field is equal to the maximum quantity of trunk members expected to be assigned to the trunk group.
<p>Note 1: Memory is allocated by the SIZE field in table DATASIZE for the entry with field DATSKEY equal to CLLI.</p> <p>Note 2: The maximum number of CLLI codes is 8192.</p>			

Basic call processing (continued)

Datafilling table CLLI for basic call processing (Sheet 2 of 2)

Field	Subfield or refinement	Entry	Explanation and action
ADMININF		see subfields	Administrative information. This 32-character field is used by the operating company to record administrative information. The information in this field is not used by the switching unit. Recommended subfields: TRAFCLS, OFFCLS, and TRKGR TYP.
	TRAFCLS	character	Trunk group traffic class. This field is optional and is for administrative purposes only.
	OFFCLS	character	Office class. This field is optional and is for administrative purposes only.
	TRKGR TYP	character	Trunk group type. This field is optional and is for administrative purposes only.

Note 1: Memory is allocated by the SIZE field in table DATASIZE for the entry with field DATSKEY equal to CLLI.

Note 2: The maximum number of CLLI codes is 8192.

Datafill example for table CLLI

The following example shows sample datafill for table CLLI.

MAP display example for table CLLI

Table: CLLI			
CLLI	ADNUM	TRKGRPSIZ	ADMININF
SYNCH	23	10	SYNCH/NONSYNCH
OFFHKSUP	45	10	SUPERVISION_SIGNAL_OFFHOOK
ALMSC	58	240	ALARM_SC
RMMVER90	79	10	ALARM_SD
LTU	177	10	LINE_TEST_UNIT

Datafilling table SITE

Table SITE contains data for the switching unit and for all remote locations connected to it. Before a line equipment number (LEN) can be assigned and before a PM can be datafilled, table SITE must be datafilled to allow the DMS system to recognize the equipment.

Basic call processing (continued)

The first entry in table SITE must be HOST for the host switching unit. Site names for remote locations are defined by the operating company.

Note: To use site names for a remote location, ensure that table OFCOPT (USINGSITE) and table OFCENG (UNIQUE_BY_SITE_NUMBERING) are correctly datafilled with both parameters set to Y.

The following table shows the datafill specific to Basic call processing for table SITE. Only those fields that apply directly to Basic call processing are shown. For a description of the other fields, refer to the *Translations Guide*.

Datafilling table SITE for basic call processing

Field	Subfield or refinement	Entry	Explanation and action
SITE		alphanumeric (4 characters maximum)	Site name. Enter the site name assigned to the remote switching unit. The first character must be alphabetic. PM type names cannot be used for site names. Note that the first entry in this field is for the host switching unit.
LTDSN		00 through 99	LEN test desk site number. Enter a unique two-digit number required to dial the site that appears under field NAME.
MODCOUNT		0	Module count. Enter 0.
OPVRCLLI		alphanumeric	Operator verification CLLI. Enter the CLLI assigned to the operator verification trunk group at the remote location.
ALMDATA		see subfields	Alarm data. This field is for remote locations only. Subfields: TYPE, TYPENO, CKTNO, POINT, and CONTMARK.
Note: Memory is automatically allocated for a maximum of 32 sites.			

Datafill example for table SITE

The following example shows sample datafill for table SITE.

Basic call processing (continued)**MAP display example for table SITE**

Table: SITE

NAME	LTDSN	MODCOUNT	OPVRCLLI	ALM	TM	TM	TM	POINT	CONTRMARK
HOST	00	0	VER90						\$
DRSC	02	2	RMMVER90	CR	RSM	0	4	0	+
				MJ	RSM	0	4	1	+
				MN	RSM	0	4	2	\$

Datafilling table PMLOADS

Table PMLOADS stores the device location of every PM loadfile which allows the XPM automatic loading feature to locate load files without user intervention.

Table PMLOADS lists active and a backup loadfiles. The active loadfile is always the default load used with the LOADPDM command and most system activities. The backup loadfile is used if there is a problem in loading or returning to service the active loadfile. The backup loadfile is always the unpatched loadfile Northern Telecom provides. Active and backup loadfiles are used when applying and removing patches.

Table PMLOADS stores data for

- the active loadfile name, which is the default load used with the LOADPDM command and most system-initiated activities
- the backup loadfile name, which is the load used if problem occurs in loading or returning to service the active loadfile. The backup loadfile is always the unpatched loadfile shipped with the SMS.
- the file locations
- the update active loadfile field, which indicates if the site wants the active fileid updated automatically. The feature allows the patched loadfile to be loaded into the XPM if a reload becomes necessary, which simplifies reload and recovery of the XPM. Active file information is updated through loadfile patching, if loadfile patching is enabled.

Basic call processing (continued)

Active and backup files are used by the system as part of loading and recovery. XPM load files must be datafilled in table PMLOADS before they can be datafilled in table LTCINV. Table LTCINV enforces this rule.

Note: An exception to this rule occurs during initial datafill, and during dump and restore. During these times, tuples in table PMLOADS are automatically datafilled when LTCINV tuples are datafilled.

Prepatched XPM loads

Prepatched XPM loads background

Prepatched XPM loads (PPXLs) are XPM loadfiles with corrective patches built into the loadfile. PPXLs are incremental loads built using patch updates. The patch updates were originally used to create patch files which have been released to the field. Therefore, no functional or technical difference exists between a regular XPM load with patches and a PPXL where the patches have been incorporated into the load. PPXLs are analogous to CM loads with patches built in based on date of shipment.

Implementation of PPXLs

At the beginning of each PPXL loadfile, there resides a 1K data block containing the patch IDs for the patches included in the PPXL. Even though the patches are built into the PPXL, corresponding patch files for each patchid listed in the 1K data block must be present when the PPXL is datafilled in table PMLOADS.

When the PPXL is datafilled in table PMLOADS, the loadset is either modified if one already exists for the base load, or the loadset is initially created if the base load is new to the DMS-100 switch.

Note: Loadsets are used to group all peripheral units loaded with the same load together. To view all loadsets on the DMS-100 switch, access the PATCHER CI level and enter the command INFORM PMALL.

After the PPXL has been added to table PMLOADS, it can be loaded either manually or automatically by the system recovery controller (SRC). After the PPXL is loaded, by either method, the patching performed after loading the PPXL is either reduced or eliminated entirely, because most or all of the patches have already been included in the load.

Once the PPXL is loaded, it can have additional patches applied to it or removed from it exactly in the same fashion as a regular XPM load can. Also, patches built into the PPXL can be removed, as long as their corresponding patch files are present.

Basic call processing (continued)

Patches added or removed following loading of a PPXL are automatically applied or removed upon subsequent reloads of the PPXL.

PPXL Naming Convention

PPXL file names have *<date>* appended to the end of their corresponding base load name. For example, a PPXL load file created for base load ESA06AS would be named ESA06AS_951023. However, the base load name always remains the same. Base loads can be identified as any load not having the *<date>* suffix.

The inherent value becomes the preservation of the patch stream with the ability to upissue a PPXL as required. A PPXL's vintage can always be identified using the date identifier.

PPXL storage requirements

When preparing to load PPXLs, Telcos are advised to double their XPM load storage requirements to accommodate the PPXLs. PPXLs require that the PPXL loadfile be stored on the ACTVOL device and the base load file be stored on the BKPVOL device.

Loading a PPXL

There are two methods of adding PPXLs to an office. The first is for upgrading an office to a new base load lineup, that is, when the base loadname is not currently in table PMLOADS. The second method is for adding PPXLs to offices that already have the base loadname in table PMLOADS. For example, CRI06AZ (the existing loadname) is appended to CRI06AZ_951023 (the PPXL added to the baseload).

Note 1: PPXLs are only supported on BCS36 or higher CM loads.

Note 2: PATCH JCK19 must be applied to the CM before continuing.

To load a PPXL in an office where the baseload is new to the office, use the following procedure.

Upgrading the base load

At the Map terminal

- 1 Copy the base loadfile and the PPXL loadfiles to disk volumes to be used for PM loads.
Note: Both the base load and the PPXL load should be copied to two disk volumes for redundancy.
- 2 Copy patches associated with the PPXL loads to the same disk volume used in step 1. A list of patches associated with each PPXL load is included in the

Basic call processing (continued)

load tape shipment. After the PPXL file is present on disk, obtain a list of patches included in the PPXL by entering

```
>XPMLFP
```

```
>PATCHLIST FILE ppxl_filename
```

where

ppxl_filename

is the filename of the PPXL loaded added to the base load

- 3 Add a new tuple for the base load to table PMLOADS. Enter the base load for the LOADNAME, the base load name for the ACTFILE and the base load name again for the BKPFIL.
- 4 Add the base loadname to the appropriate inventory table, for example LTCINV.
- 5 Edit the tuple added in step 3 to change the ACTFILE field from the base loadfile name to the PPXL filename. See the datafill example for table PMLOADS to see what this tuple looks like.
- 6 Set the loadset against both units of the XPM by entering

```
>PATCHER
```

```
>SET loadname PM pm_type device_no unit_no
```

where

loadname

is the name of the loadfile

pm_type

is the type of PM requiring the loadset

device_no

is the device number with a range of 0—255

unit_no

is the unit number, 0 or 1

- 7 Load the PPXL into each unit of the XPM by entering

```
>BSY UNIT unit_no
```

```
>LOADPM UNIT unit_no
```

```
>RTS UNIT unit_no
```

where

unit_no

is the unit number of the XPM to be loaded

- 8 Perform a SWACT of the XPM and repeat step 7.

Note 1: Once loaded, the XPM can have additional patches applied or removed in the same manner used with XPM loads in the past. Also, any patches built into the PPXL can be removed from the load as long as the actual patch file is present on disk.

Note 2: Patches added or removed following loading of a PPXL are automatically applied or removed upon subsequent reloads of the PPXL.

Basic call processing (continued)

Note 3: Non-PPXL patches are not removed when the PPXL is reloaded since there is no need to remove them because the removed patches are already out of the loadset.

To add PPXLs to an existing XPM load lineup, use the following procedure:

Adding PPXLs to an existing PM load lineup

At the MAP terminal

- 1 Verify all patch_ids associated with the PPXL are on the disk volume identified in table PMLOADS, field ACTVOL. If not present, copy the patches from tape to the correct volume. A list of patches in each PPXL is included with the PM tape shipment. Once the PPXLs are copied to disk, list the patches in the PPXL by entering

```
>XPMLFP
```

```
>PATCHLIST FILE ppxl_filename
```

where

ppxl_filename

is the filename of the PPXL loaded to disk

- 2 Copy the PPXL file (filename_date) to the disk volume used in step 1.
- 3 Copy the baseload to the disk volume identified in table PMLOADS, field BKPVOL.
- 4 Modify table PMLOADS as follows: If the XPM base loadname does not exist in table PMLOADS, add a new tuple using the previous "Upgrading baseload lineup" procedure. Otherwise, change field ACTFILE to the PPXL filename (filename_date). The loadset is either upgraded if one currently exists or created if one does not.

- 5 Set the loadset against both units of the XPM by entering

```
>PATCHER
```

```
>SET loadname PM pm_type device_no unit_no
```

where

loadname

is the name of the loadfile

pm_type

is the type of PM requiring the loadset

device_no

is the device number with a range of 0—255

unit_no

is the unit number, 0 or 1

- 6 Each unit of the XPM can be loaded with the PPXL by entering

```
>BSY UNIT unit_no
```

```
>LOADPM UNIT unit_no
```

```
>RTS UNIT unit_no
```

where

Basic call processing (continued)**unit_no**

is the unit number of the XPM to be loaded

- 7 Perform a SWACT of the XPM and repeat step 6.

Note 1: Once loaded, the XPM can have additional patches applied or removed in the same manner used with XPM loads in the past. Patches built into the PPXL can be removed from the load if the actual patch file is on disk.

Note 2: Patches added or removed following loading of a PPXL are automatically applied or removed during subsequent reloads of the PPXL.

The following table shows the datafill specific to Basic call processing for table PMLOADS. Only those fields that apply directly to Basic call processing are shown.

Datafilling table PMLOADS

Field	Subfield or refinement	Entry	Explanation and action
LOADNAME		alphanumeric (up to 8 characters)	Peripheral module load name. Enter the XPM load file name.
ACTFILE		alphanumeric (up to 32 characters)	Active load file name. The name of the active XPM loadfile (original or patched loadfile (PPXL)).
ACTVOL		alphanumeric (up to 16 characters)	Active volume. Identifies the device where the active loadfile is stored. Range: the set of disk drive unit (DDU) volumes and system load module (SLM) disks available to the CM (S00DXPM).
BKPFIL		alphanumeric (up to 32 characters)	Backup load file name. Identifies backup XPM loadfile name. It should be the same name as field LOADNAME.
BKPVOL		alphanumeric (up to 16 characters)	Backup volume. The device where the backup loadfile is stored. Range: the set of DDU volumes and SLM disks available to the CM (S00DXPM).
UPDACT		alphanumeric	Update active filename. Currently not used. Default value: N

Datafill example for table PMLOADS

The following example shows sample datafill for table PMLOADS.

Basic call processing (continued)

MAP display example for table PMLOADS

LOADNAME	ACTFILE	ACTVOL	BKPFIL	BKPVOL	UPDACT
CRI06AZ					
CRI06AZ		S00DXPM			
CRI06AZ		S00DXPM			Y

Datafilling table PMNODES

Table Peripheral module nodes (PMNODES) is read only, used by the CM to control XPM unit node tables. Table PMNODES is automatically datafilled when entries are added or changed in inventory tables. An entry will exist in table PMNODES for all subtending nodes of each XPM. Fields will be updated to reflect CM control of configuration data tables (CDT) in the XPM nodes. As nodes are deleted holes may appear in the table. These can not always be filled when a new node is added. Tuples in table PMNODES are managed so that all subtending nodes must have a higher index than their head node.

Datafilling table PMNODES for RSC-S basic operation (Sheet 1 of 3)

Field	Subfield or refinement	Entry	Explanation and action
TABKEY		0 to 4095 0 to 117	Table key. Two-part key, separated by a space, identifying the XPM where the unit node table is. The first part is host external node number. The second part is internal index number. Examples: The first key of an LTC with an external node number of 25 would be 25 1. The key of the first XPM attached to the LTC would be 25 2.
EXTNDNUM		0 to 4095	External node number. External number assigned by CM to the XPM identified in field TABKEY. Example: If the first XPM in the example above was an RCC2 with an external node of 33 the key of 25 2 would reference XPM external node 33 in the LTC node tuple. The RCC2 would also have a node tuple key of 33 1 to represent that node.
NODETYPE		see list	Node type of XPM. Generic type of PM node. Examples: LTC_NODE, RCC_NODE, LCM_NODE, and RCS_NODE.

Basic call processing (continued)**Datafilling table PMNODES for RSC-S basic operation (Sheet 2 of 3)**

Field	Subfield or refinement	Entry	Explanation and action
PMTYPE		see list	PM type. Specific node PM type. Examples: RCC2, LCME, SMSR, and LTC.
LEVEL		0 to 15	PM level. The number of device levels the XPM node is separated from the messaging host. Begins at level 0 for messaging (head) XPMs. Examples: An LCME at level 2, attached to the RCC2 at level 1, which is attached to the HOST LTC at level 0. The same LCME would be at level 1 of the RCC2 tuple at level 0.
MSGHOST		0 to 4095	Messaging host. External node responsible for transferring messages to this node. A messaging host must be capable of transferring messages. Examples: LTC and RCC. Examples of XPMs not capable of being a messaging host are: RCU and SMSR.
PHYSHOST		0 to 4095	Physical host. External node to which this XPM node is physically attached. Example: The LCME is physically attached to RCC2 at external node 33.
PORTS		0 to 127	Number of ports. Total number of P-side ports in the physical host required by this XPM node.
STPORT		0 to 255	Starting port. First P-side port in the physical host used by this XPM node.
TERMS		0 to 4095	Number of terminals. Total number of terminals in the physical host required by this XPM node.
STTERM		0 to 8675	Starting terminal. First terminal in the physical HOST used by this XPM node.
PROTOCOL		alphanumeric	Message protocol. Type of message protocol used by the physical host to node links. Examples: MDS30, MDMSX, MHDLC
MS		M or S	Master or slave. M if this node contains the master clock.
IPML		Y or N	Inter-peripheral message link (IPML). Y if this node is configured as part of an IPML.

Basic call processing (continued)**Datafilling table PMNODES for RSC-S basic operation (Sheet 3 of 3)**

Field	Subfield or refinement	Entry	Explanation and action
MODE		T or P	Table entry mode. Entries in table are made by terminal (T) or port (P) indexing.
SLLCON		Y or N	Site line load control. Y if this node is at a site using Essential Line Service Protection (ESP) or other site line load control features.
NT6X28		N	Uses NT6X28 card. Y if this XPM uses the NT6X28 card. The NT6X28 signaling interface card is used on the International Digital Trunk Controller (IDTC). Always enter N.
LCMLGMEM		Y or N	LCM large memory. Y if this XPM is an LCM with large memory (256k bytes).
RSVPORTS		Y or N	Reserved ports. Y if this XPM has ports that are reserved for messaging.
RSVTERMS		Y or N	Reserved terminals. Y if this XPM has terminals that are reserved for messaging.
MATENODE		Y or N	Mate node. Y if this node is part of a dual configuration.
PACKED		Y or N	Packed internal tables. Y if internal node tables are packed on this node. Prior to this feature the node table was compressed when the XPM was RTS with the NODATASYNC option. Compression will now only happen when both units of an XPM are taken out-of-service (OOS) and loaded by the CM.
SUPPCDT		Y Y	Support configuration data table (CDT). Y for each unit if CDT management is supported.
CMINCTRL		Y or N	CM node control. Y if the node is under CM control.

Datafill example for table PMNODES

The following examples show datafill for an LTC node with an RCC2 node connected and an LCME connected to the RCC2.

Basic call processing (continued)**MAP display example for table PMNODES (LTC tuple)**

Table: PMNODES

TABKEY	EXTNDNUM	NODETYPE	PMTYPE	LEVEL	MSGHOST	PHYSHOST	PORTS			
25	1	25	LTC_NODE	LTC	0	25	16			
STPORT	TERMS	STTERM	PROTOCOL	MS	IPML	MODE	SLLCON	NT6X28	LCMLGMEM	RSVPORTS
0	641	1	MDS30A	S	N	P	N	N	N	Y
RSVTERMS	MATENODE	PACKED	SUPPCDT	CMINCTRL						
Y	N	Y	YY	Y						

MAP display example for table PMNODES (LTC to RCC2 tuple)

Table: PMNODES

TABKEY	EXTNDNUM	NODETYPE	PMTYPE	LEVEL	MSGHOST	PHYSHOST	PORTS			
25	2	33	RCC_NODE	RCC2	0	25	16			
STPORT	TERMS	STTERM	PROTOCOL	MS	IPML	MODE	SLLCON	NT6X28	LCMLGMEM	RSVPORTS
16	641	642	MDMSX	M	N	P	N	N	N	Y
RSVTERMS	MATENODE	PACKED	SUPPCDT	CMINCTRL						
Y	N	Y	YY	Y						

MAP display example for table PMNODES (LTC to RCC2 to LCME tuple)

Table: PMNODES

TABKEY	EXTNDNUM	NODETYPE	PMTYPE	LEVEL	MSGHOST	PHYSHOST	PORTS			
25	3	74	LCM_NODE	LCME	2	33	18			
STPORT	TERMS	STTERM	PROTOCOL	MS	IPML	MODE	SLLCON	NT6X28	LCMLGMEM	RSVPORTS
0	641	1	MDMSX	S	N	P	N	N	Y	N
RSVTERMS	MATENODE	PACKED	SUPPCDT	CMINCTRL						
N	N	Y	YY	Y						

Basic call processing (continued)

MAP display example for table PMNODES (RCC2 tuple)

```

Table: PMNODES

  TABKEY  EXTNDNUM  NODETYPE  PMTYPE  LEVEL  MSGHOST  PHYSHOST  PORTS
    33     1         33   RCC_NODE  RCC2    0         33         33     16

STPORT  TERMS  STTERM  PROTOCOL  MS  IPML  MODE  SLLCON  NT6X28  LCMLGMEM  RSVPORTS
   0     641    1     MDMSX   S    N    P     N       N         N         Y

RSVTERMS  MATENODE  PACKED  SUPPCDT  CMINCTRL
          Y       N       Y       YY       Y
    
```

MAP display example for table PMNODES (RCC2 to LCME tuple)

```

Table: PMNODES

  TABKEY  EXTNDNUM  NODETYPE  PMTYPE  LEVEL  MSGHOST  PHYSHOST  PORTS
    33     2         74   LCM_NODE  LCME    1         33         33     18

STPORT  TERMS  STTERM  PROTOCOL  MS  IPML  MODE  SLLCON  NT6X28  LCMLGMEM  RSVPORTS
  18     641   642     MDMSX   S    N    P     N       N         Y         N

RSVTERMS  MATENODE  PACKED  SUPPCDT  CMINCTRL
          N       N       Y       YY       Y
    
```

Note: Each XPM node in the link that is capable of messaging would have a tuple in table PMNODES to address the LCME.

Datafilling table LTCINV

Table Line Trunk Controller Inventory (LTCINV) contains inventory data, except P-side link assignments, for PM types LTC, digital trunk controller (DTC), LGC, subscriber module rural (SMR), subscriber module SLC-96 (SMS), subscriber module urban (SMU), and international digital trunk controller (IDTC). With RSC-S, this table defines the LTC/LGC on the C-side of the RCC2.

Basic call processing (continued)

The following table shows the datafill specific to Basic call processing for table LTCINV. Only those fields that apply directly to Basic call processing are shown. For a description of the other fields, refer to the *Translations Guide*.

Datafilling table LTCINV for basic call processing (Sheet 1 of 3)

Field	Subfield or refinement	Entry	Explanation and action
LTCNAME		see subfields	Link trunk controller name. Subfields: XPMTYPE and XPMNO.
	XPMTYPE	see list	XPM type. Enter LTC to support trunking. Enter LGC if lines only are to be supported. Entry values: LTC, DTC, LGC, SMR, SMS, SMU, IDTC, ILGC, ILTC, PDTTC, BDTC, TRCC, PLGC, DTCI, TMS, SMA, and DFI.
	XPMNO	0 through 255	XPM number. Enter the XPM number. Range: 0—127 for NT40, 0—255 for SuperNode.
FRTYPE		LTE or LGE	Frame type. Enter LTE for LTC, LGE for LGC.
			Enter the location of the C-side PM in fields FRNO, SHPOS, FLOOR, ROW, and FRPOS.
EQPEC		alphanumeric	Product equipment code. Enter 6X02AG/AH for the LTC.
LOAD		alphanumeric	Load. Enter the load the PM is to use. It should display a load listed table PMLOADS.
EXECTAB		see subfields	Executive table. Subfields: TRMTYPE, EXEC, and CONTMARK. The terminal type and its associated execs are datafilled together.
			Note: Changes to fields with multiple entries should be made in the PROMPT mode only.
	TRMTYPE	see list	Terminal type. Enter the type of terminal models to be used: POTS (regular lines), KSET (EBS terminals), ABTRK (regular trunks), RMM_TERM (MTC trunks).
	EXEC	see subfields	Executive programs. Enter the execs associated with the terminal type.

Basic call processing (continued)

Datafilling table LTCINV for basic call processing (Sheet 2 of 3)

Field	Subfield or refinement	Entry	Explanation and action
CSLNKTAB		see subfields	C-side link table. Subfields: NMNO, NMPORT, and CONTMARK. Note: Changes to fields with multiple entries should be made in the PROMPT mode only.
	NMPAIR	0 through 31	Network module pair number. Enter the network link where the PM is assigned, corresponding to C-side links 0—15 of the PM.
	NMPORT	0 through 63	Network module port. Enter the network port corresponding to the above link.
	CONTMARK	+ or \$	Continuation mark. Where the record is other than the last for a specific scan point, enter a plus sign (+), which indicates additional data for the scan point is specified in the next record. Where the record is the last for a specific scan point, enter \$.
OPTCARD		see list	Optional card. This field is a vector with up to ten entries. Enter this when the LTC includes the UTR, TONE, and message card. If the CMR card is included, enter the CMRLOAD. New values include CMR5, UTR6, and UTR7. Note: Changes to fields with multiple entries should be made in the PROMPT mode only. In nonprompt mode it is possible to leave out existing entries
NT7X05AA		NT7X05AA	If NT7X05AA is entered, the system prompts for the slot_number. Slot numbers for the NT7X05AA in RCC2 are 5 and 23, or 7 and 21. Note 1: To support NT7X05 PRL functionality, MX77AA MX77AA is required in field PECS6X45. AX74AA AX74AA does not support NT7X05 PRL functionality. Note 2: If the CMR card is also provisioned, use slot numbers 7 and 21. (Slots 5 and 23 are dedicated to the CMR card.) If the CMR card is not provisioned, use either slots 5 and 23 or 7 and 21.

Basic call processing (continued)**Datafilling table LTCINV for basic call processing (Sheet 3 of 3)**

Field	Subfield or refinement	Entry	Explanation and action
TOSET		see list	Tone set. Enter the name of the tone set for the switch being datafilled. For example, NORTHAM or NORTHAA for the ADSI-compliant tone set card (NT6X69AD).
PECS6X45		see list	6X45 equipment PECS. One PEC is required for each LTC unit. Enter the PEC for unit 0 first. The PEC must reflect the minimum firmware capabilities in the processor complex of each unit. For the LTC PLUS, MX77 is added. Note: When the NT7X05 PRL is datafilled as an optional card, enter MX77AA MX77AA. AX74AA AX74AA is not allowed as a valid value when the NT7X05 PRL is datafilled as an optional card because the NTAX74 CAP does not support NT7X05 PRL functionality.
E2LOAD		alphanumeric	EEPROM file. Contains the name of the loadfile in the NTMX77AA EEPROM.
OPTATTR			Optional attribute. Since this is not a DTC for CCS7, leave blank. Subfield: CONTMARK.
	CONTMARK	+ or \$	Continuation mark. Where the record is other than the last for a specific scan point, enter a plus sign (+), which indicates additional data for the scan point is specified in the next record. Where the record is the last for a specific scan point, enter \$.
PEC6X40		alphanumeric	6X40 equipment PEC. Enter the version of the NT6X40 to be used.

Datafill example for table LTCINV

The following examples show sample datafills for table LTCINV for both an RCC2 provisioned with the NTMX77AA UP and an RCC2 provisioned with the optional NTAX74AA CAP, respectively.

Basic call processing (continued)

MAP display example for table LTCINV

```

Table: LTCINV

LTCNAME   FRTYPE  FRNO  SHPOS  FLOOR  ROW  FRPOS  EQPEC  LOAD
-----
LTC 1     LGE     1    18     0      C    6      6X02AG ECL08xx

EXECTAB
CONTMARK

(POTS POTSEX) (KEYSET KSETEX) (RMM_TERM RSMEX) (ABTRK DTCEX) $

CSLNKTAB

(9 17) (13 61) (5 14) (0 29) (1 30) (2 31) (3 28) (4 29) $

OPTCARD                                CMRLOAD
-----
(UTR6) (ISP16) (MSG6X69) (NT7X05AA 7) (CMR18 CMRAG03) $

TONESET  PECS6X45  E2LOAD  OPATTR  PEC6X40
-----
NORTHAM  MX77AA  MX77AA  MX77xxxx  $  6X40AC
    
```

Note 1: xx in field LOAD and xxxx in field E2LOAD represent alphanumeric entries, for example B1 and XE01, respectively.

Note 2: If the shelf is equipped with a processor different from NTMX77, field E2LOAD is automatically datafilled with the value of NILLOAD.

Note 3: NTMX77 UP is required to support NT7X05 functionality. The optional NTAX74 CAP does not support NT7X05 PRL functionality. When a user attempts to datafill field PECS6X45 with AX74AA AX74AA instead of MX77AA MX77AA when NT7X05 is already datafilled as an optional card, the tuple change is disallowed and the MAP displays the following message:

Info: NT7X05AA requires MX77 processor

Note 4: When field PECS6X45 is datafilled with AX74AA AX74AA instead of MX77AA MX77AA, the load name prefix in field LOAD changes from ECL to XLI. For example, ECL08xx (for MX77) changes to XLI08XX (for AX74AA). The following example shows sample datafill for table LTCINV when the RCC2 is datafilled for the NTAX74AA CAP.

Basic call processing (continued)**MAP display example for table LTCINV datafilled for NTAX74AA CAP**

```

Table: LTCINV
LTCNAME   FRTYPE  FRNO  SHPOS  FLOOR  ROW  FRPOS  EQPEC  LOAD
-----
LTC 1     LGE     1     18     0      C   6     6X02AG XLI08xxx
EXECTAB
CONTMARK
(POTS POTSEX) (KEYSET KSETEX) (RMM_TERM RSMEX) (ABTRK DTCEX) $
CSLNKTAB
(9 17) (13 61) (5 14) (0 29) (1 30) (2 31) (3 28) (4 29) $
OPTCARD                                CMRLOAD
(UTR6) (ISP16)                        (MSG6X69) (CMR18 CMRAG03) $
TONESET  PECS6X45  E2LOAD  OPATTR  PEC6X40
NORTHAM  AX74AA  AX74AA  AX74xxx  $      6X40AC

```

Datafilling table CARRMTC

Table CARRMTC allows the DMS switch administration to datafill maintenance control information on peripherals, OOS limits for alarms, and system RTS occurrences. For table CARRMTC, fields CSPMTYPE and SELECTOR (subfield of ATTR) have been expanded to include new PM type RCC2.

A carrier maintains communication on links connecting DMS peripherals to channel banks, DMS peripherals to remote DMS peripherals, or remote-to-remote DMS peripherals. Up to 16 entries exist for each type of peripheral that is capable of providing carrier links in the switch.

CPM carrier tuples contain various carrier maintenance limits and information for DS-1 carriers. It is recommended that, like XPM carriers, one tuple be added to provide the maintenance thresholds for CPM carriers. During initial program load (IPL), one default tuple is datafilled in table CARRMTC for each XPM type existing in the office and in field CSPMTYPE. Other tuples are added manually for different maintenance thresholds.

Basic call processing (continued)

A tuple in table CARRMTC must be datafilled before the XPM's P-side inventory table tuple (in table RCCPSINV) is changed. Before a tuple in table CARRMTC is deleted or changed, no links in table RCCPSINV can reference field TMPLNM in table CARRMTC.

The choice of entries for each carrier is datafilled in the inventory table of the C-side peripheral, table LTCPSINV. The following checks are made between table CARRMTC and table LTCPSINV:

- When a carrier index (CARRIDX) is datafilled in table LTCPSINV, an entry for the PM type (in this case RCC2 and LTC) must already be present in table CARRMTC.
- When an entry is deleted from table CARRMTC, the entry cannot be referenced by any carriers in table LTCPSINV. Otherwise, the deletion command is rejected.
- When an existing entry in table CARRMTC is changed, table LTCPSINV is checked to determine if the entry is referenced by in-service carriers. If so, the change command is rejected and a list of the in-service carriers is displayed on the MAP screen.

The following procedure shows the datafill for table CARRMTC. This procedure contains only those fields that apply to basic call processing. Refer to the *Translations Guide* for a description of the other fields.

Datafilling table CARRMTC for basic call processing (Sheet 1 of 4)

Field	Subfield or refinement	Entry	Explanation and action
CSPMTYPE		RCC2	C-side node PM type. Enter the PM type of the node on the C-side of the carrier link; in this case, RCC2.
TMPLTNM		character	Template name. Enter the template name (up to 16 characters) for the PM. This entry also appears in field CARRIDX of table LTCPSINV. The default value is DEFAULT.
<p>Note 1: The DMS system adds the first tuple for RCC2 to table CARRMTC automatically during IPL or first restart after IPL. The entry is designated as index 0 and has the value DEFAULT in field TMPLTNM and default values for the other fields. This tuple cannot be deleted, and only fields ES, SES, and thresholds for frame and slip losses can be changed.</p> <p>Note 2: Tuples other than the default tuple must be added manually before they can be referenced in table LTCPSINV. These tuples can be deleted only if no DS-1 carriers are associated with them.</p> <p>Note 3: Tuples can be changed in table CARRMTC only if the associated DS-1 carriers are manually busied (ManB) or offline (OFFL).</p>			

Basic call processing (continued)

Datafilling table CARRMTC for basic call processing (Sheet 2 of 4)

Field	Subfield or refinement	Entry	Explanation and action
RTSML		0-255	Return-to-service maintenance limit. Enter the number of times, within the audit interval, a carrier may be returned to service by the system before a warning is issued. Value 255 disables this feature.
RTSOL		0-255	Return-to-service OOS limit. Enter the number of times, within the audit interval, a carrier may be returned to service by the system before it is placed permanently out of service. Value 255 disables this feature.
ATTR		see subfield	Attribute. This field contains subfield SELECTOR.
	SELECTOR	RCC2	Selector. Enter carrier type RCC2.
CARD		alphanumeric	Card. Enter the PEC of the DS-1 interface card used. Range of values for the RCC2 is MX81AA (clear channel). Refinement attribute fields are the same for MX81AA as those for NT6X50AB.
VOICELAW		character	Voice law. Enter the voice law used in the carrier. A_LAW is used mainly in international switches; MU_LAW is used mainly in North American switches.
FF		SF	Frame format. Enter SF (standard frame or super frame) in this field.
ZLG		ZCS	Zero logic. Enter ZCS (Zero Code Suppression) in field ZLG. If all zeros are transmitted, a 1 is inserted in the second least significant bit position.
<p>Note 1: The DMS system adds the first tuple for RCC2 to table CARRMTC automatically during IPL or first restart after IPL. The entry is designated as index 0 and has the value DEFAULT in field TEMPLTNM and default values for the other fields. This tuple cannot be deleted, and only fields ES, SES, and thresholds for frame and slip losses can be changed.</p> <p>Note 2: Tuples other than the default tuple must be added manually before they can be referenced in table LTCPSINV. These tuples can be deleted only if no DS-1 carriers are associated with them.</p> <p>Note 3: Tuples can be changed in table CARRMTC only if the associated DS-1 carriers are manually busied (ManB) or offline (OFFL).</p>			

Basic call processing (continued)

Datafilling table CARRMTC for basic call processing (Sheet 3 of 4)

Field	Subfield or refinement	Entry	Explanation and action
BERB		BPV	Bit error rate base. Enter BPV for bipolar violation.
DLK		NILDL	Data link. Currently, only NILDL is supported.
IAT		Y	Inhibit alarm transmit. Enter Y for field IAT to inhibit yellow alarms.
LCGAST		numeric	Local carrier group alarm set threshold. Enter value for the threshold in units of 10 ms.
LCGACL		numeric	Local carrier group alarm clear threshold. Enter value for the threshold in units of 10 ms.
RCGAST		1-9999	Remote carrier group alarm set threshold. Enter value for the threshold in units of 10 ms.
RCGACL		1-9999	Remote carrier group alarm clear threshold. Enter value for the threshold in units of 10 ms.
AISST		1-9999	Alarm indication signal set threshold. Enter value for the threshold in units of 10 ms.
AISCL		1-9999	Alarm indication signal clear threshold. Enter value for the threshold in units of 10 ms.
BEROL		3-6	Bit error rate OOS limit. Enter the bit error rate OOS limit expressed as the negative of the exponent of 10 (10E-n). Three, for example, represents 1 in 1000 bit error rate.
BERML		4-7	Bit error rate maintenance limit. Enter the bit error rate maintenance limit expressed as the negative of the exponent of 10 (10E-n).
<p>Note 1: The DMS system adds the first tuple for RCC2 to table CARRMTC automatically during IPL or first restart after IPL. The entry is designated as index 0 and has the value DEFAULT in field TMPLTNM and default values for the other fields. This tuple cannot be deleted, and only fields ES, SES, and thresholds for frame and slip losses can be changed.</p> <p>Note 2: Tuples other than the default tuple must be added manually before they can be referenced in table LTCPSINV. These tuples can be deleted only if no DS-1 carriers are associated with them.</p> <p>Note 3: Tuples can be changed in table CARRMTC only if the associated DS-1 carriers are manually busied (ManB) or offline (OFFL).</p>			

Basic call processing (continued)**Datafilling table CARRMTC for basic call processing (Sheet 4 of 4)**

Field	Subfield or refinement	Entry	Explanation and action
ES		0-9999	Error second threshold. Enter value for the threshold in units of 10 ms.
SES		0-9999	Severe error second threshold. Enter value for the threshold in units of 10 ms.
FRAMEML		0-9999	Frame maintenance limit. Enter the maintenance limit for frame loss.
FRAMEOL		0-9999	Frame loss limit. Enter the OOS limit for frame loss. Note: FRAMEOL should be larger than FRAMEML.
SLIPML		0-9999	SLIP maintenance limit. Enter the maintenance limit for slip.
SLIPOL		0-9999	SLIP OOS Limit. Enter the OOS limit for slip. Note: SLIPOL should be larger than SLIPML.
<p>Note 1: The DMS system adds the first tuple for RCC2 to table CARRMTC automatically during IPL or first restart after IPL. The entry is designated as index 0 and has the value DEFAULT in field TEMPLNM and default values for the other fields. This tuple cannot be deleted, and only fields ES, SES, and thresholds for frame and slip losses can be changed.</p> <p>Note 2: Tuples other than the default tuple must be added manually before they can be referenced in table LTCPSINV. These tuples can be deleted only if no DS-1 carriers are associated with them.</p> <p>Note 3: Tuples can be changed in table CARRMTC only if the associated DS-1 carriers are manually busied (ManB) or offline (OFFL).</p>			

Datafill example for table CARRMTC

The following example shows sample datafill for RSC-S basic call processing in table CARRMTC.

Basic call processing (continued)

MAP display example for table CARRMTC

```

Table: CARRMTC

CSPMTYPE  TEMPLTNM  RTSML  RTSOL  ATTR
-----
RCC2      DEFAULT  255   255   DS1 NTMX81AA MU_LAW SF
                ZCS BPV NILDL Y 100 300
                50 50 150 1000 3 6 864
                100 17 511 4   255
    
```

Datafilling table LTCPSINV

Table Line Trunk Controller P-side link Inventory (LTCPSINV) contains the assignment of the P-side links for host PMs. The key for table LTCPSINV is the same as table LTCINV. The memory is automatically allocated for a maximum of 128 tuples.

The following table shows the datafill specific to Basic call processing for table LTCPSINV. Only those fields that apply directly to Basic call processing are shown. Refer to the *Translations Guide* for a description of the other fields.

Datafilling table LTCPSINV for RSC-S basic call processing (Sheet 1 of 2)

Field	Subfield or refinement	Entry	Explanation and action
LTCNAME		see subfield	Link trunk controller name. Contains subfields XPMTYPE and XPMNO.
	XPMTYPE	LTC or LGC	PM type. This type must match the entry in table LTCINV, either LTC or LGC.
	XPMNO	numeric	PM number. Ranges: 0-127 for NT40, 0-255 for SuperNode.
PSLNKTAB		0-19	P-side link table. Subfields: PSLINK, PSDATA, and CONTMARK. Enter the vector number. Note: Changes to fields with multiple entries should be made in the PROMPT mode only.
	PSLINK	numeric	P-side link. Enter the P-side port number.
Note: The fields in PSDATA are datafilled depending on which value of AREASELCT is chosen. If AREASELCT is DS30A, DCH, or NILTYPE, no other fields require datafill. If PSDATA is DS-1, complete fields CARRIDX and ACTION.			

Basic call processing (continued)**Datafilling table LTCPSINV for RSC-S basic call processing (Sheet 2 of 2)**

Field	Subfield or refinement	Entry	Explanation and action
	PSDATA	DS-1 or DS30A	P-side data. Enter DS-1 for trunks and remote nodes, including RCC, RCC2, and RLCM. Enter DS30A if the P-side interface is to a local LCM.
	CONTMARK	+ or \$	Continuation mark. Where the record is other than the last for a specific scan point, enter a plus sign (+), which indicates additional data for the scan point is specified in the next record. Where the record is the last for a specific scan point, enter a dollar sign (\$).

Note: The fields in PCDATA are datafilled depending on which value of AREASELCT is chosen. If AREASELCT is DS30A, DCH, or NILTYPE, no other fields require datafill. If PCDATA is DS-1, complete fields CARRIDX and ACTION.

Datafill example for table LTCPSINV

The following example shows sample datafill for table LTCPSINV.

MAP display example for table LTCPSINV

```

Table: LTCPSINV

LTCNAME  PSLNKTAB                                CONTMARK
-----
LTC 1 (0 DS-1 DEFAULT N) (1 DS-1 DEFAULT N) (2 DS-1 DEFAULT N)+
(3 DS-1 DEFAULT N) (4 DS-1 DEFAULT N) (5 DS-1 DEFAULT N)      +
(6 DS-1 DEFAULT N) (7 NILTYPE) (8 NILTYPE) (9 NILTYPE)        +
(10 NILTYPE) (11 NILTYPE) (12 NILTYPE) (13 NILTYPE)           +
(14 NILTYPE) (15 NILTYPE) (16 NILTYPE) (17 NILTYPE)           +
(18 NILTYPE) (19 NILTYPE)                                     $

```

Datafilling table RCCINV

When changing (deleting, replacing, or adding) a C-side link, the link affected and all subsequent links must be busied before any modifications can be made in table RCCINV.

The capability to skip links is provided through the addition of the NILPORT option to field CSLNKTAB of table RCCINV. The NILPORT option allows

Basic call processing (continued)

ports to be skipped when datafilling RCC2 C-side DS-1 link. If a port is to remain unequipped, datafill NILPORT.



CAUTION

Possible loss of service

Possible degradation of service can occur when adding, deleting, or changing C-side links in table RCCINV. Modifying table RCCINV is a real-time intensive activity. This table modification should be done during periods of low traffic to prevent degradation of subscriber service.

The following procedure shows the datafill for table RCCINV. This procedure contains only those fields that apply to basic call processing. Refer to the *Translations Guide* for a description of the other fields. Field FRATYPE contains new values. A field is added that contains the name of the loadfile that is associated with the EEPROM.

Note: When changing (deleting, replacing, or adding) a C-side link, the link affected and all subsequent links must be busied before any modifications can be made in table RCCINV.

Datafilling table RCCINV for RSC-S basic call processing (Sheet 1 of 5)

Field	Subfield or refinement	Entry	Explanation and action
RCCNAME		see subfields	RCC2 name. Contains subfields SITE, PMTYPE, and RCCNO.
	SITE	character	Site. Enter the site name assigned to the remote location. This entry should also appear in table SITE.
	PMTYPE	RCC2	PM type. Enter RCC2 for the non-ISDN RCC2.
	RCCNO	numeric	RCC2 Number. This number is unique by office and not by site.
<p>Note: When datafilling field C-side link table (CSLNKTAB), assure message links are not assigned to the same physical interface card. When the interface card supports two or more links, separate the message links by the number of links on the interface cards. This applies to all interface link types; DS-1, DS30, DS30A, or PCM-30. Table control will issue a warning if an attempt is made to assign message links on the same interface card. Assigning message links to the same interface card can cause an E1 outage (failure of all message links) if the card fails.</p>			

Basic call processing (continued)**Datafilling table RCCINV for RSC-S basic call processing (Sheet 2 of 5)**

Field	Subfield or refinement	Entry	Explanation and action
FRTYPE		CRSC or CEXT	Frame type. Enter CRSC for the RCC2 shelf. Enter CEXT for the RCC2 extension shelf.
Enter the location of the RCC2 in fields FRNO, SHPOS, FLOOR, ROW, and FRPOS.			
EQPEC		alphanumeric	Equipment PEC. Enter the PEC MX85AA for the RCC2.
LOAD		alphanumeric	Load. Enter the load for the RCC2. Ensure that table PMLOADS contains this table.
EXEC		see subfields	EXEC table. Contains subfields TRMTYPE, EXEC, and CONTMARK. As with LTCINV, each terminal type is associated with its particular execs.
			Note: Changes to fields with multiple entries should be made in the PROMPT mode only.
	TRMTYPE	alphanumeric	Terminal type. Enter the type of terminal models to be used. POTS is for regular lines, KEYSET for EBS/data lines, RMM_TERM for remote MTC trunks, ABTRK for regular trunks, ESA for ESA lines, MX5X09 and M5X12 for Meridian 9- and 12- button sets.
	EXEC	character	Executive programs. Enter the execs that are associated with the terminal type. Examples are POTSEX, KSETEX, DTCEX, ESAEX, and RSMEX.
	CONTMARK	+ or \$	Continuation mark. Where the record is other than the last for a specific scan point, enter a plus sign (+), which indicates additional data for the scan point is specified in the next record. Where the record is the last for a specific scan point, enter a dollar sign (\$).
Note: When datafilling field C-side link table (CSLNKTAB), assure message links are not assigned to the same physical interface card. When the interface card supports two or more links, separate the message links by the number of links on the interface cards. This applies to all interface link types; DS-1, DS30, DS30A, or PCM-30. Table control will issue a warning if an attempt is made to assign message links on the same interface card. Assigning message links to the same interface card can cause an E1 outage (failure of all message links) if the card fails.			

Basic call processing (continued)

Datafilling table RCCINV for RSC-S basic call processing (Sheet 3 of 5)

Field	Subfield or refinement	Entry	Explanation and action
CSPM		see subfields	C-side PM. Contains subfields PMTYPE and XPMNO.
	PMTYPE	LTC or LGC	PM type. Enter the type of peripheral to which the RCC2 is attached. Note that this LTC or LGC can be part of a host ISDN configuration. DFI has been added to the entry value range.
	XPMNO	numeric	PM number. Enter the PM number to which the RCC2 C-side is attached. Ranges: 0-127 for NT40, 0-255 for SuperNode.
CSLNKTAB		numeric	C-side link table. This is a vector with up to 16 entries. Enter the LTC P-side DS-1 links (0-19) to which the RCC2 C-side is assigned. Note that all links for an RCC2 must connect to the same LTC. Message links (first and third entries) must be assigned to different shelves (units) of the frame so that corruption or power failure does not affect service. Subfield: CONTMARK. Note: Changes to fields with multiple entries should be made in the PROMPT mode only.
	CONTMARK	+ or \$	Continuation mark. Where the record is other than the last for a specific scan point, enter a plus sign (+), which indicates additional data for the scan point is specified in the next record. Where the record is the last for a specific scan point, enter a dollar sign (\$).
ESA		Y or N	Emergency stand alone. Enter Y(es) or N(o). Controls whether the RCC2 has ESA capability.
INTRASW		Y or N	Intraswitching. Controls whether intraswitching is allowed.
<p>Note: When datafilling field C-side link table (CSLNKTAB), assure message links are not assigned to the same physical interface card. When the interface card supports two or more links, separate the message links by the number of links on the interface cards. This applies to all interface link types; DS-1, DS30, DS30A, or PCM-30. Table control will issue a warning if an attempt is made to assign message links on the same interface card. Assigning message links to the same interface card can cause an E1 outage (failure of all message links) if the card fails.</p>			

Basic call processing (continued)**Datafilling table RCCINV for RSC-S basic call processing (Sheet 4 of 5)**

Field	Subfield or refinement	Entry	Explanation and action
OPTCARD		alphanumeric	<p>Optional card. This is a vector with up to 10 entries. For the RCC2, slot 4 must be used for the ISP card. Slots 6 and 7 only can be used for either the global tone receiver (GTR) or universal tone receiver (UTR) card. The CMR card can occupy slot 5 in unit 0 and slot 23 in unit 1. With the CMR card, only 10 DS-1s can be supported on the C-side and P-side.</p> <p>Note 1: Datafill for the CMR and UTR cards is required for unit 0 only.</p> <p>Note 2: The GTR and UTR must not be mixed on the same RCC2. Presently, there is no way to determine which receiver interprets the tone samples. Some call processing tones may be degraded if designed for use with a GTR, if interpreted by a UTR.</p> <p>Examples: CMR5, ISP16, UTR6, and UTR7. For an RCC2 with extended distance capability (EDC), the MSGMX76 card is required. Enter MSGMX76 REM HDLC to activate dynamic InSv upgrade from DMS-X to HDLC. Default: MSG6X69 REM DMSX. DMS-X to HDLC dynamic upgrade is not allowed in the inactive CM.</p> <p>Note: Changes to fields with multiple entries should be made in the PROMPT mode only.</p>
CMRLOAD		alphanumeric	<p>Class modem resource load. Enter the CMR loadname.</p>
<p>Note: When datafilling field C-side link table (CSLNKTAB), assure message links are not assigned to the same physical interface card. When the interface card supports two or more links, separate the message links by the number of links on the interface cards. This applies to all interface link types; DS-1, DS30, DS30A, or PCM-30. Table control will issue a warning if an attempt is made to assign message links on the same interface card. Assigning message links to the same interface card can cause an E1 outage (failure of all message links) if the card fails.</p>			

Basic call processing (continued)

Datafilling table RCCINV for RSC-S basic call processing (Sheet 5 of 5)

Field	Subfield or refinement	Entry	Explanation and action
NT7X05AA		NT7X05AA	<p>If NT7X05AA is entered, the system prompts for the slot_number. Slot numbers for the NT7X05AA in RCC2 are 5 and 23, or 7 and 21.</p> <p>Note 1: To support NT7X05 PRL functionality, MX77AA MX77AA is required in field PECS6X45. AX74AA AX74AA in field PECS6X45 does not support NT7X05 PRL functionality.</p> <p>Note 2: If the CMR card is also provisioned, use slot numbers 7 and 21. (Slots 5 and 23 are dedicated to the CMR card.) If the CMR card is not provisioned, use either slots 5 and 23 or 7 and 21.</p>
TONESET		character	<p>Tone set. Enter NORTHAM for North America. If the NT6X69AD card has been added for ADSI compliancy, enter NORTHAA. Otherwise, enter a blank for DEFAULT.</p>
PECS6X45		MX77AA, MX77AA or AX74AA, AX74AA	<p>Product engineering code. Enter the PEC of the NT6X45 card in unit 0 and 1 of the RCC2. The PEC must reflect minimum firmware capabilities in the processor complex of each unit. Value AX74AA has been added.</p> <p>Note: When the NT7X05 PRL is datafilled as an optional card, enter MX77AA MX77AA. AX74AA AX74AA is not allowed as a valid value when the NT7X05 PRL is datafilled as an optional card because the NTAX74 CAP does not support NT7X05 PRL functionality.</p>
E2LOAD		alphanumeric	<p>EEPROM file. Contains the name of the loadfile in the NTMX77AA EEPROM or the optional NTAX74AA EEPROM.</p>
<p>Note: When datafilling field C-side link table (CSLNKTAB), assure message links are not assigned to the same physical interface card. When the interface card supports two or more links, separate the message links by the number of links on the interface cards. This applies to all interface link types; DS-1, DS30, DS30A, or PCM-30. Table control will issue a warning if an attempt is made to assign message links on the same interface card. Assigning message links to the same interface card can cause an E1 outage (failure of all message links) if the card fails.</p>			

Basic call processing (continued)**Datafill example for table RCCINV**

The following examples show sample datafills for table RCCINV for both an RCC2 provisioned with the NTMX77AA UP and an RCC2 provisioned with the optional NTAX74AA CAP, respectively.

MAP display example for table RCCINV

```

Table: RCCINV

RCCNAME      FRTYPE FRNO SHPOS FLOOR ROW FRPOS  EQPEC  LOAD
-----
CARY RCC2 0
      1101 CRSC  0   5   0   C   0      MX85AA  CRI08xx

EXECTAB                      CONTMARK
-----
(POTS POTSEX) (KEYSET KSETEX) (RMM_TERM RSMEX) (ESALINES ESAEX) $

CSPM          CSLNKTAB                      CONTMARK
-----
LTC 1          (0) (1) (2) (3) (4) (5) (6) (7)          $

ESA  INTRASW  OPTCARD  CMRLOAD                      CONTMARK
-----
Y   Y   (UTR6) (NT7X05AA 7) (MSG6X69) (CMR5 CMRAG03) (ISP16)  $

TONESET  PECS6X45  E2LOAD  EXTINFO
-----
NORTHAM  MX77AA  MX77AA  MX77xxxxx  CEEXT 0 4 0 E 15 MX86AA L

```

Note 1: xx in field LOAD stands for alphanumeric text, for example B1.

Note 2: If the shelf is equipped with a processor other than NTMX77, field E2LOAD is automatically datafilled with the value of NILLOAD.

Note 3: NTMX77 UP is required to support NT7X05 functionality. The optional NTAX74 CAP does not support NT7X05 PRL functionality. When a user attempts to datafill field PECS6X45 with AX74AA AX74AA instead of MX77AA MX77AA when NT7X05 is already datafilled as an optional card, the tuple change is disallowed and the MAP displays the following message:

Info: NT7X05AA requires MX77 processor

Note 4: When field PECS6X45 is datafilled with AX74AA AX74AA instead of MX77AA MX77AA, the load name prefix in field LOAD changes from CRI to XRI. For example, CRI08xx (for MX77) changes to

Basic call processing (continued)

XRI08XX (for AX74AA). The following example shows sample datafill for table RCCINV when the RCC2 is datafilled for the NTAX74AA CAP.

MAP display example for table RCCINV datafilled for NTAX74AA CAP

```

Table: RCCINV

RCCNAME      FRTYPE FRNO SHPOS FLOOR ROW FRPOS  EQPEC  LOAD
-----
CARY RCC2 0
      1101 CRSC  0    5    0    C    0      MX85AA  XRI08xx

EXECTAB
-----
(POTS POTSEX) (KEYSET KSETEX) (RMM_TERM RSMEX) (ESALINES ESAEX) $

CSPM          CSLNKTAB
-----
LTC 1         (0) (1) (2) (3) (4) (5) (6) (7)  $

ESA INTRASW  OPTCARD          CMRLOAD          CONTMARK
-----
Y   Y                (MSG6X69) (UTR6)(CMR5 CMRAG03) (ISP16)  $

TONESET [PECS6X45] [E2LOAD] EXTINFO
-----
NORTHAM [AX74AA AX74AA] [AX74xxxx] CEXT 0 4 0 E 15 MX86AA L
    
```

Error messages for table RCCINV

The following error messages apply to RSC-S basic call processing in table RCCINV.

Error messages for table RCCINV (Sheet 1 of 2)

Error message	Explanation and action
Failed to allocate pslinks table.	This message indicates that no store is allocated for P-side tables.
Only one CMR card allowed.	This displays if you attempt to datafill more than one CMR card.
More than one OPTCARD specified for slot 6.	This displays if you attempt to datafill two optional cards on the physical slot 6 (UTR6 and CMR6).

Basic call processing (continued)**Error messages for table RCCINV (Sheet 2 of 2)**

Error message	Explanation and action
More than one OPTCARD specified for slot 6.	This displays if you attempt to datafill two optional cards on the physical slot 7 (UTR7 and CMR7).
PECS6X45 must be MX77AA for CPM's—Only MX77 processor can be used by CPM—PECS6X45 MX77AA is valid for CPM's only.	This displays if you attempt to datafill MX77 PEC for a non-CPM shelf such as RCC, and so forth.
Info: NT7X05AA requires MX77 processor	A user has attempted to datafill field PECS6X45 with AX74AA AX74AA instead of MX77AA MX77AA when NT7X05 is already datafilled as an optional card.

Datafilling table RCCPSINV

Table Remote Cluster Controller P-side link Inventory (RCCPSINV) contains only the P-side link assignments for the RCC2. Up to 54 (0-53) multiples of P-side link information may be datafilled for the RCC2.

Note: Physically, only 2 DS-1 C-side links are necessary, link 0 and link 2. The data control table for P-side links, table RCCPSINV, requires that link 1 be datafilled before link 2 can be datafilled. If only two links were required, which is not likely, link 1 would remain ManB. It is necessary to datafill for 3 links in this table.

**CAUTION****Potential extended outage**

Do not change the signaling format to B8ZS for P-side links connected to the RLCM, OPM, and OPAC until the NT6X51 LCM processors are upgraded to NT6X51DA. If you change the signaling format to B8ZS on links to the RLCM, OPM, and OPAC not provisioned with the NT6X51DA, you will not be able to restore service to these PMs if they become SysB or ManB. A software reload will be required and the signaling format must be changed back to ZCS before you reload and RTS the PMs.

Basic call processing (continued)

When an extension shelf is added, there are datafill restrictions for RCC2 P-side links connected to the extension shelf. The DS-1 and D-channel handler (DCH) links connected to the extension shelf can be datafilled only if an extension shelf was datafilled in RCCINV. All the links that connect to the extension shelf must be changed from DS-1/DCH to NILTYPE or DS30A in RCCPSINV prior to deleting the extension shelf from table RCCINV.

Some of the DCH interface cards are placed in the same physical slots as the DS-1 interface cards so they cannot coexist. As a result, the following pairs of links cannot be both datafilled for the same extension shelf:

- DCH link 14 and any of the DS-1 links 24-31
- DCH link 15 and any of the DS-1 links 32-39
- DCH link 13 and any of the DS-1 links 40-47

Up to ten DCH cards can be datafilled in table RCCPSINV.

The following table shows the datafill specific to Basic call processing for table RCCPSINV. Only those fields that apply directly to Basic call processing are shown. Refer to the *Translations Guide* for a description of the other fields.

Datafilling table RCCPSINV for RSC-S basic call processing (Sheet 1 of 2)

Field	Subfield or refinement	Entry	Explanation and action
RCCNAME		see subfields	RCC2 name. Enter the name of the RCC2. Subfields: SITE, PMTYPE, and RCCNO.
	SITE	character	Site. Enter the site name assigned to the remote location. It should also appear in table SITE.
	PMTYPE	RCC2	PM type. Enter RCC2 for the non-ISDN RCC2.
	RCC2NO	0-127	RCC2 number.
PSLNKTAB		see subfields	P-side link table. Subfields: PSLINK, PSDATA, and CONTMARK. Enter the vector. Note: Changes to fields with multiple entries should be made in the PROMPT mode only.
	PSLINK	0-53	P-side link. Enter the RCC2 P-side port number.
Note: PSDATA fields are datafilled depending on the AREASELCT value. If AREASELCT is DS30A, DCH, or NILTYPE, no other fields require datafill. If PSDATA is DS-1, complete fields CARRIDX and ACTION.			

Basic call processing (continued)**Datafilling table RCCPSINV for RSC-S basic call processing (Sheet 2 of 2)**

Field	Subfield or refinement	Entry	Explanation and action
	PSDATA	alphanumeric	<p>P-side link data. Enter DS-1 for links to remote-off-remote, DS30A for links to RMMs or LCMs. Otherwise, enter NILTYPE. RCC2 DS1 links are from 0 to 21 and DS30A links are from 21 to 53.</p> <p>DS1 links 1-7 and 9-19 are available for remotes. DS30A links 22 and 23 are reserved for the RMM. DS30A links 24 to 53 connect to LCMs.</p> <p>Note: LCMs attached to RCC2s must have message link (0 and 1) assignments separated by a minimum of four in table LCMINV. RCC2 NTMX74 I/F cards support 4 links each. Failure of an NTMX74 can cause E1 outage if all message links of an LCM resided on that card.</p>
CARRIDX		character	Carrier index. Enter the name to index into table CARRMTC. Enter a blank for the default template in table CARRMTC.
ACTION		Y	Action. Enter Y if the carrier should be removed from service when the OOS limit for frame, slip, errored-second, or severe errored-second is exceeded.
<p>Note: PSDATA fields are datafilled depending on the AREASELCT value. If AREASELCT is DS30A, DCH, or NILTYPE, no other fields require datafill. If PSDATA is DS-1, complete fields CARRIDX and ACTION.</p>			

Datafill example for table RCCPSINV

The following example shows sample datafill for RSC-S basic call processing in table RCCPSINV.

Basic call processing (continued)

MAP display example for table RCCPSINV

```

Table: RCCPSINV

RCCNAME          PSLNKTAB
-----
CARY RCC2 0  (0 DS-1 DEFAULT N) (1 DS-1 DEFAULT N)
(2 DS-1 DEFAULT N) (3 DS-1 DEFAULT N) (4 DS-1 DEFAULT N)
(5 DS-1 DEFAULT N) (6 DS-1 DEFAULT N) (7 DS-1 DEFAULT N)
(8 NILTYPE) (9 NILTYPE) (10 NILTYPE) (11 NILTYPE)
...
...
(21 DS30A) (22 DS30A) (23 DS30A) (24 DS30A)
(25 DS30A) (26 DS30A) (27 DS30A) (28 DS30A)
...
...
(44 NILTYPE) (45 NILTYPE) (46 NILTYPE) (47 NILTYPE)
(48 NILTYPE) (49 NILTYPE) (50 NILTYPE) (51 NILTYPE)
(52 NILTYPE) (53 NILTYPE) $
    
```

Error messages for table RCCPSINV

The following error messages apply to RSC-S basic call processing in table RCCPSINV.

Error messages for table RCCPSINV (Sheet 1 of 2)

Error message	Explanation and action
Failed to allocate pslinks tables.	Cannot allocate temporary store for P-side tables.
Cannot datafill &\$ in link &\$	P-side link restrictions for RCC2 prevent datafill (for example, if the first parameter is the link type that has been datafilled while the second parameter is the link number).
DS-1 not allowed on link &\$ when DCH datafilled on link &\$	P-side link restrictions for RCC2 prevent datafill (for example, when DCH is defined on link 0, 8, 16, DS-1 cannot be defined on ports 1-7, 9-15, and 17-23 respectively).
Only 54 pside links are allowed	The user attempted to to datafill more than 54 P-side links on the RCC2.

Basic call processing (continued)

Error messages for table RCCPSINV (Sheet 2 of 2)

Error message	Explanation and action
DS-1 not allowed in link # when there is no extension shelf.	The user attempted to datafill a DS-1 link to the extension shelf when no extension shelf has been datafilled.
DCH not allowed in link # when there is no extension shelf.	The user attempted to datafill a DCH link to the extension shelf when no extension shelf had been datafilled.
DS-1 not allowed in link # when DCH is in link #	The user attempted to datafill a DS-1 link whose card position is in the same physical slot as the DCH card of the DCH already datafilled.

Datafilling table LCMINV

Table Line Concentrating Module Inventory (LCMINV) lists data assignment for each bay associated with a local or remote LCM unit. The only field that is different for the RSC-S configuration is SITE.

The following table shows the datafill specific to Basic call processing for table LCMINV. Only those fields that apply directly to Basic call processing are shown. Refer to the *Translations Guide* for a description of the other fields.

Datafilling table LCMINV for RSC-S basic call processing (Sheet 1 of 3)

Field	Subfield or refinement	Entry	Explanation and action
LCMNM		see subfields	Line concentrating module name. Enter the LCM name. Subfields: SITE, FRNO, and UNITNO.
	SITE	alphanumeric	Site. Enter the site name assigned to the remote location.
	FRNO	0-511	Frame number Enter the LCM frame number.
	UNITNO	0-1	Unit number Enter the LCM unit number.
<p>Note: When datafilling fields link information (LNKINFO) or link map (LNKMAP), assure message links are not assigned to the same physical interface card. When the interface card supports two or more links, separate the message links by the number of links on the interface cards. This applies to all interface link types; DS-1, DS30, DS30A, or PCM-30. Table control will issue a warning if an attempt is made to assign message links on the same interface card. Assigning message links to the same interface card can cause an E1 outage (failure of all message links) if the card fails.</p>			

Basic call processing (continued)

Datafilling table LCMINV for RSC-S basic call processing (Sheet 2 of 3)

Field	Subfield or refinement	Entry	Explanation and action
FRTYPE		see list	Frame type. Enter the frame type in which the peripheral module equipment is mounted. Enter CRSC, for the RCC2 shelf, or CEXT.
Enter the location of the LCM in fields SHPOS, FLOOR, ROW, and FRPOS.			
EQPEC		BX30AB	Equipment PEC. Enter the PEC BX30AB for the LCME.
LOAD		alphanumeric	Load. Enter the load for the LCME.
CSPMNO		see subfields	C-side PM. Contains subfields PMTYPE and XPMNO.
	PMT	RCC2	PM type. Enter the type of peripheral attached to the C-side of the LCME.
	EXT_PMNO	0-199	PM number. Enter the PM number attached to the LCM C-side.
BICTST		Y or N	BIC relay test. Include the LCM in the next LCM BIC Relay Test (BRT) schedule.
MEMSIZE		see list	Memory size. Enter the memory size of the processor card used in the LCM. Entry values are 256K and 64K. The MEMSIZE field must be set to 256K if BICTST is set to yes or if XLCM overload feature is implemented.
LCMTYPE		LCME	LCM type and link information. Enter LCME for the enhanced LCM type or LCM. Subfields are RNGDATA and LCDI_INFO.
RNGDATA		see subfield	Ring data. Consists of subfield RGEQUIP.
	RGEQUIP	Y or N	Ringling equipment. Enter Y to select ring type.
<p>Note: When datafilling fields link information (LNKINFO) or link map (LNKMAP), assure message links are not assigned to the same physical interface card. When the interface card supports two or more links, separate the message links by the number of links on the interface cards. This applies to all interface link types; DS-1, DS30, DS30A, or PCM-30. Table control will issue a warning if an attempt is made to assign message links on the same interface card. Assigning message links to the same interface card can cause an E1 outage (failure of all message links) if the card fails.</p>			

Basic call processing (continued)**Datafilling table LCMINV for RSC-S basic call processing (Sheet 3 of 3)**

Field	Subfield or refinement	Entry	Explanation and action
	RNGTYPE	see list	Ringing type. Refinements are RINGCADENCE, FREQUENCIES, and PROMVOLT.
	LCDI_INFO	0-53	Line concentrating device ISDN information. Up to 18 vectors of link numbers, 0-53, of the C-side peripheral, in this case the RCC2. Note: LCMs attached to RCC2s must have message link (0 and 1) assignments separated by a minimum of four. NTMX74 I/F cards in the RCC2 support 4 links each. Failure of an NTMX74 card can cause an E1 outage if all message links of an LCM resided on that card.
Note: When datafilling fields link information (LNKINFO) or link map (LNKMAP), assure message links are not assigned to the same physical interface card. When the interface card supports two or more links, separate the message links by the number of links on the interface cards. This applies to all interface link types; DS-1, DS30, DS30A, or PCM-30. Table control will issue a warning if an attempt is made to assign message links on the same interface card. Assigning message links to the same interface card can cause an E1 outage (failure of all message links) if the card fails.			

Datafill example for table LCMINV

The following example shows sample datafill for RSC-S basic call processing in table LCMINV.

MAP display example for table LCMINV

```

Table: LCMINV

LCMMN      FRTYPE SHPOS FLOOR ROW FRPOS EQPEC  LOAD
-----
CARY 02 0   CRSC    4    3    D    1    BX30AB  CRC36xx

CSPMNO  MEMSIZE  BICTST   LCMTYPE  RGEQUIP
-----
RCC2  O   256K      N          LCME      Y

RNGTYPE  LCMSEL  LCMINFO
-----
C          HLCM    (24) (28) (26) (27)  $

```

Basic call processing (continued)

Note 1: The xx in field load stands for two letters, for example, BZ.

Note 2: LCM link info is listed starting with message links (MS) 0 and 1. The C-side peripheral links of the RCC2 are in parentheses.

Datafilling table RMMINV

Table Remote Maintenance Module Inventory (RMMINV) identifies an RLCM, RSC-S, or OPM site with the frame type, frame number, floor, row, frame position, PEC, PM load and executive program loaded, and C-side PM attached to each RMM. Memory is dynamically allocated and the maximum size of this table is 255 entries. Field CSPMINFO of an RMM can be an RCC2 as well as the LTC or RCC. The C-side links of RMM must be defined to link 22 and 23 of the RCC2.

The following table shows the datafill specific to Basic call processing for table RMMINV. Only those fields that apply directly to Basic call processing are shown. Refer to the *Translations Guide* for a description of the other fields.

Datafilling table RMMINV for RSC-S basic call processing (Sheet 1 of 2)

Field	Subfield or refinement	Entry	Explanation and action
RMMNAME		see subfields	RMM name. Enter the name for the RMM. Subfields: SITENM, PMTYPE, and RMMNO.
	SITENM	character	Site. Enter the site name assigned to the remote location. This entry should also appear in tables RCCINV, LCMINV, and SITE.
	PMTYPE	RMM	PM type. Enter RMM.
	RMMNO	0-63	RMM number. This number is unique by office, not by site.
FRTYPE		see list	Frame type. Enter CRSC for the RCC2 shelf. Enter CEXT for the RCC2 extension shelf. For the RLCM, enter RLCM.
Enter the location of the LCM in fields SHPOS, FLOOR, ROW, and FRPOS.			
EQPEC		alphanumeric	Equipment PEC. Enter 6X13AA for an RMM.
LOAD		alphanumeric	Load. Enter the load for the RMM. Be sure table PMLOADS contains this table.
EXECS		RSMEX	EXEC table. Enter the appropriate execs. For the RMM, the exec is RSMEX.

Basic call processing (continued)**Datafilling table RMMINV for RSC-S basic call processing (Sheet 2 of 2)**

Field	Subfield or refinement	Entry	Explanation and action
CSPMINFO		see subfields	C-side PM information. Subfields: RMMSELECTOR, CSIDEPM, and CSIDPORT.
	RMM SELECTOR	RMMRCC2	RMM selector. Enter the type of module where the RMM is located (RMMRCC or RMMRCC2).
	CSIDEPM	see subfields	C-side peripheral module. Subfields: PMT and EXT_PMNO.
	PMT	RCC2	PM type. Based on value in field RMMSELECTOR. Enter RCC2.
	EXTPMNO	0-127	External PM number. Enter the external PM number to which the RMM is attached. This number should also appear in table LCMINV or RCCINV. Note: If field RMMSELECTOR is RMMRCC2, datafill subfield CSIDPORT as follows.
	CSIDPORT	22 and 23	C-side port. Enter the C-side port connected to the RMM. Enter 22 and 23.

Datafill example for table RMMINV

The following example shows sample datafill for RSC-S basic call processing in table RMMINV.

MAP display example for table RMMINV

```

Table: RMMINV

RMMNAME          FRTYPE FRNO SHPOS FLOOR ROW FRPOS
-----
CARY RMM 0       CRSC   0   19   3   C   51
CARY RMM 1       CRSC   0   19   3   D   51

EQPEC           LOAD           EXECES           CSPMINFO
-----
6X13AA         RMD05A         RSMEX           RMMRCC RCC2 22
6X13AA         RMD05A         RSMEX           RMMRCC RCC2 23

```

Basic call processing (continued)

Error messages for table RMMINV

The following error messages apply to RSC-S basic call processing in table RMMINV.

Error messages for table RMMINV

Error message	Explanation and action
For RCC2 RMM allowed on P-side links 22 and 23.	This message reaffirms that an RMM must be defined on links 22 and 23 of an RCC2.

Datafilling table REXSCHED

Table routine exercise schedule (REXSCHED) contains the SREX test scheduling information required by the REX controller.

The following table shows the datafill specific to LCM REX testing. Only those fields that apply directly to LCM REX are shown. Refer to the *Translations Guide* for a description of the other fields.

Datafilling table REXSCHED for RSC-S basic operation (Sheet 1 of 2)

Field	Subfield or refinement	Entry	Explanation and action
REXTSTID		see subfield	REX tests identification. Subfield: REX_TEST_ID.
	REX_TEST_ID	see list	REX test ID. REX test identifiers are defined automatically by the system when inventory tables are datafilled. Examples: MS_REX_TEST, CM_REX_TEST, SLM_REX_TEST, LGC_REX_TEXT, MSB_REX_TEST, LCM_REX_TEST, and LCMCOV_REX_TEST.
ENABLE		Y or N	Enable REX test. Enable test schedule for specific REX identifier. Default: Y.
PERIOD		1-7 inclusive	Minimum number of days between consecutive REX schedules. Each REX test must be run at least once a week. Default: 1 (run REX every day).
Note: The LCMCOV_REX_TEST is performed only on LCMs, XLCMs, OPMs, and RLCMs.			

Basic call processing (continued)**Datafilling table REXSCHED for RSC-S basic operation (Sheet 2 of 2)**

Field	Subfield or refinement	Entry	Explanation and action
PARALLEL		1-99	Number of specific REX tests running parallel. Limit of concurrent REX tests running for a node type. For LCM_REX, the maximum concurrent tests that can be run is 4. For LCMCOV_REX tests, the availability of only one line test unit (LTU) in an LCM requires a maximum of 1. Default: 1.
DAYSDBL		see list	Days to disable REX testing. A list of days when REX testing will be disabled. values: MON, TUE, WED, THU, FRI, SAT, SUN, ALL or NONE. Each REX test must run at least once a week. The ALL option is included to suspend a REX test to facilitate system maintenance. Default: none.

Note: The LCMCOV_REX_TEST is performed only on LCMs, XLCMs, OPMs, and RLCMs.

Datafill example for table REXSCHED

The following example shows sample datafill for table REXSCHED.

MAP display example for table REXSCHED

Table: REXSCHED					
REXTSTID	ENABLE	PERIOD	PARALLEL		DAYSDBL
MS_REX_TEST	Y	1	1		NONE
CM_REX_TEST	Y	1	1		NONE
SLM_REX_TEST	Y	1	1		NONE
LGC_REX_TEST	Y	1	1		NONE
MSB_REX_TEST	Y	1	1		NONE
LCM_REX_TEST	Y	1	4		NONE
LCMCOV_REX_TEST	Y	1	1		NONE

Basic call processing (continued)**Datafilling table LNINV**

Table Line Circuit Inventory (LNINV) defines the site, line equipment number, and associated data for each line card circuit.

Datafilling table LNINV for RSC-S basic call processing

Field	Subfield or refinement	Entry	Explanation and action
LEN		see subfields	Line equipment number. Contains subfields SITE, FRAME, UNIT, LSG, and CIRCUIT.
	SITE	alphanumeric	Site. Enter the site assigned to the remote location.
	FRAME	0 to 99	Frame. Enter the frame number.
	UNIT	0 to 1	Unit. Enter the unit number.
	LSG	0 to 19	Line subgroup. For LCMs the range is 0-19.
	CIRCUIT	0 to 31	Circuit. Enter the line card circuit number.
CARDCODE		alphanumeric	Cardcode. Enter the appropriate line card for the office.
PADGP		character	Pad group. Enter the name of the pad group assigned to the line circuit in table PADATA.
STATUS		character	Status. Enter the line inventory availability status. Valid entries: HASU, WORKING, UNEQUIP, CUTOFF, or RESERVED.
GND		Y or N	Ground. Where the line is ground start enter Y(es). Otherwise enter N(o).
BNV		L or NL	Balanced network value. Enter L when the line circuit is configured for a loaded network. Otherwise, enter NL for a non-loaded network.
MNO		Y or N	Manual override. Enter Y(es) when the onhook balance network test is prevented from updating field BNV in this table. Otherwise, enter N(o) to allow the offhook balance network test to update field BNV.
	CARDINFO	see subfield	Card information. Subfield: CARDTYPE and its refinements.

Basic call processing (continued)**Datafill example for table LNINV**

The following example shows sample datafill for RSC-S basic call processing in table LNINV.

MAP display example for table LNINV

```

Table: RMMINV

RMMNAME          FRTYPE  FRNO  SHPOS  FLOOR  ROW  FRPOS
-----
CARY RMM 0       CRSC   0    19    3     C    51
CARY RMM 1       CRSC   0    19    3     D    51

EQPEC           LOAD          EXECES          CSPMINFO
-----
6X13AA         RMD05A        RSMEX          RMMRCC RCC2 22
6X13AA         RMD05A        RSMEX          RMMRCC RCC2 23

```

Datafilling table TRKGRP

Table Trunk Group defines data for each trunk group associated with the switching unit.. Each trunk group entry in table TRKGRP consists of a unique CLLI for the trunk group and number of other fields determined by the trunk group type field GRPTYP.

The following procedure shows datafill for table TRKGRP. This procedure contains only those fields for basic call processing. Refer to the *Translations Guide* for a description of the other fields.

Datafilling table TRKGRP for RSC-S basic call processing (Sheet 1 of 2)

Field	Subfield or refinement	Entry	Explanation and action
GRPKEY		see subfield	Group key. This field comprises subfield CLLI.
	CLLI	alphanumeric	Common language location identifier. Enter the CLLI code for the trunk group assigned in table CLLI.
<p>Note 1: Table TRKGRP can have up to 2047 trunk groups. The actual number is restricted by the number of CLLIs available to name the trunk groups.</p> <p>Note 2: The set of trunk group types available for a specific office is a function of hardware and software features and feature packages provided for the office by the operating company.</p>			

Basic call processing (continued)

Datafilling table TRKGRP for RSC-S basic call processing (Sheet 2 of 2)

Field	Subfield or refinement	Entry	Explanation and action
GRPINFO		see subfields	Variable group data. When trunk group type is MAINT, this field contains subfields GRPTYP, TRAFSNO, PADGRP, NCCLS, and CARD.
	GRPTYP	alphanumeric	Group Type. Enter the group type for the trunk group. For maintenance and test trunks, the range is ITL2, TTL2, LOOPA, MAINT, or SOCKT.
	TRAFSNO	0	Traffic separation number. Because this is not required for maintenance and test trunks, enter 0.
	PADGRP	see list	Pad group. Enter the name of the pad group assigned to the trunk group in table PADATA. For maintenance and test trunks, enter IAO (intra-office trunks). Otherwise, enter NPDGP.
	NCCLS	NCRT	No circuit class. Enter NCRT (no circuit).
	CARD	alphanumeric	Cardcode. Enter the PEC of the maintenance and test trunk.
<p>Note 1: Table TRKGRP can have up to 2047 trunk groups. The actual number is restricted by the number of CLLIs available to name the trunk groups.</p> <p>Note 2: The set of trunk group types available for a specific office is a function of hardware and software features and feature packages provided for the office by the operating company.</p>			

Datafill example for table TRKGRP

The following example shows sample datafill for RSC-S basic call processing in table TRKGRP.

Basic call processing (continued)**MAP display example for table TRKGRP**

```

Table:  TRKGRP

GRPKEY                                GRPINFO
-----
VER90      MAINT  0  NPDGP  NCRT  2X90AB
TTT        MAINT  0    IAO  NCRT  2X96AA
TTU        MAINT  0    IAO  NCRT  2X47AA
LTU        MAINT  0    IAO  NCRT  2X11AA
RLMVER90   MAINT  0    IAO  NCRT  2X90AB
OG_1      TO    0  TLD  NCRT    IE  MIDL  7  N
OG_2      TO    0  TLD  NCRT    IE  MIDL  4  N

RSC TIP
TI  0  ELO  NCRT  IE  NPRT  NSCR  704  LCL  N  N

RCC20IBNTO
IBNTO  0  ELO  NCBN  RCC20  0  MIDL  ANSDISC
0  N  O  1  8  9  N  N  N  N  N  N  N  $
RCC20IBNTI
IBNTI  0  ELO  NCRT  RCC20  0  0  3204001  ANSDISC
0  Y  N  N  Y  N  Y  Y  0  0  N  N  N  N  N  $

```

Datafilling table TRKSGRP

Table Trunk Subgroup (TRKSGRP) lists the supplementary information for each subgroup that is assigned to one of the trunk groups listed in table TRKGRP.

Input data must be specified for at least one subgroup or a maximum of two subgroups for each trunk group listed in table TRKGRP, excluding trunk groups defined as maintenance (MAINT) group types.

Note: The trunk subgroup data for maintenance and test trunks, excluding subgroup 1 of trunk groups with code TTU, is automatically produced by the trunk group datafill.

Basic call processing (continued)

The following table shows the datafill specific to Basic call processing for table TRKSGRP. Only those fields that apply directly to Basic call processing are shown. Refer to the *Translations Guide* for a description of the other fields.

Datafilling table TRKSGRP for RSC-S basic call processing (Sheet 1 of 2)

Field	Subfield or refinement	Entry	Explanation and action
SGRPKEY		see subfields	Subgroup key. This field comprises subfields CLLI and SGRP.
	CLLI	alphanumeric	Common language location identifier. This subfield contains the code assigned in the CLLI table to the trunk group to which the subgroup belongs.
	SGRP	0	Subgroup number. This subfield contains the number assigned to the trunk subgroup. For maintenance and test trunks, the number is 0.
CARDCODE		see list	Card code. This field lists the product engineering code of the maintenance and test trunk.
SGRPVAR		see subfields	Variable subgroup data. For standard signaling, this field contains subfields SIGDATA, DIR, OPULSTYP, OSTARTSG, IDGTIME, NUMSTOPS, CCONT, RNGBCK, ESUPR, SAT, REMBSY, DIALMODE, and TRKGDTIM.
	SIGDATA	STD	Signaling data. This subfield lists the signaling code (STD for standard signalling).
	DIR	OG	Direction. For maintenance and test trunks, the entry is OG (outgoing).
	OPULSTYP	NP	Ootgoing type of pulsing. For maintenance and test trunks, the entry is NP (no pulsing).
	OSTARTSG	WK	Outgoing start dial signal. For maintenance and test trunks, the entry is WK (wink).
<p>Note 1: Memory is allocated for the number of trunk subgroups by field SIZE in table DATASIZE for the entry with field DATSKEY equal to TRKSGRP.</p> <p>Note 2: The maximum number of trunk subgroups is equal to twice the number of trunk groups.</p> <p>Note 3: The maximum number of trunk subgroups that can be assigned is 4096.</p>			

Basic call processing (continued)**Datafilling table TRKSGRP for RSC-S basic call processing (Sheet 2 of 2)**

Field	Subfield or refinement	Entry	Explanation and action
SGRPVAR (continued)	IDGTIME	2	Interdigital timing. For maintenance and test trunks, this value is 2.
	NUMSTOPS	0	Number of stops/goes. For maintenance and test trunks, this value is 0.
	CCONT	MW	Coin control. For maintenance and test trunks, the entry is MW (multiwink).
	RNGBCK	IB	Ringback. For maintenance and test trunks, the entry is IB (inband).
	ESUPR	N	Echo suppressor. For maintenance and test trunks, the entry is N (no echo suppressor).
	SAT	N	Satellite. For maintenance and test trunks, the entry is N (no satellite).
	REMBSY	N	Remote make busy. For maintenance and test trunks, the entry is N (feature not assigned).
	DIALMODE		Dial mode. For maintenance and test trunks, this subfield is blank.
	TRKGDTIM	numeric	Trunk guard timing. For maintenance and test trunks, this value is 16 (160 ms elapse time interval before the trunk is returned to the idle link list after trunk disconnect).
Note 1: Memory is allocated for the number of trunk subgroups by field SIZE in table DATASIZE for the entry with field DATSKEY equal to TRKSGRP.			
Note 2: The maximum number of trunk subgroups is equal to twice the number of trunk groups.			
Note 3: The maximum number of trunk subgroups that can be assigned is 4096.			

Datafill example for table TRKSGRP

The following example shows sample datafill for RSC-S basic call processing in table TRKSGRP.

Basic call processing (continued)

MAP display example for table TRKSGRP

```

Table: TRKSGRP

SGRPKEY  CARDCODE

-----
VER90 0    2X90AB
        STD OG NP      WK  0 0 NO NO F N N 17
TTT 0    2X96AA
        STD OG NP      WK  0 0 NO NO F N 17

LTU 0    2X11AA
        STD OG NP      WK  0 0 NO NO F N 17
RLMVER90 0 2X90AB
        STD OG NP      WK  0 0 NO NO F N 17
OG_1    DS-1SIG
        STD OG DP      IM 70 0 NO NO N N 70
RCC20TO 0  DS-1SIG
        STD 2W MF WK N 7 7 MF WK 7 0 N NO NO N N N M 70
  
```

Datafilling table TRKMEM

Table Trunk Member (TRKMEM) lists the data associated with each trunk assigned to one of the trunk groups and subgroups specified in tables TRKGRP and TRKSGRP. For RSC-S, this table identifies the circuits associated with static trunks, dynamic trunks, and the test equipment used to test lines and trunks.

Basic call processing (continued)

The following table shows the datafill specific to Basic call processing for table TRKMEM. Only those fields that apply directly to Basic call processing are shown. Refer to the *Translations Guide* for a description of the other fields.

Datafilling table TRKMEM for RSC-S basic call processing

Field	Subfield or refinement	Entry	Explanation and action
CLLI		alphanumeric	Common Lanaguage Location Identifier. Enter the code assigned in table CLLI to the trunk group of which the trunk is a member.
EXTRKNM		0-9999	External trunk number. Enter the external trunk number assigned to the trunk.
SGRP		0 or 1	Subgroup number. Enter the subgroup number to which the trunk is assigned. Enter 0 for maintenance and test trunks, 1 for others.
MEMVAR		see subfield	Variable data for members. For RSC-S applications, this field varies according to whether the trunk is part of an interoffice trunk or a maintenance trunk. For an interoffice trunk, the subfield is PMTYPE and its refinements.
	PMTYPE	RCC2	Peipheral module type. This field is the PM type on which the trunk is mounted. Enter RCC2. Refinements are datafilled as follows.
	RCC2NO	0-511	RCC2 number. This field is the RCC2 number.
	RCCCKTNO	0-53	RCC2 circuit number. This field is the RCC2 circuit number. Enter the RCC2 card number to which the trunk group member is assigned.
	RCCCKTTS	1-24	RCC2 time slot number. Enter the RCC2 time slot number to which the trunk group member is assigned.
<p>Note 1: Memory is allocated for the total number of trunks specified in field TRKGRSIZ in table CLLI for the appropriate trunk groups.</p> <p>Note 2: Table size may be increased with data present by changing field TRKGRSIZ in table CLLI for the appropriate trunk groups.</p>			

Datafill example for table TRKMEM

The following example shows sample datafill for table TRKMEM.

Basic call processing (continued)

MAP display example for table TRKMEM

Table: TRKMEM

CLLI	EXTRKNM	SGRP	MEMVAR
RCC20TI	0	0	RCC2 0 2 4
RCC20T2	0	0	RCC2 0 2 4

Datafilling table ALMSCGRP

Table Alarm Scan Group (ALMSCGRP) records circuit equipment, location, and type of circuit card containing scan points.

The following table shows datafill specific to Basic call processing for table ALMSCGRP. Only those fields that apply directly to Basic call processing are shown. Refer to the *Translations Guide* for a description of the other fields.

Datafilling table ALMSCGRP for RSC-S basic call processing

Field	Subfield or refinement	Entry	Explanation and action
SCGROUP		0-255	Scan group. Enter the scan group number.
TMTYPE		MTM, OAU, RMM	Trunk module type. Enter the type of trunk module on which the circuit is mounted. Entry values: MTM, OAU, and RMM.
TMNO		0-255	Trunk module number. Enter the number of the trunk module on which the circuit is mounted: TMTYPE EntryOAU OMTM 0-255
TMCKTNO		0-23	Trunk module circuit number. Enter the trunk module circuit number to which the circuit is assigned.
CARDCODE		alphanumeric	Cardcode. Enter the PEC of the alarm card.

Datafill example for table ALMSCGRP

The following example shows sample datafill for table ALMSCGRP.

Basic call processing (continued)**MAP display example for table ALMSCGRP**

Table: ALMSCGRP

SCGROUP	TMTYPE	TMNO	TMCKTNO	CARDCODE
0	MTM	1	1	3X82AA
1	MTM	3	1	3X82AA
2	MTM	1	7	3X84AA
3	MTM	1	10	0X10AA
.
21	RMM	2	11	0X10AA

Datafilling table ALMSDGRP

Table Alarm Signal Distributor Group (ALMSDGRP) records the circuit equipment, location, and type of circuit card containing SD points.

The following table shows the datafill specific to Basic call processing for table ALMSDGRP. Only those fields that apply directly to Basic call processing are shown. Refer to the *Translations Guide* for a description of the other fields.

Datafilling table ALMSDGRP for RSC-S basic call processing

Field	Subfield or refinement	Entry	Explanation and action
SDGRP		0-255	Signal distributor group. Enter the signal distributor group number.
TMTYPE		see list	Trunk module type. Enter the type of trunk module on which the circuit is mounted. Entry values: MTM, OAU, and RMM.
TMNO		0-255	Trunk module number. Enter the number of the trunk module on which the circuit is mounted: TMTYPE Entry OAU OMTM 0-255
TMCKTNO		0-23	Trunk module circuit number. Enter the trunk module circuit number to which the circuit is assigned.
CARDCODE		alphanumeric	Cardcode. Enter the PEC of the alarm card.

Basic call processing (continued)

Datafill example for table ALMSDGRP

The following example shows sample datafill for RSC-S basic call processing in table ALMSDGRP.

MAP display example for table ALMSDGRP

Table: ALMSDGRP

SDGROUP	TMTYPE	TMNO	TMCKTNO	CARDCODE
0	MTM	1	0	3X82AA
1	MTM	3	0	3X82AA
2	MTM	1	6	3X84AA
4	MTM	1	4	2X57AA
5	MTM	1	5	2X57AA
6	MTM	1	18	2X57AA
8	MTM	6	18	2X57AA
9	MTM	6	19	2X57AA
10	MTM	9	18	2X57AA
11	MTM	9	19	2X57AA
8	MTM	6	18	2X57AA
.
22	MTM	12	18	2X57AA
23	MTM	12	19	2X57AA

Datafilling table ALMSD

Table Alarm Signal Distributor Point (ALMSD) identifies the function to be performed by each of the assigned SD points in the alarm signal distributor groups.

The following table shows the datafill specific to Basic call processing for table ALMSD. Only those fields that apply directly to Basic call processing are shown. Refer to the *Translations Guide* for a description of the other fields.

Datafilling table ALMSD for RSC-S basic call processing (Sheet 1 of 2)

Field	Subfield or refinement	Entry	Explanation and action
FUNCTION		alphanumeric	Function. Enter the alarm function.
SDGROUP		0-255	Signal distributor group. Enter the signal distributor group to which the SD point belongs.
POINT		0-7	Signal distributor point. Enter the SD point number in the signal distributor group.

Basic call processing (continued)**Datafilling table ALMSD for RSC-S basic call processing (Sheet 2 of 2)**

Field	Subfield or refinement	Entry	Explanation and action
NORMALST		0 or 1	Normal state. Enter the normal state of the SD point. Entry values: 0 (if the SD point is off, or open, normally) and 1 (if the SD point is on, or closed, normally).
AUDIBLE		Y or N	Audible. Enter Y if the signal distributor point is to be reset when the audible alarm reset key is operated. Otherwise, enter N.
LAMPTEST		Y or N	Lamp test. Enter Y if the SD point is to be included in the lamp test. Otherwise, enter N.

Datafill example for table ALMSD

The following example shows sample datafill for RSC-S basic call processing in table ALMSD.

MAP display example for table ALMSD

Table: ALMSD

```

FUNCTION SDGROUP POINT NORMALST AUDIBLE LAMPTEST
-----
EXPILPWR      2      6      0      N      N
EXPILDMS      2      5      0      N      N
NTALMXFR      2      4      0      N      N
LN101TST      2      3      0      N      N
  OAUFAIL      0      0      1      N      N
  .            .      .      .      .      .
  .            .      .      .      .      .
  .            .      .      .      .      .
  LMMNV        6      6      0      Y      N
  PREFLRF      0      6      0      N      N

```

Datafilling table ALMSC

Table Alarm Scan (ALMSC) identifies the function to be performed by each of the assigned scan points in the alarm scan groups.

Basic call processing (continued)

The following table shows the datafill specific to Basic call processing for table ALMSC. Only those fields that apply directly to Basic call processing are shown. Refer to the *Translations Guide* for a description of the other fields.

Datafilling table ALMSC for RSC-S basic call processing (Sheet 1 of 2)

Field	Subfield or refinement	Entry	Explanation and action
FUNCTION		alphanumeric	Function. Enter the alarm function.
SCGROUP		0-255	Scan group. Enter the scan group to which the scan point belongs.
POINT		numeric	Scan point. Enter the scan point number within the scan group.
NORMALST		0 or 1	Normal state. Enter the normal state of the scan point. Entry values: 0 (if the scan point is normally off or open) and 1 (if the scan point is normally on or closed).
REPORT		Y or N	Report. Enter Y if an alarm report is to be logged. Otherwise, enter N.
ALM		CR, MJ, MN, NA	Alarm. Enter the type of alarm to be activated: Entry values are CR (critical alarm), MJ (major alarm), MN (minor alarm), and NA (no alarm).
LOGIC		see subfields	Logic. Subfields: LOGIC, SDFUNCT, ALMGRP, ALMXFR, and CONTMARK.
	LOGIC	Y or N	Logic. Enter Y if the logic associated with the function is fixed. Otherwise enter N.
	SDFUNCT	alphanumeric	Signal distributor function. Enter the signal distributor function or functions associated with a specific scan point.
	ALMGRP	Y or N	Alarm group. Enter Y if the alarm function is to be invoked when the alarm grouping key is activated. Enter N if the alarm function is to be implemented at all times regardless of the alarm grouping key.

Basic call processing (continued)**Datafilling table ALMSC for RSC-S basic call processing (Sheet 2 of 2)**

Field	Subfield or refinement	Entry	Explanation and action
	ALMXFR	Y or N	Alarm transfer. Enter Y if the alarm function is to be invoked when the alarm transfer key is activated. Otherwise enter N.
	CONTMARK	+ or \$	Continuation mark. Where the record is other than the last for a specific scan point, enter a plus sign (+), which indicates additional data for the scan point is specified in the next record. Where the record is the last for a specific scan point, enter a dollar sign (\$).

Datafill example for table ALMSC

The following example shows sample datafill for RSC-S basic call processing in table ALMSC.

MAP display example for table ALMSC

```

Table: ALMSC

FUNCTION SCGROUP POINT NORMALST REPORT ALM LOGIC
-----
MJSUCFLR  0      2    0  N  MJ  N  (PREFLRMJ Y N
          (MJXFR N Y)
          (MJALMAUD1 N N)
          (MJOTHVIS Y N)
          (MJALMAUD2 N N) $
MNSUCFLR  0      3    0  N  MN  N  (PREFLRMN Y N)
          (MNXFR N Y)
          (MNALMAUD Y N)
          (MNOTHVIS Y N) $
.
.
.
RSC-S0_ABS_ALM  20  2  0  Y  MN  N  (ABAUD N N)
          (ABSVIS N N)
          (EXPILDMS N N)
          (MNXFR N Y) $

```

Datafilling table MTAMDRVE

The metallic test access (MTA) network is a matrix of vertical and horizontal crosspoints, comparable to a minibar, that connects specified verticals to horizontal within the MTA. The MTA is used to connect test equipment

Basic call processing (continued)

connected to a horizontal, to a circuit requiring testing, which is connected to a vertical.

An MTA network of the required size can be constructed by the interconnection of a number of smaller minibar circuits, which are used as building block components. The NT3X09AA driver is used to allow metallic test access to remote line concentrating devices, including the LCMs off of the RCC2. The NT3X09AA is a four vertical by eight horizontal circuit. The NT3X09BA is an eight vertical by eight horizontal circuit. The following figure illustrates the MTA matrix.

MTA matrix

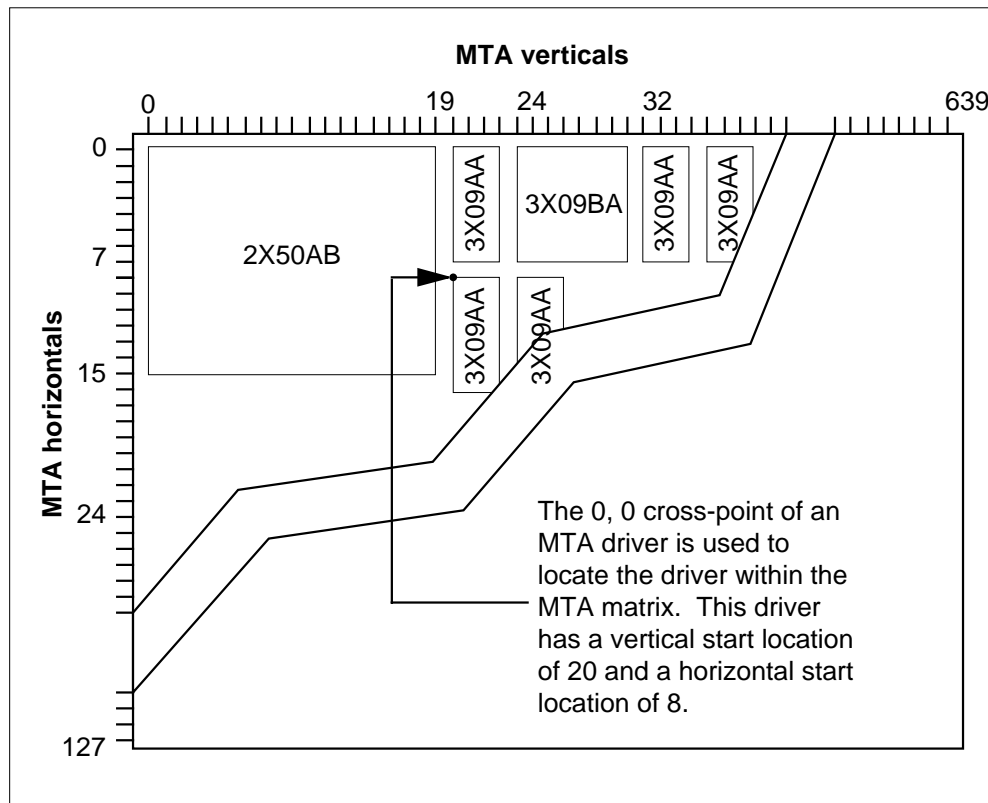
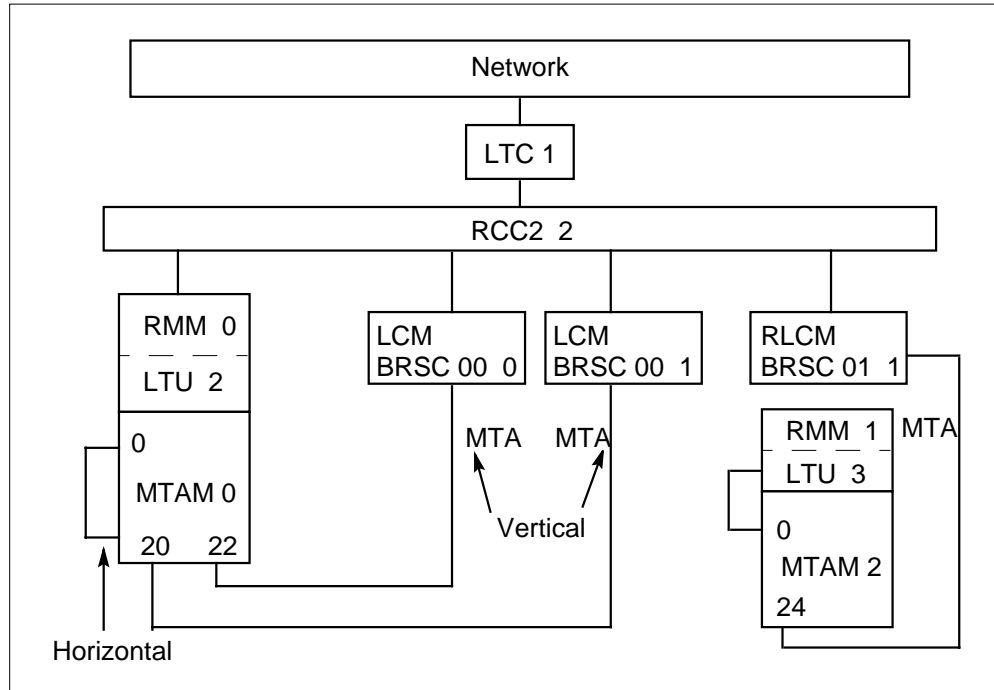


Table MTA Minibar Driver (MTAMDRVE) specifies the physical location and the type of the minibar driver assigned to the minibar switch. The NT2X50AB driver is part of the NT2X46 minibar switch. The NT3X09 driver has relays on the card itself and does not require an associated minibar switch. Each minibar driver is identified by its 0, 0 crosspoint in the matrix. The following figure provides an example of the MTA configuration.

Basic call processing (continued)

MTA matrix



The following table shows the datafill specific to Basic call processing for table MTAMDRVE. Only those fields that apply directly to Basic call processing are shown. Refer to the *Translations Guide* for a description of the other fields.

Datafilling table MTAMDRVE for RSC-S basic call processing (Sheet 1 of 2)

Field	Subfield or refinement	Entry	Explanation and action
MTAMEM		0-255	Metallic test access minibar driver member. Enter the MTA driver member number. This is the key to the table.
VERT		0-639	MTAM driver vertical start location. Enter the vertical start location for the MTAM driver.
HORIZ		0-127	MTAM driver horizontal start location. Enter the horizontal start location for the MTAM driver.
TMTYPE		RMM	Trunk module type. Enter the type of trunk module on which the minibar driver is mounted.
TMNO		0-255	Trunk module number. Enter the number assigned to the maintenance trunk module (MTM).

Basic call processing (continued)

Datafilling table MTAMDRVE for RSC-S basic call processing (Sheet 2 of 2)

Field	Subfield or refinement	Entry	Explanation and action
TMCKTNO		numeric	Trunk module circuit number. Enter the circuit number of the MTM or RMM to which the minibar driver is assigned.
MTACARD		2X50AB, 3X09AA, 3X09BA	MTAM driver card. Enter the card code for the metallic test access minibar driver card.

Datafill example for table MTAMDRVE

The following example shows sample datafill for RSC-S basic call processing in table MTAMDRVE.

MAP display example for table MTAMDRVE

Table: MTAMDRVE

MTAMEM	VERT	HORIZ	TMTYPE	TMNO	TMCKNO	MTACARD
1	20	0	RMM	0	10	3X09AA
1	22	0	RMM	0	10	3X09AA
2	24	0	RMM	1	10	3X09AA

Datafilling table MTAVERT

The Metallic Test Access vertical connection table identifies the vertical connectivity to the MTA matrix. Two types of connections are allowed: single and multiple. Up to 32 LCMs can share a metallic test pair.

The following table shows the datafill specific to Basic call processing for table MTAVERT. Only those fields that apply directly to Basic call processing are shown. Refer to the *Translations Guide* for a description of the other fields.

Datafilling table MTAVERT for RSC-S basic call processing (Sheet 1 of 2)

Field	Subfield or refinement	Entry	Explanation and action
VERT		numeric	Vertical. Enter MTA vertical connection number.
VERTCONN		M or S	Vertical connection. Enter M for multiple connections, S for single connections. Up to 32 LCM modules can share a metallic test pair.

Basic call processing (continued)**Datafilling table MTAVERT for RSC-S basic call processing (Sheet 2 of 2)**

Field	Subfield or refinement	Entry	Explanation and action
SELECTOR		O	Selector type. Use only selector O when the VERTCONN entry is M. Subfields SITE, FRAME, UNIT, and CONTMARK must be datafilled after the selector, a vector of 32 entries maximum.
	SITE	alphanumeric	Site name. Enter the remote location name.
	FRAME	numeric	Frame number. Enter the frame number.
	UNIT	numeric	Unit number. Enter the unit number.
	CONTMARK	+ or \$	Continuation mark. Enter a plus sign (+) to add data on the next record. Otherwise, enter a dollar sign (\$) after the last record.

Datafill example for table MTAVERT

The following example shows sample datafill for RSC-S basic call processing in table MTAVERT.

MAP display example for table MTAVERT

Table: MTAVERT					
VERT	VERTCONN				
20	S	L	CARY	00	0
22	S	L	CARY	00	1

Datafilling table MTAHORIZ

Table Metallic Test Access Horizontal Connection (MTAHORIZ) lists the assignment of *horizontal agents* to a horizontal and horizontal group of MTAMs. Horizontal agents include line test units (LTU), metallic test units (MTU), operator verification, metallic jacks (MJACK), incoming test access trunks, extended metallic test access, and short circuits.

Different horizontal agents may use the same horizontal but must be associated with different MTAMs (or horizontal groups). A maximum of 160 different horizontal agents is allowed for a given horizontal.

Basic call processing (continued)

A maximum of 32 MTAMs can be multiplied (grouped) to connect to a single horizontal agent. A horizontal agent can only be used once.

The following table shows the datafill specific to Basic call processing for table MTAHORIZ. Only those fields that apply directly to Basic call processing are shown. Refer to the *Translations Guide* for a description of the other fields.

Note 1: No horizontals are reserved for dedicated LTUs; and, nondedicated LTUs have no restriction on assignment.

Note 2: When an LTU is assigned to the host switching unit, the horizontal to which it is assigned is multiplied to all minibar switches that are assigned to the host switching unit. When an LTU is assigned to a remote location, the horizontal to which it is assigned is multiplied to all minibar switches that are assigned to the remote location.

Note 3: When the minibar switch is located at the host switching unit, no assignment restriction exists for the assignment of incoming test and operator verification trunks. One horizontal is required for each incoming test access trunk and operator verification trunk.

Note 4: Where the MTA configuration is small or medium, the horizontals to which the incoming test access and operator verification trunks are assigned are multiplied to all minibar switches that are located at the host switching unit.

Note 5: When the minibar switch is remote from the host switching unit, all horizontals are available for the assignment of incoming test access trunks, operator verification trunks, and for the extension of metallic test access feature.

Note 6: One horizontal is required for each incoming test access trunk, operator verification trunk, and for each vertical on the host minibar switch that is assigned to a horizontal on the minibar switch located at the remote or host location.

Note 7: The number of metallic jacks in each DMS office is restricted to 256.

Note 8: For assignment of the LTUs, incoming test access, and operator verification trunks to trunk group, trunk subgroup, and trunk member tables, see tables CLLI, TRKGRP, TRKSGRP, and TRKMEM.

Note 9: An LTU or MTU must be datafilled in table TRKMEM before being added to table MTAHORIZ. If the LTU or MTU is deleted from the TRKMEM table, the corresponding tuple in table MTAHORIZ is marked as deleted, but is automatically restored if the LTU or MTU is readded to table TRKMEM.

Basic call processing (continued)

Note 10: The memory for this table is dynamically allocated up to a maximum of 2000 tuples.

Datafilling table MTAHORIZ for RSC-S basic call processing (Sheet 1 of 2)

Field	Subfield or refinement	Entry	Explanation and action
HORIZ		0-127	MTA horizontal. Enter the MTA horizontal connected to test equipment (horizontal agent).
HORIZGRP		0-159	MTA horizontal group. Enter the horizontal group number which identifies the horizontal and its horizontal agent as a unique tuple. The purpose of the horizontal group is to allow assignment of different test equipment on the same MTA horizontal.
HORIZAGT			This field contains several subfields which depend on the SELECTOR value.
SELECTOR		character	Selector. Range is S, L, T, B, E, MJ, J, and LA.
		S	Enter S for a timed short circuit.
		L	Enter L for LTU or MTU assignment. Complete subfields CLLI, EXTRKNM, and ALTUSE.
		T	Enter T for incoming test access or operator verification trunk assignment and complete subfields CLLI and EXTRKNM.
		B	Enter B for a board-to-board dedicated horizontal and complete subfield BBTNR.
		E	Enter E to multiply a horizontal of a minibar switch from a host or remote to the vertical of a host minibar switch. Complete subfield EMTAVERT.
		MJ	Enter MJ for metallic connection to the tip and ring of the subscriber line and complete subfields CLLI and MJACKNUM.
SELECTOR (continued)		J or LA	Selectors J and LA are for licensee use only.
	CLLI	alphanumeric	Common language location identifier
		LTU	Enter LTU for line test unit.

Basic call processing (continued)

Datafilling table MTAHORIZ for RSC-S basic call processing (Sheet 2 of 2)

Field	Subfield or refinement	Entry	Explanation and action
MTAGRP		MTU	Enter MTU for metallic test unit.
		alphanumeric	For operator verification of an incoming test access trunk, enter the alphanumeric code representing this trunk group in table CLLI.
		MJACK	Enter MJACK for metallic jack.
	EXTRKNM	0-9999	External trunk number. Enter the external trunk number assigned in table TRKMEM to the line test unit, metallic test unit, operator verification trunk, or incoming test access trunk.
	ALTUSE	Y or N	Automatic Line Test Use. Enter Y to use line test equipment for automatic line testing (ALT). Otherwise, enter N.
	BBTNR	0-7	Board-to-board testing number. Enter the number of the board-to-board set with which this horizontal is associated.
	EMTAVERT	0-639	Extended metallic test access column. Enter the associated vertical on the MTA in the host to which the horizontal is connected.
	MJACKNUM	1-256	Metallic jack number. Where the entry in subfield CLLI is MJACK, enter the metallic jack number.
		see subfields	MTA group. This field contains a list of MTA drivers that multiply to the test equipment. This field is a vector of up to 32 multiples of subfields MTAMEM, HORIZ, and CONTMARK.
		MTAMEM	0-255
	HORIZ	0	This field is read-only. It provides information about the physical horizontal to which the MTA drivers are connected. Enter 0 to satisfy table control.
	CONTMARK	+ or \$	Continuation mark. Enter a plus sign (+) to add data on the next record. Otherwise, enter a dollar sign (\$) after last record.

Basic call processing (end)

Datafill example for table MTAHORIZ

The following example shows sample datafill for RSC-S basic call processing in table MTAHORIZ.

MAP display example for table MTAHORIZ

Table: MTAHRIZ			
MTAMEM	HORIZGRP	HORIZAGT	MTAGRP
8	0	L LTU 0 Y	(0 0)(2 0) \$

Translation verification tools

Basic call processing does not use translation verification tools.

SERVORD

Basic call processing does not use SERVORD.

Custom Local Area Signaling Services

Functional groups

RES00001

RES00003

RES00006

Feature packages

NTXQ70AA Universal Access to CLASS

NTXA01AA Calling Number Display

NTXA82AA Enablers CLASS LIOD

Release applicability

XPM05 and up

Prerequisites

Custom Local Area Signaling Services (CLASS) requires the following feature packages:

- NTX270AA New Peripheral Maintenance Package
- NTX413AB Enhanced Call Forwarding
- NTX824AB Enhanced Call Waiting
- NTX898AA Variable Speed Call Access Code
- NTX269AA Universal Tone Receiver Software

CLASS features and TR compliancy

Analog Display Services Interface (ADSI) and Spontaneous Call Waiting Identification (SCWID) features provide the capability to deliver CLASS features to customer premises equipment (CPE) that are compliant with Bellcore specifications TR-30, TR-575, and TR-1273.

The Deluxe SCWID (DSCWID) feature provides an interface to CPEs compliant with Bellcore specification TR-416. ADSI and DSCWID CLASS features can be added to RES and IBN Line Class Code (LCC) subscriber lines by using the Service Order System (SERVORD).

Custom Local Area Signaling Services (continued)

The following prerequisites are necessary to operate Bellcore compliant CLASS features ADSI and DSCWID:

- NTXP91AB ADSI Service Protocol Enablers
- NTXN97AB Call Waiting Display
- NTXQ91AA Enhanced Call Waiting Display

Description

CLASS features provide calling line identification and call management features to subscriber lines connected to an RSC-S. ADSI Services Protocol supports display-based CLASS features on ADSI-compatible CPEs. Following is a partial list of residential (RES) subscriber features. For a complete listing of feature group options see table FTRGOPTS in the *Translation Guide*.

- AR—Automatic Recall
- CFDA—Call Forward Don't Answer
- CWT—CLASS Message Waiting Indicator
- CNAMD—Calling Name Display
- CND—Calling Number Display
- DDN—Dialable Delivery Number
- CWT—Call Waiting
- DSCWID—Spontaneous Call Waiting With Disposition

Operation

ADSI signaling protocol allows downloading of softkey and display information to an ADSI-compatible CPE. Data is sent from the central control (CC) to the CLASS modem resource (CMR) card in the RSC-S. Static data download to the CMR card, of some of the information required to implement these features, reduces the amount of data the CC must process in real time. To implement CLASS features, the CC must maintain close synchronization with the CPE at all times. The CC records historical information concerning CLASS call processing and disposition. Some CLASS features may not be supported during emergency stand-alone (ESA).

Spontaneous Call Waiting With Disposition (DSCWID) is a CLASS feature that allows a subscriber to receive caller identification (CID) information from a call waiting to be connected, while the subscriber is off-hook. DSCWID allows the subscriber to control the disposition of incoming calls while an off-hook stable call exists. Default treatments to be applied, when the

Custom Local Area Signaling Services (continued)

subscriber does not respond to a call waiting alerting tone, are datafilled in the office tables.

Bellcore TR-416 describes requirements for DSCWID and specifies how this feature interfaces with the following sets:

- ADSI—screen-based CPE capable of displaying options
- SCWID—non-ADSI CPE capable of off-hook delivery of CID data
- 2500—non-ADSI CPEs that are able to signal dual tone multifrequency (DTMF) but are not capable of off-hook delivery of CID data

Translations table flow

Standard translations data flow is unaltered by this package.

Limitations and restrictions

A Bellcore compliant CPE with ADSI display capability is required to receive and display calling number information. Noncomplying CPEs that signal with DTMF can use CLASS features, including DSCWID, not dependent on ADSI. However, without the capability of displaying caller and softkey information and because of precise signaling requirements, a subscriber with a non-ADSI set will only be able to use a subset of the available options.

The DSCWID CLASS feature

- is not supported on Meridian business sets (MBS) or ISDN lines
- is not compatible with the Do Not Disturb (DND) feature
- cannot be added to a line that already has the Call Hold (CHD) option

DSCWID can be assigned to a subscriber line with no CID features assigned. If the subscriber uses ALLCID as the off-hook delivery type, at least one of the following CLASS display options must be either previously or concurrently assigned to a line:

- Calling Number Delivery (CND)
- Calling Name Delivery (CNAMD)
- Dialable Directory Number (DDN)

Assigning DSCWID to a line using SERVORD automatically assigns the Call Waiting Option (CWT) to that line and replaces any older versions of Spontaneous Call Waiting (SCWID).

The service script that must be resident in a DSCWID CPE to enable the display and control of softkey options is different for proprietary and Bellcore

Custom Local Area Signaling Services (continued)

compliant sets. The operating company must provide the service script as part of the conversion service on the subscriber line.

Additional RSC-S hardware requirements to implement Bellcore-compliant ADSI and DSCWID CLASS features are as follows:

- The combined messaging and tone generator circuit card with ADSI (NT6X69AD) must be installed.
- The TONESET field in table RCCINV must be set to North American ROM-based toneset with ADSI tone (NORTHAA) when NT6X69AD is used.
- The class modem resource (CMR) card (NT6X78AB) must be installed and datafilled with firmware version CMR03A or later. After datafill, the CMR must be busied and returned to service to activate CLASS ADSI-compatible features.
- A universal tone receiver (UTR) card (NT6X92BB) must be installed, datafilled, and available at call time.

Interactions

Custom Local Area Signaling Services has no functionality interactions.

Activation/deactivation by the end user

Custom Local Area Signaling Services requires no activation or deactivation by the end user.

Billing

CLASS services, including the Bellcore compliant DSCWID feature, do affect billing. Datafill for table AMAOPTS, when using the CLASS feature DSCWID, is explained in the following examples.

Datafilling table AMAOPTS

The following table shows the datafill specific to the Custom Local Area Signaling Services feature, DSCWID, for table AMAOPTS. Only those fields

Custom Local Area Signaling Services (continued)

that apply directly to Custom Local Area Signaling Services are shown. For a description of the other fields, refer to the *Translation Guide*.

Datafilling table AMAOPTS

Field	Subfield or refinement	Entry	Explanation and action
OPTION	AMAOPT	DSCWID_ CONF_AUDIT	DSCWID conference audit. Key field.
SCHEDULE	AMASEL	PERIODIC	AMA option. Options: OFF, PERIODIC, or DEFAULT. Note: To enable the DSCWID conference audit, AMASEL must be set to PERIODIC, or DEFAULT, where the DEFAULT is PERIODIC.

Datafill example for table AMAOPTS

The following example shows sample datafill for table AMAOPTS.

MAP display example for table AMAOPTS

```

>TABLE AMAOPTS
TABLE: AMAOPTS
>POS DSCWID_CONF_AUDIT
DSCWID_CONF_AUDIT
>CHA
TUPLE TO BE CHANGED:
DSCWID_CONF_AUDIT OFF
ENTER Y TO CONFIRM, N TO REJECT, OR E TO EDIT
>E
AMASEL: OFF
>PERIODIC
ONDATE:
>940915
ONTIME:
>0000
SCHEDULE:
>24 HRS
TUPLE TO BE CHANGED:
DSCWID_CONF_AUDIT PERIODIC 940915 0000 24 HRS
ENTER Y TO CONFIRM, N TO REJECT, OR E TO EDIT
Y

```

Custom Local Area Signaling Services (continued)

Station Message Detail Recording

Custom Local Area Signaling Services does not affect Station Message Detail Recording.

Datafilling office parameters

The following table shows the office parameters used by Custom Local Area Signaling Services. For more information about office parameters, refer to *Office Parameters Reference Manual*.

Office parameters used by Custom Local Area Signaling Services

Table name	Parameter name	Explanation and action
OFCOPT	VSLE_PRESENT	Visual screen list editing. When set to N (no), the ADSI line option must be assigned to the subscriber line in order for visual screen list editing (VSLE) to be accessed. When set to Y, VSLE can be accessed without ADSI being assigned to the line.

Datafill sequence

The following table lists the tables that require datafill to implement Custom Local Area Signaling Services. The tables are listed in the order in which they are to be datafilled.

Datafill tables required for Custom Local Area Signaling Services (Sheet 1 of 2)

Table	Purpose of table
RCCINV	Remote Cluster Controller Inventory. Contains RCC inventory data, except P-side link assignments.
SOFTKEY	Softkey. Specifies softkey information for application services.
TEXTPHRS	Text Phrases. Used by visual screen list editing (VSLE) and other display features.
TEXTLOG	Logical Display Text. Used by VSLE and other display features.
OFCOPT	Office option. Defines office option parameters.
DSCWDTYP	Deluxe Spontaneous Call Waiting Identification (DSCWID) type. Defines DSCWID treatment of subscriber lines.
RESOFC	Residential Office Data. Contains data about features assigned office wide.

Custom Local Area Signaling Services (continued)

Datafill tables required for Custom Local Area Signaling Services (Sheet 2 of 2)

Table	Purpose of table
RESFEAT	Residential Line Feature. Contains assignments of the custom local area signaling services (CLASS) feature for residential lines.
AMAOPTS	AMA options. Controls activation and scheduling of automatic message accounting (AMA).

Datafilling table **RCCINV**

The following table shows the datafill specific to Custom Local Area Signaling Services for table **RCCINV**. Only those fields that apply directly to Custom

Custom Local Area Signaling Services (continued)

Local Area Signaling Services are shown. For a description of the other fields, refer to the *Translation Guide*.

Datafilling table RCCINV (Sheet 1 of 2)

Field	Subfield or refinement	Entry	Explanation and action
OPTCARD		see examples	<p>Optional card. Values: MSGMX76 REM HDLC, MSG6X69 REM DMSX, UTR6, ISP16, and CMR5. If CMR5 is entered, enter the CMR software load name. For DSCWID, CMR firmware must be CMR03A or later. For an RCC2 with extended distance capacity (EDC), MSGMX76 must be datafilled (including protocol) as DMS-X or HDLC. EDC does not support DSCWID. NTMX76 cannot be used as an optional replacement for the NT6X69 card if DSCWID is implemented.</p> <p>Enter MSGMX76 REM HDLC to activate dynamic InSv upgrade from DMS-X to HDLC. Default: MSG6X69 REM DMSX. DMS-X to HDLC dynamic upgrade is not allowed in the inactive CM.</p> <p>Note: Changes to fields with multiple entries should be made in the PROMPT mode only.</p>
	NT7X05AA	NT7X05AA	<p>If NT7X05AA is entered, the system prompts for the slot_number. Slot numbers for the NT7X05AA in RCC2 are 5 and 23, or 7 and 21.</p> <p>Note 1: To support NT7X05 PRL functionality, MX77AA MX77AA is required in field PECS6X45. AX74AA AX74AA in field PECS6X45 does not support NT7X05 PRL functionality.</p> <p>Note 2: If the CMR card is also provisioned, use slot numbers 7 and 21. (Slots 5 and 23 are dedicated to the CMR card.) If the CMR card is not provisioned, use either slots 5 and 23 or 7 and 21.</p>
TONESET		NORTHAA	<p>Tone set. Enter the appropriate tone set for the switch being datafilled. NORTHAA is the North American ADSI-compatible tone set.</p>
<p>Note: When datafilling field C-side link table (CSLNKTAB), assure message links are not assigned to the same physical interface card. When the interface card supports two or more links, separate the message links by the number of links on the interface cards. This applies to all interface link types; DS-1, DS30, DS30A, or PCM-30. Table control will issue a warning if an attempt is made to assign message links on the same interface card. Assigning message links to the same interface card can cause an E1 outage (failure of all message links) if the card fails.</p>			

Custom Local Area Signaling Services (continued)

Datafilling table RCCINV (Sheet 2 of 2)

Field	Subfield or refinement	Entry	Explanation and action
PECS6X45		MX77AA MX77AA or AX74AA, AX74AA	<p>NT6X45 PECs. Enter the two NTMX77 product engineering codes. Enter the PEC for unit 0 first. The PEC must correspond to minimum firmware capabilities among NTMX77s in its processor complex. For example, if the UP is NTMX77AA, enter MX77AA twice.</p> <p>Note: When the NT7X05 PRL is datafilled as an optional card, enter MX77AA MX77AA. AX74AA AX74AA is not allowed as a valid value when the NT7X05 PRL is datafilled as an optional card because the NTAX74 CAP does not support NT7X05 PRL functionality.</p>
E2LOAD		alphanumeric	EEPROM file. Contains the name of the loadfile that is loaded in the NTMX77AA EEPROM or the optional NTAX74AA EEPROM.
<p>Note: When datafilling field C-side link table (CSLNKTAB), assure message links are not assigned to the same physical interface card. When the interface card supports two or more links, separate the message links by the number of links on the interface cards. This applies to all interface link types; DS-1, DS30, DS30A, or PCM-30. Table control will issue a warning if an attempt is made to assign message links on the same interface card. Assigning message links to the same interface card can cause an E1 outage (failure of all message links) if the card fails.</p>			

Datafill example for table RCCINV

The following examples show sample datafills for table RCCINV for both an RCC2 provisioned with the NTMX77AA UP and an RCC2 provisioned with the optional NTAX74AA CAP, respectively.

Custom Local Area Signaling Services (continued)

MAP display example for table RCCINV

Table: RCCINV

RCCNAME	FRTYPE	FRNO	SHPOS	FLOOR	ROW	FRPOS	EQPEC	LOAD
CARY RCC2 0								
1101 CRSC	0	5	0	C	0		MX85AA	CRI08xx
EXECTAB								CONTMARK
(POTS POTSEX) (KEYSET KSETEX) (RMM_TERM RSMEX) (ESALINES ESAEX) \$								
CSPM	CSLNKTAB							CONTMARK
LTC 1	(0)	(1)	(2)	(3)	(4)	(5)	(6)	(7) \$
ESA	INTRASW	OPTCARD		CMRLOAD			CONTMARK	
Y	Y	(UTR6)	(NT7X05AA 7)	(MSG6X69)	(CMR5	CMRAG03)	(ISP16)	\$
TONESET	PECS6X45		E2LOAD		EXTINFO			
NORTHAA	MX77AA	MX77AA	MX77xxxx		CEXT 0 4 0 E 15 MX86AA L			

Note 1: xx in field LOAD stands for alphanumeric text, for example B1.

Note 2: If the shelf is equipped with a processor other than NTMX77, field E2LOAD is automatically datafilled with the value of NILLOAD.

Note 3: NTMX77 UP is required to support NT7X05 functionality. The optional NTAX74 CAP does not support NT7X05 PRL functionality. When a user attempts to datafill field PECS6X45 with AX74AA AX74AA instead of MX77AA MX77AA when NT7X05 is already datafilled as an optional card, the tuple change is disallowed and the MAP displays the following message:

Info: NT7X05AA requires MX77 processor

Note: When field PECS6X45 is datafilled with AX74AA AX74AA instead of MX77AA MX77AA, the load name prefix in field LOAD changes from CRI to XRI. For example, CRI08xx (for MX77) changes to XRI08XX (for AX74AA). The following example shows sample datafill for table RCCINV when the RCC2 is datafilled for the NTAX74AA CAP.

Custom Local Area Signaling Services (continued)

MAP display example for table RCCINV datafilled for NTAX74AA CAP

```

Table: RCCINV
RCCNAME      FRTYPE FRNO SHPOS FLOOR ROW FRPOS  EQPEC  LOAD
-----
CARY RCC2 0
    1101 CRSC  0    5    0    C    0    MX85AA  XRI08xx
EXECTAB
(POTS POTSEX) (KEYSET KSETEX) (RMM_TERM RSMEX) (ESALINES ESAEX) $
CSPM      CSLNKTAB
-----
LTC 1      (0) (1) (2) (3) (4) (5) (6) (7)  $
ESA  INTRASW  OPTCARD      CMRLOAD      CONTMARK
-----
Y    Y          (MSG6X69) (UTR6)(CMR5 CMRAG03) (ISP16)  $
TONESET  PECS6X45  E2LOAD  EXTINFO
-----
NORTHAA  AX74AA  AX74AA  AX74xxxx  CEXT 0 4 0 E 15 MX86AA L
    
```

Datfilling table SOFTKEY

The following table shows the datafill specific to Custom Local Area Signaling Services for table SOFTKEY. Only those fields that apply directly to Custom Local Area Signaling Services are shown. For a description of the other fields, refer to the *Translation Guide*.

Datfilling table SOFTKEY (Sheet 1 of 2)

Field	Subfield or refinement	Entry	Explanation and action
SERVID		0 to 8 characters	Contains the application service identification of the feature for which softkeys will be defined. Vector: 0 to 8 characters.
DEFNUM		2 to 33	Definer number.
LLABEL		0 to 18 characters	Long label string identifier for softkey definer. Vector: 0 to 18 characters.
Note: Changes to fields with multiple entries should be made in the PROMPT mode only.			

Custom Local Area Signaling Services (continued)

Datafilling table SOFTKEY (Sheet 2 of 2)

Field	Subfield or refinement	Entry	Explanation and action
SLABEL		0 to 7 characters	Short label string identifier for softkey definer. Vector: 0 to 7 characters.
RETURN		0 to 14 characters	Return string vector. Vector: 0 to 14. Range: 0 to 255.
Note: Changes to fields with multiple entries should be made in the PROMPT mode only.			

Datafilling table TEXTPHRS

The following table shows the datafill specific to Custom Local Area Signaling Services for table TEXTPHRS. Only those fields that apply directly to Custom Local Area Signaling Services are shown. For a description of the other fields, refer to the *Translation Guide*.

Datafilling table TEXTPHRS

Field	Subfield or refinement	Entry	Explanation and action
PHRSNAME		up to 8 characters	Physical phrase name field, may be up to 8 characters in length.
PHRASE		up to 40 characters	Physical instructional or prompting text string. Vector: up to 40 characters in single quotes. Note: Changes to fields with multiple entries should be made in the PROMPT mode only.
HL_MODE	POSITION	0 to 40	The first subfield POSITION specifies the character position of the change.
	MODE	Normal, Reverse, Grey, or Bold	Subfield MODE.

Datafilling table TEXTLOG

The following table shows the datafill specific to Custom Local Area Signaling Services for table TEXTLOG. Only those fields that apply directly to Custom

Custom Local Area Signaling Services (continued)

Local Area Signaling Services are shown. For a description of the other fields, refer to the *Translation Guide*.

Datafilling table TEXTLOG

Field	Subfield or refinement	Entry	Explanation and action
LPHRSKEY	APPLNAME	VLSE, CALLOG	Three-part key made up of the application name, language, and a display number.
	LANGUAGE	NILANG, LANG1, LANG2	Enter the language used for the display.
	DISPNUM	0 to 127	Enter the numeric index by which the application identifies the display data contained in the tuple.
DISTYPE		see list	Display type character of set Standard (S), Transient (T), Cursor control (C).
LRCI		see list	Display justification indicator field, Center, Right, Left, Indent.
PHRLIST		up to 16	Vector of phrase names from the table TEXTPHRS.
DEFNLIST	SOFTKEY	1 to 33	Vector of softkey definers—Softkey (1 to 33), Mode (N, H), SKT (SRV, CPE).
			Note: Changes to fields with multiple entries should be made in the PROMPT mode only.
	MODE	N, H	
	SKT	SRV, CPE	

Datafilling table DSCWDTYP

The following table shows the datafill specific to Custom Local Area Signaling Services for table DSCWDTYP. Only those fields that apply directly to the

Custom Local Area Signaling Services (continued)

DSCWID feature of Custom Local Area Signaling Services are shown. For a description of the other fields, refer to the *Translation Guide*.

Datafilling table DSCWDTYP (Sheet 1 of 2)

Field	Subfield or refinement	Entry	Explanation and action
NAME		PROPRITY, ADSITIME, ADSICID, NODATA, NOCIDCW, COMPLETE, or others as defined (maximum 8 characters)	DSCWDTYP table key. DSCWID types that can be assigned to subscriber tones. Note: The PROPRITY tuple is fixed to accommodate the proprietary DSCWID feature.
ALERT		SASONLY, SASCAS	Type of tone ALERTING. The CPE receives either SASONLY or SASCAS tones.
CID		NOCID, ALLCID, TIMECID	Caller ID delivery. Type of CID delivered during DSCWID session. Options: no data (NOCID), all data of CID type (ALLCID), and time and date only (TIMECID).
NON ADSI		Y or N	Allow DSCWID features to a non-ADSI sets. When set to N, non-ADSI sets can only signal ANSWER and RETURN. When set to Y non-ADSI sets can signal all options in field KEYOPTS.
<p>Note 1: The operating company cannot change or delete the PROPRITY tuple and can only change (not delete) the other 5 initial tuples.</p> <p>Note 2: ALERT type must be SASCAS to display ADSI complaint features. SASONLY alerting type provides a shorter call waiting function and uses less RCC2 resources for non-ADSI type sets.</p> <p>Note 3: If CID type specified is ALLCID, then a CID feature must be assigned in table RESOFC.</p>			

Custom Local Area Signaling Services (continued)

Datafilling table DSCWDTYP (Sheet 2 of 2)

Field	Subfield or refinement	Entry	Explanation and action
COUNT		0 to 99 999	Line count. The number of lines assigned to this DSCWID type. Note: This field cannot be changed and tuples cannot be deleted from table DSCWDTYP unless the count is 0.
KEY OPTS		ALL, ANSWER, RETURN, FWD, BUSY, HOLD, DROP, CONF, DROPFRST, DROPLAST	Softkey options. A vector of up to 10 softkey options. Enter the specific options allowed on this DSCWID type. If not specified, the option is not available on this DSCWID type. Note: Changes to fields with multiple entries should be made in the PROMPT mode only.
<p>Note 1: The operating company cannot change or delete the PROPRITY tuple and can only change (not delete) the other 5 initial tuples.</p> <p>Note 2: ALERT type must be SASCAS to display ADSI complaint features. SASONLY alerting type provides a shorter call waiting function and uses less RCC2 resources for non-ADSI type sets.</p> <p>Note 3: If CID type specified is ALLCID, then a CID feature must be assigned in table RESOFC.</p>			

Datafill example for table DSCWDTYP

The following example shows sample datafill for table DSCWDTYP.

Custom Local Area Signaling Services (continued)

MAP display example for table DSCWDTYP

Table: DSCWDTYP						
NAME	ALERT	CID	NONADSI	KEYOPTS	COUNT	
PROPRITY	SASCAS	ALLCID	N	ANS RET FWD BUSY HOLD DROP \$	0	
ADSITIME	SASCAS	TIMECID	N	ALL \$	0	
ADSICID	SASCAS	ALLCID	N	ALL \$	0	
NODATA	SASONLY	NOCID	Y	ALL \$	0	
NOCIDCW	SASCAS	TIMECID	Y	ALL \$	0	
COMPLETE	SASCAS	ALLCID	Y	ALL \$	0	

Datafilling table RESOFC

The following table shows the datafill specific to Custom Local Area Signaling Services for table RESOFC. Only those fields that apply directly to Custom Local Area Signaling Services are shown. For a description of the other fields, refer to the *Translation Guide*.

Datafilling table RESOFC (Sheet 1 of 4)

Field	Subfield or refinement	Entry	Explanation and action
KEY		see list of CLASS features	RSCOFC table key. CLASS feature name. Feature must be applied to a line in table RESFEAT to be activated.
ENABLED		Y or N	Feature enabled. When disabled (N), no line can use that CLASS feature.
ACCESS		SUBSCR	Type of access. Values: universal (UNIVER) or subscriber (SUBSCR). DSCWID cannot be assigned to UNVER access.
Note: If CFDA is not available and active and the default treatment assigned is FWD, the RING default is applied to the caller. A warning message stating the reason is displayed at the CC.			

Custom Local Area Signaling Services (continued)

Datafilling table RESOFC (Sheet 2 of 4)

Field	Subfield or refinement	Entry	Explanation and action
FEATNAME		DSCWID	CLASS feature name. DSCWID subfields: DTYPE, DEFTRMT, AMA, BUSYANNC, BUSYSUPV, DFLTANNC, DFLTSUPV, HOLDANNC, HOLDSUPV, REMINDER, TFLASH, TDEFAULT, THOLD, FNLANN.
	DTYPE	PROPRITY, ADSITIME, ADSICID, NODATA, NOCIDCW, COMPLETE	DSCWID type name. Defines DSCWID type name in table DSCWDTYP. Default option: COMPLETE.
FEATNAME (continued)	DEFTRMT	see list	Default treatment. Applied to incoming call when subscriber ignores final call waiting alert. Options: <ul style="list-style-type: none"> • RING (DEF). Allow caller to continue hearing ringing while muting subscriber alert tones. • ANNC. Connect caller to a specified announcement. • FWD. Forward to another line. Subscriber must have the Call Forward Don't Answer (CFDA) feature activated.
	AMA	see list	AMA recording status. For DSWCID, enter NONE or record on use of the conference (CONF) option.
	BUSYANNC	character	Busy announcement. The location name of an announcement in table CLLI to be applied to the calling party if the BUSY option is chosen by the subscriber. Note: If BUSYANNC is not datafilled, or the CLLI code is not effective, the default treatment is disconnect.
	BUSYSUPV	Y or N	Apply BUSY supervision. Determine if answer supervision is applied when first connecting to the BUSY announcement. Default: N.
Note: If CFDA is not available and active and the default treatment assigned is FWD, the RING default is applied to the caller. A warning message stating the reason is displayed at the CC.			

Custom Local Area Signaling Services (continued)

Datafilling table RESOFC (Sheet 3 of 4)

Field	Subfield or refinement	Entry	Explanation and action
	DFLTANNC	character	<p>Default busy announcement. The location name of an announcement in table CLLI to be applied if field DEFTRMT is datafilled with ANNC and the subscriber ignores the final call waiting alert.</p> <p>Note: Can be the same CLLI code as datafilled in BUSYANNC.</p>
FEATNAME (continued)	DFLTSUPV	Y or N	Default supervision. Determine if answer supervision is applied when first connecting to the DFLTANNC announcement. Default: N.
	HOLDANNC	character	HOLD announcement. The location name of an announcement in table CLLI to be applied to the calling party if the HOLD option is chosen by the subscriber.
	HOLDSUPV	see list	HOLD supervision. Determine if answer supervision is applied when connecting to the HOLD announcement. Options: NO, BEFORE, or AFTER. Default: N.
	REMINDER	character	<p>REMINDER announcement. The location name of an announcement in table CLLI to be applied to the calling party when the T-HOLD timer expires.</p> <p>Note: Used to advise caller to stay on the line.</p>
	TFLASH	10 to 80 in increments of 5. 5=.5 sec	<p>T-FLASH timer. Timer to allow non-ADSI customer time to signal the conference option after a flash. Default: 15 (1.5 seconds)</p> <p>Note: Used for the held call state. If the T-FLASH timer expires, the default treatment applied is the RETURN option.</p>
	TDEFAULT	0 to 110 in increments of 5. 5=5 s	T default timer. Time after re-alert before the default treatment is applied to the calling party.
<p>Note: If CFDA is not available and active and the default treatment assigned is FWD, the RING default is applied to the caller. A warning message stating the reason is displayed at the CC.</p>			

Custom Local Area Signaling Services (continued)

Datafilling table RESOFC (Sheet 4 of 4)

Field	Subfield or refinement	Entry	Explanation and action
	THOLD	0 to 12 in increments of 1. 1=10 s	THOLD timer. Time between REMINDER announcements when a call is on hold because the subscriber keyed the HOLD option.
	FNALANN	character	Final announcement. The location name of a treatment in table CLLI to be applied to subscribers without DSCWID option.
<p>Note: If CFDA is not available and active and the default treatment assigned is FWD, the RING default is applied to the caller. A warning message stating the reason is displayed at the CC.</p>			

Datafill example for table |RESOFC

The following example shows sample datafill for table RESOFC. Use table control for manual changes, and SERVORD to apply CLASS features.

Custom Local Area Signaling Services (continued)

MAP display example for table RESOFC

```
TABLE RESOFC:
DSCWID Y SUBSCR DSCWID COMPLETE RING NONE NIL N NIL N NIL
NO NIL 15 15 6 $
>CHANGE
ENABLED: Y
>
ACCESS: SUBSCR
>
FEATNAME: DSCWID
>
DTYPE: COMPLETE
>
DEFTRMT: RING
>
AMA: NONE
>
BUSYANNC: NIL
>
BUSYSUPV: N
>
DFKTANNC: NIL
>
DFLTSUPV: N
>
HOLDANNC: NIL
>
HOLDSUPV: NO
>
REMINDER: NIL
>
TFLASH: 15
>
TDEFAULT: 15
>
THOLD: 6
>
FNALANN:
>$
TUPLE TO BE CHANGED:
DSCWID Y SUBSCR DSCWID COMPLETE RING NONE NIL N NIL N
NIL NO NIL 15 15 6 $
ENTER Y TO CONFIRM, N TO REJECT OR E TO EDIT
```

Custom Local Area Signaling Services (continued)

Datafilling table RESFEAT

The following table shows the datafill specific to Custom Local Area Signaling Services for table RESFEAT. Only those fields that apply directly to Custom Local Area Signaling Services are shown. For a description of the other fields, refer to the *Translation Guide*.

Note 1: A tuple cannot be added to table RESFEAT until the line to which it is being assigned has been datafilled in table IBNLINES.

Note 2: Datafill for DSCWID options, previously in table IBNLINES, is moved to the RESFEAT table.

SERVORD is the recommended way to assign DSCWID to a subscriber's line. However, RESFEAT table control does allow DSCWID to be added to a subscriber line.

Datafilling table RESFEAT (Sheet 1 of 2)

Field	Subfield or refinement	Entry	Explanation and action
LINE		number	Line equipment number. External LEN number assigned to a line. This is the first part of the key field for table RESFEAT.
KEY		0 to 69	Business set key number. Second part of key field of table RESFEAT. Number designating the key a feature is to be assigned. Must always be set to 0 for DSCWID features.
FEAT		DSCWID	CLASS feature name. Third part of key field of table RESFEAT. Feature to be assigned. Examples: DSCWID, CND, CNDB, ADSI, CID
VAR		see subfields	Feature variable area. Modified variable area, defined for each feature. See the following subfields.
	DF	DSCWID	CLASS feature name. DSCWID subfields: AMA, STATUS, DTYPE, DEFTRMT, DAMA, CONFPEGS.
	AMA	NOAMA, AMA	CLASS AMA status. AMA status is not used for DSCWID.
	STATUS	ACT, INACT, UNIVI, UNIVA	CLASS activity status. For DSCWID, use ACT.

Custom Local Area Signaling Services (continued)

Datafilling table RESFEAT (Sheet 2 of 2)

Field	Subfield or refinement	Entry	Explanation and action
VAR (continued)	DF	ADSI, SCRJ, SCF, SCA, DSCWID, DRCW, DDN, CND, or CNAMD	CLASS feature name.
	DTYPE	PROPRITY, ADSITIME, ADSICID, NODATA, NOCIDCW, COMPLETE, DEF	DSCWID type. Key of NAME field in table DSCWDTYP, plus the value of DEF in field DTYPE of table RESOFC. Note: The PROPRITY value is included for compatibility of existing proprietary CPEs. This value is blocked when adding or changing options on a line.
	DEFTRMT	RNG, FWD, ANNC, or DEF	Default treatment. When no DSCWID option is chosen by subscriber.
DAMA		NONE, CONF, or DEF	AMA recording status type.
CONFPEGS		0 to 32767	AMA conference pegs. The number of successful DSCWID conference attempts made if the datafill in field DAMA is CONF.

Translation verification tools

Custom Local Area Signaling Services does not use translation verification tools.

SERVORD

To add option DSCWID to a line, use SERVORD commands NEW (establish service), ADO (add option), and ADD (add line to a hunt group). To delete option DSCWID from a line, use commands DEO (delete option), DEL (delete line from a hunt group), and OUT (remove service). To convert lines with the proprietary type of DSCWID to TR-compliant DSCWID, use the CHF (change feature) command.

Custom Local Area Signaling Services (continued)

If CWT is not assigned to a line when DSCWID is added, CWT is added automatically. The CWT feature is also removed automatically when the DSCWID feature is deleted.

Note: When the value DEF is used for subfields DTYPE, DAMA, and DEFTRMT in table RESFEAT, SERVORD uses the same datafill as the related subfields defined in table RESOFC (DTYPE, AMA, and DEFTRMT).

SERVORD limitations and restrictions

The following SERVORD limitations and restrictions apply to Custom Local Area Signaling Services:

- Operating company personnel cannot assign DSCWID to a line using the PROPRITY DSCWID type. The PROPRITY type represents the proprietary version of DSCWID used before the TR-compliant DSCWID became available. The PROPRITY type is blocked from being used during the ADO and CHF commands.
- If DSCWID is assigned to a line that already has SCWID, DSCWID replaces SCWID. By allowing the replacement, fewer commands are required to add DSCWID to a line that already has SCWID.
- If DSCWID is assigned to a line that already has Call Waiting (CWT), DSCWID supercedes CWT. CWT still exists on the line, since DSCWID is built on top of CWT. CWT appears as an option when the line is queried with a QDN (query directory number) or QLEN (query line equipment number) command.
- A line does not require a CID feature to have DSCWID assigned. However, to assign DSCWID with ALLCID (all calling identification data) as the CID off-hook delivery type in table DSCWD TYP, either CND, DDN, or CNAMD must be assigned to the line. With the values NOCID or TIME for the CID off-hook delivery type, no CID feature is required.
- The Call Waiting Intragroup (CWI) feature is added or deleted separately from DSCWID on MDC lines. On a line that contains DSCWID, CWT, and CWI or Call Waiting Ringback (CWR), CWT cannot be deleted without removing CWI or CWR first.
- DSCWID cannot be added to a line with Feature Groups assigned.
- DSCWID cannot be assigned to a line having an LCC of PSET.

Custom Local Area Signaling Services (continued)

SERVORD prompts

The following table shows the SERVORD prompts used to assign Custom Local Area Signaling Services to a line.

SERVORD prompts for Custom Local Area Signaling Services

Prompt	Valid input	Explanation
SONUMBER	alphanumeric	The unique number of the service order
DN_OR_LEN	numeric	The DSCWID line's DN or LEN
OPTION	DSCWID	The feature to be added, modified, or deleted
DSUBOPT	DTYPE, DAMA, DEFTRMT	The DSCWID suboption to be assigned. This is a vector of up to three suboptions. If no suboptions are entered, default values are used. The vector is terminated with a \$.
		Note: Changes to fields with multiple entries should be made in the PROMPT mode only.
DTYPEOPT	ADSITIME, ADSICID, NODATA, NOCIDCW, COMPLETE	The DSCWID type name that indicates which DSCWID type to assign from table DSCWDTYP. Additional values are possible if tuples are datafilled in table DSCWDTYP.
DEFTRMTOPT	RING, FWD, ANNC	The default treatment to be applied when no DSCWID option is chosen.
DAMAOPT	NONE, CONF	The type of AMA recording status for use with the CONFERENCE option. Enter NONE for no recording, or CONF to generate an AMA billing record.

SERVORD example for implementing Custom Local Area Signaling Services

The following SERVORD example shows how Custom Local Area Signaling Services is added to an existing line using the ADO command. The line does not have SCWID or CWT assigned, and the following parameters were datafilled in table RESOFC prior to each SERVORD command:

- The default DSCWID type is set to ADSITIME.
- The default DSCWID conference AMA status is set to NONE.
- The default DSCWID default treatment is set to FWD.

Custom Local Area Signaling Services (continued)

SERVORD example for Custom Local Area Signaling Services in prompt mode

```
>SERVORD
SO:
>ADO
SONUMBER:  NOW 89 10 04 AM
>
DN_OR_LEN:
>6215000
OPTION:
>DSCWID
DSUBOPT:
>$
OPTION:
>$
COMMAND AS ENTERED:
ADO NOW 89 10 04 AM 6215000 (DSCWID) $ $
ENTER Y TO CONFIRM, N TO REJECT OR E TO EDIT
>Y
```

SERVORD example for Custom Local Area Signaling Services in non-prompt mode

```
>ADO $ 6215000 DSCWID $ $ Y
```

SERVORD example for overriding the default DSCWID type

The following SERVORD example shows how DSCWID is added to an existing DSCWID line with the default type of ADSITIME. The default type is changed to ADSICID, thus overriding the default DSCWID type defined in table RESOFC.

Custom Local Area Signaling Services (continued)

SERVORD example for overriding the default DSCWID type in prompt mode

```

>SERVORD
SO:
>CHF
SONUMBER:  NOW 89 10 04 AM
>
DN_OR_LEN:
>6215000
OPTION:
>DSCWID
DSUBOPT:
>DTYPE
DTYPEOPT:
>ADSID
DSUBOPT:
>$
OPTION:
>$
COMMAND AS ENTERED:
CHF NOW 89 10 04 AM 6215000 (DSCWID) (DTYPE ADSICID) $ $
ENTER Y TO CONFIRM, N TO REJECT OR E TO EDIT
> Y

```

SERVORD example for overriding the default DSCWID type in non-prompt mode

```

>CHF $ 6215000 DSCWID DTYPE ADSICID $ $ Y

```

SERVORD example for overriding all possible parameters

The following SERVORD example shows how DSCWID is added to an existing DSCWID line with parameters already set in table RESOFC. All parameters have been changed with the CHF command.

Custom Local Area Signaling Services (end)

SERVORD example for overriding all possible parameters in prompt mode

```
>SERVORD
SO:
>CHF
SONUMBER:  NOW 89 10 04 AM
>
DN_OR_LEN:
> 6215000
OPTION:
>DSCWID
DSUBOPT:
>DTYPE
DTYPEOPT:
>ADSICID
DSUBOPT:
>DAMA
DAMAOPT:
>CONF
DSUBOPT:
>DEFTRMT:
DEFTRMTOPT:
>ANNC
OPTION:
> $
COMMAND AS ENTERED:
CHF NOW 89 10 04 AM 6215000 (DSCWID) (DTYPE ADSICID)
(DAMA NONE) (DEFTRMT ANNC) $
ENTER Y TO CONFIRM, N TO REJECT OR E TO EDIT
> Y
```

SERVORD example for overriding all possible parameters in non-prompt mode

```
>CHF $ 6215000 DSCWID DTYPE ADSICID DAMA CONF DEFTRMT
ANNC $ Y
```

Trunks

Functional group

BAS00012

Feature package

NTX152AB RSC Trunking

Release applicability

BCS19 and later versions

Requirements

Trunks requires the following feature packages:

- NTX000AA Bilge
- NTX001AA Common Basic
- NTX145AA Remote Switching Center
- NTX269AA Universal Tone Receivers (Domestic)
- NTX270AA New Peripheral Maintenance

Description

The RSC-S dynamic trunk capability is assigned for each trunk group. Table ISTRKGRP is created for this purpose. Table ITRKGRP contains the common language location identifiers (CLLI) of the trunk groups with dynamic trunk members. The table contains the name of the site and the enhanced remote cluster controller 2 (RCC2) that limits the trunk group.

You must enter data in table ISTRKGRP if dynamic trunking is to be supported at the RSC-S.

Table ISTRKGRP provides trunk group extension data. If you enter subgroups of the trunk group in table TRKSGRP, changes, additions, or deletions to table ISTRKGRP are not permitted. Changes are not permitted to table ISTRKGRP if you enter members of the trunk group in table TRKMEM.

Intraswitching capability is provided on a trunk group basis. Trunk groups must be different by site, and trunk members of that group must belong to that specified site. The DMS switch cannot distinguish from trunks in the same group at different sites. Dynamic trunks must be members of a trunk group different to one RCC2. Table control enforces this condition.

Trunks (continued)

How channels are configured for each trunk type

When you add network-only trunks, table control assigns central-side (C-side) channels for each network-only trunk evenly across equipped links on an RCC2. This process reduces the number of trunks that go out of service if a link is lost. When you add dynamic trunks, the RCC2 does not allocate C-side channels.

Adding or deleting C-side links

Table control does not allow you to delete a C-side or a P-side link if network-only trunks use channels on that link. Table control gives a list of the failed trunk members. You must delete these trunk members from table TRKMEM. You can add these trunk members again after the C-side links are configured again.

Adding network trunks

To add network trunks to the P-side of an RCC2, you must perform these steps:

- Enter table CLLI.
- Enter table TRKGRP.
- Enter table TRKSGRP.
- Add the trunk members to table TRKMEM.

Adding dynamic trunks

To add dynamic trunks to the P-side of an RCC2, you must perform the following steps:

- Enter table CLLI.
- Enter table TRKGRP.
- Enter table ISTRKGRP.
- Enter table TRKSGRP.
- Add the trunk members to table TRKMEM.

Errors

Entries in these tables can fail for the following reasons:

- Additions to table TRKMEM or table TRKSGRP can fail if an entry is present in table ISTRKGRP.
- Additions to table TRKSGRP fail if the trunk subgroup has an echo suppressor or the trunk is an FX trunk. The FX trunks are not allowed on dynamic trunk groups because they are not supported by the universal tone receiver (UTR).

Trunks (continued)

- An entry in table TRKMEM can fail if the following condition occurs. The trunk entered in table TRKMEM is not on the RCC2 entered in table ISTRKGRP against the trunk group to which that trunk belongs. When this happens, the following message appears at the MAP terminal.

```
BAD DYNAMIC TRUNK LOCATION, CHECK ISTRKGRP
```

- Another failure can result when no intraswitch channels are available for the dynamic trunks. An error message appears that signifies that intraswitched channels are assigned.

Changing a network trunk to a dynamic trunk

To change a network-only trunk on an RCC2 to a dynamic trunk, you must perform five steps:

- delete all group members from table TRKMEM
- delete correct trunk subgroups from table TRKSGRP
- add the member entry to table ISTRKGRP
- add the trunk subgroups to table TRKSGRP
- add the group members to table TRKMEM

Note: Before you delete information from the tables, the affected trunk must be installation busy. After you add the required information, return the trunk to service.

Datafill sequence to change a dynamic trunk to a network trunk

To change a dynamic trunk on an RCC2 to a network-only trunk, perform the following steps:

- delete all group members from table TRKMEM
- delete correct trunk subgroups from table TRKSGRP
- delete the member entry from table ISTRKGRP
- add the trunk subgroups to table TRKSGRP
- add the group members to table TRKMEM

Note: Before you delete information from the tables, the affected trunk must be installation busy. After you add the required information, return the trunk to service.

Trunks (continued)

Operation

Does not apply

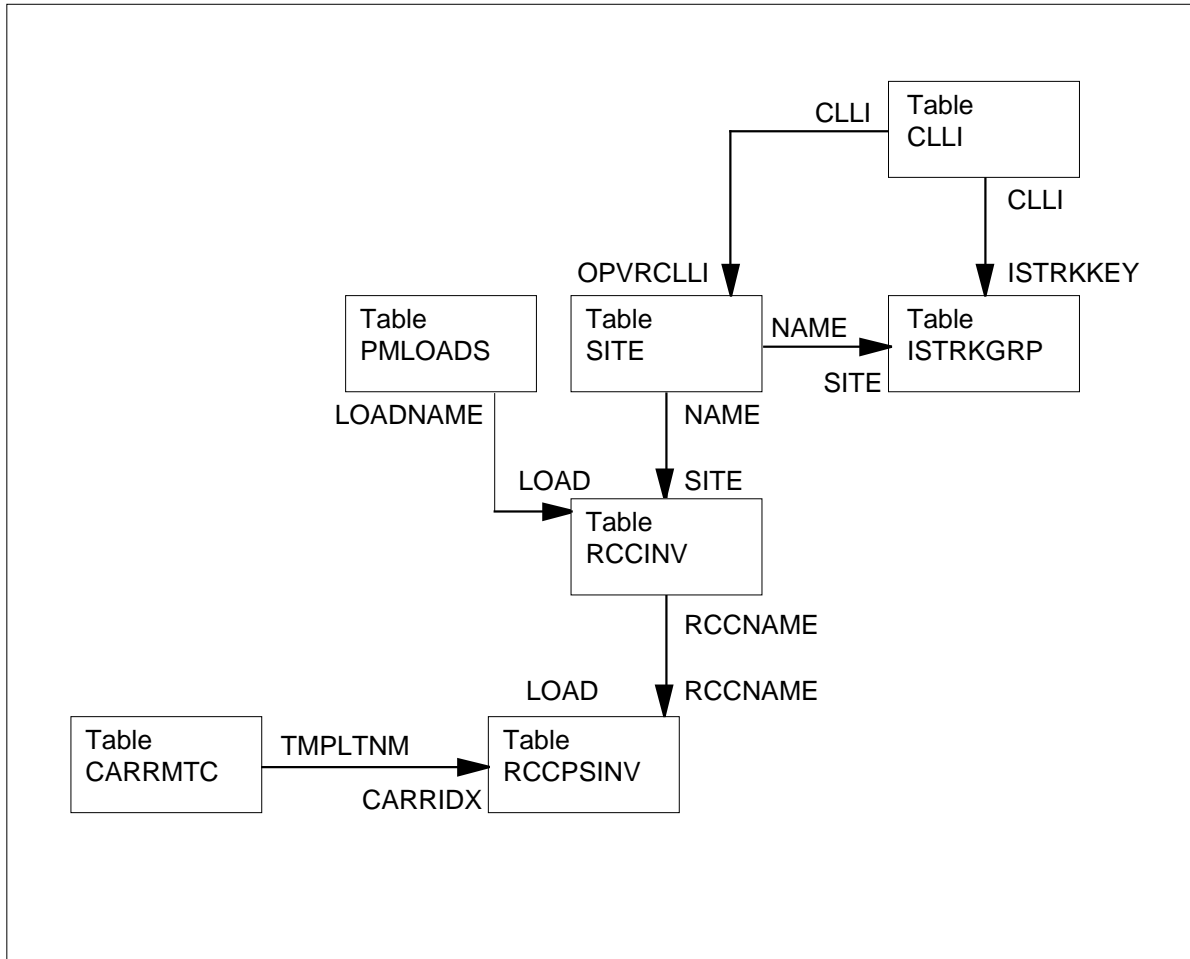
Translations table flow

The Trunks translations tables appear in the following list:

- Table ISTRKGRP controls the dynamic nature of the trunks located on an RCC2. An entry in this table indicates that a trunk group has dynamic capability. Subfield SITE_ID in table ISTRKGRP corresponds to the NAME tuple from table SITE. This condition identifies the equipment for the switching unit and for all remote locations that home on to the equipment. Field ISTRKKEY in table ISTRKGRP corresponds to the CLLI tuple from table CLLI. This condition identifies the trunk group to assign dynamic capability.
- Table RCCPSINV contains only the P-side link assignments for the RCC2. When you add a tuple in table RCCINV, the system adds a corresponding tuple in table RCCPSINV. The CARRIDX field indexes into table CARRMTC for maintenance control information about peripheral. The RCCNAME tuple in table RCCPSINV corresponds to the RCCNAME tuple from table RCCINV. The tuple stores site information, first entered in the NAME field from table SITE, the PM type, and PM number.
- Table RCCINV maintains a list of RCC2s entered in the DMS system and contains inventory data for the RCC2s. Table RCCINV does not contain P-side link assignments. The table information identifies where the RCC2 is, the load and exec lineups required, and the network link connections. Enter C-side DS-1 assignments for the RCC2 in table RCCINV. Enter intraswitching in table RCCINV.

Enter load information for this table in field LOAD. Load information corresponds to tuple LOADNAME from table PMLOADS. Tuple RCCNAME in table RCCINV corresponds to tuple RCCNAME from table RCCPSINV. Field RCCNAME stores site information, first entered in the NAME field from table SITE, the PM type, and PM number.

The Trunks translation process appears in the following flowchart.

Trunks (continued)**Table flow for Trunks****Limits**

The following limits apply to Trunks:

- Enter data in table PMLOADS with peripheral module (PM) load information before you can enter table RCCINV.
- The SITE entry must correspond to an entry in table SITE.
- Before you enter table ISTRKGRP, table TRKGRP must know of the CLLI of the dynamic trunk group. Table TRKSGRP and table TRKMEM must not know of the CLLI of the dynamic trunk group.
- You cannot change, add, or delete a trunk group in table ISTRKGRP if you enter subgroups of the trunk group in table TRKGRP. You also cannot change, add, or delete a trunk group if you enter members of the trunk group in table TRKMEM.

Trunks (continued)

Interactions

Trunks does not have functionality interactions.

Activation/deactivation by the end user

Trunks does not require activation or deactivation by the end user.

Billing

Trunks does not affect billing.

Station Message Detail Recording

Trunks does not affect Station Message Detail Recording.

Datafilling office parameters

Trunks does not affect office parameters.

Datafill sequence

The tables that require datafill to implement Trunks appear in the following table. The tables appear in the correct entry order.

Datafill requirements for Trunks

Table	Purpose of table
RCCINV	Remote Cluster Controller Inventory. Maintains a list of RCC2s entered in the DMS. The table information identifies where the RCC2 appears, the load and exec lineups required, and the network link connections.
RCCPSINV	Remote Cluster Controller P-side Link Inventory. Contains only P-side link assignments for the RCC2.
ISTRKGRP	RCC Dynamic Trunk Groups. Controls the dynamic nature of trunks on an RCC2. An entry in this table indicates that a trunk group has dynamic capability.

Datafilling table RCCINV

Table Remote Cluster Controller Inventory (RCCINV) contains inventory data, except P-side link assignments, for the RCC2. Enter C-side digital signal 1 (DS-1) assignments for the RCC2 in table RCCINV. This table controls intraswitched calls for dynamic trunks.

Trunks (continued)

Datafill for Trunks for table RCCINV appears in the following table. Only the fields that apply to Trunks appear in this table. See the *Translation Guide* for a description of the other fields.

Datafilling table RCCINV

Field	Subfield or refinement	Entry	Explanation and action
INTRASW		Y	Intraswitching. Use this boolean field to control intraswitched calls for the specified peripheral. Entry values: Y (if intraswitching on the RCC2 is allowed), or N (if intraswitching is not allowed).
Note: When you enter field C-side link table (CSLNKTAB), assure message links are not assigned to the same physical interface card. When the interface card supports two or more links, separate the message links by the number of links on the interface cards. This condition applies to interface link types: DS-1, DS30, DS30A, or PCM-30. Table control issues a warning if an attempt is made to assign message links on the same interface card. To assign message links to the same interface card can cause an E1 outage if the card fails. An E1 outage is the failure of all message links.			

Datafill example for table RCCINV

Sample datafill for the Trunks in table RCCINV appears in the following example. The sample data is for an RCC2 provisioned with the NTMX77AA UP and an RCC2 provisioned with the optional NTAX74AA CA, in the order given.

Trunks (continued)

MAP example for table RCCINV entered for NTMX77AA UP

```

Table: RCCINV
RCCNAME      FRTYPE FRNO SHPOS FLOOR ROW FRPOS   EQPEC   LOAD
-----
CARY RCC2 0  CRSC   0  18   0   C   0   MX85AA  CRI08xx

EXECTAB
(POTS POTSEX)(KEYSET KSETEX)(ABTRK DTCEX)(RMM_TERM RSMEX)
(ESALINES ESAEX)                                     $

CSPM          CSLNKTAB
-----
PLGC 1      (0) (1) (2) (3) (4) (5) (6) (7)                                     $

ESA  INTRASW  OPTCARD                                     CMRLOAD
-----
N    Y          (UTR6)(MSG6X69) | (NT7X05AA 7) | (CMR18 CMRAG03) $
TONESET PECS6X45      E2LOAD      EXTINFO
-----
NORTHAM  MX77AA  MX77AA  MX77xxxx  CEXT 0 4 0 E 15 MX86AA L
    
```

Note 1: xx in field LOAD and xxxx in field E2LOAD represent alphanumeric entries, for example B1 and XE01, in the order given.

Note 2: If the shelf has a processor other than NTMX77 or the optional NTAX74, the system automatically enters field E2LOAD with value NILLOAD.

Note 3: The NTMX77 UP supports NT7X05 functionality. The optional NTAX74 CAP does not support NT7X05 PRL functionality. The MAP displays a message when a user attempts to enter field PECS6X45 with AX74AA AX74AA instead of MX77AA MX77AA. The user attempts this entry when NT7X05 is already entered as an optional card. The tuple change is not allowed and the following message appears:

Info: NT7X05AA requires MX77 processor

Note 4: When you enter AX74AA AX74AA in field PECS6X45 instead of MX77AA MX77AA, the load name prefix in field LOAD changes from CRI to XRI. For example, CRI08xx (for MX77) changes to XRI08XX (for AX74AA). The following example shows sample datafill for table RCCINV when the user enters RCC2 for the NTAX74AA CAP.

Trunks (continued)**MAP example for table RCCINV entered for NTAX74AA CAP**

Table: RCCINV

RCCNAME	FRTYPE	FRNO	SHPOS	FLOOR	ROW	FRPOS	EQPEC	LOAD	
CARY RCC2 0	CRSC	0	18	0	C	0	MX85AA	XRI08xx	
EXECTAB									
(POTS POTSEX) (KEYSET KSETEX) (ABTRK DTCEX) (RMM_TERM RSMEX)								\$	
(ESALINES ESAEX)									
CSPM CSLNKTAB									
LTC 1	(0)	(1)	(2)	(3)	(4)	(5)	(6)	(7)	
\$									
ESA	INTRASW	OPTCARD					CMRLOAD		
N	Y	(UTR6)	(MSG6X69)					(CMR18 CMRAG03)	\$
TONESET	PECS6X45	E2LOAD	EXTINFO						
NORTHAM	AX74AA	AX74AA	AX74xxxx	CEXT 0 4 0 E 15 MX86AA L					

Datafilling table RCCPSINV

Table Remote Cluster Controller P-side link Inventory (RCCPSINV) contains only the P-side link assignments for the RCC2. You can enter a maximum of 54 (0-53) multiples of P-side link information for the RCC2.

Trunks (continued)

Datafill for Trunks for table RCCPSINV appears in the following table. Only fields that apply to Trunks appear in this table. See the *Translation Guide* for a description of the other fields.

Datafilling table RCCPSINV (Sheet 1 of 2)

Field	Subfield or refinement	Entry	Explanation and action
PSLNKTAB		refer to subfields	P-side link table. This field is a vector. Subfields: PSLINK, and PSDATA. Refer to Note 1 for information on how to enter data. Refer to Note 2 for information about terminating data entry.
	PSLINK	0 to 53	P-side link. Enter the P-side port number.
	PSDATA	refer to subfields	P-side data. Subfield refinements: AREASELECT. Refer to Note 2 for information about terminating data entry.
	AREASELECT	DS1, DS30A, NILTYPE	Area selector. Entry values. Enter DS1 for links to remotes of a remote and for RCC, RCC2, and SRCC and datafill refinements CARRIDX and ACTION. Enter DS30A for all links to remote maintenance modules (RMM) and line concentrating modules (LCM); or NILTYPE for unequipped links. D-channel handlers (DCH) on an RCC2 must reside on odd ports.
<p>Note 1: Make changes to fields with multiple entries in the PROMPT mode only. In nonprompt mode you can omit current entries.</p> <p>Note 2: Enter the continuation mark (+) in fields with multiple possible entries when you specify more data on the next line or you enter more records. Enter the end mark (\$) in fields with multiple possible entries after the last entry.</p> <p>Note 3: You must enter both CARRIDX and ACTION after you enter DS-1 for AREASELECT.</p>			

Trunks (continued)**Datafilling table RCCPSINV (Sheet 2 of 2)**

Field	Subfield or refinement	Entry	Explanation and action
	CARRIDX	alphanumeric (a maximum 16 characters), DEFAULT	Carrier index. If the entry in subfield AREASELECT is D30 or DS1, enter data in this refinement. Enter the name to index into table CARRMTC for maintenance information on the carrier. Enter DEFAULT for the default template in table CARRMTC.
	ACTION	Y or N	Action. If the entry in subfield AREASELECT is D30 or DS1, enter data in this refinement. Enter Y (yes) if the carrier must be removed from service when the out-of-service limit (OL) for frame, slip, errored-second, or severe errored-second is exceeded. If this action does not occur, enter N (no).
<p>Note 1: Make changes to fields with multiple entries in the PROMPT mode only. In nonprompt mode you can omit current entries.</p> <p>Note 2: Enter the continuation mark (+) in fields with multiple possible entries when you specify more data on the next line or you enter more records. Enter the end mark (\$) in fields with multiple possible entries after the last entry.</p> <p>Note 3: You must enter both CARRIDX and ACTION after you enter DS-1 for AREASELECT.</p>			

Datafill example for table RCCPSINV

Sample datafill for table RCCPSINV appears in the following example.

Trunks (continued)

MAP example for table RCCPSINV

```

Table: RCCPSINV

RCCNAME                                PSLNKTAB
-----
CARY RCC2 0    (0 DS-1 DEFAULT N) (1 DS-1 DEFAULT N)
(2 DS-1 DEFAULT N) (3 DS-1 DEFAULT N)
(4 DS-1 DEFAULT N) (5 DS-1 DEFAULT N)
(6 DS-1 DEFAULT N) (7 DS-1 DEFAULT N)
(8 NILTYPE) (9 NILTYPE) (10 NILTYPE)
(11 NILTYPE)
...
...
(21 NILTYPE) (22 NILTYPE) (23 NILTYPE)
(24 NILTYPE) (25 NILTYPE) (26 NILTYPE)
(27 NILTYPE) (28 NILTYPE) (29 NILTYPE)
...
...
(44 NILTYPE) (45 NILTYPE) (46 NILTYPE)
(47 NILTYPE) (48 NILTYPE) (49 NILTYPE)
(50 NILTYPE) (51 NILTYPE) (52 NILTYPE)
(53 NILTYPE)                                $
    
```

Error messages for table RCCPSINV

The following error messages apply to table RCCPSINV.

Error messages for table RCCPSINV

Error message	Explanation and action
Failed to allocate pslinks tables	Cannot allocate temporary store for P-side tables.
Cannot datafill &\$ in link &\$	P-side link restrictions for RCC2 prevent datafill. For example, if the first parameter is the link type entered while the second parameter is the link number.
DS-1 not allowed on link &\$ when DCH datafilled on link &\$	P-side link limits for RCC2 prevent datafill.
Only 20 pside links are allowed	Attempted to datafill more than 20 P-side links on the RCC.

Trunks (continued)**Datafilling table ISTRKGRP**

Table ISTRKGRP (RCC Dynamic Trunk Groups Table Record) maintains records of trunk groups with dynamic capability. To maintain records, table ITRKGRP associates the dynamic trunks with the CLLI and the RCC2 table ISTRKGRP is limited to. Failure to provide datafill for this table can cause in a traffic overload in the RSC-S. This condition occurs unless sufficient host-to-remote links support the remote P-side trunk links on a one-to-one ratio.

Datafill for Trunks for table ISTRKGRP appear in the following table. Only fields that apply to Trunks appear in this table. See the *Translation Guide* for a description of the other fields.

Datafilling table ISTRKGRP (Sheet 1 of 2)

Field	Subfield or refinement	Entry	Explanation and action
ISTRKKEY		alphanumeric (1 to 16 characters)	Dynamic trunk group CLLI. Enter the CLLI of the dynamic trunk group. The CLLI entered here must appear in table TRKGRP and must not appear in tables TRKSGRP and TRKMEM. The trunk group must be one of the following types: <ul style="list-style-type: none"> • incoming end office (TI) • outgoing end office (TO) • two-way end office (T2) • integrated business network (IBN) incoming (IBNTI) • IBN outgoing (IBNTO) • IBN two-way (IBNT2) • two-way private branch exchange (PBX) digital (PX)
XPMNAME		refer to subfields	Peripheral name. Subfields: SITE_ID, PMT, and EXT_PMNO.
	SITE_ID	alphanumeric (a maximum of 4 characters)	Site. Enter the RSC-S site. Table SITE (field NAME) must know this site.

Trunks (end)**Datafilling table ISTRKGRP (Sheet 2 of 2)**

Field	Subfield or refinement	Entry	Explanation and action
	PMT	RCC2	Peripheral module type. Enter RCC2.
	EXT_PMNO	0-127	Peripheral module number. Enter RCC2 PM number associated with the trunk group.

Datafill example for table ISTRKGRP

Sample datafill for table ISTRKGRP appears in the following example.

MAP example for table ISTRKGRP

Table: ISTRKGRP				
ISTRKKEY			XPMNAME	

RSTOP	CARY	RCC2	0	
RSTIP	CARY	RCC2	0	
RSCIBN2WP	CARY	RCC2	0	
RSCIBNTOP	CARY	RCC2	0	
RSCIBNTIP	CARY	RCC2	0	
RSCPX2WP	CARY	RCC2	0	
RSTASEAS1WO	CARY	RCC2	0	
RSTASEAS1WI	CARY	RCC2	0	
RSTASEAS2W	CARY	RCC2	0	
RSTASIBN1WO	CARY	RCC2	0	
RSTASIBN2W	CARY	RCC2	0	
RSTASPX2W	CARY	RCC2	0	

Tools for verifying translations

Trunks does not use tools to verify translations

SERVORD

Trunks does not use SERVORD.

ESA Lines

Functional group

BAS00012

Feature package

NTX149AA RSC ESA Operations—Lines

Release applicability

BCS20 and higher

Requirements

ESA Lines require the following feature packages:

- NTX000AA Bilge
- NTX001AA Common Basic
- NTX145AA Remote Switching Center
- NTX270AA New Peripheral Maintenance Package
- NTX901AA Local Features I

Note: The system removes feature packages NTX150AA and NTXP92AA as required packages for feature package NTX149AA.

Description

The improved remote cluster controller 2 (RCC2) must contain software that provides the emergency stand-alone (ESA) software. The software is for the ESA lines for the remote switching center-SONET (RSC-S). Tables required for implementing the ESA lines feature package include tables RCCINV, ESAPXLA and CUSTHEAD. Office parameters that associate with ESA lines that control ESA entry and exit also control the ESA static data download.

Table RCCINV

The Remote Cluster Controller Inventory (RCCINV) table contains all of the the inventory data for the RCC2, except the peripheral side (P-side) link assignments. The following datafill is necessary in table RCCINV for the ESA application:

- Field TRMTYPE in table RCCINV must be datafilled with the entry ESALINES.
- Field EXEC in table RCCINV must be datafilled with the entry ESAEX.
- Field ESA in table RCCINV is a boolean and must be set to Y(yes) if the RSC-S has ESA.

ESA Lines (continued)

The ESA flag (field ESA) allows operating company personnel to turn the ESA option on or off. A change in the ESA flag appears immediately at the DMS central control (CC). The change indication only transfers to the RCC2 during the next update of the static data. The RCC2 must be made busy (BSY) and returned to service (RTS) immediately after the status of the ESA flag is changed.

A warning appears on the MAP (maintenance and administration position) display when the flag changes. The warning indicates that an update of the RCC2 static data or the ESA static data is required. In addition, the RCC2 is marked in-service trouble (ISTb) with either STATIC DATA or ESA STATIC DATA designated as the reason.

Perform the procedures to change the ESA flag in the following order:

1. Change the ESA field in table RCCINV to the required setting.
2. Manually BSY and RTS the inactive RCC2 unit.
3. SWACT the RCC2.

Table ESAPXLA

The Emergency Stand-Alone Prefix Translation (ESAPXLA) table contains special prefix translation data. The data is for plain ordinary telephone system (POTS) and Integrated Business Network (IBN) customer groups. This table is not used during normal operation of the RCC2 or RLCM. Translations are performed in the central control (CC). If communication with the host is lost and the RCC2 or RLCM enters ESA mode, then this the ESAPXLA table is used in the prefix translations.

Table CUSTHEAD

Table Customer Header (CUSTHEAD) links a customer group to the prefix translation table name as identified in table ESAPXLA.

Link the information in the ESAPXLA prefix tables to a particular customer group for IBN lines. An option called ESAPXLA specifies the prefix translator name associated with the customer group.

If the ESA feature package is present, datafill fields OPTION and XLANAME of table CUSTHEAD. The system does not provide prefix translations for the customer group if the OPTION field does not have the ESAPXLA.

ESA Lines (continued)

Office parameters associated with ESA lines

The office parameters associated with ESA entry and exit include:

- RSC_ESA_NOTIFY_TONE
- RSC_XPMESAEXIT

The RSC-ESA Lines feature package uses office parameters that control ESA static data. The required office parameters that appear in a switching unit with the NTX149AA software feature package, are:

- RSC_ESASDUPD_BOOL
- RSC_ESASDUPD_HOUR

Note: The *Office Parameters Reference Manual* describes all office parameters.

RSC_ESA_NOTIFY_TONE

This parameter controls the dial-tone burst (0.25 s on, 0.25 s off) the subscriber hears to alert the end user that the RCC2 is in ESA. The parameter resides in table OFCENG.

RSC_XPMESAEXIT

The time-out RSC_XPMESAEXIT is used in ESA-EXIT to protect against bouncing links. This parameter is the exit delay parameter. The parameter allows time for a bad link to become stable after the link recovers.

During an RSC_XPMESAEXIT time-out, the RCC2 continues in ESA mode. The CC communicates with the ESA unit every 10 s to determine if links to the RCC2 continue to operate. If communications fail again during the RSC_XPMESAEXIT time-out, the CC does not proceed with the ESA-EXIT. If the RSC_XPMESAEXIT parameter is set to zero (default value), you must manually intervene during the ESA-EXIT.

The RSC_XPMESAEXIT office parameter specifies the ESA-EXIT delay time. A manual exit is necessary if the RSC_XPMESAEXIT office parameter is set to zero, or the SYSTEM_ESA_EXIT field is set to "N", or when the RCC2 unit is ManB.

ESA Lines (continued)

The following table describes the fields for office parameter RSC_XPMESAEXIT and has an example for each field.

Fields for RSC-S_XPMESAEXIT

Field	Example
Name	RSC_XPMESAEXIT
Type	EXIT_DELAY_TYPE
SYSTEM_ESA_EXIT	{N, Y}
Default	6 (60)
Minimum value	0 (0 s)
Maximum value	100 (1000 s)

During the exit time-out period, the time-out status displays the time-out count down at the MAP terminal. For example, when approximately ten s are left in the time-out period, the following message appears: ESA T.O. 10. The time-out status is updated every ten s.

During ESA exit, a message appears at the MAP terminal to indicate that the RCC2 exits ESA.

RSC_ESASDUPD_BOOL

The RSC_ESASDUPD_BOOL office parameter specifies if static data updates should be scheduled each night. If the value is left at the default value of Y, the static data is downloaded during the update each night.

The following table describes the fields for office parameter RSC_ESASDUPD_BOOL and an example for each field.

Fields for RSC_ESASDUPD_BOOL

Field	Example
Name	RSC_ESASDUPD_BOOL
Type	BOOLEAN
Default	YES
Range	YES or NO

ESA Lines (continued)**RSC_ESASDUPD_HOUR**

The RSC_ESASDUPD_HOUR office parameter specifies the daily starting time for the update of static data each night.

The following table describes the fields for office parameter. The table has an example for each field.

Fields for RSC_ESASDUPD_HOUR

Field	Example
Name	RSC_ESASDUPD_HOUR
Type	ESASDUPD_TYPE
Default	2 (02:00 HR), the system uses a 24 h clock
Range	0 (00:00 HR) to 23 (23:00 HR)

Set this parameter so the data transfer does the following:

- occurs during a low-traffic period
- does not occur while you take an office image or while system software performs automatic routine exercise (REX) tests

Note: Static data takes between 3 and 5 min.

To determine when the REX is performed, view parameters CC-REX_SCHEDULED_HR and CMC_REX_SCHEDULED_HR in table OFCENG. The CC tests take 12 min and start 15 min after the time set in the parameter. The central message controller (CMC) tests take 15 min. The tests start 5 min after the time set in the parameter.

Modifying ESA parameters

To modify the following parameters, make the changes with the table editor:

- RSC_XPMESAEXIT
- RSC_ESAUPD_HOUR
- RSC_ESAUPD_BOOL

ESA Lines (continued)

Modifying parameters using the table editor

at the terminal

- 1 To access table OFCENG and position on the parameter, type
`>TABLE OFCENG;POS RSC_XPMESAEXIT`
- 2 To request a change of the parameter to the desired value, type
`>CHA`
- 3 To enter the new value, type
`>n`
where
n is the new exit delay in 10 s increases
- 4 To confirm the change, type
`>Y`
- 5 To quit the table editor, type
`>QUIT`

Use the following procedure to change an office parameter with the table editor. The example procedure will change the ESA exit parameter, RSC_XPMESAEXIT, in table OFCENG.

Operation

You must download data to the RCC2 before the RCC2 enters ESA. The ESA static data is a subset of translation data from the DMS CC. The system generates ESA logs when the downloaded data exceeds the RSC-S ESA maximum.

The RSC-S ESA mode cannot be entered until the ESA Task software is loaded with ESA static data.

If changes occur in any of the following tables, ESA static data from the DMS CC must be downloaded to the ESA task software.

- translation data tables
- table ESAPXLA
- table CUSTHEAD

ESA Lines (continued)

The following table describes the ESA CC data tables for both single and dual RCC2 (DRCC2) configurations.

ESA CC data tables

Table	Type	Maximum	Download warning
Terminal data	One per terminal	5760	
Automatic line	One per AUL line	256	ESA101
Customer group	One per group	288	ESA102
Prefix header	One per customer group	288	
Prefix table	One per ESA prefix translator		ESA103
	• POTS	16	
	• customer group	8	
Extension header	One per customer group	288	ESA103
EFG		2304	
ABCD	One per directory number	5760	ESA105
Hunt header	One per huntgroup	2000	ESA106
Hunt member	One per huntgroup	5000 (RCC2) 4999 (DRCC2)	ESA107
Office parameter		1	

Translations table flow

The ESA Lines translations tables are in the following list:

- Table CUSTHEAD links a customer group to the prefix translation table name identified in table ESAPXLA. Field XLANAME table CUSTHEAD corresponds to the prefix translator name assigned in field XLANAME from table ESAPXLA to access prefix translation data.
- Table ESAPXLA supports line-to-trunk, trunk-to-trunk and trunk-to-line call processing in the RSC-S during ESA. Table ESAPXLA contains special prefix translation data for POTS and IBN customers. Fields PMTYPE, SITE and RCCNO in table ESAPXLA correspond to the PMTYPE, SITENM, and RCCNO tuple from table RCCINV. Use the

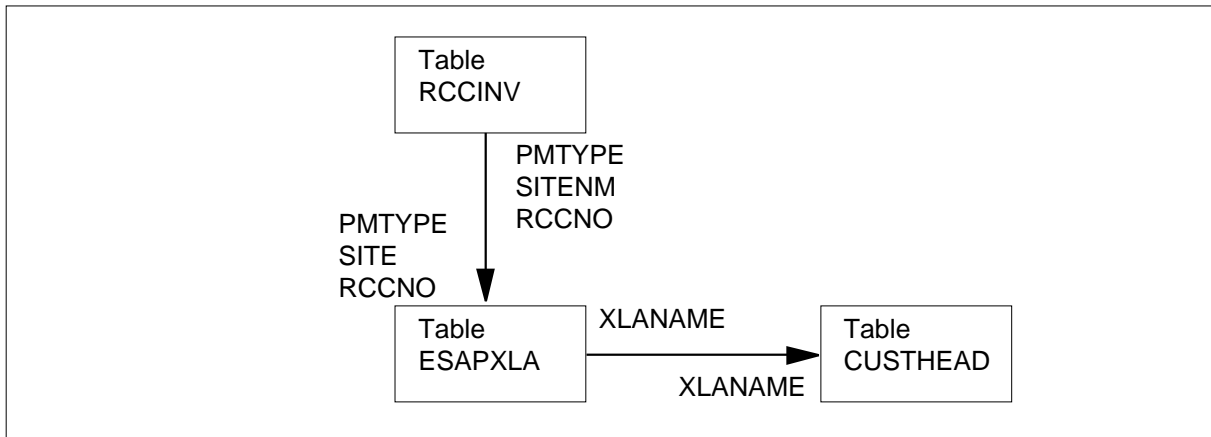
ESA Lines (continued)

fields to access inventory data (except P-side link assignments) for the identified RCC2.

- Table RCCINV maintains a list of RCC2s that are datafilled in the DMS system. Table RCCINV also contains inventory data (except P-side link assignments) for the RCC2s. The table information identifies the location of the RCC2, the required load and exec lineups and the network link connections. The C-side DS-1 assignments for the RCC2 are datafilled in table RCCINV. In addition, intraswitching is datafilled in table RCCINV.

The ESA Lines translation process appears in the following flowchart.

Table flow for ESA Lines



Load information for this table is datafilled in field LOAD. The information corresponds to the LOADNAME tuple from table PMLOADS. The RCCNAME tuple in table RCCINV also corresponds to the RCCNAME tuple from table RCCPSINV. Field RCCNAME stores site information entered in field NAME from table SITE. Field RCCNAME also stores the PM type and the PM number.

Limits

The following limits apply to ESA Lines:

- A maximum of 16 entries are allowed for each RSC-S when datafill is entered in table ESAPXLA for POTS.
- A maximum of eight entries are allowed for each RSC-S prefix translator name. The maximum applies when datafill is entered in table ESAPXLA for MDC customer groups.

Interactions

ESA Lines does not have functionality interactions.

ESA Lines (continued)**Activation/deactivation by the end user**

ESA Lines does not require activation or deactivation by the end user.

Billing

ESA Lines does not affect billing.

Station Message Detail Recording

ESA Lines does not affect Station Message Detail Recording.

Datafilling office parameters

The following table shows the office parameters ESA Lines use. For more information about office parameters, refer to *Office Parameters Reference Manual*.

Office parameters by function name RSC-ESA Lines

Table name	Parameter name	Explanation and action
OFCENG	RSC_ESA_NOTIFY_TONE	Defines if the subscriber will hear a tone burst when ESA is entered. Default: Y
	RSC_XPMESAEXIT	Delays ESA exit to prevent bouncing links. Default: 6
	RSC_ESASDUPD_BOOL	Specifies if nightly updates of static data must be performed. Default: YES
	RSC_ESASDUPD_HOUR	Specifies the start time for the daily update of ESA static data. Default: 2

Datafill sequence

The following table lists tables that require datafill to implement ESA Lines. The tables are listed in the order in which the tables are to be datafilled.

Datafill requirements for ESA Lines

Table	Purpose of table
RCCINV	Remote cluster controller inventory. This table contains the inventory data, except P-side link assignments, for RCC2.
ESAPXLA	Emergency Stand-Alone Translations. This table supports line-to-trunk, trunk-to-trunk and trunk-to-line call processing in the RSC-S during ESA. Table ESAPXLA contains special prefix translation data used for POTS and MDC customers.

ESA Lines (continued)

Datafilling table RCCINV

The remote cluster controller inventory (RCCINV) table contains the inventory data, except P-side link assignments, for the RCC2.

The following table shows the datafill specific to ESA Lines for table RCCINV. Only the fields that apply directly to ESA Lines appear. Refer to the *Translations Guide* for a description of the other fields.

Datafilling table RCCINV (Sheet 1 of 2)

Field	Subfield or refinement	Entry	Explanation and action
EXECUTAB		see subfields	Executive table. Subfields: TRMTYPE and EXEC. Note: More than one combination (maximum eight) can be used for a given PM.
	TRMTYPE	ESALINES	Terminal type. Enter the type of PM terminals used. Entry values include POTS for normal lines, KEYSET for MDC or data lines. The entry values also include RMM_TERM for remote maintenance module (RMM) terminals, ABTRK for regular trunks and ESALINES for ESA lines.
<p>Note 1: Make changes to fields with multiple entries in the PROMPT mode only. In nonprompt mode you can leave out existing entries.</p> <p>Note 2: Enter the continuation mark (+) in fields with multiple entries when more data is specified on the next line or more records will be entered. Enter the end mark (\$) in fields with multiple possible entries after the last entry.</p> <p>Note 3: When you enter datafill in field C-side link table (CSLNKTAB), make sure message links are not assigned to the same physical interface card. When the interface card supports two or more links, separate the message links by the number of links on the interface cards. The separation applies to all interface link types: DS-1, DS30, DS30A, or PCM-30. Table control will issue a warning if an attempt is made to assign message links on the same interface card. If message links are assigned to the same interface card, an E1 outage (failure of all message links) can occur. The outage occurs if the card fails.</p>			

ESA Lines (continued)**Datafilling table RCCINV (Sheet 2 of 2)**

Field	Subfield or refinement	Entry	Explanation and action
	EXEC	ESAEX	Executive programs. Enter the set of executive programs the system requires for the PM specified in the TRMTYPE entry. Entry values include POTSEX if TRMTYPE is POTS, KSETEX if TRMTYPE is KEYSET and RSMEX if TRMTYPE is RMM_TERM. Entry values also include DTCEX or FXODCM (depending on the type of trunking) if TRMTYPE is ABTRK and ESAEX if TRMTYPE is ESALINES.
ESA		Y or N	Emergency stand-alone. Entry values: Y (the RSC-S has the ESA option) or N (RSC-S does not have the ESA option).
<p>Note 1: Make changes to fields with multiple entries in the PROMPT mode only. In nonprompt mode you can leave out existing entries.</p> <p>Note 2: Enter the continuation mark (+) in fields with multiple entries when more data is specified on the next line or more records will be entered. Enter the end mark (\$) in fields with multiple possible entries after the last entry.</p> <p>Note 3: When you enter datafill in field C-side link table (CSLNKTAB), make sure message links are not assigned to the same physical interface card. When the interface card supports two or more links, separate the message links by the number of links on the interface cards. The separation applies to all interface link types: DS-1, DS30, DS30A, or PCM-30. Table control will issue a warning if an attempt is made to assign message links on the same interface card. If message links are assigned to the same interface card, an E1 outage (failure of all message links) can occur. The outage occurs if the card fails.</p>			

Datafill example for table RCCINV

The following examples show sample entries for table RCCINV. One example shows the sample entries are for an RCC2 supplied with the NTMX77AA UP. The other example shows the sample entries for an RCC2 supplied with the optional NTAX74AA CAP. The example are in the sequence given.

ESA Lines (continued)

MAP example for table RCCINV datafilled for NTAX74AA CAP

Table: RCCINV

RCCNAME	FRTYPE	FRNO	SHPOS	FLOOR	ROW	FRPOS	EQPEC	LOAD
CARY RCC2 0	CRSC	0	18	0	C	0	MX85AA	CRI08xx
EXECTAB								CONTMARK
(POTS POTSEX)(KEYSET KSETEX)(ABTRK DTCEX)(RMM_TERM RSMEX)								+
(ESALINES ESAEX)								\$
CSPM	CSLNKTAB							CONTMARK
LTC 1	(0)	(1)	(2)	(3)	(4)	(5)	(6)	(7)
								\$
ESA	INTRASW	OPTCARD					CMRLOAD	CONTMARK
Y	Y	(UTR6)	(MSGMX76	REM	HDLC)	(NT7X05AA	7)	(CMR18 CMRAG03)
								\$
TONESET	PROCPEC			E2LOAD				
NORTHAM	MX77AA	MX77AA	MX77xxxx					

Note 1: xx in field LOAD and xxxx in field E2LOAD represent alphanumeric entries. Examples of the entries include B1 and XE01, each in the sequence given.

Note 2: If the shelf has a processor other than NTMX77 or the optional NTAX74, field E2LOAD is automatically datafilled with value NILLOAD.

Note 3: When field PROCPEC is datafilled with AX74AA AX74AA instead of MX77AA MX77AA, the load name prefix in field LOAD changes from CRI to XRI. For example, CRI08xx (for MX77) changes to XRI08XX (for AX74AA). The following example shows sample datafill for table RCCINV when the RCC2 is datafilled for the NTAX74AA CAP.

ESA Lines (continued)**MAP example for table RCCINV datafilled for NTAX74AA CAP**

Table: RCCINV										
RCCNAME	FRTYPE	FRNO	SHPOS	FLOOR	ROW	FRPOS	EQPEC	LOAD		
CARY	RCC2	0	CRSC	0	18	0	C	0	MX85AA	XRI08xx
EXECTAB									CONTMARK	
(POTS POTSEX) (KEYSET KSETEX) (ABTRK DTCEX) (RMM_TERM RSMEX)									+	
(ESALINES ESAEX)									\$	
CSPM	CSLNKTAB								CONTMARK	
LTC	1	(0)	(1)	(2)	(3)	(4)	(5)	(6)	(7)	\$
ESA	INTRASW	OPTCARD					CMRLOAD		CONTMARK	
Y	Y	(UTR6) (MSG6X69)			(CMR18 CMRAG03)			(ISP16)		\$
TONESSET	PROCPEC			E2LOAD						
NORTHAM	AX74AA	AX74AA	AX74xxxx							

Datafilling table ESAPXLA

The ESA Trunk Translations tables support line-to-trunk, trunk-to-trunk and trunk-to-line call processing in the RSC-S during ESA. Table ESAPXLA contains special prefix translation data for POTS and IBN subscribers.

The system does not use Table ESAPXLA during normal operation of the RCC2 or RLCM. The translations are performed normally. Communications with the host can be lost and the RCC2 or RCLM can enter ESA mode. If this event occurs, the table ESAPXLA is used in the prefix translations.

ESA Lines (continued)

The following table shows the datafill specific to ESA Lines for table ESAPXLA. Only the fields that apply directly to ESA Lines appear. For a description of the other fields, refer to the *Translation Guide*.

Note: Table ESAPXLA must be datafilled before table CUSTHEAD.

Datafilling table ESAPXLA (Sheet 1 of 2)

Field	Subfield or refinement	Entry	Explanation and action
PXLAKEY		see explanation and action	Prefix translator key. This key identifies a set of prefix digits on a specific site for a particular set of customers. Subfields: XLANAME, NODE, and PREFIX.
	XLANAME	alphanumeric (eight characters maximum)	Prefix translator name. To perform this translation for any POTS line on the remote, enter ESAPOTS. To perform the translation for a particular MDC customer group, enter any name up to eight characters in table CUSTHEAD. Relate this name to a customer group in table CUSTHEAD.
	NODE	see explanation and action	Node. The RLCM, RCC, RCC2, or remote digital line module (RDLM) associated with the translator identified by XLANAME. Subfields: PMTYPE, LCMNO, SITE, and RCCNO.
	PMTYPE	RCC2	Peripheral module type. This field identifies the peripheral node as an RLCM, as an RCC, as an RCC2, or as an RDLM.
	SITE	alphanumeric	Site. Enter the name assigned to the location of the RCC2.
PXLAKEY (continued)	RCCNO	0-127	RCC number. For this field, enter the PM number of the RCC2.
	PREFIX	0-63	Prefix digits. Enter the 1 to 15-digit prefix to associate with the translation.
RESULT		see explanation and action	Translation result. This field defines the action to take when you dial the earlier defined prefix digits on the remote. Subfield: SEL and entries contingent on the value entered for SEL. Entry value: alphanumeric.

ESA Lines (continued)

Datafilling table ESAPXLA (Sheet 2 of 2)

Field	Subfield or refinement	Entry	Explanation and action
RESULT (continued)	SEL	L	Selector. If the entry in PREFIX specifies a line, enter L and complete subfields LEN, AMBIG and RNGCD.
	LEN	see explanation and action	Line equipment number. This field defines the line where the call terminates. This entry is alphanumeric. Subfields: SITE, FRAME, UNIT, LSG and CIRCUIT.
	SITE	alphanumeric	Site. Enter the name assigned to the site of the termination line. Communication with the host does not occur because the remote operates in the ESA. This site must match the site specified in subfield NODE.
	FRAME	0-99	Frame. Enter the frame number at this site that contains the line card for the termination line. Communication is supported between all the line concentrating modules (LCM) or the digital line modules (DLM) attached to the RCC2 for PMTYPE RCC2.
	UNIT	0 or 1	Unit. Enter the unit number of the LCM, RLCM, DLM, or RDLM where the line is assigned.
	AMBIG	Y or N	Ambiguous. If the prefix digits are all different, enter N. If the same digits can be dialed as the first digits of another number, enter Y. Entry value: Y or N.
	RNGCD	0-5	Ringing code. Enter the code for the type of ringing that associates with the line specified in the LEN field. The code is for lines on an LCM or DLM.

Datafill example for table ESAPXLA

The following example shows sample datafill for table ESAPXLA.

ESA Lines (continued)

MAP example for table ESAXPLA

```

Table: ESAPXLA

                                PXLAKY
-----
ESAPOTS      RCC2    CARY 0      411
IBN1         RCC2    CARY 0      6
IBN1         RCC2    CARY 0      9
ESATEST      RCC2    CARY 0     611

                                RESULT
-----
L           CARY 00    0    00 02      Y    1
T   SRPXL
T   SRPDXL
L           CARY 02    0    01 20      N    1
    
```

Datafilling table CUSTHEAD

The operating company personnel uses the Customer Group Head table (CUSTHEAD) to implement ESA lines. The CUSTHEAD table specifies the prefix translator name in table ESAXPLA for field XLANAME. An ESA prefix translator defines prefix translation data for RLCMs and RCC2s in ESA.

Datafilling table CUSTHEAD

Field	Subfield or refinement	Entry	Explanation and action
OPTIONS		ESAPXLA	Option. This field lists options and associated subfields, selected and assigned to the customer group. Enter the option.
	XLANAME	alphanumeric	Prefix translator name. Enter the one to eight characters assigned to the prefix translator table in field XLANAME of table ESAPXLA.
<p>Note: The operating company can specify all prefix translator names except POTS. The POTS prefix translator name is hard-coded as ESAPOTS. All nodes that require prefix translation for POTS use this prefix name and specify the node.</p>			

The following table shows datafill specific to ESA Lines for table CUSTHEAD. Only the fields that apply directly to ESA Lines appear. For a description of the other fields, refer to the *Translation Guide*.

Datafill example for table CUSTHEAD

The following example shows sample datafill for table CUSTHEAD.

MAP example for table CUSTHEAD

Table: CUSTHEAD

CUSTNAME CUSTXLA DGCOLNM OPTIONS

 POTSDATA POTSXLA POTS (VACTRMT 0)(EXTNCOS 0)
 COMIBN2 CXN2 IBN2 (VACTRMT 0)(EXTNCOS 0)

OPTIONS

 (SUPERCNF)(MHOLD 10 AUDIO)(CPR Y AUDIO1 3)
 (ESAPXLA IBN1)

Translation verification tools

The tool ESATRAVER allows operating company personnel to perform a translation verification (TRAVER) on ESA-specific translations. The tool allows the translations that occur during ESA to be verified.

SERVORD

The ESA Lines does not use SERVORD.

ESA Lines and Trunks

Functional group

BAS00012

Feature package

NTX149AB RSC ESA Operations—Lines and Trunks

Release applicability

BCS20 and up

Prerequisites

ESA Lines and Trunks requires the following feature packages:

- NTX000AA Bilge
- NTX001AA Common Basic
- NTX145AA Remote Switching Center
- NTX152AB RSC Trunking (upgrade of NTX152AA)
- NTX270AA New Peripheral Maintenance
- NTX901AA Local Features I

Note: Feature packages NTX150AA and NTXP92AA are removed from this table as prerequisite packages for feature package NTX149AB.

Description

Many of the concepts that apply to controlling ESA for lines also apply to trunks. ESA trunk translations always compare dialed digits with those in table ESAPXLA before searching any other translation table. Table ESAPXLA contains special prefix translation data for plain ordinary telephone service (POTS) and Integrated Business Network (IBN) customer groups for datafilling trunks. Table ESAPXLA provides directions to the translations process.

Table ESAPXLA contains fields that store the prefix translation (PXLKEY) and translation result (RESULT). PXLKEY defines a set of prefix digits on a specific remote for all POTS lines or for a particular IBN customer group. RESULT specifies what action to take when a POTS user or a member of that customer group on that site dials those digits.

One of the subfields of PXLKEY is the translator name (XLNAME). If the prefix translation is to be executed when those digits are dialed from any POTS line on this remote, ESAPOTS is datafilled in XLNAME. If the prefix

ESA Lines and Trunks (continued)

translation is to be executed when a certain IBN customer group dials those digits, an alphanumeric name of up to eight characters is datafilled in XLANAME. This same name must be associated with a particular IBN customer group in table CUSTHEAD.

ESA call processing determines the customer group from the data associated with the originator. The customer group data identifies the set of table ESAPXLA entries that must be searched. The default is ESAPOTS.

Six actions that translations can take are as follows:

- route to a line (selector L)
- route to treatment (selector T)
- route to hunt group (selector H)
- route to trunk with standard routing (selector R)
- route to trunk with direct routing (selector D)
- retranslate (selector A)

For selector L, connection is to be made to another line on the RCC2. Datafill uniquely identifies the line to which the connection is to be made.

For selector T, one of the following treatments is required: reorder tone, delete prefix, further translation, or delete prefix and give second dialtone followed by further translation.

For selector H, the call is to be routed to a hunt group. Datafill defines which hunt group to route. This hunt group must be defined in table HUNTGRP.

For selector R, connection is to be made to a trunk with standard routing. Datafill includes information about the route, the number of digits to collect, and the ambiguity of the code.

For selector D, connection is to be made to a trunk with direct routing. Datafill includes information about the route, the number of digits to collect, and second dialtone.

For selector A, digits are to be retranslated. Datafill includes information about another prefix translator and second dialtone.

Note: When selector R or D is chosen, the trunk or route must reside on the RSC-S.

ESA Lines and Trunks (continued)

The Emergency Stand-Alone Home Numbering Plan (ESAHNPA) table contains special prefix translation data used to select outgoing trunks. This table handles normal prefix translation for trunks. Exceptions are handled by table ESAPXLA.

There are two parts to table ESAHNPA: the prefix translation key (HNPAKEY) and the translation result (RESULT). Field HNPAKEY defines a set of prefix digits on a specific remote for all POTS lines or for a particular IBN customer group. Field RESULT specifies what action to take when those digits are dialed.

One of the subfields of HNPAKEY is the translator name (XLANAME). If prefix translation is to be executed when digits are dialed from any POTS line at the RSC-S, ESAPOTS is datafilled in XLANAME. If prefix translation is to be executed when a certain IBN customer group dials, an alphanumeric name of up to eight characters is datafilled in field XLANAME. This same name must be datafilled in table CUSTHEAD.

The only type of action that the translation can take is to connect the line to a standard route. The information needed to complete this translation is the number of digits to be collected, the name of the route, and whether or not the code is ambiguous. This is datafilled in table ESAHNPA.

The Emergency Stand-Alone Routing (ESARTE) table is created to allow greater flexibility in route selection. This table allows the operating company to plan various routes a call can take in ESA. Each entry in table ESARTE identifies the ESA trunk group on which to terminate, and (if necessary) the number of digits to delete.

The index to the route entry is contained in table ESAPXLA or table ESAHNPA. Alternate routing is not supported in ESA.

Translation for incoming line to outgoing trunk

ESA line translation examines the digits dialed by the subscriber, the switch (as a result of standard digit manipulation), or an automatic line. The digits are first compared with the entries in table ESAPXLA. If an entry in table ESAPXLA matches the received digits, the result is to route to a trunk. If there is no match, table ESAHNPA is searched. If a match is found, translation routes to a trunk. Table ESARTE is indexed based on the route referenced in tables ESAPXLA or ESAHNPA. The ESA trunk group data are identified in table ESARTE. Any digit manipulation indicated for a given route is done at this time.

ESA Lines and Trunks (continued)

Translation for incoming trunk to outgoing trunk or line

In ESA, any digit manipulation required on the incoming digits is described in the trunk group data of the originator. For example, for TI trunks, up to four digits can be added to the incoming digit stream. Or, if the number of incoming digits is variable, the minimum and maximum number expected can be specified. Translation will scan the translator specified in table ESAPXLA. For IBNTI trunks, only two digits can be added to the incoming digit stream. Dial tone may be expected. If the trunk is type NILPULSE, a four-digit directory number can be specified as the destination. Translation will scan the translator specified by the IBN customer group in table ESAPXLA.

To collect the trunk group data for an RCC2, the trunks residing on the RCC2 must be identified. Trunk groups are located on the peripheral side (P-side) of the RCC2.

For each port assigned as a trunk, the Common Language Location Identifier (CLLI) and external trunk number of its trunk circuits are used to address tables TRKMEM, TRKSGRP, TRKGRP, and ISTRKGRP.

If the information in the trunk tables indicates that the RCC2 ESA can support a unique trunk, the ESA specific data are collected and sent down to the RCC2.

Operation

Not applicable

Translations table flow

The ESA Lines and Trunks translations tables are described in the following list:

- Table ESAHNPA contains prefix translation used for normal prefix translation for trunks. The HNPKEY tuple is indexed by the RTEKEY tuple in table ESARTE to access the route entry.
- Table ESARTE identifies trunks that a call may be routed to during ESA. Field RTEKEY indexes into field HNPKEY (table ESAHNPA) or field PXLKEY (table ESAPXLA) to access the route entry.
- Table TRKMEM lists the data associated with each trunk assigned to one of the trunk groups and subgroups specified in tables TRKGRP and TRKSGRP. This table identifies the circuits associated with static trunks, dynamic trunks, and the test equipment used to test lines and trunks. Field CLLI in table TRKMEM corresponds to the CLLI code for the trunk group.
- Table TRKSGRP lists the supplementary information for each subgroup that is assigned to one of the trunk groups listed in table TRKGRP. Field

ESA Lines and Trunks (continued)

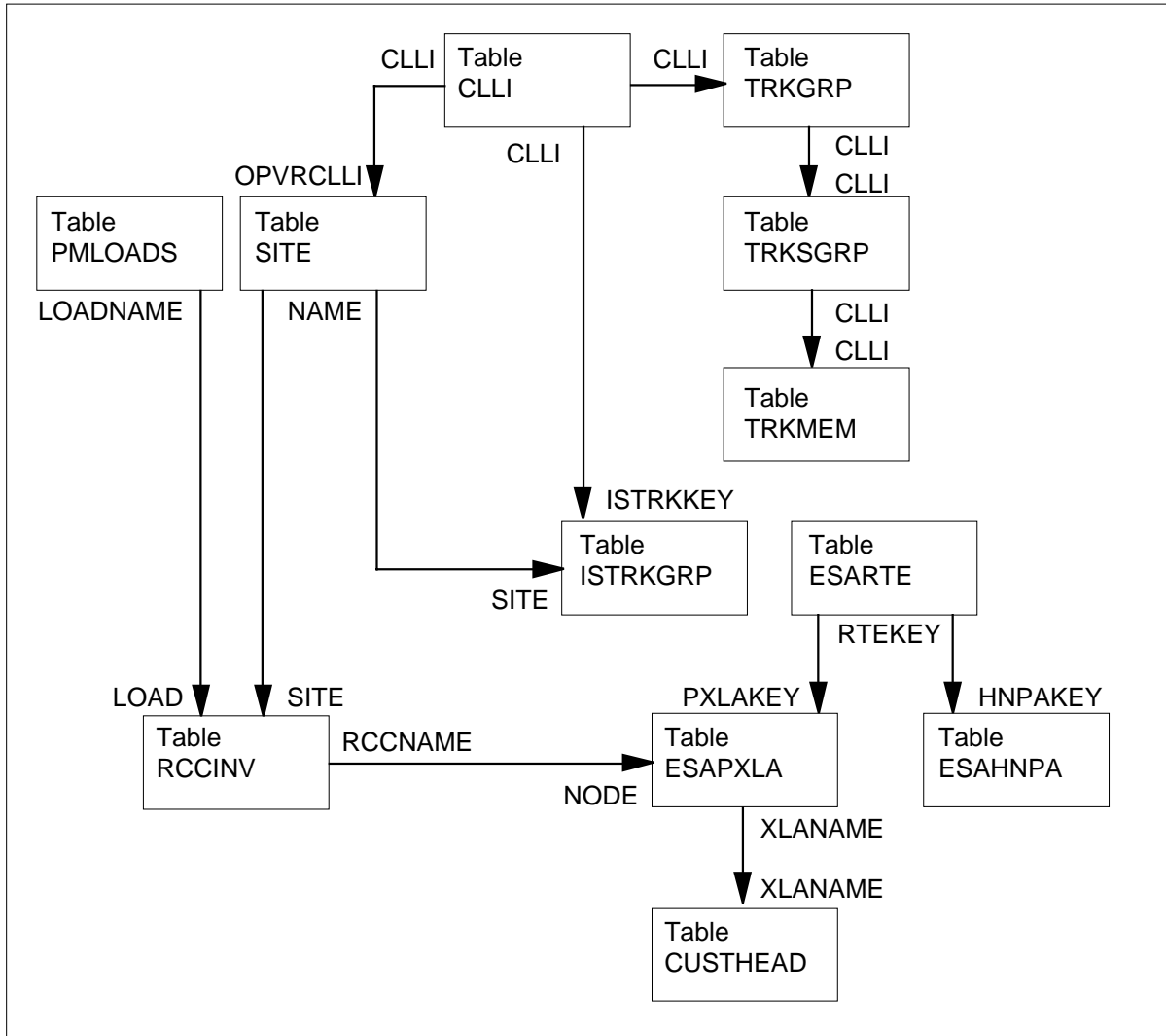
- CLLI in table TRKSGRP corresponds to the CLLI code for the trunk group.
- Table ISTRKGRP controls the dynamic nature of the trunks located on an RCC2. An entry in this table indicates that a trunk group has dynamic capability. Subfield SITE_ID in table ISTRKGRP corresponds to the NAME tuple from table SITE to identify the equipment for the switching unit and for all remote locations that home on to it. Field ISTRKKEY in table ISTRKGRP corresponds to the CLLI tuple from table CLLI that identifies the trunk group that should be assigned dynamic capability.
 - Table TRKGRP defines data for each trunk group associated with the switching unit. Field CLLI in table TRKGRP corresponds to the CLLI code for the trunk group.
 - Table CUSTHEAD links a customer group to the prefix translation table name as identified in table ESAPXLA if the translation is performed for a particular IBN customer group. Field XLANAME table CUSTHEAD corresponds to the prefix translator name assigned in field XLANAME from table ESAPXLA to access prefix translation data.
 - Table ESAPXLA is used to exceptions rather than normal prefix translation for ESA. Table ESAPXLA contains special prefix translation data used for POTS and IBN customers. The PXLAKKEY tuple is indexed by the RTEKEY tuple in table ESARTE to access the route entry. The NODE tuple in table ESAPXLA correspond to the RCCNAME tuple from table RCCINV to access RCC2 inventory data (except P-side link assignments).
 - Table RCCINV maintains a list of RCC2s that are datafilled in the DMS system and contains inventory data (except P-side link assignments) for the RCC2s. The table information identifies where the RCC2 is located, the load and exec lineups required, and the network link connections. Central side (C-side) DS-1 assignments for the RCC2 are datafilled in table RCCINV. In addition, intraswitching is datafilled in table RCCINV.

Load information for this table is datafilled in field LOAD and corresponds to the LOADNAME tuple from table PMLOADS. Also, the RCCNAME tuple in table RCCINV corresponds to the NODE tuple from table ESAPXLA. Field RCCNAME stores site information (originally entered in field NAME from table SITE), the PM type, and PM number.

The ESA Lines and Trunks translation process is shown in the flowchart that follows.

ESA Lines and Trunks (continued)

Table flow for ESA Lines and Trunks



Limitations and restrictions

ESA Lines and Trunks has no limitations or restrictions.

Interactions

ESA Lines and Trunks has no functionality interactions.

Activation/deactivation by the end user

ESA Lines and Trunks requires no activation or deactivation by the end user.

ESA Lines and Trunks (continued)

Billing

ESA Lines and Trunks does not affect billing.

Station Message Detail Recording

ESA Lines and Trunks does not affect Station Message Detail Recording.

Datafilling office parameters

The following table shows the office parameters used by ESA Lines and Trunks. For more information about office parameters, refer to the *Office Parameters Reference Manual*.

Office parameters used by ESA Lines and Trunks

Table name	Parameter name	Explanation and action
OFCENG	RSC_ESA_NOTIFY_TONE	Defines whether the subscriber hears a tone burst when ESA is entered. Default: Y.
	RSC_XPMESAEXIT	Delays ESA exit to prevent bouncing links. Default: 6.
	RSC_ESASDUPD_BOOL	Specifies whether nightly updates of static data should be performed. Default: Y.
	RSC_ESASDUPD_HOUR	Specifies the starting time of the daily update of ESA static data. Default: 2.

Datafill sequence

The following table lists the tables that require datafill to implement ESA Lines and Trunks. The tables are listed in the order in which they are to be datafilled.

Datafill tables required for ESA Lines and Trunks (Sheet 1 of 2)

Table	Purpose of table
RCCINV	Remote Cluster Controller Inventory. Contains inventory data (except P-side inventory assignments) for the RCC2. C-side digital signal 1 (DS-1) assignments for the RCC2 are datafilled in table RCCINV.
ESAPXLA	Emergency Stand-Alone Prefix Translation. Supports line-to-trunk, trunk-to-trunk, and trunk-to-line call processing in the RSC-S during ESA. Also contains special prefix translation data for POTS and IBN customer groups.
CUSTHEAD	Customer Group Head. Links a customer group to the prefix translation table name as identified in table ESAPXLA.

ESA Lines and Trunks (continued)

Datafill tables required for ESA Lines and Trunks (Sheet 2 of 2)

Table	Purpose of table
TRKGRP	Trunk Group. Lists the characteristics of each trunk group.
ISTRKGRP	RCC Dynamic Trunk Groups. Controls the dynamic nature of the trunks located on an RCC2. An entry in this table indicates that a trunk group has dynamic capability.
TRKSGRP	Trunk Subgroup. Lists the supplementary information for each subgroup which is assigned to one of the trunk groups listed in table TRKGRP.
TRKMEM	Trunk Member. Contains the address of the actual trunk member. Each trunk member residing on an RCC2 has terminal data associated with it.
ESARTE	Emergency Stand-Alone Routing. Identifies trunks that a call may be routed to during ESA.
ESAHNPA	Emergency Stand-Alone Home Numbering Plan. Allows the subscriber to select one of the trunks referenced in table ESARTE.

Trunk data are required to process line-to-trunk, trunk-to-line, and trunk-to-trunk calls in the RCC2 ESA environment. Table Trunk Group (TRKGRP) and table Trunk Subgroup (TRKSGRP) data are collected and downloaded to the expanded peripheral module (XPM) as ESA trunk data. The trunk group data contains translation and signaling information relevant to trunks supported in ESA.

Tables TRKGRP, TRKSGRP, ISTRKGRP, and TRKMEM describe the trunk attributes. Trunk members with the same attributes are grouped together under a common trunk name or CLLI.

Datafilling table RCCINV

The Remote Cluster Controller Inventory (RCCINV) table contains the inventory data, except P-side link assignments, for the RCC2. Tuple ESA must be datafilled as Y(es) to enable ESA capability.

ESA Lines and Trunks (continued)

The following table shows the datafill specific to ESA Lines and Trunks for table RCCINV. Only those fields that apply directly to ESA Lines and Trunks are shown. Refer to the *Translations Guide* for a description of the other fields.

Datafilling table RCCINV

Field	Subfield or refinement	Entry	Explanation and action
EXECTAB		see list	Executive table. Subfields: TRMTYPE, EXEC, and CONTMARK. More than one combination (8 maximum) can be used for a given PM. Note: Changes to fields with multiple entries should be made in the PROMPT mode only.
	TRMTYPE	ESALINES	Terminal type. Enter the type of PM terminals used. Entry values include POTS for regular lines, KEYSET for IBN/data lines, RMM_TERM for RMM terminals, ABTRK for regular trunks, and ESALINES for ESA lines.
	EXEC	ESAEX	Executive programs. Enter the set of executive programs required for the PM specified in the TRMTYPE entry. Entry values include POTSEX if TRMTYPE is POTS, KSETEX if TRMTYPE is KEYSET, RSMEX if TRMTYPE is RMM_TERM, DTCEX or FXODCM (depending on the type of trunking) if TRMTYPE is ABTRK, and ESAEX if TRMTYPE is ESALINES.
	CONTMARK	+ or \$	Continuation mark. Enter a plus sign (+) when the vector continues on the next record. Enter a dollar sign (\$) to indicate the end of the vector.
ESA		Y or N	Emergency stand-alone. Y indicates the RSC-S has the ESA option. N indicates the RSC-S does not have the ESA option.
<p>Note: When datafilling field C-side link table (CSLNKTAB), assure message links are not assigned to the same physical interface card. When the interface card supports two or more links, separate the message links by the number of links on the interface cards. This applies to all interface link types; DS-1, DS30, DS30A, or PCM-30. Table control will issue a warning if an attempt is made to assign message links on the same interface card. Assigning message links to the same interface card can cause an E1 outage (failure of all message links) if the card fails.</p>			

ESA Lines and Trunks (continued)

Datavill example for table RCCINV

The following example shows sample datavill for the ESA Lines and Trunks in table RCCINV for both an RCC2 provisioned with the NTMX77AA UP and an RCC2 provisioned with the optional NTAX74AA CAP, respectively.

MAP display example for table RCCINV datavilled for NTMX77AA UP

Table: RCCINV											
RCCNAME	FRTYPE	FRNO	SHPOS	FLOOR	ROW	FRPOS	EQPEC	LOAD			
MELB	RCC2	0	CRSC	0	5	0	C	0	MX85AA	CRI08xx	
EXECTAB											
(POTS POTSEX) (KEYSET KSETEX) (ABTRK DTCEX)											
(RMM_TERM RSMEX) (ESALINES ESAEX)										\$	
CSPM											
CSLNKTAB											
LTC	1	(0)	(1)	(2)	(3)	(4)	(5)	(6)	(7)	\$	
ESA INTRASW OPTCARD CMRLOAD											
Y	Y	(UTR6)	(MSG6X69)	(NT7X05AA	7)	(CMR18	CMRAG03)				\$
TONESET											
PROCPEC			E2LOAD			EXTINFO					
NORTHAM	MX77AA	MX77AA	MX77xxxxx			CEXT 0 4 0 E 15 MX86AA L					

Note 1: xx in field LOAD and xxxxx in field E2LOAD represent alphanumeric entries, for example B1 and XE01, respectively.

Note 2: If the shelf is equipped with a processor other than NTMX77 or the optional NTAX74, field E2LOAD is automatically datavilled with value NILLOAD.

Note 3: When field PROCPEC is datavilled with AX74AA AX74AA instead of MX77AA MX77AA, the load name prefix in field LOAD changes from CRI to XRI. For example, CRI08xx (for MX77) changes to XRI08XX (for AX74AA). The following example shows sample datavill for table RCCINV when the RCC2 is datavilled for the NTAX74AA CAP.

ESA Lines and Trunks (continued)

MAP display example for table RCCINV datafilled for NTAX74AA CAP

```

Table: RCCINV
RCCNAME      FRTYPE FRNO SHPOS FLOOR ROW FRPOS   EQPEC   LOAD
-----
MELB RC02 0   CRSC   0    5    0    C    0    MX85AA  XRI08xx

EXECTAB
(POTS POTSEX)(KEYSET KSETEX)(ABTRK DTCEX)
(RMM_TERM RSMEX) (ESALINES ESAEX)           $

CSPM          CSLNKTAB
-----
LTC 1         (0) (1) (2) (3) (4) (5) (6) (7)           $

ESA  INTRASW   OPTCARD                      CMRLOAD
-----
Y    Y          (UTR6)(MSG6X69)    (CMR18 CMRAG03)    (ISP16)           $

TONESET  PROCPEC          E2LOAD          EXTINFO
-----
NORTHAM  AX74AA  AX74AA  AX74xxxxx  CEXT 0 4 0 E 15 MX86AA L
    
```

Datafilling table ESAPXLA

The ESA Trunk Translations tables are used to support line-to-trunk, trunk-to-trunk, and trunk-to-line call processing in the RSC-S during ESA. Table ESAPXLA contains special prefix translation data used for POTS and IBN customers.

During regular operation of the RCC2 or RLCM, this table is not used and translations are performed in CC. If, however, communication with the host is lost and the RCC2 or RLCM enters ESA mode, this table is used in the prefix translations.

The following table shows the datafill specific to ESA Lines and Trunks for table ESAPXLA. Only those fields that apply directly to ESA Lines and

ESA Lines and Trunks (continued)

Trunks are shown. Refer to the *Translations Guide* for a description of the other fields.

Note: Table ESAPXLA must be datafilled before table CUSTHEAD.

Datafilling table ESAPXLA (Sheet 1 of 3)

Field	Subfield or refinement	Entry	Explanation and action
PXLAKEY		see subfields	Prefix translator key. This key identifies a set of prefix digits on a certain site for a particular set of customers. Subfields: XLANAME, NODE, and PREFIX.
	XLANAME	alphanumeric (8 characters maximum)	Prefix translator name. If this translation is to be performed for any POTS line on the remote, enter ESAPOTS. If it is to be performed for a particular IBN customer group, enter any name up to 8 characters and relate this name to a customer group in table CUSTHEAD.
	NODE	see subfields	Node. Subfields: PMTYPE, LCMNO, SITE, and RCCNO. This entry is alphanumeric.
	PMTYPE	RCC2	Peripheral module type. This subfield identifies the peripheral node as either an RLCM, an RCC, an RCC2, or an RDLM.
	LCMNO	not applicable	LCM number
	SITE	alphanumeric	Site. Enter the name assigned to the location of the RCC2.
	RCCNO	0 -255	RCC number. Enter the PM number of the RCC2.
	PREFIX	0-63	Prefix digits. Enter the 1- to 15-digit prefix with which the translation is to be associated.
RESULT		see subfield	Translation result. This field defines the action to be taken when the previously defined prefix digits are dialed on the remote. Subfield: SEL and entries contingent on the value entered for SEL. This entry is alphanumeric.
Note: Routes for the R and D selectors must be in table ESARTE before the selectors can be used.			

ESA Lines and Trunks (continued)

Datafilling table ESAPXLA (Sheet 2 of 3)

Field	Subfield or refinement	Entry	Explanation and action
	SEL	L, H, A, R, D, or T	Selector. Enter the selector multiple with the subfields L for line equipment numbe (LEN), H for hunt group (HTGRP), A for alternate translator (XLANAME), R for route (RR) with standard translations, D for routing with direct translations, T for treatment (TRMT) and datafill the subfields,
	L	see subfields	If selector is L then enter subfields; terminating LEN, ambiguous code (AMBIG) (Yor N), and the ring code (RNCD) (0 to 7).
	H	see subfields	If selector H enter subfields; hunt group (HTGRP) number from table HUNTGRP, sequence number (SEQNO) from table HUNTMEM and specify if the prefix digit is ambiguous (AMBIG) code (Y or N).
	A	see subfields	If selector is A then enter subields: multiple with an alternate translator name, and specify if a second dial tone (Y or N) is desired. Default alternate translators are: <ul style="list-style-type: none"> • NPXLA—no prefix translations • ESAPOTS—standard translations • ESATRMT—retranslate
	R	see subfields	If selector is R then enter subfields; multiple with the route number (RR) from table ESARTE, for standard trunking translations, number of digits (NUMDIG) to outpulse to outpulse and specify if prefix is AMBIG (Y or N).
<p>Note: Routes for the R and D selectors must be in table ESARTE before the selectors can be used.</p>			

ESA Lines and Trunks (continued)**Datafilling table ESAPXLA (Sheet 3 of 3)**

Field	Subfield or refinement	Entry	Explanation and action
	D	see subfields	If selector is D then enter subfields; multiple with the route number (RR) from table ESARTE, for direct trunking translations, number of digits (NUMDIG) to outpulse and specify if a second dial tone (Y or N) is desired.
	T	see subfields	If selector is T enter special treatments to be applied to the call. Treatments are: <ul style="list-style-type: none"> • REORDER—a fast busy tone • SRPXL—strip the prefix digit and translate dialed digits • SRPDXLA—strip the prefix digit, provide a second dial tone and translate dialed digits

Note: Routes for the R and D selectors must be in table ESARTE before the selectors can be used.

Datafill example for table ESAPXLA

The following example shows sample datafill for table ESAPXLA.

MAP display example for table ESAPXLA

Table: ESAPXLA										
			PXLKEY				RESULT			

ESAPOTS	RCC	REM1	0	411	L	REM100	0	00	02	Y 1
IBN1	RCC	REM1	0	4					T	REORDER
IBN1	RCC	REM1	0	6					T	SRPXL
IBN1	RCC	REM1	0	9					T	SRPDXLA
IBN1	RCC	REM1	0	7	H				5 7	Y
IBN2	RCC	REM1	0	0	A					ESATRMT Y
ESAPOTS	RCC	REM1	0	5	R				21 7	Y
ESAPOTS	RCC	REM1	0	8	D				10 4	N

Datafilling table CUSTHEAD (IBN only)

The Customer Header (CUSTHEAD) table links a customer group to the prefix translation table name identified in table ESAPXLA.

For IBN lines, it is necessary to link the information in the ESAPXLA prefix tables to a particular customer group. The option ESAPXLA is used to specify the prefix translator name associated with the customer group.

ESA Lines and Trunks (continued)

With ESA, datafill fields OPTION and XLANAME of table CUSTHEAD. If the OPTION field does not have the ESAPXLA option set, no prefix translation for that customer group is provided.

The following table shows the datafill specific to ESA Lines and Trunks for table CUSTHEAD. Only those fields that apply directly to ESA Lines and Trunks are shown. Refer to the *Translations Guide* for a description of the other fields.

Datafilling table CUSTHEAD

Field	Subfield or refinement	Entry	Explanation and action
OPTIONS		alphanumeric (ESAPXLA)	Option. Enter the option ESAPXLA.
	XLANAME	alphanumeric (1 to 8 characters)	Translator name. Enter the 1 to 8 characters assigned to the prefix translator in table ESAPXLA.
Note: Table ESAPXLA must be datafilled before table CUSTHEAD.			

Datafill example for table CUSTHEAD (IBN only)

The following example shows sample datafill for table CUSTHEAD.

ESA Lines and Trunks (continued)**MAP display example for table CUSTHEAD**

Table: CUSTHEAD			
CUSTNAME	CUSTXLA	DGCOLNM	CONTMARK
POTSDATA	POTSXLA	POTS	+
COMIBN2	CXN2	IBN2	+
IBNGRP10B	CXN2	IBN2	+
RSCTRKTST	CXN2	IBN2	+
OPTIONS			CONTMARK
(VACTRMT 0)(EXTNCOS 0)			\$
(VACTRMT 0)(EXTNCOS 4)(SUPERCNF)(MHOLD 10 AUDIO1) (CPR Y AUDIO1 3)(ESAPXLA IBN1)			+ \$
(VACTRMT 0)(EXTNCOS 4)(ACCT 5)(AUTH COMIBN2 N N) (AUTH COMIBN2 N N)(SUPERCNF)(MHOLD 10 AUDIO1) (ACR ACCT 1)(CPK B 100)(ESAPXLA IBN1)			+ + \$
(VACTRMT 0)(EXTNCOS 4)(ACCT 5)(AUTH COMIBN2 N N) (MHOLD 10 AUDIO1)(ACR ACCT 1)(CPK N 100) (ESAPXLA IBN1)			+ + \$

Datafilling table TRKGRP

Table TRKGRP lists the characteristics of each trunk group. The field values are unchanged for ESA trunking. Refer to the *Translations Guide* for a description of the other fields.

Datafilling table ISTRKGRP

Table ISTRKGRP controls the dynamic nature of the trunks located on an RCC2. An entry in this table indicates that a trunk group has dynamic capability. This table contains the following information: the name or CLI of the trunk group, the site of the RCC2, and the RCC2 to which the trunk group is restricted. The field values are unchanged for ESA trunking.

Datafilling table TRKGRP

Refer to the *Translations Guide* for a description of the other fields.

ESA Lines and Trunks (continued)

Datafilling table TRKSGRP

Table TRKSGRP lists the supplementary information for each subgroup assigned to one of the trunk groups listed in table TRKGRP. The field values are unchanged for ESA trunking.

Refer to the *Translations Guide* for a description of the other fields.

Datafilling table TRKMEM

Table TRKMEM contains the address of the actual trunk member. Each trunk member residing on an RCC2 has associated terminal data.

If the information in the trunk tables indicates that the RCC2 ESA can support a unique trunk, the ESA-specific data are collected and sent down to the XPM. The field values are unchanged for ESA trunking.

Refer to the *Translations Guide* for a description of the other fields.

Datafilling table ESARTE

Table ESARTE identifies trunks to which a call may be routed during ESA. Table ESARTE format is similar to tables OFRT and IBNRTE. There is a maximum of 255 unique routes for each RCC2. One selector is supported.

Refer to the *Translations Guide* for a description of the other fields.

Datafilling table ESAHNPA

Table ESA Home Numbering Plan Area (ESAHNPA) associates the subscriber with one of the trunks referenced in table ESARTE.

Prefix trunk entries for each customer group on each RCC2 node are provided. The prefix digits identified in table ESAHNPA represent regular access codes to ESA trunk routes. A maximum of 32 access codes are available to POTS subscribers. A maximum of 16 access codes are available for each IBN customer group.

Table ESAHNPA has data structures identical to table ESAPXLA. Only one selector is applicable to trunking in table ESAHNPA.

The following table shows the datafill specific to ESA Lines and Trunks for table ESAHNPA. Only those fields that apply directly to ESA Lines and

ESA Lines and Trunks (continued)

Trunks are shown. Refer to the *Translations Guide* for a description of the other fields.

Datafilling table ESAHNPA (Sheet 1 of 2)

Field	Subfield or refinement	Entry	Explanation and action
HNPAKEY		see subfields	ESAHNPA key. This key identifies a set of prefix digits on a certain site for a particular set of customers. Subfields: XLANAME, NODE, and PREFIX.
	XLANAME	alphanumeric (8 characters maximum)	Prefix translator name. If this translation is to be performed for any POTS line on the remote, enter ESAPOTS. If this translation is to be performed for a particular IBN customer group, enter any name (8 characters maximum) and relate it to a customer group in table CUSTHEAD.
	NODE	see subfields	Node. This field is the RCLM or RCC2 node associated with the translator identified by XLANAME. Subfields: PMTYPE, SITE, and RCCNO.
	PMTYPE	RCC2	Peripheral module type. Identifies the PM as an RCC2. SITE and RCCNO must be datafilled.
	SITE	alphanumeric	Site. Enter the name assigned to the location of the RCC2.
	RCCNO	0-255	RCC2 number. This specifies the RCC2 number as it is identified in the key field of table RCCINV.
	PREFIX	numeric (1 to 15 digits)	Prefix digits. Enter the prefix associated with the translation (15 digits maximum).
RESULT		see subfields	Translation result. This field defines the action to be taken when the previously defined prefix digits are dialed on the remote. Subfields: SEL, RR, NUMDIG and AMBIG.
<p>Note: For an AMBIG selection, digits 123 is considered ambiguous if another acceptable number is 12356. If N is entered, the switching process begins immediately after those prefix digits are dialed. If Y is entered, the remote waits for further digits. If none are entered during a given time period, the switching process begins.</p>			

ESA Lines and Trunks (end)

Datafilling table ESAHNPA (Sheet 2 of 2)

Field	Subfield or refinement	Entry	Explanation and action
RESULT (continued)	SEL	R	Selector. If the prefix digits entered in the PREFIX field specify a standard route, enter R and complete subfields RR, NUMDIG, and AMBIG.
	RR	0-255	Route reference index. Specify the index of the route described in ESARTE to which translation is to proceed.
	NUMDIG	0-15	Collect digits. Specify the number of digits to collect before outpulsing.
	AMBIG	Y or N	Ambiguous. Entry values: N (the prefix digits are completely unique), or, Y (the same digits may be dialed as the first digits of another number, enter Y).

Note: For an AMBIG selection, digits 123 is considered ambiguous if another acceptable number is 12356. If N is entered, the switching process begins immediately after those prefix digits are dialed. If Y is entered, the remote waits for further digits. If none are entered during a given time period, the switching process begins.

Datafill example for table ESAHNPA

The following example shows sample datafill for table ESAHNPA.

MAP display example for table ESAHNPA

```

Table: ESAHNPA

HNPAKEY                                RESULT
-----
ESAPOTS  RCC2  CARY  0   321   R   1   7   N
    
```

Translation verification tools

To verify the translations that occur during ESA, ESATRAVER allows the operating company personnel to perform a translation verification (TRAVER) on ESA-specific translations.

SERVORD

ESA Lines and Trunks does not use SERVORD.

Dual Remote Cluster Controller 2

Functional group

BAS00012

Feature package

NTX380AA Dual Remote Cluster Controller

Release applicability

BCS26 and up

Prerequisites

Dual Remote Cluster Controller 2 (DRCC2) requires the following feature packages:

- NTX000AA Bilge
- NTX001AA Common Basic
- NTX145AA Remote Switching Center
- NTX150AA RSC-Intra RSC Calling
- NTX269AA Universal Tone Receiver (Domestic)
- NTX270AA New Peripheral Maintenance Package
- NTX901AA Local Features

Note: Feature packages NTX149AA, NTX149AB, NTX152AB, and NTXP92AA are removed as prerequisite packages for feature package NTX380AA.

Description

Datafill requirements for DRCC2 basically are the same as for a single RCC2. This chapter describes how to datafill interlinks and how trunk groups are affected.

Table RCCINV

Table RCCINV sets up the configuration of C-side links to the host line group controller (LGC) or line trunk controller (LTC). Use this table to change the C-side configuration when the DRCC2 is being either implemented or changed.

Note: All the links can be deleted except message interlinks 0 and 8.

Dual Remote Cluster Controller 2 (continued)

Table IRLNKINV

Table Interlink Inventory (IRLNKINV) contains an entry for every RCC2 datafilled in table RCCINV and defines DRCC2 link assignments. This table also contains field ESAFORCE, which allows the operating company the option to have the RCC2 enter forced ESA.

When changing a DRCC2 configuration to a single RCC2 configuration, delete the RCC2 configuration in the IRLNKINV table by entering the dollar sign (\$) for the INTERRCC and carriage returns [CR] for the links.

Note: When no dual RCC2s exist, no interlinks are defined in table IRLNKINV.

Changing the interconnected RCC2

If a new RCC2 name is entered for field INTERRCC, the existing interconnected RCC2 is disconnected and the new RCC2 is connected. This is allowed only if the following conditions are met:

- All existing interlinks are manually busy (ManB), or at least one of the existing RCC2s of the DRCC2 is in an ManB or offline (OFFL) state.
- None of the P-side ports of the new interconnected RCC2 entered as a port pair are already in use.

Changing an interlink assignment

An interlink configuration can be changed by adding, deleting, or relocating interlinks. Following is a summary of tasks involved in each activity.

Adding an interlink

In table IRLNKINV, add the new port pairs after the existing ones have been prompted. If a port is already used as a C-side link, interlink, or dynamic trunk, the new data is rejected.

Deleting an interlink

Ensure that the interlink is busy or at least one RCC2 is busy or offline. Then, for example, use the CHANGE command to change the port (6, 11) to (6 NILPORT), (NILPORT 11), or (NILPORT NILPORT).

Relocating an interlink

Ensure that the interlink is busy or at least one RCC2 is busy or offline. Also ensure that the port that is going to become an interlink is not already in use. If the new port is a C-side link to the host PM, that link and all subsequent links must be busied. In table IRLNKINV, enter the new port pair, which may mean one new port number for either RCC2 or two new port numbers.

Dual Remote Cluster Controller 2 (continued)

DRCC office parameters

If an RCC2 in forced ESA loses messaging to the interconnected RCC2, the OFCENG parameter RSC-S_ESAENTRY_BADLINK determines how long the RCC2 in forced ESA will wait before exiting ESA and reestablishing communication with the host peripheral module (PM).

Operation

Not applicable

Translations table flow

The Dual Remote Cluster Controller 2 translations tables are described in the following list:

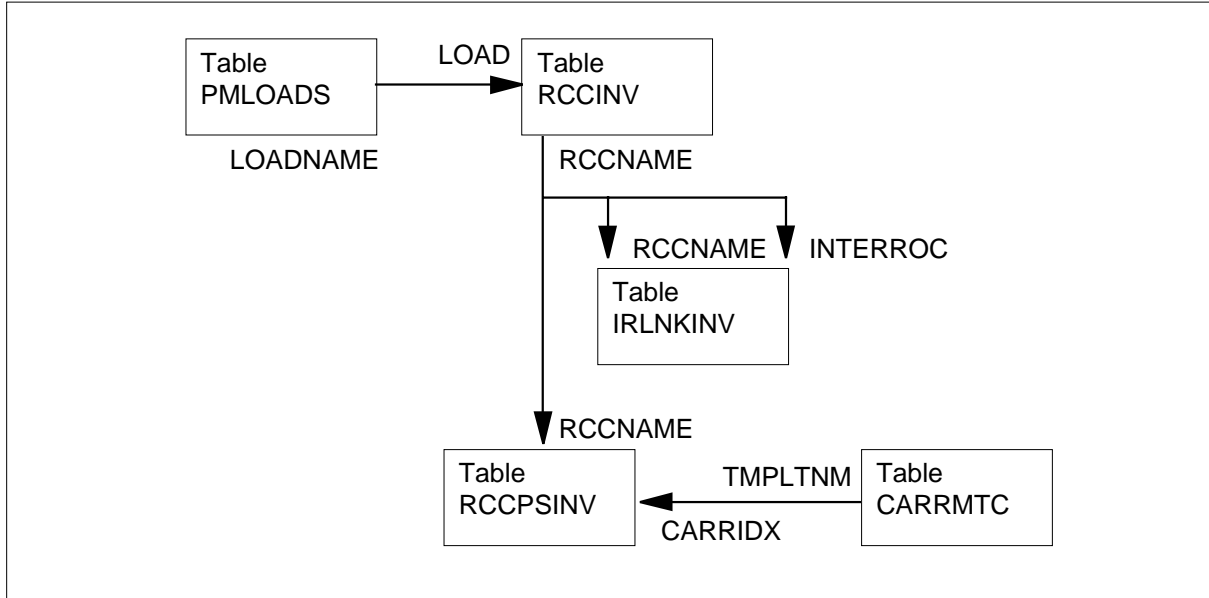
- Table RCCPSINV contains only the P-side link assignments for the RCC2. When a tuple is added in table RCCINV, a corresponding tuple is added automatically in table RCCPSINV. Field CARRIDX indexes into table CARRMTC for maintenance control information about peripheral. The RCCNAME tuple in table RCCPSINV corresponds to the RCCNAME tuple from table RCCINV and stores site information, originally entered in field NAME from table SITE, the PM type, and PM number. Also, the RCCNAME tuple in table RCCPSINV corresponds to the table IRLNKINV inventory datafill for the spouse and mate RCC2.
- Table IRLNKINV allows the operating company to configure a new DRCC2. This table is accessed to reference the physical configuration of the interlinks between the RCC2s of a DRCC2. Field RCCNAME in table IRLNKINV corresponds to the RCCNAME tuple from table RCCINV.
- Table RCCINV maintains a list of RCC2s that are datafilled in the DMS system and contains inventory data, except P-side link assignments, for the RCC2s. The table information identifies where the RCC2 is located, the load and exec lineups required, and the network link connections. C-side DS-1 assignments for the RCC2 are datafilled in table RCCINV. In addition, intraswitching is datafilled in table RCCINV.

Load information for this table is datafilled in field LOAD and corresponds to the LOADNAME tuple from table PMLOADS. Also, the RCCNAME tuple in table RCCINV corresponds to the RCCNAME tuple from table RCCPSINV. Field RCCNAME stores site information, originally entered in field NAME from table SITE, the PM type, and PM number.

The following flowchart shows the Dual Remote Cluster Controller 2 translation process.

Dual Remote Cluster Controller 2 (continued)

Table flow for Dual Remote Cluster Controller 2



Limitations and restrictions

The following limitation and restriction applies to assigning C-side links:
When changing the interlink configuration involves changing the C-side links, the relevant links and all subsequent links must be busied.

The following limitations and restrictions apply to assigning trunk groups:

- A trunk group cannot be split between the two RCC2s.
- Unequipped C-side ports cannot be reconfigured as interlinks if the ports are already assigned for dynamic trunks.

The following limitations and restrictions apply to setting up ESA:

- Entries in table ESAPXLA are specific to an RCC2 and are transparent to the mate RCC2 and are not allowed to interswitch. Therefore, each RCC2 in a dual RCC2 (DRCC2) configuration, must have its own entries in table ESAPXLA to define the location of special translations terminations (such as 0, 011, 411, 911).
- Lines terminating on an RCC2, for special translations, must be datafilled in table ESAPXLA to one of the 16 tuples allowed for that RCC2. Trunks being datafilled for special translations can not terminate on the spouse RCC2 through table ESAPXLA. However, since the entries in table ESAPXLA are transparent to the spouse RCC2, the datafilled RCC2 will only search its own memory, an entry must be made for both RCC2s of the

Dual Remote Cluster Controller 2 (continued)

DRCC2 configuration to identify the location of the special translations interswitched trunk.

- When a line or trunk terminates on the spouse RCC2, the RCC2 being datafilled will find the line or trunk by searching table ESAPXLA in its own ESA static data. The RCC2 can not search the memory of its spouse RCC2.
- ESA data must be updated for both RCC2s.

The following limitation and restriction applies to loading each RCC2 with ESA data: For DRCC2s, ESA data that is updated or reloaded for one RCC2 must be updated or reloaded for the interconnected RCC2.

The following limitation and restriction applies for splitting a hunt group: When a hunt group is split across two RCC2s, the search for an idle member starts with the lines in the RCC2 where the call originated. This is true even if the dialed directory number (DN) is on the originating RCC2.

The following limitations and restrictions apply to assigning interlinks:

- In a minimum configuration, port 0 of one RCC2 must be connected to port 0 of the interconnected RCC2. Port 8 of one RCC2 must be connected to port 8 of the interconnected RCC2.
- Up to 14 interlinks can be assigned, assuming minimum configuration to the host PMs.
- A port allocated for dynamic trunks cannot be assigned a C-side port unless the trunks are reconfigured.
- A port already in use as a link to the host LTC/LGC cannot be assigned unless the C-side links are reconfigured.

Dual Remote Cluster Controller 2 (continued)

The following limitations and restrictions apply to changing interconnected RCC2s:

- If a new RCC2 name is entered for field INTERRCC, the existing interconnected RCC2 is disconnected and the new RCC2 is connected. This is allowed only if the following conditions are met:
 - All existing interlinks are ManB, or at least one of the existing RCC2s of the DRCC2 is ManB or has an offline (OFFL) status.
 - None of the P-side ports of the new interconnected RCC2 entered as a port pair are already in use.

The following limitations and restrictions apply to datafilling an extension shelf:

- When datafilling DRCC2s P-side links, digital signal 1 (DS-1) and D-channel handler (DCH) links connected to the extension shelf can be datafilled only if an extension shelf was datafilled in table RCCINV.
- All links connected to the extension shelf must be changed from DS1/DCH to NILTYPE or DS30A in RCCPSINV prior to deleting the extension shelf from table RCCINV.
- Some DCH interface cards are placed in the same physical slots as the DS-1 interface cards so they cannot coexist. As a result, the following pairs of links cannot be datafilled for the same extension shelf:
 - DCH link 14 and any of the DS-1 links 24-31
 - DCH link 15 and any of the DS-1 links 32-39
 - DCH link 13 and any of the DS-1 links 40-47

Interactions

Dual Remote Cluster Controller 2 has no functionality interactions.

Activation/deactivation by the end user

Dual Remote Cluster Controller 2 requires no activation or deactivation by the end user.

Billing

Dual Remote Cluster Controller 2 does not affect billing.

Station Message Detail Recording

Dual Remote Cluster Controller 2 does not affect Station Message Detail Recording.

Dual Remote Cluster Controller 2 (continued)

Datafilling office parameters

If an RCC2 in forced ESA loses messaging to the interconnected RCC2, RSC-S_ESAENTRY_BADLINK determines how long the RCC2 in forced ESA will wait before exiting ESA and reestablishing communication with the host PM.

The following table shows the office parameters used by Dual Remote Cluster Controller 2. For more information about office parameters, refer to *Office Parameters Reference Manual*.

Office parameters used by Dual Remote Cluster Controller 2

Table name	Parameter	Explanation an action
OFCENG	RSC-S_ESAENTRY_BADLINK	Enter a value from 1 through 100. An entry of 4 equals 40 s, and an entry of 100 equals 1000 s. Default: 4.

Datafill sequence

The following table lists the tables that require datafill to implement Dual Remote Cluster Controller 2. The tables are listed in the order in which they are to be datafilled.

Datafill tables required for Dual Remote Cluster Controller 2

Table	Purpose of table
RCCINV	Remote Cluster Controller Inventory. This table contains inventory data, except P-side link assignments, for an RCC2. C-side DS-1 assignments for the RCC2 are datafilled in table RCCINV.
IRLNKINV	Interlink Inventory. Table IRLNKINV allows the operating company to configure a new DRCC2. This table references the physical configuration of interlinks between the RCC2s of a DRCC2.
RCCPSINV	Remote Cluster Controller P-side Link Inventory. This table contains only P-side link assignments for the RCC2.

Datafilling table RCCINV

Table RCCINV stores data for the remote cluster controller (RCC) node. If a configuration has an extension shelf, use this table to enter physical location data. When datafilling a tuple, the system prompts for the extension shelf fields only if an extension shelf was defined for the PM being datafilled.

Dual Remote Cluster Controller 2 (continued)

The following table shows the datafill specific to Dual Remote Cluster Controller 2 for table RCCINV. Only those fields that apply directly to Dual Remote Cluster Controller 2 are shown. Refer to the *Translations Guide* for a description of the other fields.

Datafilling table RCCINV (Sheet 1 of 2)

Field	Subfield or refinement	Entry	Explanation and action
CSLNKTAB		NILPORT	C-side link table. Use NILPORT for nonconsecutive links. Links labeled NILPORT, or not datafilled, can be used for interlinks. Note: Changes to fields with multiple entries should be made in the PROMPT mode only.
INTRASW		Y or N	Intraswitching. Enter Y if intraswitching is allowed, N if intraswitching is not allowed.
EXTSHELF		Y or N	Extension shelf. Enter N (default) if the common peripheral module (CPM) does not have an extension shelf, and Y (RCC2 only) if it does. If EXTSHELF is datafilled as Y, see the following refinements.
	EXTFR TYP	CEXT	Extension frame type. Frame type in which an extension shelf is placed. Enter CEXT for an RCC2.
	EXTFRNO	0-511	Extension frame number. Frame number of the frame type in which the extension shelf is placed.
	EXTSHPOS	0-77	Extension frame shelf position. Stores the shelf position in terms of inches from the floor.
<p>Note 1: All the links may be deleted except the message interlinks (0 and 8).</p> <p>Note 2: Changes to fields with multiple entries should be made in the PROMPT mode only. In nonprompt mode it is possible to leave out existing entries.</p> <p>Note 3: Enter the continuation mark (+) in fields with multiple possible entries when more data is specified on the next line or more records will be entered. Enter the end mark (\$) in fields with multiple possible entries after the last entry.</p> <p>Note 4: When datafilling field C-side link table (CSLNKTAB), assure message links are not assigned to the same physical interface card. When the interface card supports two or more links, separate the message links by the number of links on the interface cards. This applies to all interface link types; DS-1, DS30, DS30A, or PCM-30. Table control will issue a warning if an attempt is made to assign message links on the same interface card. Assigning message links to the same interface card can cause an E1 outage (failure of all message links) if the card fails.</p>			

Dual Remote Cluster Controller 2 (continued)

Datafilling table RCCINV (Sheet 2 of 2)

Field	Subfield or refinement	Entry	Explanation and action
	EXTFLOOR	0-99	Extension frame floor. Indicates the floor of the building where an extension shelf is located.
	EXTROW	0-99	Extension frame row. The row where an extension shelf is located.
	EXTFRPOS	0-99	Extension frame position. Position in a frame.
	EXTEQPEQ	alphanumeric	Extension frame equipment PEC. Product engineering code (PEC) for an extension shelf. Enter MX86AA.
	EXTSIDE	L and R	Extension frame side. Specifies which half of a physical shelf houses the logical extension shelf. Enter L or R.
<p>Note 1: All the links may be deleted except the message interlinks (0 and 8).</p> <p>Note 2: Changes to fields with multiple entries should be made in the PROMPT mode only. In nonprompt mode it is possible to leave out existing entries.</p> <p>Note 3: Enter the continuation mark (+) in fields with multiple possible entries when more data is specified on the next line or more records will be entered. Enter the end mark (\$) in fields with multiple possible entries after the last entry.</p> <p>Note 4: When datafilling field C-side link table (CSLNKTAB), assure message links are not assigned to the same physical interface card. When the interface card supports two or more links, separate the message links by the number of links on the interface cards. This applies to all interface link types; DS-1, DS30, DS30A, or PCM-30. Table control will issue a warning if an attempt is made to assign message links on the same interface card. Assigning message links to the same interface card can cause an E1 outage (failure of all message links) if the card fails.</p>			

Datafill example for table RCCINV

The following examples show sample datafills for table RCCINV for both an RCC2 provisioned with the NTMX77AA UP and an RCC2 provisioned with the optional NTAX74AA CAP, respectively.

Dual Remote Cluster Controller 2 (continued)

MAP display example for table RCCINV datafilled for NTMX77AA UP

```

Table: RCCINV
RCCNAME      FRTYPE FRNO SHPOS FLOOR ROW FRPOS  EQPEC  LOAD
-----
CARY RCC2 0
      1101 CRSC  0    5    0    C    0      MX85AA  CRI08xx
EXECTAB
-----
(POTS POTSEX) (KEYSET KSETEX) (RMM_TERM RSMEX) (ESALINES ESAEX) $

CSPM          CSLNKTAB
-----
LTC 1         (0) (1) (2) (3) (4) (5) (6) (7)
ESA INTRASW  OPTCARD  CMRLOAD  CONTMARK
-----
Y   Y (UTR6) (NT7X05AA 7) (MSG6X69) (CMR5 CMRAG03) (ISP16) $
TONESET PECS6X45 E2LOAD  EXTINFO
-----
NORTHAM  MX77AA  MX77AA  MX77xxxx  CEXT 0 4 0 E 15 MX86AA L

```

Note 1: xx in field LOAD and xxxx in field E2LOAD represent alphanumeric entries, for example B1 and XE01, respectively.

Note 2: If the shelf is equipped with a processor other than NTMX77 or the optional NTAX74, field E2LOAD is automatically datafilled with value NILLOAD.

Note 3: NTMX77 UP is required to support NT7X05 functionality. The optional NTAX74 CAP does not support NT7X05 PRL functionality. When a user attempts to datafill field PECS6X45 with AX74AA AX74AA instead of MX77AA MX77AA when NT7X05 is already datafilled as an optional card, the tuple change is disallowed and the MAP displays the following message:

Info: NT7X05AA requires MX77 processor

Note: When field PECS6X45 is datafilled with AX74AA AX74AA instead of MX77AA MX77AA, the load name prefix in field LOAD changes from CRI to XRI. For example, CRI08xx (for MX77) changes to XRI08XX (for AX74AA). The following example shows sample datafill for table RCCINV when the RCC2 is datafilled for the NTAX74AA CAP.

Dual Remote Cluster Controller 2 (continued)

MAP display example for table RCCINV datafilled for NTAX74AA CAP

```

Table: RCCINV
RCCNAME      FRTYPE FRNO SHPOS FLOOR ROW FRPOS  EQPEC  LOAD
-----
CARY RCC2 0
  1101      CRSC  0   5   0   C   0   MX85AA  XRI08xx
EXECTAB
(POTS POTSEX) (KEYSET KSETEX) (RMM_TERM RSMEX) (ESALINES ESAEX) $
CSPM        CSLNKTAB
LTC 1      (0) (1) (2) (3) (4) (5) (6) (7)  $
ESA INTRASW  OPTCARD      CMRLOAD      CONTMARK
Y   Y      (UTR6) (MSG6X69)      (CMR5 CMRAG03) (ISP16)  $
TONESET    PECS6X45      E2LOAD      EXTINFO
NORTHAM    AX74AA  AX74AA      AX74xxxxx  CEXT 0 4 0 E 15 MX86AA L

```

Error messages for table RCCINV

The following error messages apply to table RCCINV.

Error messages for table RCCINV (Sheet 1 of 2)

Error message	Explanation and action
PORT n EQUIPPED AS INTERLINK	The user attempted to equip a P-side link on a port that has been configured as an interlink port.
DELETE DUAL CONFIGURATION	The user attempted to delete an RCC2 that is part of a DRCC2. Detach the interconnected RCC2 by using tables RCCINV and IRLNKINV.
Delete pslinks prior to deleting the extension.	The user attempted to delete an extension shelf that has P-side links datafilled in table RCCPSINV.
Extension pec must be MX86AA.	The user attempted to datafill a PEC other than MX86AA to the extension shelf.

Dual Remote Cluster Controller 2 (continued)

Error messages for table RCCINV (Sheet 2 of 2)

Error message	Explanation and action
XX does not support extension.	The user attempted to add an extension shelf to a non-CPM peripheral (where XX is the peripheral's PM type).
Info: NT7X05AA requires MX77 processor	A user has attempted to datafill field PECS6X45 with AX74AA AX74AA instead of MX77AA MX77AA when NT7X05 is already datafilled as an optional card.

Datafilling table IRLNKINV

The RCC2 interlinks are P-side links, unlike other RCC types where the interlinks are C-side links. To accommodate this characteristic, the interlink range values are increased in order to enable all range of RCC2 DS-1 P-side links, the interlink values are datafilled in field IRLNKTAB in this table.

The tuple of table IRLNKINV is added automatically when the peripheral is defined in table RCCINV. Before the RCC2's tuple in IRLNKINV is changed, the P-side links must be defined as DS-1 in table RCCPSINV.

The following table shows the datafill specific to Dual Remote Cluster Controller 2 for table IRLNKINV. Only those fields that apply directly to Dual Remote Cluster Controller 2 are shown. Refer to the *Translations Guide* for a description of the other fields.

Datafilling table IRLNKINV (Sheet 1 of 2)

Field	Subfield or refinement	Entry	Explanation and action
RCCNAME		see subfields	RCC2 name. Subfields: SITE, PMTYPE, and RCCNO.
	SITE	alphanumeric	Site. The name assigned to the remote location. This entry should appear in table SITE.
	PMTYPE	RCC2	Peripheral module type. The PM type is RCC2.
<p>Note 1: Changes to fields with multiple entries should be made in the PROMPT mode only. In nonprompt mode it is possible to leave out existing entries.</p> <p>Note 2: Enter the continuation mark (+) in fields with multiple possible entries when more data is specified on the next line or more records will be entered. Enter the end mark (\$) in fields with multiple possible entries after the last entry.</p>			

Dual Remote Cluster Controller 2 (continued)

Datafilling table IRLNKINV (Sheet 2 of 2)

Field	Subfield or refinement	Entry	Explanation and action
INTERRCC	RCCNO	0-255	RCC2 number. The external number assigned to the RCC2. Enter a value from 0-255.
		see subfields	Interconnected RCC2. The name of the interconnected RCC2. Subfields: SITE, PMT, and RCCNO.
	SITE	alphanumeric	Site. The name assigned to the remote location. This entry should appear in table SITE.
	PMT	RCC2	Peripheral module type. The PM type is RCC2.
IRLNKTAB	RCCNO	0-255	RCC2 number. The external number assigned to the RCC2. Enter a value from 0-255.
		see subfields	Interlink table. This field contains from 2 to 14 port pairs for the interlinks of the DRCC2. Subfields: RCC1_PORT and RCC2_PORT.
	RCC1_PORT	numeric	Port number of the RCC2 1 interlink. NILPORT indicates the link is not connected. It is used to disconnect an interlink. Enter a value from 0-47 or NILPORT for an RCC2 with an extension shelf. Enter a value from 0-21 or NILPORT for an RCC2 without an extension shelf.
IRLNKTAB (continued)	RCC2_PORT	numeric	The port number of the RCC2 2 interlink. NILPORT indicates the link is not connected. It is used to disconnect an interlink. Enter a value from 0-47 or NILPORT for an RCC2 with an extension shelf. Enter a value from 0-21 or NILPORT for an RCC2 without an extension shelf.
ESAFORCE		Y or N	Forced ESA. Enter Y to allow the RCC2 to enter forced ESA when the interconnected RCC2 enters ESA. Otherwise, enter N. Default: N.
<p>Note 1: Changes to fields with multiple entries should be made in the PROMPT mode only. In nonprompt mode it is possible to leave out existing entries.</p> <p>Note 2: Enter the continuation mark (+) in fields with multiple possible entries when more data is specified on the next line or more records will be entered. Enter the end mark (\$) in fields with multiple possible entries after the last entry.</p>			

Dual Remote Cluster Controller 2 (continued)

Datafill example for table IRLNKINV

The following example shows sample datafill for table IRLNKINV.

MAP display example for table IRLNKINV

RCCNAME	INTERRCC	IRLNKTAB

ESAFORCE		

RAL5 RCC 11	RAL6 RCC 12	
(1 1) (3 3)	(9 9) (11 11)	(12 12) (13 14) \$
Y		

Error messages for table IRLNKINV

The following error messages apply to table IRLNKINV.

Error messages for table IRLNKINV (Sheet 1 of 2)

Error message	Explanation and action
STATIC DATA HAS CHANGED, BSY & RTS BOTH RCC2s	A new DRCC2 has been configured, or interlink assignments of an existing DRCC2 have been changed. Busy and return the inactive unit to service, and SWACT the RCC2 (for both RCC2s of the DRCC2).
PORT n IS EQUIPPED AS C-side LINK	A port <i>n</i> entered as an interlink is already equipped as a C-side link and is not available for an interlink.
DELETE COMMAND NOT ALLOWED, USE THE CHANGE COMMAND	The DELETE command was issued when in the table IRLNKINV. Use the CHANGE command to delete an interlink.
OLD PORT n ON HOST IS NOT MANBSY	An attempt is made to delete a link that is in service.
INVALID C-SIDE LINK RELOCATE NODE FAILED	An attempt is made to delete a link and its subsequent link is in service.
Max port range for RCC2 & SRCC is 23	The user attempted to datafill a port number greater than 23 in fields RCC1_PORT or RCC2_PORT for the RCC2.

Dual Remote Cluster Controller 2 (continued)

Error messages for table IRLNKINV (Sheet 2 of 2)

Error message	Explanation and action
Max port range for RCC2 & SRCC is 47 when extension is defined	The user attempted to datafill a port number greater than 47 in fields RCC1_PORT or RCC2_PORT for the RCC2 with an extension.
Port number for RCC & RCCI is 0-15, NILPORT	The user attempt to datafill a port number greater than 15 in fields RCC1_PORT or RCC2_PORT for a non-RCC2.

Datafilling table RCCPSINV

Table Remote Cluster Controller P-side link Inventory (RCCPSINV) contains only the P-side link assignments for the DRCC2s. Up to 54, 0-53, multiples of P-side link information may be datafilled for the RCC2. When an extension shelf is added, there are datafill restrictions for P-side links connected to the extension shelf.

When datafilling the P-side links in this table for DRCC2s, the DS-1 and DCH links connected to the extension shelf can be datafilled only if an extension shelf was datafilled in table RCCINV. All the links connected to the extension shelf must be changed from DS-1/DCH to NILTYPE or DS30A in RCCPSINV prior to deleting the extension shelf from table RCCINV.

Some of the DCH interface cards are placed in the same physical slots as the DS-1 interface cards so they cannot coexist. As a result, the following pairs of links cannot be both datafilled for the same extension shelf:

- DCH link 14 and any of the DS-1 links 24-31
- DCH link 15 and any of the DS-1 links 32-39
- DCH link 13 and any of the DS-1 links 40-47

Other than the restrictions applied the extension shelf, there are no changes to table RCCPSINV for DRCC2s. Refer to the *Translations Guide* for a description of the other fields.

Dual Remote Cluster Controller 2 (end)

Error messages for table RCCPSINV

The following error messages apply to table RCCPSINV.

Error messages for table RCCPSINV

Error message	Explanation and action
Cannot datafill &\$ in link &\$	P-side link restrictions for RCC2 prevent datafill (for example, if the first parameter is the link type and the second parameter is the link number).
DS-1 not allowed on link &\$ when DCH datafilled on link &\$	P-side link restrictions for RCC2 prevent datafill.
DS-1 not allowed in link # when there is no extension shelf	The user attempted to datafill a DS-1 link to the extension shelf when no extension shelf has been datafilled.
DCH not allowed in link # when there is no extension shelf	The user attempted to datafill a DCH link to the extension shelf when no extension shelf has been datafilled.
DS-1 not allowed in link # when DCH is in link #	The user attempted to datafill a DS-1 link with a card position in the same physical slot as the DCH card of the DCH already datafilled.

Translation verification tools

Dual Remote Cluster Controller 2 does not use translation verification tools.

SERVORD

Dual Remote Cluster Controller 2 does not use SERVORD.

ISDN operations

Functional group

NI000007

Feature package

NTX750AD ISDN Basic Access

Release applicability

BCS35 and up

Prerequisites

To operate, ISDN operations requires the following feature packages:

- NTX145AA Remote Switching Center
- NTX150AA RSC-intra RSC Calling
- NTXP92AA Remote Switching Center Basic
- NTXR42AA Firmware Downloading
- NTX000AA Bilge
- NTX001AA Common Basic
- NTX100AA Integrated Business Networks-Basic (IBN)
- NTX108AA IBN-Display Features
- NTX142AA DS-1 64 kb/s Clear
- NTX269AA Universal Tone Receivers (Domestic)
- NTX270AA New Peripheral Maintenance
- NTX901AA Local Features I

Description

Understanding certain terms and concepts will help you datafill the Digital Multiplex System (DMS) so that ISDN terminals off of the RCC2 can communicate with the exchange termination and the packet handler.

Note: Many of these concepts are explained in *Translations Guide* and *ISDN Operations, Administration, and Maintenance System Description Reference Manual*.

Profile of a basic rate interface line

The term basic rate interface (BRI) is used to indicate a type of ISDN service.

ISDN operations (continued)

The key attributes of an ISDN line are that there are multiple devices off of each line equipment number (LEN) and that devices are considered to be logical terminals (LT). To identify these terminals, the following concepts are used: logical terminal identifier (LTID), terminal endpoint identifier (TEI), call appearances and feature appearances, and access privileges (AP).

Logical terminal identifier

The LTID provides a unique LT, or profile, to the exchange termination (ET). It consists of the following:

- LT group (LTGRP) which is the name of the group of LTs (up to 32)
- LT number (LTNUM) which is the number that identifies the LT within the group (1 through 1022)

Terminal endpoint identifier

The TEI uniquely identifies the physical terminals on the same group. The Consultative Committee on International Telegraphy and Telephony (CCITT) has defined a maximum of 128 TEIs for each ISDN loop. However, NT allows a maximum of eight TEIs defined per loop, with TEI 1 and 2 assigned to devices associated with BRI B-channels and TEI 21 through 26 assigned to devices with BRI D-channels.

In summary, a BRI ISDN line has up to two B-channels, 8 LTIDs, and 8 TEIs. Note that a physical terminal can have more than one LT.

Call appearances and feature appearances

Terminals off of an ISDN line can support multiple directory numbers (DN) and various features on programmable keys and softkeys. The Meridian M5317 Digital telephone supports the following:

- call appearances (CAP), which are directory numbers assigned to the M5317
- feature appearances (FAP), which are features assigned to the M5317

Access privileges

Once an LT has been defined, it is associated with a LEN and TEI for the BRI. Once the LEN and TEI are associated, the physical terminal connected to the ISDN interface is able to originate and receive calls.

Depending on how they are datafilled, terminals can have the following AP:

- voice and circuit-switched data on a B-channel (B)
- low-speed packet-switched data on a D-channel (D)

ISDN operations (continued)

- high-speed packet data on a B-channel (PB)
- combined circuit-switched and D-channel packet data (BD)

The types of services accessible to an LT are defined by the LT AP, which is usually defined through service order software subsystem (SERVORD) commands. The following figure shows how the attributes of datafill determine AP. The next figure shows the APs available and the values entered using SERVORD.

Attributes for determining access privileges

Access privilege	Description	Circuit switching (Y or N)	Packet switching (N, D, or B)
B	circuit-switched voice and data	Y	N
D	packet-switched voice and data	N	D
PB	packet-switched high-speed data	N	B
BD	voice and low-speed packet data	Y	D

Note: If a device can carry both low and high-speed data, two LTIDs are required since there are two profiles.

ISDN operations (continued)

The example shows available AP and attribute values entered using SERVORD.

Attributes of datafill according to AP

	CPE	DMS	DPN
B	TEI	LTD, AP of B LEN/TEI CAP (DN) FAP (options and features)	No attributes required
D	TEI Packet parameters for LAPDX25 DNA L2 and L3	LTID, AP of D LEN/TEI/DCHCHNL	DIU/TIM/SIM/AM/PI/PO LTID Packet parameters for LAPDX25 • DNA • L2 and L3 Options and features
BD	TEI (phone and PC) Packet parameters for LAPDX25 DNA L2 and L3	LTID, AP of BD LEN/TEI/DCHCHNL CAPs (DN) FAPs (options and features)	DIU/TIM/SIM/AM/PI/PO LTID Packet parameters for LAPDX25 • DNA • L2 AND L3 Options and features
PB	Channel (B1 and B2) Packet parameters for LAPB25 • DNA • L2 and L3	LTID, AP of PB LEN/Bch DS-1/DS-0 (nailed up)	DIU/TIM/SIM/AM/PI/PO Packet parameters for LAPBX25 • DNA • L2 and L3

Operation

Datafill for the RCC2 can be described in terms of physical configuration, service capabilities, and bearer capabilities.

ISDN operations (continued)

Defining the physical configuration

The following translations tables identify hardware components and the connections between them.

Hardware components

The following tables define physical RCC2 configuration components:

- LTCINV (Line Trunk Inventory)
- LTPSINV (Line Trunk Peripheral Side Inventory)
- RCCINV (RCC Inventory)
- RCCPSINV (RCC Peripheral-Side Inventory)
- LCMINV (Line Concentrating Module Inventory)
- RMMINV (Remote Maintenance Module Inventory)

DS-1 and trunk data

The following tables define names and attributes of the links between the components of the RCC2 configuration:

- CLLI (Common Language Location Identifier)
- TRKGRP (Trunk Group)
- TRKSGRP (Trunk Subgroup)
- TRKMEM (Trunk Member)
- CARRMTC (Carrier Maintenance)
- PADATA (Pad Data)

D-channel data

The following tables define D-channel data:

- SPECCONN (Special Connections)
- DCHINV (D-channel Handler Inventory)

Alarm components

The following tables set points that are used to report alarms:

- ALMSCGRP (Alarm Scan Group)
- ALMSDGRP (Alarm Signal Distributor Group)

ISDN operations (continued)

Testing components

The following tables are used to set up test facilities:

- MTAMDRVE (Metallic Test Access Minibar Driver)
- MTAMVERT (Metallic Test Access Vertical Connection)
- MTAMHORIZ (Metallic Test Access Horizontal Connection)

Defining service capabilities

These tables contain BRI attributes. Note that many of these tables are filled automatically using SERVORD.

- LTGRP (Logical Terminal Group)
- LTDEF (Logical Terminal Definition)
- LTMAP (Logical Terminal Map)
- KSETINV (Keyset Inventory)
- KSETLINE (Keyset Line)
- KSETFEAT (Keyset Features)

Translations table flow

The ISDN operations translation tables are described in the following list:

- Table MTAHORIZ lists the assignment of horizontal agents to a horizontal of a horizontal group of MTAMs. Table MTAHORIZ uses CLLI codes from table CLLI for host and remote line test units, metallic test units (multiline), operator verification trunks, metallic jacks (MJACK) and incoming test access trunks. Field EXTRKNM in this table is the external trunk number assigned to the line test unit or the metallic test unit. The EXTRKNM entry must correspond to an entry in table TRKMEM in field EXTRKNM.
- Table MTAVERT identifies the vertical connectivity to the MTA matrix. For RSC-S, the connection is single rather than multiple. Field SITE in table MTAVERT must correspond to field NAME in table SITE to identify the equipment for the switching unit and for all remote locations that home on to it.
- Table MTAMDRVE locates an MTAM driver in the MTA structure. MTA is used to connect test equipment to a circuit that requires testing. The metallic test access (MTA) network is a matrix of vertical and horizontal crosspoints, comparable to a minibar, that connect specified verticals to horizontal within the network.
- Table KSETFEAT associates feature appearances (ISDN logical terminal [LT] feature activators and indicators) with feature instances and various

ISDN operations (continued)

feature options. The LTID tuple in table KSETFEAT corresponds to the KSETLEN tuple in table KSETINV.

- Table LTMAP maps the ISDN LTs to a LEN or the TEI, depending on the access privilege (AP). AP data corresponds to the LTKEY tuple in table LTDEF. Table LTMAP uses the LEN tuple (originally datafilled in table LNINV) to access data for each line card slot. Field SCSEL in this table corresponds to the OPTION tuple in table SPECCONN.
- Table KSETLINE associates call appearances (ISDN LT call activators and indicators) to directory numbers and various feature options. The LTID tuple in table KSETLINE corresponds to the KSETLEN tuple in table KSETINV.
- Table KSETINV identifies an LTID as an ISDN keyset and defines its attributes. The KSETLEN tuple in table KSETINV contains the LTID tuple.
- Table SPECCONN contains connections that cannot be modified using SERVORD. Field SITE in table SPECCONN corresponds to the NAME tuple from table SITE to identify the equipment for the switching unit and for all remote locations that home on to it. Table SPECCONN also duplicates datafill of the XPMNO and XPMTYPE tuples in table LTCPSINV to access the assignment of the peripheral side (P-side) links. The OPTION tuple in this table corresponds to field SCSEL in table LTMAP.
- Table LTDEF defines ISDN terminals and AP for the type of service the terminal can access. Field LTDEF in this table identifies an ISDN LT group. This field corresponds to field GROUP in table LTGRP.
- Table LNINV lists the data for each line card slot. The LEN tuple in table LNINV corresponds to the LEN tuple in table LTMAP.
- Table ALMSC identifies the function to be performed by each of the assigned scan points in the alarm scan groups. Field SCGROUP identifies a scan group number and corresponds to the SCGROUP entry in table ALMSCGRP.
- Table ALMSD identifies the function to be performed by each of the assigned signal distribution points in the alarm signal distributor groups. Field SDGROUP identifies the circuit equipment, location, and type of circuit card containing signal distribution (SD) points. Field SDGROUP corresponds to an entry in table ALMSDGRP.
- Table ALMSDGRP records the circuit equipment, location, and type of circuit card containing signal distribution (SD) points. Datafill in field SDGROUP in table ALMSD should correspond to SDGROUP entries in table ALMSDGRP.

ISDN operations (continued)

- Table ALMSCGRP records the circuit equipment, location, and type of circuit card containing scan points. Datafill in field SCGROUP in table ALMSC should correspond to SCGROUP entries in table ALMSCGRP.
- Table TRKMEM lists the data associated with each trunk assigned to one of the trunk groups and subgroups specified in tables TRKGRP and TRKSGRP. This table identifies circuits associated with static trunks, dynamic trunks, and test equipment used to test lines and trunks. Field CLLI in table TRKMEM corresponds to the trunk group CLLI code.
- Table TRKSGRP lists the supplementary information for each subgroup that is assigned to one of the trunk groups listed in table TRKGRP. Field CLLI in table TRKSGRP corresponds to the trunk group CLLI code.
- Table ISTRKGRP controls the dynamic nature of the trunks located on an RCC2. An entry in this table indicates a trunk group has dynamic capability. Subfield SITE_NM in table ISTRKGRP identifies equipment for the switching unit and for all remote locations that home on to it. Subfield SITE_NM corresponds to field NAME in table SITE. Field CLLI in table ISTRKGRP corresponds to the trunk group CLLI code.
- Table TRKGRP defines data for each trunk group associated with the switching unit. Field CLLI in table TRKGRP corresponds to the trunk group CLLI code.
- Table LTGR provides the capacity to define up to 32 LT groups. One of the groups is defined as ISDN. Field GROUP in table LTGRP corresponds to field LTGRP in table LTDEF.
- Table RMMINV identifies a remote RLCM, RSC-S, or Outside Plant Module (OPM) site with the frame type, frame number, floor, row, frame position, product engineering code (PEC), PM load and executive program loaded, and central side (C-side) PM attached to each remote maintenance module (RMM).

Subfield SITENM in table RMMINV corresponds to the NAME field in table SITE. This field identifies the equipment for the switching unit and for all remote locations that home on to it. Field LOAD in table RMMINV corresponds to the LOADNAME tuple from table PMLOADS. This field stores the device location of each PM load file.
- Table ISGDEF contains the service and channels information for the PM supporting the DCH. Field in table ISGDEF isolates the DCH card and the PM that houses it. Fields PMTYPE and PMNO and subfield D_CHNL corresponds to the PMTYPE, PMNO, and DCHNO tuples in table DCHINV. The ISGNO tuple in table ISGDEF corresponds to the ISGNO tuple in table SPECCONN.
- Table DCHINV contains information about the D-channel handler (DCH) for those peripherals that contain this card. The PMTYPE, PMNO, and

ISDN operations (continued)

DCHNO tuples correspond to the PMTYPE and PMNO fields and subfield D_CHNL in table ISGDEF.

- Table LCMINV lists data assignment for each bay associated with a local line concentrating module (LCM) or Remote Line Concentrating Module (RLCM) unit. Field SITE in table LCMINV corresponds to the NAME tuple from table SITE. This field identifies equipment for the switching unit and for all remote locations that connect to it. Field LOAD field in table LCMINV corresponds to the LOADNAME tuple from table PMLOADS. This field stores the device location of each PM load file.
- Table RCCPSINV contains only RCC2 P-side link assignments. When a tuple is added in table RCCINV, a corresponding tuple is added automatically in table RCCPSINV. Field CARRIDX indexes into table CARRMTC for maintenance control information about peripheral. Also, the RCCNAME tuple in table RCCPSINV corresponds to the RCCNAME tuple from table RCCINV and stores site information (originally entered in field NAME from table SITE) the PM type, and PM number.
- Table RCCINV maintains a list of RCC2s datafilled in the DMS system and contains RCC2 inventory data (except P-side link assignments). The table information identifies where the RCC2 is located, load and exec lineups required, and network link connections. RCC2 C-side DS-1 assignments and intraswitching are datafilled in table RCCINV.

Load information for this table is datafilled in field LOAD and corresponds to the LOADNAME tuple from table PMLOADS. Also, the RCCNAME tuple in table RCCINV corresponds to the RCCNAME tuple from table RCCPSINV. Field RCCNAME stores site information (originally entered in the NAME field from table SITE), the PM type, and PM number.

- Table LTCPSINV contains the assignment of PM P-side links. If DS-1 is datafilled in AREASELCT, field CARRIDX indexes table CARRMTC for maintenance control information about the peripheral.

Field XPMNO in table LTCPSINV corresponds to field PMNO in table SPECCONN. Also, field XPMTYPE corresponds to field PMTYPE in table SPECCONN.

- Table CARRMTC allows the DMS switch administration to datafill maintenance control information in peripherals, out-of-service limits for alarms, and system return-to-service (RTS) occurrences. The TMPLTNM tuple in table CARRMTC corresponds to the field CARRIDX in tables LTCPSINV and RCCPSINV.
- Table LTCINV contains the inventory data, except the P-side link assignment, for PM types. This table is used to define the line trunk controller (LTC)/line group controller (LGC) on the C-side of the RCC2.

ISDN operations (continued)

Load information for this table is datafilled in field LOAD and corresponds to the LOADNAME tuple from table PMLOADS.

Field LTCNAME in table LTCINV corresponds to the LTCNAME field in table LTCPSINV.

- Table PMLOADS stores the device location of every peripheral module (PM) load file in order to map between the load names and devices on which the loads reside. The PM load files must be datafilled in table PMLOADS before they can be used in the inventory tables.

Load information is datafilled in field LOADNAME and corresponding entries are datafilled in field LOAD for tables LTCINV, LCMINV, and RMMINV.

- Table SITE identifies the equipment for the switching unit and for all remote locations that home on to it. This table must be datafilled before any LEN can be assigned or a PM can be datafilled. The host switching unit is the first entry in this field, then field NAME is associated with the number required to dial the site, and alarm data for remote sites. Table SITE uses the same CLLI tuple for operator verification as the one datafilled in table CLLI.

Field SITE in table LCMINV, field SITENM in tables RCCINV and RMMINV, and subfield SITE_ID in table ISTRKGRP must be known to table SITE (field NAME).

- Table CLLI uniquely identifies far end of the trunk group by the name of the city or town, the state or province, the building group, the destination of the traffic unit and the code identifying trunk groups that terminate at the same CLLI location. Table CLLI also stores the maximum number of trunk groups expected to be assigned to the trunk group and a miscellaneous entry for administrative information not used by the switching unit.

Some CLLI codes are added automatically to table CLLI when the feature is present in the switch. Other codes must be added to the CLLI table. After datafilling table CLLI, CLLI codes are reflected in trunk group tables, scan and distribution point table, and MTA tables. The CLLI tuple for operator verification must be duplicated in field OPVRCLLI in table SITE.

- Table DATASIZE specifies the size of certain tables. For BRI services, table DATASIZE must be datafilled to specify the size needed for table SPECCONN. If the size is not set high enough, table SPECCONN will be corrupted.

Table DATASIZE is datafilled initially with default table size values for RSC-S tables CLLI, SPECCONN, TRKGRP, and TRKSGRP.

ISDN operations (continued)

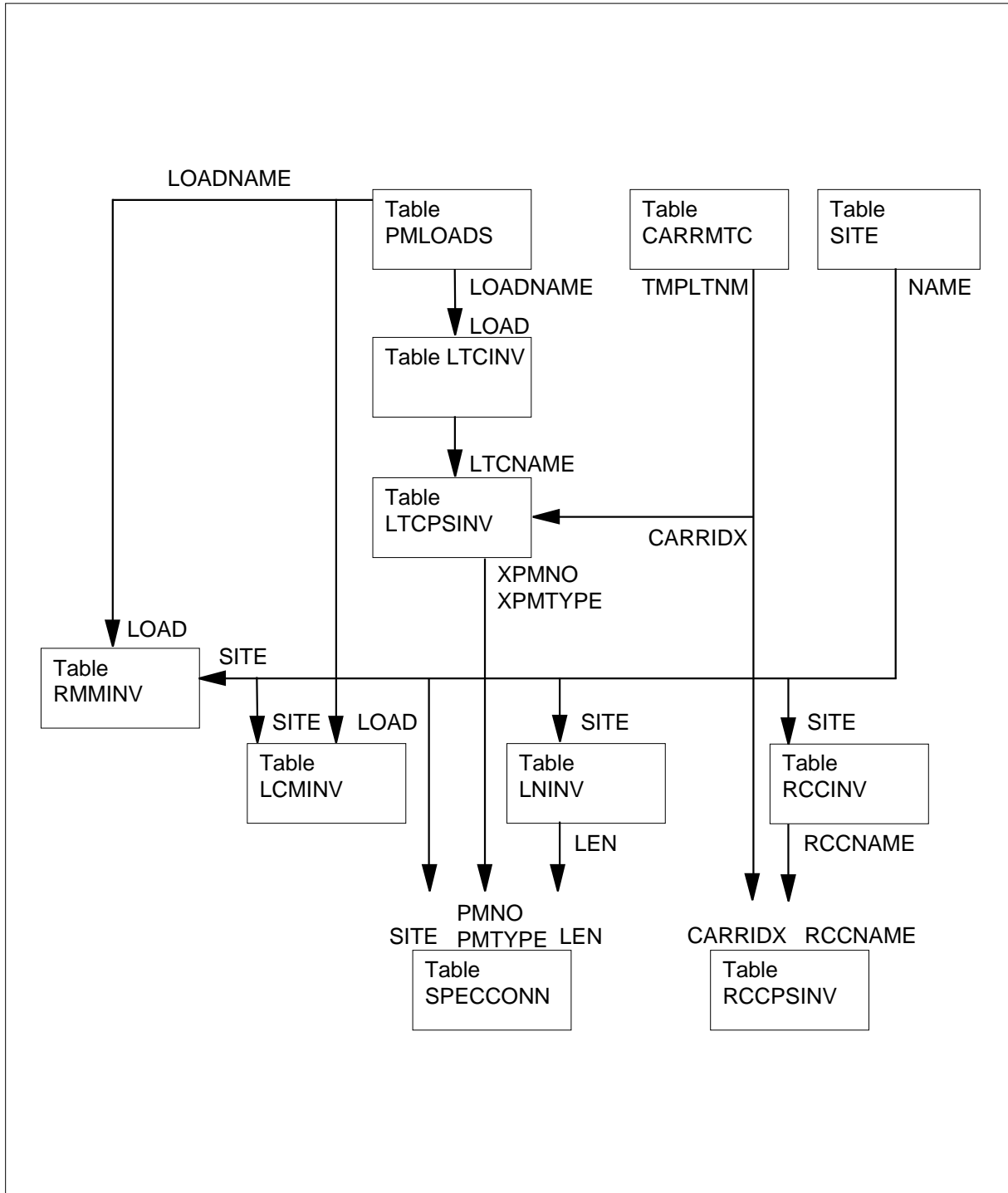
Note: Some data tables must be datafilled according to the kind of trunk group type required. Each trunk group type requires a specific form. The valid trunk group types are TI, TO, T2, IBNTI, IBNTO, IBNT2, PX, and ES.

The following flowcharts show the ISDN operations translations process.

Note: The tables that are enclosed within the dotted lines are datafilled through SERVORD and not through the table editor.

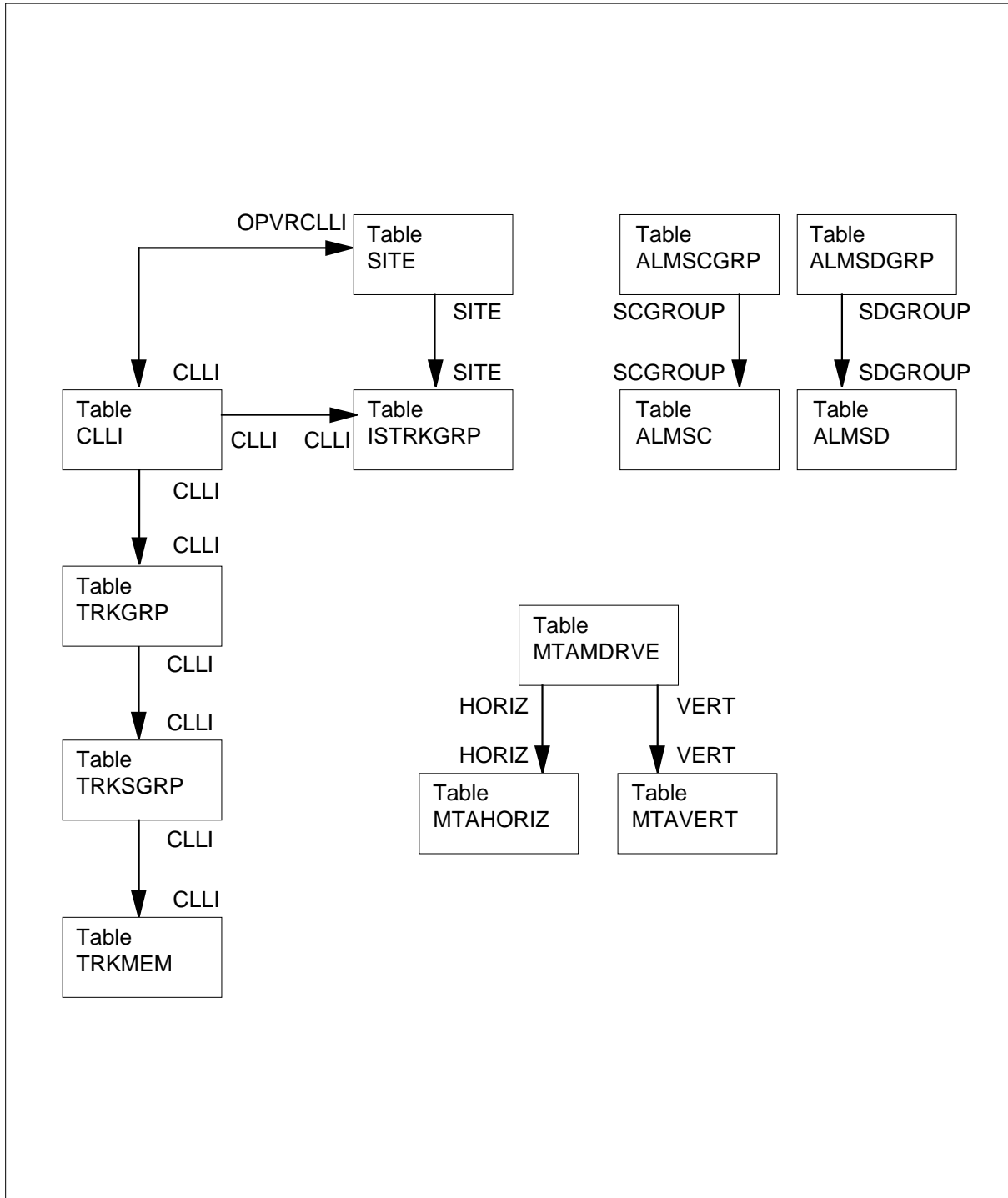
ISDN operations (continued)

Table flow for ISDN operations



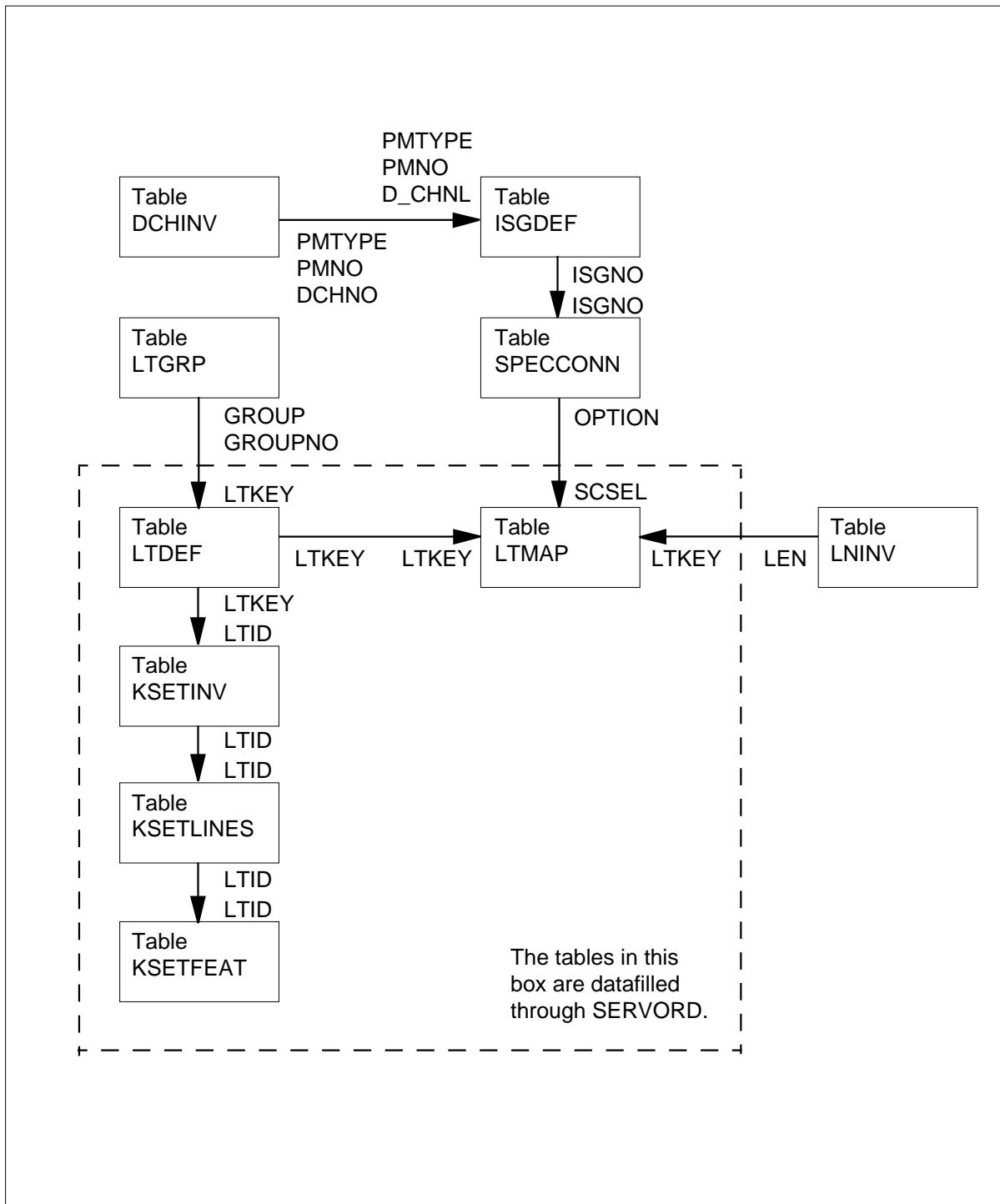
ISDN operations (continued)

Table flow for ISDN operations (continued)



ISDN operations (continued)

Table flow for ISDN operations (continued)



ISDN operations (continued)

Limitations and restrictions

ISDN operations has no limitations or restrictions.

Interactions

ISDN operations has no functionality interactions.

Activation/deactivation by the end user

ISDN operations requires no activation or deactivation by the end user.

Billing

ISDN operations does not affect billing.

Station Message Detail Recording

ISDN operations does not affect Station Message Detail Recording.

Datafilling office parameters

There are parameters that are specific to the RSC-S with ISDN configuration.

Datafill sequence

The following table lists the tables that require datafill to implement ISDN operations. The tables are listed in the order in which they are to be datafilled.

Datafill tables required for ISDN operations on RSC-S (Sheet 1 of 4)

Table	Purpose of table
DATASIZE	Data Size. This table specifies the size of certain tables. For CSP02 and up, tuple SPECCONN is no longer required in table DATASIZE and a restart is no longer required to increase the table size. Prior to CSP02, to extend the length of table SPECCONN, increase the size in table DATASIZE and do a restart.
CLLI	Common Language Location Identifier. Uniquely identifies the far end of each announcement, tone, trunk group, test trunk, national milliwatt test lines, and service circuit.
SITE	Site. Contains data that allows the DMS system to recognize the equipment for the switching unit and for remote locations that home on to it.
PMLOADS	Peripheral Module Loads. Stores the device location of every peripheral module (PM) load file in order to map between the load names and devices that the loads reside on. This permits autoloading to locate load files without the intervention of personnel. The expanded peripheral module (XPM) load files must be datafilled in table PMLOADS before they can be used in the XPM inventory tables.

ISDN operations (continued)**Datafill tables required for ISDN operations on RSC-S (Sheet 2 of 4)**

Table	Purpose of table
LTCINV	Line Trunk Controller Inventory. Contains the inventory data, except the P-side link assignment, for PM types. This table is used to define the line trunk controller (LTC)/line group controller (LGC) on the C-side of the RCC2.
CARRMTC	Carrier Maintenance Control. Allows DMS switch administration to datafill maintenance control information in peripherals, out-of-service limits for alarms, and system return-to-service (RTS) occurrences.
LTCPSINV	Line Trunk Controller P-side link Inventory. Contains the assignment of the P-side links for XPM-type peripherals.
RCCINV	Remote Cluster Controller Inventory. Contains inventory data (except P-side link assignments) for the RCC2. C-side DS-1 assignments for the RCC2 are datafilled in table RCCINV.
RCCPSINV	Remote Cluster Controller P-side link Inventory. Contains only the P-side link assignments for the RCC2.
LCMINV	Line Concentrating Module Inventory. Lists data assignments for each bay associated with a local LCM or RLCM unit.
DCHINV	D-Channel Inventory. Contains information about the D-channel handler (DCH). Information includes the DCH ID number (unique for each DCH), the name and number of the host PM and the associated NTMX81 port, NTB02AA (the PEC), the load file, and the port number.
ISGDEF	ISDN Service Group Definition. Contains the service and channels information for the PM supporting the DCH.
RMMINV	Remote Maintenance Module Inventory. Identifies an RLCM, RSC-S, or OPM site with the frame type, frame number, floor, row, frame position, PEC code, PM load and executive program loaded, as well as the C-side PM attached to each remote maintenance module (RMM).
LNINV	Line Circuit Inventory. Lists the data for each line card slot.
LTGRP	Logical Terminal Group. Provides the capacity to define up to 32 LT groups. One of the groups is defined as ISDN.
TRKGRP	Trunk Group. Defines data for each trunk group associated with the switching unit.
ISTRKGRP	ISTRKGRP (RCC Dynamic Trunk Groups Table Record). Controls the dynamic nature of the trunks located on an RCC2. An entry in this table indicates that a trunk group has dynamic capability.

ISDN operations (continued)**Datafill tables required for ISDN operations on RSC-S (Sheet 3 of 4)**

Table	Purpose of table
TRKSGRP	Trunk Subgroup. Lists supplementary information for each subgroup that is assigned to one of the trunk groups listed in table TRKGRP.
TRKMEM	Trunk Member. Lists data associated with each trunk assigned to one of the trunk groups and subgroups specified in tables TRKGRP and TRKSGRP. This table identifies the circuits associated with static trunks, dynamic trunks, and the test equipment used to test lines and trunks.
ALMSCGRP	Alarm Scan Group. Records the circuit equipment, location, and type of circuit card containing scan points.
ALMSDGRP	Alarm Signal Distributor Group. Records the circuit equipment, location, and type of circuit card containing signal distribution (SD) points.
ALMSD	Alarm Signal Distributor Point. Identifies the function to be performed by each of the assigned SD points in the alarm signal distributor groups.
ALMSC	Alarm Scan. Identifies the function to be performed by each of the assigned scan points in the alarm scan groups.
LNINV	Line Circuit Inventory. Lists the data for each line card slot.
LTDEF	Logical Terminal Definition. Defines ISDN terminals and AP for the type of service the terminal can access.
SPECCONN	Special Connections. Contains connections that cannot be modified with SERVORD.
KSETINV	Business Set Inventory. Identifies an LTID as an ISDN keyset and defines its attributes. The keyset can be a T2317 Business set, an M5317t Business Set and terminals, or equipment provided by other manufacturers.
KSETLINE	Keyset Line. Associates call appearances (ISDN LT call activators and indicators) to directory numbers and various feature options. This is an existing MDC table.
LTMAP	Logical Terminal Map. Maps ISDN LTs to a LEN or the TEI, depending on the AP (from table LTDEF).
KSETFEAT	Keyset Feature. Associates feature appearances (ISDN LT feature activators and indicators) with feature instances and various feature options.
MTAMDRVE	Metallic Test Access Minibar Driver. Concerns the Metallic Test Access. The Metallic Test Access (MTA) is a matrix of vertical and horizontal crosspoints, comparable to a minibar, that connect specified verticals to horizontal within the network. MTA is used to connect test equipment to a circuit that requires testing.

ISDN operations (continued)

Datafill tables required for ISDN operations on RSC-S (Sheet 4 of 4)

Table	Purpose of table
MTAVERT	Metallic Test Access Vertical. Identifies vertical connectivity to the MTA matrix.
MTAHORIZ	Metallic Test Access Horizontal. Lists the assignment of horizontal agents to a horizontal and horizontal group of MTAMs.

Note: Some data tables must be datafilled according to the kind of trunk group type required. Each trunk group type requires a specific form. Valid trunk group types are TI, TO, T2, IBNTI, IBNTO, IBNT2, PX, and ES.

Datafilling table DATASIZE

Table DATASIZE (Data Size) specifies the size of certain tables. For CSP02 and up, tuple SPECCONN is no longer required in table DATASIZE and a restart is no longer required to increase the table size. Prior to CSP02, to extend the length of table SPECCONN, increase the size in table DATASIZE and do a restart.

Datafilling table CLLI

Table CLLI (Common Language Location Identifier) uniquely identifies the far end of each announcement, tone, trunk group, test trunk, national milliwatt test lines, and service circuit. It lists the codes used to uniquely identify the far end of the following:

- announcement
- tone
- trunk group
- remote XPM
- packet handler (PH)
- scan points for the remote site

Some CLLI codes are contained in the EXT files and are added automatically to table CLLI when the feature is present in the switch. Other codes must be added to the CLLI table. The *Translations Guide* specifies whether these codes must be spelled exactly as specified or if the spelling can be original as long as the code is spelled the same for each table in which it appears.

This table is unchanged for the RSC-S with ISDN. Refer to the *Translations Guide* for a description of the fields and entry values.

ISDN operations (continued)

Datafilling table SITE

Table SITE contains the way an operating company can identify the office uniquely and all of the remote locations that home on to it.

The RSC-S with ISDN causes this table to be unchanged. Refer to the *Translations Guide* for a description of the fields and entry values.

Datafilling table PMLOADS

Table PMLOADS stores the device location of every PM loadfile which allows the XPM automatic loading feature to locate load files without user intervention.

Table PMLOADS lists active and a backup loadfiles. The active loadfile is always the default load used with the LOADPDM command and most system activities. The backup loadfile is used if there is a problem in loading or returning to service the active loadfile. The backup loadfile is always the unpatched loadfile Northern Telecom provides. Active and backup loadfiles are used when applying and removing patches.

Table PMLOADS stores data for the

- name of the active loadfile, which is the default load used with the LOADPDM command and most system initiated activities
- name of the backup loadfile, which is the load used if there is a problem in loading or returning to service the active loadfile. The backup loadfile is always the unpatched loadfile shipped with the SMS.
- file locations
- update active loadfile field, which indicates if the site wants the active fileid updated automatically. The feature allows the patched loadfile to be loaded into the XPM if a reload becomes necessary, which simplifies reload and recovery of the XPM. Active file information is updated through loadfile patching, if loadfile patching is enabled.

Active and backup files are used by the system as part of loading and recovery.

XPM load files must be datafilled in table PMLOADS before they can be datafilled in table LTCINV. Table LTCINV enforces this rule.

Note: An exception to this rule occurs during initial datafill, and during dump and restore. During these times, tuples in table PMLOADS are automatically datafilled when LTCINV tuples are datafilled.

ISDN operations (continued)

Prepatched XPM loads

Prepatched XPM loads background

Prepatched XPM loads (PPXLs) are XPM loadfiles with corrective patches built into the loadfile. PPXLs are incremental loads built using patch updates. Patch updates were originally used to create patch files which have been released to the field. Therefore, no functional or technical difference exists between an XPM load with patches and a PPXL with patches incorporated into the load. PPXLs are analogous to CM loads with patches built in based on date of shipment.

Implementation of PPXLs

A 1K data block containing patch IDs for patches included in the PPXL resides at at beginning of each PPXL loadfile. Although the patches are built into the PPXL, corresponding patch files for each patchid in the 1K data block must be present when the PPXL is datafilled in table PMLOADS.

When the PPXL is datafilled in table PMLOADS, the loadset is either modified if one already exists for the base load, or is initially created if the base load is new to the DMS-100 switch.

Note: Loadsets group all peripheral units loaded with the same load. To view all loadsets on the DMS-100 switch, access the PATCHER CI level and enter the command INFORM PMALL.

After the PPXL is added to table PMLOADS, it can be loaded either manually or automatically by the system recovery controller (SRC). After the PPXL is loaded, by either method, patching performed after loading the PPXL is either reduced or eliminated entirely, because most of or all the patches have already been included in the load.

Once the PPXL is loaded, additional patches can be applied to it or removed from it exactly in the way as a regular XPM load can. Also, patches built into the PPXL can be removed, as long as their corresponding patch files are present. Patches added or removed following loading of a PPXL are automatically applied or removed upon subsequent reloads of the PPXL.

PPXL Naming Convention

PPXL file names have *<date>* appended to the end of their corresponding base load name. For example, a PPXL load file created for base load ESA06AS would be named ESA06AS_951023. However, the base load name always remains the same. Base loads can be identified as any load not having the *<date>* suffix.

ISDN operations (continued)

The inherent value becomes the preservation of the patch stream with the ability to upissue a PPXL as required. A PPXL's vintage can always be identified using the date identifier.

PPXL storage requirements

When preparing to load PPXLs, Telcos are advised to double their XPM load storage requirements to accommodate the PPXLs. PPXLs require that the PPXL loadfile be stored on the ACTVOL device and the base load file be stored on the BKPVOL device.

Loading a PPXL

There are two methods of adding PPXLs to an office. The first is for upgrading an office to a new base load lineup, that is, when the base loadname is not currently in table PMLOADS. The second method is for adding PPXLs to offices that already have the base loadname in table PMLOADS. For example, CRI06AZ (the existing loadname) is appended to CRI06AZ_951023 (the PPXL added to the baseload).

Note 1: PPXLs are only supported on BCS36 or higher CM loads.

Note 2: PATCH JCK19 must be applied to the CM before continuing.

To load a PPXL in an office where the baseload is new to the office, use the following procedure.

Upgrading the base load

At the MAP

- 1 Copy the base loadfile and the PPXL loadfiles to disk volumes to be used for PM loads.

Note: Both the base load and the PPXL load should be copied to two disk volumes for redundancy.

- 2 Copy patches associated with the PPXL loads to the same disk volume used in step Section 1, "Copy the base loadfile and the PPXL loadfiles to disk volumes to be used for PM loads." on page -221. A list of patches associated with each PPXL load is included in the load tape shipment. After the PPXL file is present on disk, obtain a list of patches included in the PPXL by entering

```
>XPMLFP
```

```
>PATCHLIST FILE ppxl_filename
```

where

ppxl_filename

is the filename of the PPXL loaded added to the base load

- 3 Add a new tuple for the base load to table PMLOADS. Enter the base load for the LOADNAME, the base load name for the ACTFILE and the base load name again for the BKPFIL.

ISDN operations (continued)

- 4 Add the base loadname to the appropriate inventory table, for example LTCINV.
- 5 Edit the tuple added in step Section 3, "Add a new tuple for the base load to table PMLOADS. Enter the base load for the LOADNAME, the base load name for the ACTFILE and the base load name again for the BKPFIL." on page -221 to change the ACTFILE field from the base loadfile name to the PPXL filename. See the datafill example for table PMLOADS to see what this tuple looks like.
- 6 Set the loadset against both units of the XPM by entering

```
>PATCHER  
>SET loadname PM pm_type device_no unit_no
```

where
 - loadname**
is the name of the loadfile
 - pm_type**
is the type of PM requiring the loadset
 - device_no**
is the device number with a range of 0—255
 - unit_no**
is the unit number, 0 or 1
- 7 Load the PPXL into each unit of the XPM by entering

```
>BSY UNIT unit_no  
>LOADPM UNIT unit_no  
>RTS UNIT unit_no
```

where
 - unit_no**
is the unit number of the XPM to be loaded
- 8 Perform a SWACT of the XPM and repeat step Section 7, "Load the PPXL into each unit of the XPM by entering" on page -222.
 - Note 1:** Once loaded, the XPM can have additional patches applied or removed in the same manner used with XPM loads in the past. Also, any patches built into the PPXL can be removed from the load as long as the actual patch file is present on disk.
 - Note 2:** Patches added or removed following loading of a PPXL are automatically applied or removed upon subsequent reloads of the PPXL.
 - Note 3:** Non-PPXL patches are not removed when the PPXL is reloaded since there is no need to remove them because the removed patches are already out of the loadset.

To add PPXLs to an existing XPM load lineup, use the following procedure.

ISDN operations (continued)

Adding PPXLs to an existing PM load lineup
AT the MAP terminal

- 1 Verify all patch_ids associated with the PPXL are on the disk volume identified in table PMLOADS, field ACTVOL. If not present, copy the patches from tape to the correct volume. A list of patches in each PPXL is included with the PM tape shipment. Once the PPXLs are copied to disk, list the patches in the PPXL by entering

```
>XPMLFP
```

```
>PATCHLIST FILE ppxl_filename
```

where

ppxl_filename

is the filename of the PPXL loaded to disk

- 2 Copy the PPXL file (filename_date) to the disk volume used in step Section 1, "Verify all patch_ids associated with the PPXL are on the disk volume identified in table PMLOADS, field ACTVOL. If not present, copy the patches from tape to the correct volume. A list of patches in each PPXL is included with the PM tape shipment. Once the PPXLs are copied to disk, list the patches in the PPXL by entering" on page -223.
- 3 Copy the baseload to the disk volume identified in table PMLOADS, field BKPVOL.
- 4 Modify table PMLOADS as follows: If the XPM base loadname does not exist in table PMLOADS, add a new tuple using the previous "Upgrading baseload lineup" procedure. Otherwise, change field ACTFILE to the PPXL filename (filename_date). The loadset is either upgraded if one currently exists or created if one does not.
- 5 Set the loadset against both units of the XPM by entering

```
>PATCHER
```

```
>SET loadname PM pm_type device_no unit_no
```

where

loadname

is the name of the loadfile

pm_type

is the type of PM requiring the loadset

device_no

is the device number with a range of 0—255

unit_no

is the unit number, 0 or 1

- 6 Each unit of the XPM can be loaded with the PPXL by entering

```
>BSY UNIT unit_no
```

```
>LOADPM UNIT unit_no
```

```
>RTS UNIT unit_no
```

where

ISDN operations (continued)

unit_no
is the unit number of the XPM to be loaded

- 7 Perform a SWACT of the XPM and repeat step Section 6, "Each unit of the XPM can be loaded with the PPXL by entering" on page -223.

Note 1: Once loaded, the XPM can have additional patches applied or removed in the same manner used with XPM loads in the past. Patches built into the PPXL can be removed from the load if the actual patch file is on disk.

Note 2: Patches added or removed following loading of a PPXL are automatically applied or removed during subsequent reloads of the PPXL.

The following table shows the datafill specific to ISDN operations for table PMLOADS. Only those fields that apply directly to ISDN operations are shown.

Datafilling table PMLOADS for ISDN operations

Field	Subfield or refinement	Entry	Explanation and action
LOADNAME		alphanumeric (up to 8 characters)	Peripheral module load name. Enter the XPM load file name.
ACTFILE		alphanumeric (up to 32 characters)	Active load file name. The active XPM loadfile name (original or patched loadfile [PPXL]).
ACTVOL		alphanumeric (up to 16 characters)	Active volume. Identifies the device where the active loadfile is stored. Range: the set of disk drive unit (DDU) volumes and system load module (SLM) disks available to the CM (S00DXPM).
BKPFIL		alphanumeric (up to 32 characters)	Backup load file name. Identifies backup XPM loadfile name. It should be the same name as field LOADNAME.
BKPVOL		alphanumeric (up to 16 characters)	Backup volume. The device where the backup loadfile is stored. Range: the set of DDU volumes and SLM disks available to the CM (S00DXPM).
UPDACT		alphanumeric	Update active filename. Currently not used. Default value: N

Datafill example for table PMLOADS

The following example shows sample datafill for table PMLOADS.

ISDN operations (continued)**MAP display example for table PMLOADS**

LOADNAME	ACTVOL	UPDACT
ACTFILE	ACTVOL	
BKPFIL	BKPVOL	UPDACT

CRI06AZ		
CRI06AZ	S00DXPM	
CRI06AZ	S00DXPM	Y

Datafilling table LTCINV

Table Line Trunk Controller Inventory (LTCINV) identifies a host XPM-type peripheral to the DMS software. Information about the peripheral includes where it is located, the load required, and the network link connections. This table also supports the universal tone receiver (UTR) as an optional card.

The following peripheral types are defined in table LTCINV:

- LGC
- LTC
- line group controller with ISDN (LGCI)
- line trunk controller with ISDN (LTCI)
- digital trunk controller (DTC)
- digital trunk controller with ISDN (DTCI)

The following table shows the datafill specific to ISDN on RSC for table LTCINV. Only those fields that apply directly to ISDN on RSC are shown. Refer to the *Translations Guide* for a description of the fields.

ISDN operations (continued)

A field is added that contains the name of the loadfile that is associated with the electrically erasable programmable read-only memory (EEPROM).

Datafilling table LTCINV for ISDN on RSC-S (Sheet 1 of 3)

Field	Subfield or refinement	Entry	Explanation and action
LTCNAME		see subfields	Link trunk controller name. Subfields: XPMTYPE and XPMNO.
	XPMTYPE	LTC, LGC see explanation	XPM type. Enter LTC if trunking is to be supported. Enter LGC if lines only are to be supported. Entry values: LTC, DTC, LGC, SMR, SMS, SMU, IDTC, ILGC, ILTC, PDTC, BDTC, TRCC, PLGC, DTCI, TMS, SMA, and DFI. Note that LTC and LGC are used for both ISDN and non-ISDN XPMs.
	XPMNO	0 through 255	XPM number. Entry values: 0 through 127 for NT40, and 0 through 255 for SuperNode.
FRTYPE		LTE or LGE	Frame type. Enter LTE for the LTCl or LGE for the LGCl. When ISDN is supported, ensure that you datafill the OPTCARD with ISP.
Enter the location of the PM in fields FRNO, SHPOS, FLOOR, ROW, and FRPOS.			
EQPEC		code for the LTCl, 6X02AA or 6X02NA	Product equipment code. Enter the code for the LTCl, 6X02AA or 6X02NA.
LOAD		load listed in table PMLOADS	Load. Enter the load the PM is to use. It should be a load listed in table PMLOADS.
EXECTAB		see subfields	Executive table. Subfields: TRMTYPE, EXEC, and CONTMARK. The terminal type and its associated execs are datafilled together.
	TRMTYPE	POTS, KEYSET, RMM_TERM and ABTRK	Terminal type. Enter the type of terminal models to be used. POTS is for regular lines, KEYSET for EBS set and data lines, RMM_TERM for remotes, and ABTRK for IBN out trunks supporting BT3J type II / IV and DC5/ AC15 loop disconnect signaling.

ISDN operations (continued)

Datafilling table LTCINV for ISDN on RSC-S (Sheet 2 of 3)

Field	Subfield or refinement	Entry	Explanation and action
CSLNKTAB	EXEC	see explanation	Executive programs. Enter the exec program associated with the terminal type, such as POTSEX, KSETEX, RSMEEX, or DTCEX.
		see subfields	C-Side link table. Subfields: NMNO, NMPORT, and CONTMARK. Note: Changes to fields with multiple entries should be made in the PROMPT mode only.
	NMPAIR	0 through 31	Network module pair number. Enter the network link on which the PM is assigned, corresponding to PM C-side links 0 through 15. Enter 0 through 31.
OPTCARD	NMPORT	0 through 63	Network module port. Enter the network port corresponding to the above link.
		vector (10 entries maximum)	Optional card. A vector with up to ten entries. Enter when the LTC includes the UTR, TONE, and message card. If the CMR card is included, enter the CMRLOAD. Values: CMR5, UTR6, and UTR7, and ISP16. Note: Changes to fields with multiple entries should be made in the PROMPT mode only.
NT7X05AA		NT7X05AA	If NT7X05AA is entered, the system prompts for the slot_number. Slot numbers for the NT7X05AA in RCC2 are 5 and 23, or 7 and 21. Note 1: To support NT7X05 PRL functionality, MX77AA MX77AA is required in field PECS6X45. AX74AA AX74AA does not support NT7X05 PRL functionality. Note 2: If the CMR card is also provisioned, use slot numbers 7 and 21. (Slots 5 and 23 are dedicated to the CMR card.) If the CMR card is not provisioned, use either slots 5 and 23 or 7 and 21.
TONASET		tone set	Tone set. Contains the tone set for the switch being datafilled.

ISDN operations (continued)

Datafilling table LTCINV for ISDN on RSC-S (Sheet 3 of 3)

Field	Subfield or refinement	Entry	Explanation and action
PECS6X45		MX77AA MX77AA, or AX74AA AX74AA	6X45 equipment PECS. One PEC is required for each LTC unit. Enter the PEC for unit 0 first. The PEC must reflect minimum firmware capabilities in the processor complex of each unit. Note: When the NT7X05 PRL is datafilled as an optional card, enter MX77AA MX77AA. AX74AA AX74AA is not allowed as a valid value when the NT7X05 PRL is datafilled as an optional card because the NTAX74 CAP does not support NT7X05 PRL functionality.
E2LOAD		loadfile name	EEPROM file. Contains the name of the loadfile in the NTMX77AA EEPROM or the optional NTAX74AA EEPROM. Note: When the NT7X05 PRL is datafilled as an optional card, enter the loadfile name for the NTMX77 UP. The optional NTAX74AA CAP does not support NT7X05 PRL functionality.
OPTATTR		see subfield	Optional attribute. Since this is not a DTC for CCS7, leave blank. Subfield: CONTMARK.
PEC6X40		6X40AC	6X40 equipment PEC. Enter the version of the NT6X40 EQPEC card in the PM. NT6X40AC is the required version for ISDN.

Datafill example for table LTCINV

The following examples show sample datafills for table LTCINV for both an LTC provisioned with the NTMX77AA UP and an LTC provisioned with the optional NTAX74AA CAP, respectively.

ISDN operations (continued)**MAP display example for table LTCINV datafilled for NTMX77AA UP**

LTCNAME	FRTYPE	FRNO	SHPOS	FLOOR	ROW	FRPOS	EQPEC	LOAD
LTC 1	LTE	1	18	0	C	6	6X02AG	ELI08xx
EXECTAB								
(POTS POTSEX)(KEYSET KSETEX)(ABTRK DTCEX) (RMMTERM RSMEX) \$								
CSLNKTAB								
(0 5)(0 23)(1 5)(1 23)(0 30)(1 30)(0 38)(1 38)								
(0 43)(1 43)(0 47)(1 47)(0 54)(1 54)(0 62)(1 62) \$								
OPTCARD								
(UTR16)	(NT7X05AA	17)	(MSG6X69	(CMR18	CMRAG03)	(ISP16)	\$	
TOSET	PECS6X45		E2LOAD	OPATTR	PEC6X40			
NORTHAM	MX77AA	MX77AA	MX77xxxxx		\$	6X40AC		

Note 1: xx in field LOAD and xxxxx in field E2LOAD represent alphanumeric entries, for example B1 and XE01, respectively.

Note 2: If the shelf is equipped with a processor other than NTMX77 or the optional NTAX74, field E2LOAD is automatically datafilled with value NILLOAD.

Note 3: NTMX77 UP is required to support NT7X05 functionality. The optional NTAX74 CAP does not support NT7X05 PRL functionality. When a user attempts to datafill field PECS6X45 with AX74AA AX74AA instead of MX77AA MX77AA when NT7X05 is already datafilled as an optional card, the tuple change is disallowed and the MAP displays the following message:

Info: NT7X05AA requires MX77 processor

Note 4: When field PECS6X45 is datafilled with AX74AA AX74AA instead of MX77AA MX77AA, the load name prefix in field LOAD changes from ELI to XLI. For example, ELI08xx (for MX77) changes to XLI08XX (for AX74AA). The following example shows sample datafill for table LTCINV when the LTC is datafilled for the NTAX74AA CAP.

ISDN operations (continued)

MAP display example for table LTCINV datafilled for NTAX74AA CAP

LTCNAME	FRTYPE	FRNO	SHPOS	FLOOR	ROW	FRPOS	EQPEC	LOAD	
LTC 1	LTE	1	18	0	C	6	6X02UA	XLI08xx	
EXECTAB									
(POTS POTSEX) (KEYSET KSETEX) (ABTRK DTCEX) (RMMTERM RSMEX)								\$	
CSLNKTAB									
(0 5)(0 23)(1 5)(1 23)(0 30)(1 30)(0 38)(1 38)									
(0 43)(1 43)(0 47)(1 47)(0 54)(1 54)(0 62)(1 62)								\$	
OPTCARD									
(UTR9) (MSG6X69)			(CMR18 CMR03AG)			(ISP16)			\$
TOSET	PECS6X45	E2LOAD	OPATTR	PEC6X40					
NORTHAM	AX74AA AX74AA	AX74xxxx	\$	6X40AC					

Datafilling table CARRMTC

Table CARRMTC (Carrier Maintenance) contains the attributes of the DS-1 links. This table defines the line coding and frame formats for the DS-1 and provides maintenance control information for the links. This table is set up with default entries at loadbuild time.

Note: All BD connections to the PH must use the 6X50AB card and must be datafilled as 64k clear data with B8ZS zero logic.

Table CARRMTC allows the DMS switch administration to datafill maintenance control information on peripherals, out-of-service limits for alarms, and system RTS occurrences. For table CARRMTC, fields CSPMTYPE and SELECTOR (subfield of ATTR) have been expanded to include new PM type RCC2.

A carrier maintains communication on links connecting DMS peripherals to channel banks, DMS peripherals to remote DMS peripherals, or remote-to-remote DMS peripherals. Up to 16 entries exist for each type of peripheral that is capable of providing carrier links in the switch.

CPM carrier tuples contain various carrier maintenance limits and information for DS-1 carriers. It is recommended that, like XPM carriers, one tuple be added to provide the maintenance thresholds for CPM carriers. During initial program load (IPL), one default tuple is datafilled in table CARRMTC for each

ISDN operations (continued)

XPM type existing in the office and in field CSPMTYPE. Other tuples are added manually for different maintenance thresholds.

Before the XPM P-side inventory table tuple (in table RCCPSINV) is changed, a tuple in table CARRMTC must be datafilled. Before a tuple in table CARRMTC is deleted or changed, no links in table RCCPSINV can reference field TMPLNM in table CARRMTC.

The choice of entries for each carrier is datafilled in the inventory table of the C-side peripheral, table LTCPSINV. The following checks are made between table CARRMTC and table LTCPSINV:

- When a carrier index (CARRIDX) is datafilled in table LTCPSINV, an entry for the PM type (in this case RCC2 and LTC) must already be present in table CARRMTC.
- When an entry is deleted from table CARRMTC, the entry cannot be referenced by any carriers in table LTCPSINV; otherwise, the deletion command is rejected.
- When an existing entry in table CARRMTC is changed, table LTCPSINV is checked to determine if the entry is referenced by in-service carriers. If so, the change command is rejected and a list of the in-service carriers displays.

The following table shows the datafill specific to ISDN operations for table CARRMTC. Only those fields that apply directly to ISDN operations are shown. Refer to the *Translations Guide* for a description of the fields.

Datafilling table CARRMTC for ISDN on RSC-S

Field	Subfield or refinement	Entry	Explanation and action
	SELECTOR	carrier type	Selector. Enter carrier type. RCC2 has been added to the range of this subfield to allow carrier maintenance limits and alarms to be set for carriers having an RCC2 XPM on their C-side.
CARD		PEC of the DS-1 interface card	Card. Enter the PEC of the DS-1 interface card used. Entry value for the RCC2 is MX81AA (clear channel). Refinement attribute fields are the same for NTMX81AA as for NT6X50AB.

Datafill example for table CARRMTC

The following example shows sample datafill for table CARRMTC.

ISDN operations (continued)

MAP display example for table CARRMTC

Table: CARRMTC

CSPMTYPE	TMPLTNM	RTSML	RTSOL	ATTR										
RCC2	ESFB8ZF	255	255	DS1	NTMX81AA	MU_LAW	ESF	B8ZS						
CRC	NILDL	Y	100	300	50	50	150	1000	3	6	864	100	17	511
			255											

Datafilling table LTCPSINV

Table Line Trunk Controller P-side Link Inventory (LTCPSINV) contains host peripheral P-side link assignments. These links are DS30A, DS-1, or DCH. The key for this table is the same as for table LTCINV. Memory is automatically allocated for a maximum of 128 tuples. An entry is added automatically when a PM is datafilled in table LTCINV.

The carrier type is set in this table. The value entered after DS-1 is the value entered in table CARRMTC. The operating company can choose what value to use.

The following table shows the datafill specific to ISDN operations for table LTCPSINV. Only those fields that apply directly to ISDN operations are shown. Refer to the *Translations Guide* for a description of the other fields.

Datafilling table LTCPSINV for ISDN on RSC-S (Sheet 1 of 2)

Field	Subfield or refinement	Entry	Explanation and action
LTCNAME		see subfields	Link trunk controller name. Subfields: XPMTYPE and XPMNO.
	XPMTYPE	see explanation	PM type. This type must match the entry in table LTCINV. LTC and LGC are used for both ISDN and non-ISDN PMs.
	XPMNO	0 through 255	XPM number. Enter the XPM number.

Note: Datafill PSDATA fields according to the AREASELCT value. If AREASELCT is DS30A, DCH, or NILTYPE, no other fields require datafill. If PSDATA is DS-1, fill in fields CARRIDX and ACTION.

ISDN operations (continued)**Datafilling table LTCPSINV for ISDN on RSC-S (Sheet 2 of 2)**

Field	Subfield or refinement	Entry	Explanation and action
PSLNKTAB		see subfields	P-side link table. Subfields: PSLINK, PSDATA, and CONTMARK. Note: Changes to fields with multiple entries should be made in the PROMPT mode only.
	PSLINK	0 through 19	P-side link. Enter the P-side port number. The DCH must be datafilled in odd ports.
	PSDATA	see list	P-side data. Enter DS-1 for trunks and remote nodes, including RCC2 and RLCM. Enter DS30A for P-side interface to a local LCM. DCH is for interface to ISDN loops.

Note: Datafill PSDATA fields according to the AREASELCT value. If AREASELCT is DS30A, DCH, or NILTYPE, no other fields require datafill. If PSDATA is DS-1, fill in fields CARRIDX and ACTION.

Datafill example for table LTCPSINV

The following example shows sample datafill for table LTCPSINV.

MAP display example for table LTCPSINV

```

Table: LTCPSINV

LTCNAME                                PSLNKTAB
-----
LTC 1 (0 DS-1 ESFB8ZS N) (1 DS-1 ESFB8ZS N) (2 DS-1 ESFB8ZS N)
(3 DS-1 ESFB8ZS N) (4 DS-1 ESFB8ZS N) (5 DS-1 ESFB8ZS N)
(6 DS-1 ESFB8ZS N) (7 NILTYPE)(8 NILTYPE)
(9 NILTYPE ) (10 NILTYPE) (11 NILTYPE)
(12 NILTYPE) (13 NILTYPE) (14 NILTYPE)
(15 NILTYPE)(16 NILTYPE) (17 NILTYPE)
(18 NILTYPE) (19 NILTYPE)                                $

```

Datafilling table RCCINV

The Remote Cluster Controller Inventory (RCCINV) table contains the inventory data (except the P-side links) for the RCC2. A new optional card (ISP16) is allowed for the RCC2 in slot 4 of the RCC2 shelf

The following table shows the datafill specific to ISDN operations for table RCCINV. Only those fields that apply directly to ISDN operations are shown. Refer to *Translations Guide* for a description of the other fields.

ISDN operations (continued)

A field is added that contains the name of the loadfile that is associated with the EEPROM. Field FRTYPE contains new values.

Datfilling table RCCINV for ISDN on RSC-S (Sheet 1 of 5)

Field	Subfield or refinement	Entry	Explanation and action
RCCNAME		see subfields	RCC2 name. Subfields: SITE, PMTYPE, and RCCNO.
	SITE	alphanumeric	Site. Enter the site name assigned to the remote location. This entry should also appear in table SITE.
	PMTYPE	RCC2	PM type. Enter RCC2 for the ISDN RCC2.
	RCCNO	numeric	RCC2 Number. This number is unique by office and not by site.
FRTYPE		CRSC, CEXT	Frame type. Enter CRSC for the RCC2 shelf. Enter CEXT for the RCC2 extension shelf.
Enter the location of the RCC2 in fields FRNO, SHPOS, FLOOR, ROW, and FRPOS.			
EQPEC		MX85AA	Equipment PEC. The PEC for the RCC2 is MX85AA.
LOAD		alphanumeric	Load. Enter the load for the RCC2. Ensure that table PMLOADS contains this table.
EXECTAB		see subfields	Exec table. Subfields: TRMTYPE, EXEC, and CONTMARK. Note: Changes to fields with multiple entries should be made in the PROMPT mode only.
Note: When datfilling field C-side link table (CSLNKTAB), assure message links are not assigned to the same physical interface card. When the interface card supports two or more links, separate the message links by the number of links on the interface cards. This applies to all interface link types; DS-1, DS30, DS30A, or PCM-30. Table control will issue a warning if an attempt is made to assign message links on the same interface card. Assigning message links to the same interface card can cause an E1 outage (failure of all message links) if the card fails.			

ISDN operations (continued)**Datfilling table RCCINV for ISDN on RSC-S (Sheet 2 of 5)**

Field	Subfield or refinement	Entry	Explanation and action
	TRMTYPE	POTS, KEYSET, EBS, RMM_TERM, ABTRK, ESA, MX5X09, M5X12	Terminal type. Entry values: POTS (regular lines), KEYSET (electronic business set [EBS]/data lines), RMM_TERM (remote MTC trunks), ABTRK (regular trunks), ESA (ESA lines), or MX5X09 and M5X12 (Meridian 9- and 12-button sets, respectively).
	EXEC		Executive programs. Enter the execs associated with the terminal type, such as POTSEX, KSETEX, DTCEX, ESAEX, or RSMEX.
	CONTMARK	+ or \$	Continuation mark. Enter a plus sign (+) to continue, and a dollar sign (\$) to end the vector
CSPM		see subfields	C-side PM. Subfields: PMTYPE and XPMNO.
	PMTYPE	see list	PM type. Enter the type of peripheral to which the RCC2 is attached. Note that this LTC or LGC can be part of a host ISDN configuration.
	XPMNO	0 to 255	PM number. Enter the PM number to which the RCC2 C-side is attached.

Note: When datafilling field C-side link table (CSLNKTAB), assure message links are not assigned to the same physical interface card. When the interface card supports two or more links, separate the message links by the number of links on the interface cards. This applies to all interface link types; DS-1, DS30, DS30A, or PCM-30. Table control will issue a warning if an attempt is made to assign message links on the same interface card. Assigning message links to the same interface card can cause an E1 outage (failure of all message links) if the card fails.

ISDN operations (continued)**Datfilling table RCCINV for ISDN on RSC-S (Sheet 3 of 5)**

Field	Subfield or refinement	Entry	Explanation and action
CSLNKTAB		0 to 19	C-side link table. A vector with up to 16 entries. Enter LTC P-side DS-1 links (0-19) to which the RCC2 C-side is assigned. Note that all links for an RCC2 must terminate on the same LTC. Message links, first and third entries, must be assigned to different shelves, or units, of the frame so that link corruption or power failure does not affect service. Subfield: CONTMARK. Note: Changes to fields with multiple entries should be made in the PROMPT mode only.
	CONTMARK	+ or \$	Continuation mark. Enter a plus sign (+) to continue, and a dollar sign (\$) to end the vector.
ESA		Y or N	Emergency stand-alone. Controls whether the RCC2 has ESA capability.
INTRASW		Y or N	Intraswitching. Controls whether intraswitching is allowed.
OPTCARD		see list	Optional card. This is a vector with up to 10 entries. For the RCC2, slot 4 must be used for the ISP card. Datafill and deletion of LCME equipped with non-ISDN is permitted when the ISP is not defined. Slots 6 and 7 only can be used for the UTR card, and the CMR card can be plugged only into slot 5. Note that with the CMR card, only 10 DS-1s can be supported on the C-side and P-side. Examples are CMR5, ISP16, UTR6, and UTR7.
Note: When datafilling field C-side link table (CSLNKTAB), assure message links are not assigned to the same physical interface card. When the interface card supports two or more links, separate the message links by the number of links on the interface cards. This applies to all interface link types; DS-1, DS30, DS30A, or PCM-30. Table control will issue a warning if an attempt is made to assign message links on the same interface card. Assigning message links to the same interface card can cause an E1 outage (failure of all message links) if the card fails.			

ISDN operations (continued)

Datfilling table RCCINV for ISDN on RSC-S (Sheet 4 of 5)

Field	Subfield or refinement	Entry	Explanation and action
			<p>For an RCC2 with extended distance capability (EDC), the MSGMX76 card is required. Enter MSGMX76 REM HDLC to activate dynamic InSv upgrade from DMS-X to HDLC. Default: MSG6X69 REM DMSX. DMS-X to HDLC dynamic upgrade is not allowed in the inactive CM.</p> <p>Note: Changes to fields with multiple entries should be made in the PROMPT mode only.</p>
CMRLOAD		alphanumeric	Class modem resource load. Enter the CMR load name if the CMR card is datafilled in OPTCARD.
NT7X05AA		NT7X05AA	<p>If NT7X05AA is entered, the system prompts for the slot_number. Slot numbers for the NT7X05AA in RCC2 are 5 and 23, or 7 and 21.</p> <p>Note 1: To support NT7X05 PRL functionality, MX77AA MX77AA is required in field PECS6X45. AX74AA AX74AA in field PECS6X45 does not support NT7X05 PRL functionality.</p> <p>Note 2: If the CMR card is also provisioned, use slot numbers 7 and 21. (Slots 5 and 23 are dedicated to the CMR card.) If the CMR card is not provisioned, use either slots 5 and 23 or 7 and 21.</p>
<p>Note: When datafilling field C-side link table (CSLNKTAB), assure message links are not assigned to the same physical interface card. When the interface card supports two or more links, separate the message links by the number of links on the interface cards. This applies to all interface link types; DS-1, DS30, DS30A, or PCM-30. Table control will issue a warning if an attempt is made to assign message links on the same interface card. Assigning message links to the same interface card can cause an E1 outage (failure of all message links) if the card fails.</p>			

ISDN operations (continued)

Datfilling table RCCINV for ISDN on RSC-S (Sheet 5 of 5)

Field	Subfield or refinement	Entry	Explanation and action
PECS6X45		MX77AA MX77AA or AX74AA, AX74AA	<p>6X45 PEC. Enter the PEC of the NT6X45 card in RCC2 units 0 and 1. The PEC must reflect minimum firmware capabilities in the processor complex of each unit. For the RCC2, the entry value AX74AA has been added.</p> <p>Note: When the NT7X05 PRL is datafilled as an optional card, enter MX77AA MX77AA. AX74AA AX74AA is not allowed as a valid value when the NT7X05 PRL is datafilled as an optional card because the NTAX74 CAP does not support NT7X05 PRL functionality.</p>
E2LOAD		alphanumeric	EEPROM file. Contains the name of the loadfile that is loaded in the NTMX77AA EEPROM or the optional NTAX74AA EEPROM.

Note: When datafilling field C-side link table (CSLNKTAB), assure message links are not assigned to the same physical interface card. When the interface card supports two or more links, separate the message links by the number of links on the interface cards. This applies to all interface link types; DS-1, DS30, DS30A, or PCM-30. Table control will issue a warning if an attempt is made to assign message links on the same interface card. Assigning message links to the same interface card can cause an E1 outage (failure of all message links) if the card fails.

Datafill example for table RCCINV

The following examples show sample datafills for table RCCINV for both an RCC2 provisioned with the NTMX77AA UP and an RCC2 provisioned with the optional NTAX74AA CAP, respectively.

ISDN operations (continued)

MAP display example for table RCCINV

Table: RCCINV									
RCCNAME	FRTYPE	FRNO	SHPOS	FLOOR	ROW	FRPOS	EQPEC	LOAD	
CARY	RCC2	0							
	1101	CRSC	0	5	0	C	0	MX85AA	CRI08xx
EXECTAB								CONTMARK	
(POTS POTSEX) (KEYSET KSETEX) (RMM_TERM RSMEX) (ESALINES ESAEX) \$									
CSPM								CONTMARK	
LTC 1 (0) (1) (2) (3) (4) (5) (6) (7) \$									
ESA	INTRASW	OPTCARD		CMRLOAD				CONTMARK	
Y	Y	(UTR6)	(NT7X05AA 7)	(MSG6X69)	(CMR5	CMRAG03)	(ISP16)	\$	
TONESET	PECS6X45		E2LOAD		EXTINFO				
NORTHAM	MX77AA MX77AA		MX77xxxx		CEXT 0 4 0 E 15 MX86AA L				

Note 1: xx in field LOAD stands for alphanumeric text, for example B1.

Note 2: If the shelf is equipped with a processor other than NTMX77, field E2LOAD is automatically datafilled with the value of NILLOAD.

Note 3: NTMX77 UP is required to support NT7X05 functionality. The optional NTAX74 CAP does not support NT7X05 PRL functionality. When a user attempts to datafill field PECS6X45 with AX74AA AX74AA instead of MX77AA MX77AA when NT7X05 is already datafilled as an optional card, the tuple change is disallowed and the MAP displays the following message:

Info: NT7X05AA requires MX77 processor

Note 4: When field PECS6X45 is datafilled with AX74AA AX74AA instead of MX77AA MX77AA, the load name prefix in field LOAD changes from CRI to XRI. For example, CRI08xx (for MX77) changes to XRI08XX (for AX74AA). The following example shows sample datafill for table RCCINV when the RCC2 is datafilled for the NTAX74AA CAP.

ISDN operations (continued)

MAP display example for table RCCINV datafilled for NTAX74AA CAP

```

Table: RCCINV
RCCNAME      FRRTYPE FRNO SHPOS FLOOR ROW FRPOS  EQPEC  LOAD
-----
CARY RCC2 0
    1101 CRSC  0    5    0    C    0          MX85AA  XRI08xx
EXECTAB
-----
(POTS POTSEX) (KEYSET KSETEX) (RMM_TERM RSMEX) (ESALINES ESAEX) $
CSPM          CSLNKTAB
-----
LTC 1          (0) (1) (2) (3) (4) (5) (6) (7)          $
ESA  INTRASW  OPTCARD          CMRLOAD          CONTMARK
-----
Y    Y          (MSG6X69) (UTR6)(CMR5 CMRAG03) (ISP16)  $
TONESET  PECS6X45          E2LOAD          EXTINFO
-----
NORTHAM  AX74AA  AX74AA          AX74xxxxx  CEXT 0 4 0 E 15 MX86AA L
    
```

Error messages for table RCCINV

The following error messages apply to table RCCINV.

Error messages for table RCCINV on RSC-S (Sheet 1 of 2)

Error message	Explanation and action
Cannot datafill ISP16 optional card, ISDN subsystem is not present	The user attempted to datafill the ISP16 card without the ISDN subsystem in residence.
Cannot datafill ISP16 for Non CPM pm types	The user attempted to datafill the ISP16 card to a non-CPM PM type.
Failed to allocate pslinks table	No store is allocated for P-side tables.
Only one CMR card allowed	The user attempted to datafill more than one CMR card.
Info: NT7X05AA requires MX77 processor	A user has attempted to datafill field PECS6X45 with AX74AA AX74AA instead of MX77AA MX77AA when NT7X05 is already datfilled as an optional card.

ISDN operations (continued)**Error messages for table RCCINV on RSC-S (Sheet 2 of 2)**

Error message	Explanation and action
More than one OPTCARD specified for slot 6	The user attempted to datafill two optional cards on the physical slot 6 (UTR6 and CMR6).
More than one OPTCARD specified for slot 7	The user attempted to datafill two optional cards on the physical slot 7 (UTR7 and CMR7).
PECS6X45 must be MX77AA for CPM's—Only MX77 processor can be used by CPM—PECS6X45 MX77AA is valid for CPM'S only	The user attempted to datafill an MX77 PEC for a non-CPM shelf such as RCC.

Datafilling table RCCPSINV

The Remote Cluster Controller P-side Inventory (RCCPSINV) table contains only the P-side link assignments for the RCC2. Up to 54, 0-53, multiples of P-side link information may be datafilled for the RCC2.

Note: Physically, only 2 DS-1 C-side links are necessary, link 0 and link 2. The data control table for these links, table RCCPSINV, requires that link 1 be datafilled before link 2 can be datafilled. If only two links were required, which is not likely, link 1 would remain ManB. But it is necessary to datafill for 3 links in this table.

When an extension shelf is added, there are datafill restrictions for RCC2 P-side links connected to the extension shelf. The DS-1 and DCH links connected to the extension shelf can be datafilled only if an extension shelf was datafilled in table RCCINV. All the links connect to the extension shelf must be changed from DS-1/DCH to NILTYPE or DS30A in table RCCPSINV prior to deleting the extension shelf from table RCCINV.

Some of the DCH interface cards are placed in the same physical slots as the DS-1 interface cards so they cannot coexist. As a result, the following pairs of links cannot be both datafilled for the same extension shelf:

- DCH link 14 and any of the DS-1 links 24-31
- DCH link 15 and any of the DS-1 links 32-39
- DCH link 13 and any of the DS-1 links 40-47

Up to ten DCH cards can be datafilled in table RCCPSINV.

ISDN operations (continued)

The following table shows the datafill specific to ISDN operations for table RCCPSINV. Only those fields that apply directly to ISDN operations are shown. Refer to the *Translations Guide* for a description of the other fields.

Datafilling table RCCPSINV

Field	Subfield or refinement	Entry	Explanation and action
RCCNAME		see subfields	RCC2 name. Subfields: SITE, PMTYPE, and RCCNO.
	SITE	alphanumeric	Site. Enter the site name assigned to the remote location. It should also appear in table SITE.
	PMTYPE	RCC2	PM type.
	RCCNO	0 through 63	RCC2 number.
PSLNKTAB		see subfields	P-side link table. Subfields: PSLINK, PSDATA, and CONTMARK. Note: Changes to fields with multiple entries should be made in the PROMPT mode only.
	PSLINK	0 through 53	P-side link. Enter the P-side port number of the RCC2.
	PSDATA	DS-1 or NILTYPE	P-side data. Enter DS-1 for links to remote-off-remote, DS30A for links to RMMs or LCMs. Enter NILTYPE for unassigned links. When entering DCHs, ensure that they are on odd ports. If PSDATA is DS-1, fill in fields CARRIDX and ACTION.
CARRIDX		DEFAULT	Carrier index. Enter the name to index into table CARRMTC. Enter DEFAULT for the default template in table CARRMTC.
ACTION		Y or N	Action. Enter Y if the carrier should be removed from service when the out-of-service limit for frame, slip, errored-second, or severe errored-second is exceeded.
	CONTMARK	+ or \$	Continuation mark. Enter a plus sign (+) to continue, a dollar sign (\$) to end the vector.

Datafill example for table RCCPSINV

The following example shows sample datafill for table RCCPSINV.

ISDN operations (continued)**MAP display example for table RCCPSINV**

```

Table: RCCPSINV

RCCNAME                                                    PSLNKTAB
-----
CARY  RCC2 0 (0 DS-1 ESFB8ZS N) (1 DS-1 ESFB8ZS N)
(2 DS-1 ESFB8ZS N) (3 DS-1 ESFB8ZS N) (4 DS-1 ESFB8ZS N)
(5 DS-1 ESFB8ZS N) (6 DS-1 ESFB8ZS N) (7 DS-1 ESFB8ZS N)
(8 NILTYPE) (9 NILTYPE) (10 NILTYPE) (11 NILTYPE)
(12 NILTYPE) (13 NILTYPE) (14 NILTYPE) (15 NILTYPE)
(16 NILTYPE) (17 NILTYPE) (18 NILTYPE) (19 NILTYPE)
(20 NILTYPE) (21 NILTYPE) (22 NILTYPE) (23 NILTYPE)
(24 NILTYPE) (25 NILTYPE) (26 NILTYPE) (27 NILTYPE)
(28 NILTYPE) (29 NILTYPE) (30 NILTYPE) (31 NILTYPE)
(32 NILTYPE) (33 NILTYPE) (34 NILTYPE) (35 NILTYPE)
(36 NILTYPE) (37 NILTYPE) (38 NILTYPE) (39 NILTYPE)
(40 NILTYPE) (41 NILTYPE) (42 NILTYPE) (43 NILTYPE)
(44 NILTYPE) (45 NILTYPE) (46 NILTYPE) (47 NILTYPE)
(48 NILTYPE) (49 NILTYPE) (50 NILTYPE)
(51 NILTYPE) (52 NILTYPE) (53 NILTYPE)                                $

```

Error messages for table RCCPSINV

The following error messages apply to table RCCPSINV.

Error messages for table RCCPSINV (Sheet 1 of 2)

Error message	Explanation and action
Failed to allocate pslinks tables	Cannot allocate temporary store for P-side tables.
Cannot datafill &\$ in link &\$	P-side link restrictions for RCC2 prevent datafill (for example, if the first parameter is the link type that has been datafilled while the second parameter is the link number).
DS-1 not allowed on link &\$ when DCH datafilled on link &\$	P-side link restrictions for RCC2 prevent datafill.
Only 20 pside links are allowed	Operating company personnel attempted to datafill more than 20 P-side links on the RCC.
DS-1 not allowed in link # when there is no extension shelf.	Operating company personnel attempted to datafill a DS-1 link to the extension shelf when no extension shelf has been datafilled.

ISDN operations (continued)

Error messages for table RCCPSINV (Sheet 2 of 2)

Error message	Explanation and action
DCH not allowed in link # when there is no extension shelf.	Operating company personnel attempted to datafill a DCH link to the extension shelf when no extension shelf has been datafilled.
DS-1 not allowed in link # when DCH is in link #	Operating company personnel attempted to datafill a DS-1 link whose card position is in the same physical slot as the DCH card of the DCH already datafilled.

Datafilling table LCMINV

Table Line Controller Module Inventory (LCMINV) lists the LCM and expanded LCM (LCME) data assignment. LCMEs off the RCC2 are datafilled with the same values as LCMEs configured at the host site.

The following table shows the datafill specific to ISDN operations for table LCMINV. Only those fields that apply directly to ISDN operations are shown. Refer to the *Translations Guide* for a description of the other fields.

Datafilling table LCMINV for ISDN on RSC-S (Sheet 1 of 2)

Field	Subfield or refinement	Entry	Explanation and action
	PMTYTPE	LGC, LTC, ILGC, ILTC, PLGC, RCC, RCC2	Peripheral module type. Subfield: CSPMNO. Enter the type of PM to which the LCM is attached.
FRTYPE			Frame type. Enter the frame type in which the PM equipment is mounted. Enter CRSC for RCC2, and CEXT for the RCC2 extension shelf.
<p>Note 1: If BICTST is Y, field MEMSIZE must be 256K. If MEMSIZE is 64K, BICTST must be N.</p> <p>Note 2: Field LCMTYPE must be set to LCM or the tuple is rejected with the following message: BIC RELAY TEST ONLY PERFORMED ON XLCM.LCMTYPE FIELD MUST BE LCM ONLY.</p> <p>Note 3: If this field is changed while the BRT is running, this XLCM is included in the current test.</p> <p>Note 4: When datafilling fields link information (LNKINFO) or link map (LNKMAP), assure message links are not assigned to the same physical interface card. When the interface card supports two or more links, separate the message links by the number of links on the interface cards. This applies to all interface link types; DS-1, DS30, DS30A, or PCM-30. Table control will issue a warning if an attempt is made to assign message links on the same interface card. Assigning message links to the same interface card can cause an E1 outage (failure of all message links) if the card fails.</p>			

ISDN operations (continued)**Datafilling table LCMINV for ISDN on RSC-S (Sheet 2 of 2)**

Field	Subfield or refinement	Entry	Explanation and action
BICTST		Yes or No	BRT Test. Enter Y(es) or N(o). Yes includes the LCM in the next BRT schedule.
MEMSIZE		256K or 64K	Memory size. Enter the memory size of the LCM processor card. See Note 1.
<p>Note 1: If BICTST is Y, field MEMSIZE must be 256K. If MEMSIZE is 64K, BICTST must be N.</p> <p>Note 2: Field LCMTYPE must be set to LCM or the tuple is rejected with the following message: BIC RELAY TEST ONLY PERFORMED ON XLCM.LCMTYPE FIELD MUST BE LCM ONLY.</p> <p>Note 3: If this field is changed while the BRT is running, this XLCM is included in the current test.</p> <p>Note 4: When datafilling fields link information (LNKINFO) or link map (LNKMAP), assure message links are not assigned to the same physical interface card. When the interface card supports two or more links, separate the message links by the number of links on the interface cards. This applies to all interface link types; DS-1, DS30, DS30A, or PCM-30. Table control will issue a warning if an attempt is made to assign message links on the same interface card. Assigning message links to the same interface card can cause an E1 outage (failure of all message links) if the card fails.</p>			

Datafill example for table LCMINV

The following example shows sample datafill for table LCMINV.

ISDN operations (continued)**MAP display example for table LCMINV**

Table: LCMINV

LCMNM	FRTYPE	SHPOS	FLOOR	ROW	FRPOS	EQPEC	LOAD
HOST 02 0	LCEI	4	3	D	1	6X04AA	LCME06AW
CARY 05 0	CRSC	4	1	F	11	BX30AB	CRC36xx

CSPMNO	MEMSIZE	BICTST	LCMTYPE	RGEQUIP
LGC 0	256K	N	LCME	Y
RCC2 0	256K	N	LCME	Y

RNGTYPE	LCMSEL	LCMINFO	CONTMARK
C	HLCM	(12) (14) (13) (15)	\$
C	HLCM	(8) (10)	\$

Note: xx in field LOAD stands for two letters, for example BZ.

Datafilling table DCHINV

Table D-Channel Inventory (DCHINV) contains information about the DCH for peripherals that contain this card.. This data includes the DCH ID number (unique for each DCH), name and number of the host PM and the associated NT6X50 port, PEC (NTBX02AA, BA), load file, and port number. Up to ten DCHs can be defined for each CPM shelf.

The following table shows the datafill specific to ISDN operations for table DCHINV. Only those fields that apply directly to ISDN operations are shown. Refer to the *Translations Guide* for a description of the other fields.

Datafilling table DCHINV for ISDN on RSC

Field	Subfield or refinement	Entry	Explanation and action
PMTYPE		LGCI, LTCl, or RCC2	PM type. Enter the PM in which the DCH resides. Enter LGCI, LTCl, or RCC2.

ISDN operations (continued)**Datafill example for table DCHINV**

The following example shows sample datafill for table DCHINV.

MAP display example for table DCHINV

Table: DCHINV					
DCHNO	PMTYPE	PMNO	DCHPEC	LOAD	PORT
0	LTCI	0	BX02AA	ESH06AY	17
1	LTCI	0	BX02AA	ESH06AY	19
2	RCC2	0	BX02AA	ESH06AY	17
3	RCC2	0	BX02AA	ESH06AY	19

Datafilling table ISGDEF

Table ISDN Service Group Definition (ISGDEF) contains service and channels information for the PM supporting the DCH, as follows:

- ISDN service group (ISG) number
- name and number of the PM
- single or combined service attributes (BRI, packet data [PD])

When PD service is specified, the system automatically assigns the DCH channels. There are 29 BRI channels and 2 BD channels. More BD channels can be assigned if necessary (channel 0 is reserved for messaging).

When BRI service only is specified, all 31 channels are assigned as BRI. If an ISG is not defined for a DCH, that DCH is a spare (on hot standby). More than one spare can be provided.

To prevent the number of ISGs from exceeding the number of DCHs on the RCC2, DCHs cannot be datafilled before ISGs and DCHs cannot be removed from table DCHINV if they have an ISG assigned to them.

Channels specified as BD in table ISGDEF correspond with BD channels specified in table LTMAP, when SERVORD is used to map a packet LTID to a loop and Bd channel.

Table ISGDEF has been changed to allow the PM type RCC2 (the RCC2 PM type has the option of an ISP16 card).

ISDN operations (continued)

The following table shows the datafill specific to ISDN operations for table ISGDEF. Only those fields that apply directly to ISDN operations are shown. Refer to the *Translations Guide* for a description of the other fields.

Datafilling table ISGDEF for ISDN on RSC-S

Field	Subfield or refinement	Entry	Explanation and action
PMTYPE		LGCI, LTCI, or RCC2	PM type. Enter the PM supporting the DCH services.
SERVICE		BRA or PD	Service. Enter services provided by the ISG.
	CH_TYPE	NIL, RESERVED, BRA or BD	Channel type. Enter the type of service the D-channel will provide.
CHNLTAB		see subfields	<p>Channel information. This field is a vector with up to 32 entries specifying the functions of each channel. It is comprised of subfields DCHNL and CHNLTYPE. Use a dollar sign (\$) sign to terminate this field if fewer than 32 entries are made.</p> <p>Note: All BD channels must be assigned in descending order starting at 31, while BRA channels are assigned in ascending order starting at 0. Therefore, the order of datafill for BD and BRA channels is restricted as follows:</p> <p>For one night process (ONP), the warning message "BD channels must be higher than any BRA channels" is displayed to inform operating company personnel of the incorrect data ordering in the tuple transferred. However, the tuple is accepted by the table on the new side.</p> <p>For non-ONP, the error message "BD channels must be higher than any BRA channels" is displayed to inform operating company personnel of the incorrect data ordering in the tuple and the tuple is rejected.</p>

Datafill example for table ISGDEF

The following example shows sample datafill for table ISGDEF.

ISDN operations (continued)**MAP display example for table ISGDEF**

```

Table: ISGDEF
ISGNO   PMTYPE PMNO
                SERVICE
                CHNLTAB
-----
0  RCC2  0
                (BRA)   (PD)   $

(0 RESERVED)   (1 BRA) (2 BRA) (3 BRA)   (4 BRA) (5 BRA)
(6 BRA)   (7 BRA)   (8 BRA) (9 BRA)   (10 BRA) (11 BRA)
(12 BRA)  (13 BRA)  (14 BRA) (15 BRA) (16 BRA) (17 BRA)
(18 BRA)  (19 BRA)  (20 BRA) (21 BRA) (22 BRA) (23 BRA)
(24 BRA)  (25 BRA)  (26 BRA) (27 BRA) (28 BD) (29 BD)
(30 BD)   (31 BD)  $

1  RCC2  0
                (BRA)   (PD)   $

(0 RESERVED)   (1 BRA) (2 BRA) (3 BRA) (4 BRA) (5 BRA)
(6 BRA)   (7 BRA)   (8 BRA) (9 BRA)   (10 BRA) (11 BRA)
(12 BRA)  (13 BRA)  (14 BRA) (15 BRA) (16 BRA) (17 BRA)
(18 BRA)  (19 BRA)  (20 BRA) (21 BRA) (22 BRA) (23 BRA)
(24 BRA)  (25 BRA)  (26 BRA) (27 BRA) (28 BD) (29 BD)
(30 BD)   (31 BD)  $

2  LTC   0
                (BRA)   (PD)   $

(0 RESERVED)   (1 BRA) (2 BRA) (3 BRA) (4 BRA) (5 BRA)
(6 BRA)   (7 BRA)   (8 BRA) (9 BRA)   (10 BRA) (11 BRA)
(12 BRA)  (13 BRA)  (14 BRA) (15 BRA) (16 BRA) (17 BRA)
(18 BRA)  (19 BRA)  (20 BRA) (21 BRA) (22 BRA) (23 BRA)
(24 BRA)  (25 BRA)  (26 BRA) (27 BRA) (28 BD) (29 BD)
(30 BD)   (31 BD)  $

```

Datfilling table RMMINV

Table Remote Maintenance Module Inventory (RMMINV) identifies an RLCM, RSC-S, or OPM site with the frame type, frame number, floor, row, frame position, PEC, PM load and executive program loaded, and C-side PM attached to each RMM. Memory is dynamically allocated and the maximum size of this table is 255 entries.

ISDN operations (continued)

Field CSPMINFO of an RMM can be an RCC2 as well as the LTC or RCC. The C-side links of RMM must be defined to link 22 and 23 of the RCC2.

The following table shows the datafill specific to ISDN operations for table RMMINV. Only those fields that apply directly to ISDN operations are shown. Refer to the *Translations Guide* for a description of the other fields.

Datafilling table RMMINV for ISDN on RSC-S

Field	Subfield or refinement	Entry	Explanation and action
FRTYPE		CRSC, CEXT	Frame type. Enter CRSC for the RCC2 shelf. Enter CEXT for the RCC2 extension shelf.
CSPMINFO			C-side PM information. Subfields: RMMSELECTOR, CSIDEPM, and CSIDPORT.
	RMM SELECTOR		RMM selector. Enter the type of module where the RMM is located (RMMRCC or RMMRCC2).
	CSIDEPM		C-side peripheral module. Subfields: PMT and EXT_PMNO.
	PMT	RCC2	PM type. Based on the value in field RMMSELECTOR. Enter RCC2.
	EXTPMNO	0 through 127	External PM number. Enter the external PM number to which the RMM is attached. This number should also appear in table LCMINV or RCCINV.
If the field RMMSELECTOR is RMMRCC2, datafill subfield CSIDPORT as follows:			
	CSIDPORT	22 and 23	C-side port. Enter the C-side port connected to the RMM. Enter 22 and 23.

Datafill example for table RMMINV

The following example shows sample datafill for table RMMINV.

ISDN operations (continued)**MAP display example for table RMMINV**

Table: RMMINV							
RMMNAME	FRTYPE	FRNO	CRSC	SHPOS	FLOOR	ROW	FRPOS
CARY RMM	04	CRSC	0	51	0	C	5
CARY RMM	04	CRSC	0	51	0	D	5
EQPEC	LOAD	EXECS	CSPMINFO				
6X13AA	RMM05A	RSMEX	RMMRCC	RCC2	22		
6X13AA	RMM05A	RSMEX	RMMRCC	RCC2	23		

Error messages for table RMMINV

The following error message applies to table RMMINV.

Error messages for table RMMINV

Error message	Explanation and action
For RCC2 RMM allowed on p-side links 22 and 23	This message reaffirms that an RMM must be defined on links 22 and 23 of an RCC2.

Datafilling table LTGRP

Table LTGRP defines up to 32 logical terminal groups, including group ISDN. Group names contain up to eight alphanumeric characters. Each supports up to 1022 LTIDs. With 32 logical groups, up to 32 704 LTIDs(32 x 1022) can be defined. The key to this terminal is the logical terminal group. A logical terminal must be entered in table LTGRP before a logical terminal from this group can be datafilled in any other table. Note that ISDN is a permanent entry and cannot be added or deleted.

ISDN operations (continued)

The following table shows the datafill specific to ISDN operations for table LTGRP. Only those fields that apply directly to ISDN operations are shown. Refer to the *Translations Guide* for a description of the other fields.

Datafilling table LTGRP for ISDN on RSC-S

Field	Subfield or refinement	Entry	Explanation and action
GROUP			Logical group. Enter the name of the logical group of terminals.
GROUPNO		0 through 31 (non-SAPI), 0 through 15 (SAPI)	Group number. Enter the group number corresponding to a group name. The DPN recognizes LTs by LT group and LT number.
OPTIONS			Options. Enter SAPI16, the only option available. If specified, both packet and circuit switching terminals can be datafilled.

Note: DPN is a prefix for a series of packet data switches in the data networking system.

Datafill example for table LTGRP

The following example shows sample datafill for table LTGRP.

MAP display example for table LTGRP

Table: LTGRP			
GROUP	GROUPNO	OPTIONS	
ISDN	0	(SAPI16)	\$
LTCO	0	(SAPI16)	\$
RCC2 0	0	(SAPI16)	\$
TESTO	0	(SAPI16)	\$

Datafilling table LNINV

Table Line Circuit Inventory (LNINV) defines the site, line equipment number, and associated data for each line card circuit. With ISDN lines, the values for some fields are changed.

ISDN operations (continued)

The following table shows the datafill specific to ISDN operations for table LNINV. Only those fields that apply directly to ISDN operations are shown. Refer to the *Translations Guide* for a description of the other fields.

Datafilling table LNINV for ISDN on RSC-S

Field	Subfield or refinement	Entry	Explanation and action
LEN			Line equipment number. Subfields: SITE, FRAME, UNIT, LSG, and CIRCUIT.
	SITE		Site. Enter the site assigned to the remote location.
	FRAME	0 through 99	Frame. Enter the frame number.
	UNIT	0 or 1	Unit. Enter the unit number.
	LSG	0 through 15	Line subgroup. Enter LSG number.
	CIRCUIT	0 through 31	Circuit. Enter the line card circuit number.
CARDCODE			Cardcode. Enter BX27AA for LCME line cards.
PADGRP		NPDGRP	Pad group. Because no pad group can be assigned to ISDN lines, enter NPDGRP.
STATUS		HASU, WORKING, UNEQUIP, CUTOFF, or RESERVED	Status. Field RESERVED is controlled through SERVORD). Recommended entry: WORKING.
GND		N	Ground. For ISDN lines, enter N.
BNV		NL	Balanced network value. Because ISDN lines have a nonloaded network value, enter NL.
MNO		Y	Manual override. Because an on-hook balance network test does not update field BNV, enter Y.
CARDINFO		NIL	Card information. Because this field does not apply to ISDN lines, enter NIL.

Datafill example for table LNINV

The following example shows sample datafill for table LNINV.

ISDN operations (continued)

MAP display example for table LNINV


Table: LNINV

LEN	CARDCODE	PADGRP	STATUS	GND	BNV	MNO	CARDINFO
CARY 04 1 00 04	BX27AA	NPDGP	WORKING	N	NL	Y	NIL
CARY 04 1 00 05	BX27AA	NPDGP	WORKING	N	NL	Y	NIL
CARY 04 1 00 06	BX27AA	NPDGP	WORKING	N	NL	Y	NIL
CARY 04 1 00 07	BX27AA	NPDGP	WORKING	N	NL	Y	NIL

Datavfilling table LTDEF

Table Logical Terminal Definition (LTDEF) defines ISDN terminals and the AP for the type of service the the terminal can access. SERVORD is used to automatically datafill this table.

The following table shows the datafill specific to ISDN operations for table LTDEF. Only those fields that apply directly to ISDN operations are shown. Refer to the *Translations Guide* for a description of the other fields.



CAUTION
Use the Service Order system, not the table editor, to add and delete tuples to and from table LTDEF.
 Using the table editor to datafill this table can result in incompatible features being assigned to the line. The table datafill is shown here for information only.

Datavfilling table LTDEF for ISDN on RSC-S (Sheet 1 of 2)

Field	Subfield or refinement	Entry	Explanation and action
LTKEY			Logical terminal key. Subfields: LTGRP and LTNUM.
	LTGRP		Logical terminal group. Enter the LT group. The group ISDN is already defined.
	LTNUM	0 through 1022	Logical terminal number.

ISDN operations (continued)**Datafilling table LTDEF for ISDN on RSC-S (Sheet 2 of 2)**

Field	Subfield or refinement	Entry	Explanation and action
LTAP		B, D, BD, PB, 2B	Logical terminal access privilege. Enter one of the following access privileges: B for circuit-switching, D for D-channel packet-switching, BD for combined circuit-switching and D-channel packet-switching, PB for B-channel packet switching, or 2B for 2B circuit switching. Note: BD is for functional sets.
LTCLASS		BRAFS	Logical terminal class of service. Defines the set of services allowed for the LT. BRAFS is for a BRI functional set.

Datafill example for table LTDEF

The following example shows sample datafill for table LTDEF.

MAP display example for table LTDEF

```

Table: LTDEF

LTKEY  LTAP

-----
LTCLASS

LTCO      1  B
BRACS

LTCO      2  B
BRACS

.
.
.
RCC2 0 23  D
BRACS

RCC2 0 24  D
BRACS

```

ISDN operations (continued)

Datafilling table SPECCONN

Table Special Connections (SPECCONN) contains connections that cannot be modified using SERVORD. These connection types are as follows:

- Bd-channel
- Bb-channel
- B-channel to B-channel
- DS-1 to DS-1

The Bd-channel connection carries service access point identifier 16 (SAPI 16) packet data from a DCH to a PH. This connection supports up to 64 LTs.

The Bb-channel connection provides packet data service on a B-channel. The connection is between a B1 or B2 channel on a line card (at 64 kbit/s) and a DS-1 channel (64 kbit/s) to the PH.

The B-channel to B-channel connection is between a B1 or B2 channel on a line card to another B1 or B2 channel. The endpoints are on separate LCMEs with an AP of PB.

The DS-1 to DS-1 connection is between a DS-1 channel at a remote PH to a DS-1 channel at a local PH.

Note: The connection of four incoming 16 kbit/s D-channels are time-division-multiplexed to one 64 kbit/s DCH BRI channel is established automatically when an ISDN loop is provisioned as working in table LNINV. This connection is not provisioned in table SPECCONN.

Table SPECCONN routes DS-1 links to a packet handler. DS-1 links can be nailed-up through either the RCC2 or the LTCl. SPECCONN has been changed to accommodate an RCC2 entry in PMTYPE (subfield of SCSEL). The DS-1 endpoint of the RCC2 shelf can be defined in ports higher than 19.

ISDN operations (continued)

The following table shows the datafill specific to ISDN operations for table SPECCONN. Only those fields that apply directly to ISDN operations are shown. Refer to the *Translations Guide* for a description of the other fields.

Datafilling table SPECCONN for ISDN on RSC-S (Sheet 1 of 2)

Field	Subfield or refinement	Entry	Explanation and action
ENDPT1			End point 1. Identifies the first endpoint. Subfield: SCSEL and refinements.
	SCSEL	DS-1, ISLC, or DCHCHNL	End point selector. Enter the endpoint selector type.
			If SCSEL is datafilled DS-1, complete the following fields.
PM TYPE		LTC, LGC, or RCC2	Field long name. Enter the PM type.
PMNO		0 through 2047	Field long name. Enter the external number of the PM.
PMCKTNO		0 through 29	Field long name. This is the PM circuit number. Enter the P-side port of the PM.
PMCKTTS		1 through 31	Field long name. Enter the PM time slot (channel) on the DS-1.
			If SCSEL is datafilled ISLC, complete the following fields.
LEN			Line equipment number. Subfields: SITE, FRAME, UNIT, and DRAWER.
	SITE		Site name. Enter the site name assigned to the remote location. If the line is entered at the host, enter HOST.
	FRAME	0 through 99	Frame number. Enter the frame number.
	UNIT	0 or 1	Unit number. Enter the unit number.
	DRAWER	0 through 15	Line subgroup number. Enter the LCME line subgroup number.
CIRCUIT		0 through 31	Line card circuit number. Enter the LCME line card circuit number.
CHNL		D, B1, or B2	Channel. Enter the channel on the ISDN loop.

ISDN operations (continued)**Datafilling table SPECCONN for ISDN on RSC-S (Sheet 2 of 2)**

Field	Subfield or refinement	Entry	Explanation and action
If SCSEL is datafilled DCHCHNL, fill in the following fields.			
ISGNO		0 through 255	Integrated services group number. Enter the DCH number, as identified in table DCHINV.
CHNL		0 through 31	Channel number. Enter the channel number on the DCH.
CONTYPE		PEND, CON, or CAB (see explanation)	Connection type. Enter PEND (pending), CON (connected), or CAB (connected with A- and B-bit signaling).
STATUS		PMBUSY, ACTIVE, INACTIVE, MTC, or NOINTEG	Connection status. Values: PMBUSY (peripheral is busy), ACTIVE (physical connection established, integrity found and being checked constantly), INACTIVE (connection not set up), MTC (connection is broken and is used by maintenance), or NOINTEG (physical connection established, but integrity either not found or is lost. Both XPMs are in service).

Datafill example for table SPECCONN

The following example shows sample datafill for table SPECCONN. The order of endpoints does not affect this table.

ISDN operations (continued)**MAP display example for table SPECCONN**

Table: SPECCONN

ENDPT1		ENDPT2		CONTYPE	STATUS
DS-1	RCC2 0 5 1	DCHCHNL 0	28	CON	ACTIVE
DS-1	RCC2 0 5 2	DCHCHNL 0	29	CON	ACTIVE
DS-1	RCC2 0 5 3	DCHCHNL 0	30	CON	ACTIVE
DS-1	RCC2 0 5 4	DCHCHNL 0	31	CON	ACTIVE
DS-1	RCC2 0 5 5	DCHCHNL 1	28	CON	ACTIVE
DS-1	RCC2 0 5 6	DCHCHNL 1	29	CON	ACTIVE
DS-1	RCC2 0 5 7	DCHCHNL 1	30	CON	ACTIVE
DS-1	RCC2 0 5 8	DCHCHNL 1	31	CON	ACTIVE
DS-1	LTC 0 9 1	DCHCHNL 2	28	CON	ACTIVE
DS-1	LTC 0 9 2	DCHCHNL 2	29	CON	ACTIVE
DS-1	LTC 0 9 3	DCHCHNL 2	30	CON	ACTIVE
DS-1	LTC 0 9 4	DCHCHNL 2	31	CON	ACTIVE
DS-1	LTC 0 9 5	DCHCHNL 2	28	CON	ACTIVE
DS-1	LTC 0 9 6	DCHCHNL 2	29	CON	ACTIVE
DS-1	LTC 0 9 7	DCHCHNL 2	30	CON	ACTIVE
DS-1	LTC 0 9 8	DCHCHNL 2	31	CON	ACTIVE

Datafilling table KSETINV

Table Business Set Inventory (KSETINV) identifies an LTID as an ISDN keyset and defines its attributes. The keyset can be a T2317 business set, an M5317T business set and terminals, or equipment provided by other manufacturers.

The following table shows the datafill specific to ISDN operations for table KSETINV. Only those fields that apply directly to ISDN operations are shown. Refer to the *Translations Guide* for a description of the other fields.

**CAUTION**

Use the Service Order system, not the table editor, to add and delete tuples to and from table KSETINV

Using the table editor to datafill this table can result in incompatible features being assigned to the line. The table datafill is shown here for information only.

ISDN operations (continued)

Datafilling table KSETINV

Field	Subfield or refinement	Entry	Explanation and action
KSETLEN			Keyset line equipment number (LEN). Subfield: LTID.
	LTID		Logical terminal identifier. Subfields: LTGRP and LTNUM.
	If subfield LTID is datafilled, subfields LTGRP and LTNUM require datafill.		
	LTGRP		Logical terminal group. Enter the LT group name. This group name can contain a maximum of 8 characters.
SETDATA	LTNUM	1 through 1022	Logical terminal number. Enter the LT number in the group.
	KSET	ISDNKSET	Keyset. Contains the key-set type for ISDN terminals. ISDNKSET is the only response. KSET refinements include FANUM.
	FANUM	2 through 64	FAP programmable. Enter the FAP programmable on the LT.

Datafill example for table KSETINV

The following example shows sample datafill for table KSETINV.

MAP display example for table KSETINV

Table: KSETINV			
KSETLEN	SETDATA	OPTIONS	CONTRMARK
RCC2 0	ISDNSET	64	\$
RCC2 1	ISDNSET	64	\$
RCC2 2	ISDNSET	64	\$
RCC2 3	ISDNSET	64	\$
RCC2 4	ISDNSET	64	\$

ISDN operations (continued)**Datafilling table KSETLINE**

Table Keyset Line (KSETLINE) associates CAPs (ISDN LT call activators and indicators) with DNs and various feature options. This is an existing MDC table.

The following table shows the datafill specific to ISDN operations for table KSETLINE. Only those fields that apply directly to ISDN operations are shown. Refer to the *Translations Guide* for a description of the other fields.

**CAUTION**

Use the Service Order system, not the table editor, to add and delete tuples to and from table KSETLINE.

Using the table editor to datafill this table can result in incompatible features being assigned to the line. The table datafill is shown here for information only.

Datafilling table KSETLINE

Field	Subfield or refinement	Entry	Explanation and action
KSETKEY			Keyset key. This field is the key to table KSETLINE and contains subfields LTID and KEY.
	LTID		Logical terminal identifier. Subfields: LTGRP and LTNUM.
			If subfield LTID is datafilled, subfields LTGRP and LTNUM require datafill.
	LTGRP		Logical terminal group. Enter the LT group name. This group can contain a maximum of 8 characters or digits.
	LTNUM	1 through 1022	Logical terminal number. Enter the LT number in the group.
	KEY	see explanation and action	Key. Enter the number associated with the the physical set key to which the DN is assigned. Key number 1 must be programmed for the set's primary DN and must be datafilled before any of the set's other DNs. For M5317 sets, only keys 1 through 11 can be used for DNs (CAPs) and keys 1 through 33 for FAPs.

ISDN operations (continued)

Datafill example for table KSETLINE

The following example shows sample datafill for table KSETLINE.

MAP display example for table KSETLINE

Table: KSETLINE										
KSETKEY	KEY	FORMAT	DNRESULT				CONTMARK			
RCC2	0	1	DN	Y	2265235	BNRMC	0	0	613	+
					DCPX	SMDR				\$

Datafilling table LTMAP

Table Logical Terminal Map (LTMAP) maps ISDN LTs to a LEN or the TEI, depending on the AP (from table LTDEF). SERVORD is used to datafill this table automatically.

The following table shows the datafill specific to ISDN operations for table LTMAP. Only those fields that apply directly to ISDN operations are shown. Refer to the *Translations Guide* for a description of the other fields.

Datafilling table LTMAP for ISDN on RSC-S (Sheet 1 of 2)

Field	Subfield or refinement	Entry	Explanation and action
LTKEY			Logical terminal key. Subfields: LTGRP and LTNUM.
	LTGRP		Logical terminal group. Enter the LTGRP.
	LTNUM	0 through 1022	Logical terminal number.
OPTION		TEI, PHI, BCH, DCHCHNL	Option. The option based on the terminal AP selected. The option determines the fields that appear next. Use TEI for B- and BD-type terminals, PHI for D- and BD- type terminals and BCH for high-speed packet data (PB) type terminals.
	TEI	see explanation	Terminal endpoint identifier. Enter the TEI for B and BD type terminals (range: 0 through 127). Use 1 and 2 for M5317 devices, and 21 through 26 for D-channel devices.

ISDN operations (continued)**Datafilling table LTMAP for ISDN on RSC-S (Sheet 2 of 2)**

Field	Subfield or refinement	Entry	Explanation and action
	PHI	0 through 1023	Packet handler interface.
	BCH	B1 or B2	B-channel. Enter the dedicated B-channel for high-speed packet data.
	DCHCHNL	0 through 31	DCH channel. Enter the specific channel located on a particular DCH card. The option is valid for BD- and D-type terminals.

Datafill example for table LTMAP

The following example shows sample datafill for table LTMAP.

MAP display example for table LTMAP

Table: LTMAP											
LTKEY			MAPPING					OPTION			
RCC2	0	1	LEN	CARY	04	1	00	01	(TEI	1)\$
RCC2	0	2	LEN	CARY	04	1	00	01	(TEI	2)\$
RCC2	0	3	LEN	CARY	04	1	00	05	(TEI	1)\$
RCC2	0	4	LEN	CARY	04	1	00	05	(TEI	2)\$
RCC2	0	5	LEN	CARY	04	1	12	00	(TEI	1)\$
RCC2	0	6	LEN	CARY	04	1	12	00	(TEI	2)\$
RCC2	0	200	LEN	CARY	04	1	00	01	(TEI 21)	(DCHCHNL 28)\$
RCC2	0	201	LEN	CARY	04	1	00	05	(TEI 21)	(DCHCHNL 29)\$
RCC2	0	202	LEN	CARY	04	1	00	01	(TEI 22)	(DCHCHNL 30)\$
RCC2	0	203	LEN	CARY	04	1	00	01	(TEI 23)	(DCHCHNL 29)\$
RCC2	0	204	LEN	CARY	04	1	12	06	(TEI 21)	(DCHCHNL 30)\$
RCC2	0	205	LEN	CARY	04	1	12	00	(TEI 21)	(DCHCHNL 29)\$

Datafilling table KSETFEAT

Table Keyset Feature (KSETFEAT) associates FAPs (ISDN LT feature activators and indicators) with feature instances and various feature options. The datafill for this table follows existing MDC translations.

ISDN operations (continued)

The following table shows the datafill specific to ISDN operations for table KSETFEAT. Only those fields that apply directly to ISDN operations are shown. Refer to the *Translations Guide* for a description of the other fields.



CAUTION

Use the Service Order system, not the table editor, to add and delete tuples to and from table KSETFEAT.

Using the table editor to datafill this table can result in incompatible features being assigned to the line. The table datafill is shown here for information only.

Datafill example for table KSETFEAT

The following example shows sample datafill for table KSETFEAT.

MAP display example for table KSETFEAT

Table: KSETFEAT

FEATKEY	FEATURE				KVAR	
RCC2	0	1	SDY	SDY	Y	Y

Datafilling trunk, alarm, and line testing tables

The following tables are used to define special trunks (such as those that would be used when running a test CLLI), test points for lines (such as the 3X09 card in the RMM), or the alarm scan points.

The following table are used to define special trunk, alarm, and line testing tables.

- TRKSGRP
- TRKMEM
- ALMSCGRP
- ALMSDGRP
- ALMSD
- ALMSC
- MTAMDRVE
- MTAVERT

ISDN operations (continued)

These tables require no new datafill for the RSC-S product. For complete information about all tables in this list, refer to the *Translations Guide*.

Translations verification tools

Translations verification (TRAVER) is used to verify the routing of a call through datafill. Following is the syntax for TRAVER. The use of TRAVER for packet-switched calls is not supported.

```
>TRAVER orig digits trace authcode mfst billno bill_mfst
```

SERVORD

SERVORD allows operating company personnel to add or delete line-associated data without having to access tables, which saves time and minimizes errors.

When datafilling lines for an LCME off of an RCC2, the datafill sequence is unchanged. The following examples contain both prompt and non-prompt modes to show which fields are datafilled. This section provides example datafill sessions. For complete information on SERVORD commands, ISDN prompt definitions and line service options, and query commands, refer to the *SERVORD Reference Manual*.

SERVORD limitations and restrictions

ISDN operations has no SERVORD limitations and restrictions.

SERVORD prompts**Setting up a logical terminal (using >SLT)**

The SLT command controls data associated with an ISDN LT for both circuit switching and packet switching. Use the SLT command to define a new LT, delete an LT, detach an LT from a LEN, and attach an LT to a LEN with the associated option.

Providing B-channel switched service

To define a new circuit-switch LT, operating company personnel must first create an LTID and then associate it with a LEN and a TEI. The following tables show examples of the SERVORD entry process.

ISDN operations (continued)

SERVORD example: creating an LTID in prompt mode

```
SO:
> SLT
SONUMBER : NOW 90 03 14 AM
>
LTID:
> ISDN 1
FUNCTION:
> ADD
CS:
> Y
PS:
> N
```

SERVORD example: creating an LTID in non-prompt mode

```
SONUMBER : NOW 90 03 14 AM
>SLT $ ISDN 1 ADD Y N
```

SERVORD example: attaching a LEN and TEI in prompt mode

```
SO:
>SLT
SONUMBER : NOW 90 03 14 AM
>
LTID:
>ISDN 1
FUNCTION:
>ATT
LEN
>2 0 6 0
OPTION:
>TEI
TEI:
>1
>$
```

SERVORD example: attaching a LEN and TEI in non-prompt mode

```
SONUMBER : NOW 90 03 14 AM
>SLT $ ISDN 1 ATT 2 0 6 0 TEI 1 $
```


ISDN operations (continued)

SERVORD example: defining the CAP/DN on the M5317T key in prompt mode

```

SO:
>NEW
SONUMBER : NOW 90 03 14 AM
> $
DN:
>8344040
LCC:
>ISDNKSET
GROUP
>ISDNGRP
SUBGRP:
>0
NCOS:
>0
SNPA:
>919
KEY:
>1
MAXKEYS:
>33
RELKEY:
>24
LATTANAME:
>NILLATA
LTG:
> 0
LEN:
>ISDN 1
OPTKEY:
>25
OPTION:
>HLD
OPTKEY:
>$

```

SERVORD example: defining the CAP/DN on the M5317T key in non-prompt mode

```

SONUMBER : NOW 90 03 14 AM
>NEW $ 8344040 ISDNKSET ISDNGRP 0 0 919 1 33 24 NILLATA 0 ISDN 1 25 HLD$

```

ISDN operations (continued)

Deleting the LTID

In order to delete the ISDN terminal appearance, perform the following:

- delete the CAP/DN on the M5317T key
- disassociate the LEN
- detach the LTID
- remove the LTID

SERVORD example: disassociating the CAP/DN in prompt mode

```
SO:
>OUT
SONUMBER : NOW 90 03 14 AM
>
DN:
> 8344040
LEN:
>ISDN 1
INTERCEPT_NAME:
>BLDN
```

SERVORD example: disassociating the CAP/DN in non-prompt mode

```
SONUMBER : NOW 90 03 14 AM
>OUT $ 8344040 ISDN 1 BLDN
```

SERVORD example for detaching the LTID in prompt mode

```
SO:
>SLT
SONUMBER : NOW 90 03 14 AM
>
LTID:
> ISDN 1
FUNCTION:
>DET
```

SERVORD example for detaching the LTID in non-prompt mode

```
SONUMBER : NOW 90 03 14 AM
>SLT $ ISDN 1 DET
```

ISDN operations (continued)

SERVORD example: removing the LTID in prompt mode

```
SO:
>SLT
SONUMBER   : NOW 90 03 14 AM
>
LTID:
>ISDN 1
FUNCTION:
>REM
```

SERVORD example: removing the LTID in non-prompt mode

```
SONUMBER   : NOW 90 03 14 AM
>SLT $ ISDN 1 REM
```

Providing access privilege D

The first command is used to attach a low-speed D-channel packet-switching LT with an LTID of ISDN 32, that is associated with LEN RLGH 04 1 0 2. The following commands attach, detach, and remove the LT.

```
>SLT $ ISDN 32 ADD N D
>SLT $ ISDN 32 ATT RLGH 4 1 0 2 TEI 21 DCHCHNL 1 $
>SLT $ ISDN 32 DET
>SLT $ ISDN 32 REM
```

Providing Bb-channel service

The first command is used to attach a high-speed B-channel packet-switching LT with an LTID of ISDN 32, that is associated with LEN RLGH 04 1 0 2 and a TEI of 21. The subsequent commands are used to attach, detach, and remove the LT.

ISDN operations (end)

```
>SLT $ ISDN 32 ADD N D
>SLT $ ISDN 32 ATT RLGH 4 1 0 2 BCH B1 $
>SLT $ ISDN 32 DET
>SLT $ ISDN 32 REM
```

Downloading firmware

Functional group

BAS00003

Feature package

NTXR42AA Firmware Downloading

Release applicability

BCS34 and higher

Prerequisites

Downloading firmware requires the following feature packages:

- NTX000AA Bilge
- NTX001AA Common Basic
- NTX270AA New Peripheral Maintenance
- NTR34AA XPM-PLUS Basic

Description

Feature AF3658 develops a process to load firmware to the EEPROM of the Unified Processor (UP) (NTMX77AA) card. This card is on the main shelf of the Remote Switching Center-SONET (RSC-S) configuration.

Firmware changes include:

- the upgrade of programs to comply with improvements
- the maintenance of multiple versions of EPROMs

Operating company personnel currently do not have to prepare, send and change the EPROMs on all cards to update firmware. Operating company personnel do not have to return all EEPROMs on current UP cards that have a previous firmware version.

Operation

The UP is equipped with flash memory chips. To upgrade the chips the system loads an image. This method is the same as the method the system uses to load software from a host switch. The NTMX77AA card contains two flash EEPROMS or banks. These banks are 256-kbyte programmable chips. One bank is in the executable mode. The other bank is in the loadable mode. The *executable* EEPROM runs random access memory (RAM). The *loadable* EEPROM is for backup. If the executable EEPROM is defective, the loadable EEPROM takes over and becomes the executable EEPROM.

Downloading firmware (continued)

To download, the user enters the current LOADPM command from the maintenance and administration position (MAP) when a new firmware load is available.

In-service firmware downloading

In-service firmware downloading permits XPM firmware loading in an XPM unit while the unit is in service (InSv). This feature reduces the amount of time one unit of the XPM is out-of-service (OOS). In-service firmware downloading supports NTMX77 and NTAX74 processors.

Note: In-service firmware downloading refers to the loading of the firmware while the unit is InSv. The upgrade of the firmware occurs with the XPM unit out of service (OOS).

This feature introduces the LOADFW command. The LOADFW command distinguishes the firmware load application from the firmware upgrade application. The command syntax for the LOADFW command is:

```
LOADFW: Load Firmware onto a PM or unit.
        All parameter will execute LOADFW on
        all PMs in the post set of the same
        PM type displayed on the MAP.
        LOADFW UPGRADE must be used to
        activate the new firmware.
Parms: <DEVICE> {UNIT <UNIT_NO> {0 TO 1},
                PM,
                INACTIVE,
                ACTIVE}
        [<FILENAME> STRING]
        [UPGRADE]
        [NOWAIT]
        [ALL]
```

To download firmware to the XPM, execute one of the following commands. The following are examples of the LOADFW command.

```
>LOADFW PM
```

or

```
>LOADFW UNIT unit_no
```

or

```
>LOADFW INACTIVE
```

Downloading firmware (continued)

Note 1: If the `firmware_file` is not specified with the `LOADFW` command, the command applies the `firmware_file` datafiled in the appropriate inventory table.

Note 2: By using the `LOADFW` command without the `UPGRADE` option, the firmware downloads to the DMS system.

XPM Firmware Loader Robustness CM Component disables the firmware option of the `LOADPM` command. A message is output to the user if the firmware option of the `LOADPM` command is used. This message states this option is not supported and to use the `LOADFW` command.

Loadfile verification

Integrity checks are performed on the firmware for loadfile accuracy. A loadfile record length check ensures the file is a firmware file before submission to the XPM. If the record length is not 54, a message is output to the user and the `LOADFW` command fails.

Another accuracy check is a 32-bit cyclic redundancy check (CRC) along with a 16-bit checksum. The CM sends a validation message to the XPM to verify the accuracy of the firmware load. The XPM extracts the CRC and checksum that is in the firmware load. The XPM computes the CRC value and the checksum. The XPM compares the computed and extracted values to see if the values are the same. The XPM sends the result of the comparison to the CM.

To verify the firmware load enter the following command at the MAP display terminal:

```
>QUERYPM CNTRS
```

Firmware upgrade

After loadfile verification, the XPM can be upgraded to the new firmware. To upgrade the firmware use one of the following command string sets:

```
>BSY PM
```

```
>LOADFW PM UPGRADE
```

```
>RTS PM
```

or

```
>BSY UNIT unit_no
```

```
>LOADFW UNIT unit_no UPGRADE
```

```
>RTS UNIT unit_no
```

Downloading firmware (continued)

or

>BSY INACTIVE

>LOADFW INACTIVE UPGRADE

>RTS INACTIVE

Note: By using the LOADFW command with the UPGRADE option, the firmware is upgraded to the new firmware load.

When this procedure is performed on a by-unit basis, perform a switch of activity (SwAct) followed by the RTS command. Execute the LOADFW command with the UPGRADE option on the now inactive unit.

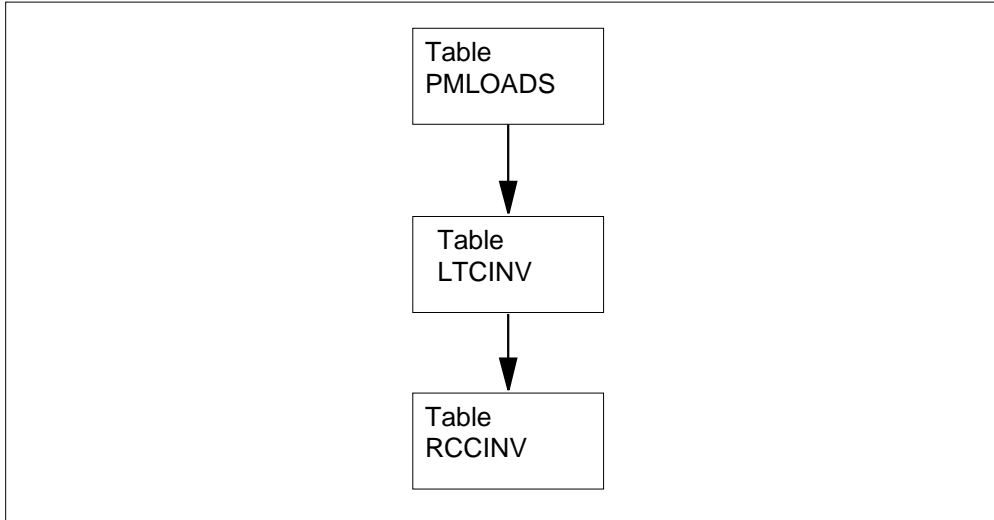
Translations table flow

The following list describes downloading firmware translations tables:

- Table PMLOADS stores the device location of each peripheral module (PM) load file. The table PMLOADS stores the device to map between the load names and devices the loads reside on. The PM load files must be entered in table PMLOADS before the files can be used in the inventory tables. Load information in field LOADNAME and associated data is entered in field LOAD for tables LTCINV, LCMINV and RMMINV.
- Table LTCINV contains the inventory data for PM types. This table does not contain the peripheral side (P-side) link assignment. This table defines the line trunk controller (LTC) or line group controller (LGC) on the central side (C-side) of the RCC2. Load information for this table is entered in field LOAD and corresponds to the LOADNAME tuple from table PMLOADS.
- Table RCCINV maintains a list of RCC2s. This list is entered in the Digital Multiplex System (DMS). Table RCCINV contains inventory data (except P-side link assignments) for the RCC2. This table does not contain P-side link assignments. The table information identifies the location of the RCC2, the load and exec lineups required and the network link connections. The C-side digital signal 1 (DS-1) assignments for the RCC2 are entered in table RCCINV. In addition, intraswitching is entered in table RCCINV.

The following flowchart describes downloading firmware translations.

Downloading firmware (continued)

Table flow for downloading firmware**Limits**

The following limits apply to downloading firmware:

- The unit must be at task level. The system loads the software load to the unit. The unit is ManB.
- The unit must be equipped with the NTMX77AA 0D2 card and must support current messaging. The version of the EPROM must be equal to or higher than AB02.

Interactions

Downloading firmware does not have functionality interactions.

Activation/deactivation by the end user

Downloading firmware does not require activation or deactivation by the end user.

Billing

Downloading firmware does not affect billing.

Station Message Detail Recording

Downloading firmware does not affect Station Message Detail Recording.

Office parameters

Downloading firmware does not affect office parameters.

Downloading firmware (continued)

Datavill sequence

The following table lists the tables that require datavill to implement downloading firmware. The tables appear in the order in which the tables are to be entered.

Datavill tables required for Firmware downloading

Table	Purpose of table
PMLOADS	Table Peripheral Module Loads. Stores the device location of each peripheral module (PM) load file to map between the load names and devices on which the loads reside. This storage permits autoloading to locate load files without the intervention of personnel. The expanded peripheral module (XPM) load files must be entered in table PMLOADS. The files must be entered before the files can be used in the XPM inventory tables.
LTCINV	Table Line Trunk Controller Inventory. Contains the PM inventory data. This table does not contain the P-side link assignments. This table defines the line trunk controller (LTC)/line group controller (LGC) on the C-side of the RCC2.
RCCINV	The Remote Cluster Controller Inventory. Contains inventory data for the RCC2. Does not contain P-side link assignments. RCC2 C-side DS-1 assignments for are entered in table RCCINV.

Datavilling table PMLOADS

Table PMLOADS stores the device location of every PM loadfile. The XPM automatic loading can locate load files without user intervention.

Table PMLOADS contains active and a backup loadfiles. The active loadfile is always the default load used with the LOADPDM command and most system activities. Use the backup loadfile if you cannot load or return to service the active loadfile. The backup loadfile is always the unpatched loadfile Northern Telecom provides. Active and backup loadfiles are used to apply and remove patches.

Table PMLOADS stores data for

- the name of the active loadfile. The active loadfile is the default load used with the LOADPDM command and most activities that the system initiates.
- the name of the backup loadfile. The backup loadfile is the load used if an attempt to load or return the active loadfile to service fails. The backup loadfile is always the unpatched loadfile provided with the SMS.
- the file locations
- the update active loadfile field. The field indicates if the site requires the active file ID to be updated automatically. The feature allows the system

Downloading firmware (continued)

to load the patched loadfile to the XPM if a reload is necessary. This event simplifies the reload and the recovery of the XPM. Loadfile patching updates active file information if loadfile patching is enabled.

The system uses active and backup files as part of loading and recovery. The system must enter XPM load files in table PMLOADS before the system can enter the files in table LTCINV. Table LTCINV enforces this rule.

Note: An exception to this rule occurs during the initial entry and during dump and restore. The system enters tuples in table PMLOADS when the system enters LTCINV tuples.

Prepatched XPM loads

Prepatched XPM loads background

Prepatched XPM loads (PPXL) are XPM loadfiles that have correcting patches built into the loadfile. The PPXLs are increased loads built with patch updates. Patch updates originally created patch files released to the field. Operating or technical differences do not occur between an XPM load with patches and a PPXL with patches in the load. The PPXLs are like the CM loads with patches built in based on date of shipment.

Implementation of PPXLs

A 1-kbyte data block contains the patch IDs for the patches included in the PPXL. The data block is at the start of each PPXL loadfile. The patches are in the PPXL. The associated patch files for each patch ID are in the 1-kbyte data block. The patch files must be present when the system enters the PPXL in table PMLOADS.

When the system enters the PPXL in table PMLOADS, the loadset can change if the loadset is present for the base load. The loadset can be created at the start if the base load is new to the DMS-100 switch.

Note: Loadsets group all peripheral units loaded with the same load. To view all loadsets on the DMS-100 switch, access the PATCHER CI level and enter the command INFORM PMALL.

The system adds the PPXL to table PMLOADS. The user or the system can use the system recovery controller (SRC) to load the PPXL. Patching that occurs after the PPXL load is complete is either reduced or eliminated.

When the system or user loads the PPXL, additional patches can be applied to or removed from the PPXL. A PPXL load is the same as a normal XPM load. Patches built in the PPXL can be removed. The patch files associated with the patches are present.

Downloading firmware (continued)

After a PPXL load, the system applies or removes added or removed patches after additional reloads of the PPXL.

PPXL Naming Convention

The PPXL file names have *<date>* appended to the end of the associated base load name. For example, a PPXL load file created for base load ESA06AS is named ESA06AS_951023. The base load name, does not change. Base loads are any loads that do not have the *<date>* suffix. The inherent value becomes the preservation of the patch stream with the ability to up-issue a PPXL. Use the date identifier to identify a PPXL vintage.

PPXL storage requirements

When the operating company prepares to load the PPXLs, the operating companies must double XPM load storage requirements to accommodate the PPXLs. The PPXLs require the storage of the PPXL loadfile on the ACTVOL device. The PPXLs require the storage of the base load file on the BKPVOL device.

Loading a PPXL

The following two methods are available to add the PPXLs to an office:

- upgrade an office to a new base load lineup when the base loadname is not in table PMLOADS.
- add the PPXLs to offices that have the base loadname in table PMLOADS

The current loadname, ESA06AS, appends to ESA06AS_951023. The PPXL added to the baseload is ESA06AS_951023.

Note 1: The PPLs are only supported on BCS36 or higher CM loads.

Note 2: Apply the PATCH JCK19 to the CM before you continue.

To load a PPXL in an office in which the baseload is new to the office, use the following procedure.

Upgrading the base load

At the MAP terminal

- 1 Copy the base and the PPXL loadfiles to disk volumes used for PM loads.
Note: Copy both the base and the PPXL loads to two disk volumes for redundancy.
- 2 Copy patches for the PPXL loads to the same disk volume used in step 1. A list of patches for each PPXL load is in the load tape shipment. To obtain a list of patches after the PPXL file is present on disk, type
>XPMLFP

Downloading firmware (continued)

>PATCHLIST FILE ppxl_filename

where

ppxl_filename

is the filename of the PPXL loaded added to the base load

- 3 Add a new tuple for the base load to table PMLOADS. Enter the base load for the LOADNAME. Enter the base load name for the ACTFILE. Enter the base load name again for the BKPFIL.
- 4 Add the base loadname to the correct inventory table. An example of a correct table is the LTCINV.
- 5 Edit the tuple added in step Section 3, "Add a new tuple for the base load to table PMLOADS. Enter the base load for the LOADNAME. Enter the base load name for the ACTFILE. Enter the base load name again for the BKPFIL." on page -279 to change field ACTFILE from the base loadfile name to the PPXL filename. Refer to the datafill example for table PMLOADS to see how this tuple looks.
- 6 To set the loadset against both units of the XPM, enter

>PATCHER

>SET loadname PM pm_type device_no unit_no

where

loadname

is the name of the loadfile

pm_type

is the type of PM requiring the loadset

device_no

is the device number with a range of 0-255

unit_no

is the unit number, 0 or 1

- 7 To load the PPXL in each unit of the XPM, enter

>BSY UNIT unit_no

>LOADPM UNIT unit_no

>RTS UNIT unit_no

where

unit_no

is the unit number of the XPM to load

- 8 Perform a SWACT of the XPM and repeat step Section 7, "To load the PPXL in each unit of the XPM, enter" on page -279.

Note 1: When loaded, the XPM can have additional patches applied or removed in the same method used with XPM loads in the past. Any patches built in the PPXL are removable from the load as long as the patch file is present on disk.

Note 2: After a PPXL load, the system applies or removes added or removed patches after additional reloads of the PPXL.

Note 3: The system does not remove non-PPXL patches when the user or system reloads the PPXL. The removed patches are out of the loadset.

Downloading firmware (continued)

To add PPXLs to a current XPM load lineup, perform the following procedure:

Adding PPXLs to a current PM load lineup

At the MAP terminal

- 1 Verify that all patch_ids associated with the PPXL are on the disk volume identified in table PMLOADS, field ACTVOL. If the patches are not present, copy the patches from tape to the correct volume. The PM tape shipment includes a list of patches in each PPXL. To list the patches in the PPXL when the PPXL are copied to disk, enter

```
>XPMLFP
```

```
>PATCHLIST FILE ppxl_filename
```

where

ppxl_filename

is the filename of the PPXL loaded to disk

- 2 Copy the PPXL file (filename_date) to the disk volume used in step Section 1, "Verify that all patch_ids associated with the PPXL are on the disk volume identified in table PMLOADS, field ACTVOL. If the patches are not present, copy the patches from tape to the correct volume. The PM tape shipment includes a list of patches in each PPXL. To list the patches in the PPXL when the PPXL are copied to disk, enter" on page -280.
- 3 Copy the baseload to the disk volume identified in table PMLOADS, field BKPVOL.
- 4 If the XPM base loadname is not present in table PMLOADS, add a new tuple. Use the previous upgrading baseload lineup procedure to add a new tuple. Under any other conditions, change field ACTFILE to the PPXL filename (filename_date). The system upgrades the loadset if a loadset is available. The system creates a loadset if a loadset is not available.
- 5 To set the loadset against both units of the XPM, enter

```
>PATCHER
```

```
>SET loadname PM pm_type device_no unit_no
```

where

loadname

is the name of the loadfile

pm_type

is the type of PM that requires the loadset

device_no

is the device number with a range of 0-255

unit_no

is the unit number, 0 or 1

- 6 To load each unit of the XPM with the PPXL, enter

```
>BSY UNIT unit_no
```

```
>LOADPM UNIT unit_no
```

```
>RTS UNIT unit_no
```

Downloading firmware (continued)

where

unit_no

is the unit number of the XPM to load

- 7 Perform a SWACT of the XPM and repeat step Section 6, "To load each unit of the XPM with the PPXL, enter" on page -280.

Note 1: When loaded, the XPM can have additional patches applied or removed. The application or removal of the patches is the same as for XPM loads in the past. Patches built in the PPXL can be removed from the load if the correct patch file is on disk.

Note 2: After a PPXL load, the system applies or removes added or removed patches after additional reloads of the PPXL.

The following table describes the specified entries for Downloading firmware for table PMLOADS. Only the fields that apply directly to Downloading firmware appear.

Datafilling table PMLOADS

Field	Subfield or refinement	Entry	Explanation and action
LOADNAME		alphanumeric (up to 8 characters)	Peripheral module load name. Enter the XPM load file name.
ACTFILE		alphanumeric (up to 32 characters)	Active load file name. The active XPM loadfile name original or patched loadfile (PPXL).
ACTVOL		alphanumeric (up to 16 characters)	Active volume. Identifies the device that contains the active loadfile. Range: the set of disk drive unit (DDU) volumes and system load module (SLM) disks available to the CM (S00DXPM).
BKPFIL		alphanumeric (up to 32 characters)	Backup load file name. Identifies backup XPM loadfile name. The loadfile name must be the same name as field LOADNAME.
BKPVOL		alphanumeric (up to 16 characters)	Backup volume. The device that stores the backup loadfile. Range: the set of DDU volumes and SLM disks available to the CM (S00DXPM).
UPDACT		alphanumeric	Update active filename. Not currently used. Default value: N.

Datafill example for table PMLOADS

The following example shows sample datafill for table PMLOADS.

Downloading firmware (continued)

MAP display example for table PMLOADS

LOADNAME	ACTVOL	BKPVOL	UPDACT

ESA06AS			
ESA06AS	S00DXPM		
ESA06AS	S00DXPM		Y

Datafilling table LTCINV

The following table describes the datafill for downloading firmware for table LTCINV. Only the fields that apply directly to downloading firmware appear. Refer to the *Translations Guide* for a description of the other fields.

Datafilling table LTCINV

Field	Subfield or refinement	Entry	Explanation and action
LOAD		alphanumeric	Load. Enter the RCC2 load. The load must display a load that appear in table PMLOADS.
PROCPEC		MX77AA, MX77AA or AX74AA AX74AA	Processor equipment product engineering codes. Each LTC unit requires the PEC. Enter the PEC for unit 0 first. The PEC must reflect minimum firmware capabilities in the processor complex of each unit.
E2LOAD		alphanumeric	EEPROM file. Contains the name of the loadfile loaded in the NTMX77AA EEPROM or the optional NTAX74AA EEPROM. Note: When the NT7X05 PRL appears as an optional card, enter the loadfile name for the NTMX77 UP. The optional NTAX74AA CAP does not support NT7X05 PRL use.
Note 1: Make changes to fields with multiple entries only in the PROMPT mode. In nonprompt mode it you can exclude current entries.			
Note 2: Enter the continuation mark (+) in fields with multiple possible entries when the next line specifies additional data. Make this entry when additional records are entered. Enter the end mark (\$) in fields with multiple possible entries after the last entry.			

Downloading firmware (continued)**Datafill example for table LTCINV**

The following examples show sample entries for table LTCINV. One example is an LTC that has the NTMX77AA UP. The other example is an LTC that has the optional NTAX74AA CAP.

MAP display example for table LTCINV

LTCNAME	FRTYPE	FRNO	SHPOS	FLOOR	ROW	FRPOS
LTC 1	LTE	2	2	2	A	2
EQPEC	[LOAD]	EXECTAB				
6X02xx	[ELI08xx]	(POTS POTSEX) (KEYSET KSETEX)				\$
CSLNKTAB						
(1 48) (13 61) (5 14) (2 31) (4 29)						\$
OPTCARD						
(UTR15) (ISP16) (NT7X05AA 7) (MSG6X69) (CMR18 CMRAG03)\$						
TONESET	[PROCPEC]	[E2LOAD]	OPATTR	PEC6X40		
NORTHAM	[MX77AA]	[MX77AA]	[MX77xxxx]	\$	6X40AA	

Note 1: xx in field LOAD and xxxx in field E2LOAD represent alphanumeric entries. Examples of the entries are B1 and XE01. Each example appears in the sequence provided.

Note 2: If the shelf is equipped with a processor other than NTMX77 or the optional NTAX74, the system enters field E2LOAD with value NILLOAD.

Note 3: When field PROCPEC is entered with AX74AA AX74AA instead of MX77AA MX77AA, the load name prefix in field LOAD changes from ELI to XLI. For example, ELI08xx (for MX77) changes to XLI08XX (for AX74AA). The following example shows sample datafill for table LTCINV when the RCO2 is entered for the NTAX74AA CAP.

Downloading firmware (continued)

MAP display example for table LTCINV datafiled for NTMX77AA UP

Table: LTCINV

LTCNAME	FRTYPE	FRNO	SHPOS	FLOOR	ROW	FRPOS	EQPEC	LOAD
LTC 1	LTE	1	18	0	C	6	6X02AG	XLI08xx
EXECTAB								CONTMARK
(POTS POTSEX)(KEYSET KSETEX)(RMM_TERM RSMEX)(ABTRK DTCEX) \$								
CSLNKTAB								CONTMARK
(9 17)(13 61)(5 14)(0 29)(1 30)(2 31)(3 28)(4 29) \$								
OPTCARD						CMRLOAD	CONTMARK	
(UTR6)(TONE6X79)(MSG6X69) (CMR18 CMRAG03) \$								
TONESSET	PROCEPC		E2LOAD		OPATTR	PEC6X40		
NORTHAM	AX74AA	AX74AA	AX74xxxx		\$	6X40AC		

Datafilling table RCCINV

Table Remote Cluster Controller Inventory (RCCINV) contains inventory data for the RCC2. This table does not contain P-side link assignments. The C-side DS-1 assignments for the RCC2 appear in table RCCINV.

Downloading firmware (continued)

The following table describes the datafill for Downloading firmware for table RCCINV. Only the fields that apply directly to downloading firmware appear. Refer to the *Translations Guide* for a description of the other fields.

Datafilling table RCCINV

Field	Subfield or refinement	Entry	Explanation and action
LOAD		alphanumeric	Load. Enter the load the RCC2 must use. The RCC2 must display a load listed in table PMLOADS.
PROCPEC		MX77AA, MX77AA or AX74AA, AX74AA	Processor equipment product engineering codes. Enter the PEC of the NTMX77 card in RCC2 units 0 and 1. The PEC must reflect the minimum firmware functionalities in the processor complex of each unit. For the RCC2, entry value AX74AA is added.
E2LOAD		alphanumeric	EEPROM file. Contains the name of the loadfile loaded in the NTMX77AA EEPROM or in the optional NTAX74AA EEPROM.
<p>Note 1: Make changes to fields with multiple entries only in the PROMPT mode. In nonprompt mode you can exclude current entries.</p> <p>Note 2: Enter the continuation mark (+) in fields with multiple possible entries when the next line specifies additional data. Enter the (+) mark if additional records are entered. Enter the end mark (\$) in fields with multiple possible entries after the last entry.</p> <p>Note 3: When you enter field C-side link table (CSLNKTAB), make sure message links are not assigned to the same physical interface card. When the interface card supports two or more links, separate the message links by the number of links on the interface cards. This method of separation applies to all interface link types. These types are DS-1, DS30, DS30A or PCM-30. Table control generates a warning if an attempt occurs to assign message links on the same interface card. The assignment of message links to the same interface card can cause an E1 outage. An E1 outage is a failure of all message links. This outage occurs when the card fails.</p>			

Datafill example for table RCCINV

The following examples show sample entries for table RCCINV. The table contains an RCC2 supplied with the NTMX77AA UP. The table contains an RCC2 supplied with the optional NTAX74AA CAP. Each entry appears in the sequence provided.

Downloading firmware (continued)

MAP display example for table RCCINV entered for NTMX77AA UP

Table: RCCINV

RCCNAME	FRTYPE	FRNO	SHPOS	FLOOR	ROW	FRPOS	EQPEC	LOAD		
CARY	RCC2	0	CRSC	0	5	0	C	0	MX85AA	CRI08xx
EXECTAB									CONTMARK	
(POTS POTSEX) (KEYSET KSETEX) (ABTRK DTCEX) (RMM_TERM RSMEX)									+	
(ESALINES ESAEX)									\$	
CSPM	CSLNKTAB								CONTMARK	
LTC	1	(0)	(1)	(2)	(3)	(4)	(5)	(6)	(7)	\$
ESA	INTRASW	OPTCARD				CMRLOAD			CONTMARK	
Y	Y	(UTR6)	(MSG6X69)	(NT7X05AA	7)	(CMR18	CMRAG03)	(ISP16)	\$	
TONESSET	PROCPEC		E2LOAD		EXTINFO					
NORTHAM	MX77AA	MX77AA	MX77xxxx		CEXT 0 4 0 E 15 MX86AA L					

Note 1: xx in field LOAD and xxxx in field E2LOAD represent alphanumeric entries. Examples of the entries are B1 and XE01 in the sequence provided.

Note 2: If the shelf is equipped with a processor other than NTMX77 or the optional NTAX74, the system enters field E2LOAD with value NILLOAD.

Note 3: When the system enters field PROCPEC with AX74AA AX74AA instead of MX77AA MX77AA, the load name prefix in field LOAD changes. The load name prefix changes from CRI to XRI. For example, CRI08xx (for MX77) changes to XRI08XX (for AX74AA). The following example shows sample datafill for table RCCINV when the system enters the RCC2 for the NTAX74AA CAP.

Downloading firmware (end)**MAP display example for table RCCINV entered for NTAX74AA CAP**

Table: RCCINV										
RCCNAME	FRTYPE	FRNO	SHPOS	FLOOR	ROW	FRPOS	EQPEC	LOAD		
MELB	RCC2	0	CRSC	0	5	0	C	0	MX85AA	XRI08xx

EXECTAB	CONTMARK									

(POTS POTSEX) (KEYSET KSETEX) (ABTRK DTCEX) (RMM_TERM RSMEX) +										
(ESALINES ESAEX) \$										
CSPM	CSLNKTAB CONTMARK									

LTC	1	(0)	(1)	(2)	(3)	(4)	(5)	(6)	(7)	\$
ESA	INTRASW	OPTCARD		CMRLOAD				CONTMARK		

Y	Y	(UTR6)	(MSG6X69)	(CMR18		CMRAG03)	(ISP16)		\$	
TONESSET	PROCPEC		E2LOAD		EXTINFO					

NORTHAM	AX74AA		AX74AA		AX74xxxx		CEXT 0 4 0 E 15 MX86AA L			

Translation verification tools

Downloading firmware does not use translation verification tools.

SERVORD

Downloading firmware does not use SERVORD.

Subscriber Module SLC-96/Remote

Functional group

BAS00016

Feature package

NTXA85AB Subscriber Module SLC-96/Remote

Release applicability

BCS34 and up

Prerequisites

Subscriber Module SLC-96/Remote requires the following feature packages:

- NTX000AA Bilge
- NTX001AA Common Basic
- NTX145AA Remote Switching Center
- NTX270AA New Peripheral Maintenance Package
- NTX398AA SCM-100S
- NTX901AA Local Features I

Description

Feature AF3721 permits the Subscriber Module SLC-96/Remote (SMS-R) to be configured as a peripheral-side (P-side) node off an RCC2. The changes needed to support the SMS-R in the Remote Switching Center-SONET (RSC-S) are:

- In a dual configuration, interlinks reside on the P-side of the RCC2.
- P-side links of an RCC2 contain 54 ports. The software must be able to support SMS-R central-side (C-side) link numbers greater than 20.

Note: The SMS-R is also called the Subscriber Carrier Module-100S Remote.

Operation

The SMS-R homes off the RSC-S to provide remote-off-remote direct digital interface for TR-008 digital loop carriers. An SMS-R is required to operate in a RSC-S adjacent to the RCC2. The design of the SMS-R is based on the design of the Subscriber Carrier Module 100S (SMS). The SMS is an XMS-based peripheral module (XPM) which enables end-to-end digital connection of the Remote Concentrator SLC-96 (RCS) to the DMS-100 network.

Subscriber Module SLC-96/Remote (continued)

Translations table flow

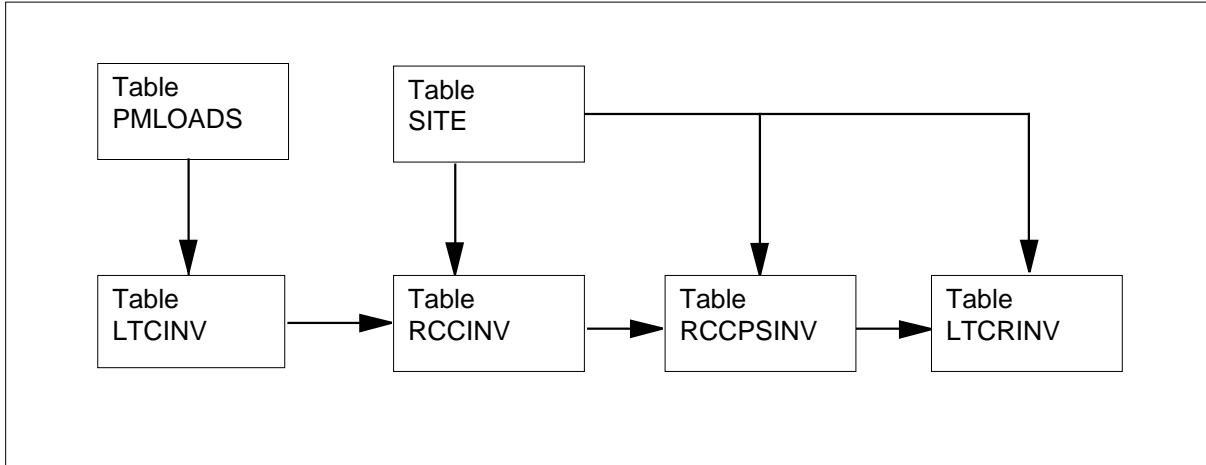
The Subscriber Module SLC-96/Remote translations tables are described in the following list:

- Table PMLOADS stores the device location of every peripheral module (PM) load file in order to map between the load names and devices on which the loads reside. The PM load files must be datafilled in table PMLOADS before they can be used in the inventory tables.
- Table SITE identifies the equipment for the switching unit and for all remote locations that home on to it. This table must be datafilled before any LEN can be assigned or a PM can be datafilled. The host switching unit is the first entry in field NAME, then field LTDSN is associated with the number required to dial the site and alarm data for remote sites. Table SITE uses the same CLLI tuple for operator verification as the one datafilled in table CLLI.
- Table LTCINV contains the inventory data, except the P-side link assignment, for PM types. This table is used to define the line trunk controller (LTC)/line group controller (LGC) on the C-side of the RCC2. Load information for this table is datafilled in field LOAD and corresponds to the LOADNAME tuple from table PMLOADS.
- Table RCCINV maintains a list of RCC2s that are datafilled in the Digital Multiplex System (DMS) and contains inventory data (except P-side link assignments) for the RCC2s. The table information identifies where the RCC2 is located, the load and exec lineups required, and the network link connections. C-side digital signal 1 (DS-1) assignments for the RCC2 are datafilled in table RCCINV. In addition, intraswitching is datafilled in table RCCINV.
- Table RCCPSINV contains only the P-side link assignments for the RCC2. When a tuple is added in table RCCINV, a corresponding tuple is added automatically in table RCCPSINV. This table uses field LOAD to identify load information (LOAD corresponds to the LOADNAME tuple from table PMLOADS). Field CARRIDX indexes into table CARRMTC for maintenance control information about peripheral. Also, the RCCNAME tuple in table RCCPSINV corresponds to the RCCNAME tuple from table RCCINV and stores site information (originally entered in field NAME from table SITE) the PM type, and PM number.
- Table LTCRINV stores data for a select group of new peripherals. Currently, the SMS-R is the only peripheral supported by this table. Table LTCRINV is modified to permit an RCC2 as a host node for a SMS-R.

The Subscriber Module SLC-96/Remote translation process is shown in the flowchart that follows.

Subscriber Module SLC-96/Remote (continued)

Table flow for Subscriber Module SLC-96/Remote



Limitations and restrictions

The following limitations and restrictions apply to Subscriber Module SLC-96/Remote:

- The SMS-R must be provisioned off a DS30A link.
- DS30A links are provisioned on RCC2 ports 22-53.
- In a dual RCC2 (DRCC2) configuration, only RCC2s are connected. No other type of remote cluster controller (RCC) PM is connected.
- A maximum of 14 interlinks are defined on an RCC2.

Interactions

Subscriber Module SLC-96/Remote has no functionality interactions.

Activation/deactivation by the end user

Subscriber Module SLC-96/Remote requires no activation or deactivation by the end user.

Billing

Subscriber Module SLC-96/Remote does not affect billing.

Station Message Detail Recording

Subscriber Module SLC-96/Remote does not affect Station Message Detail Recording.

Datafilling office parameters

Subscriber Module SLC-96/Remote does not affect office parameters.

Subscriber Module SLC-96/Remote (continued)

Datavill sequence

The following table lists the tables that require datavill to implement Subscriber Module SLC-96/Remote. The tables are listed in the order in which they are to be datavilled.

Datavill tables required for Subscriber Module SLC-96/Remote

Table	Purpose of table
SITE	Site. Contains data that allows the DMS system to recognize the equipment for the switching unit and for all remote locations that home on to it.
PMLOADS	Peripheral Module Loads. Stores the device location of every PM load file in order to map between the load names and devices on which the loads reside. This permits autoloading to locate load files without the intervention of operating company personnel. The XPM load files must be datavilled in table PMLOADS before they can be used in the XPM inventory tables.
LTCINV	Line Trunk Controller Inventory. Contains the inventory data, except the P-side link assignments, for PM types. This table is used to define the LTC/LGC on the C-side of the RCC2.
RCCINV	Remote Cluster Controller Inventory. Contains RCC2 inventory data (except P-side link assignments). RCC2 C-side DS-1 assignments are datavilled in table RCCINV.
RCCPSINV	Remote Cluster Controller P-side link Inventory. Contains only RCC2 P-side link assignments.
LTCRINV	Line Trunk Controller Remote Inventory. Contains information about the remote node, its host node, and the connectivity of the communication links between these two nodes. These links are referred to as the C-side links of the remote XPM.

Datavilling table SITE

Table SITE contains data for the switching unit and for all remote locations that home on to it. Before a line equipment number can be assigned and before a PM can be datavilled, table SITE must be datavilled to enable the DMS system to recognize the equipment.

The first entry in table SITE must be HOST for the host switching unit. The site names for the remote locations are defined by the operating company.

The following table shows the datavill specific to Subscriber Module SLC-96/Remote for table SITE. Only those fields that apply directly to

Subscriber Module SLC-96/Remote (continued)

Subscriber Module SLC-96/Remote are shown. Refer to the *Translations Guide* for a description of the other fields.

Note: To use site names for a remote location, ensure that table OFCOPT (USINGSITE) and table OFCENG (UNIQUE_BY_SITE_NUMBERING) are correctly datafilled with both parameters set to Y.

Datafilling table SITE

Field	Subfield or refinement	Entry	Explanation and action
SITE		alphanumeric (4 characters maximum)	Site name. Enter the site name assigned to the remote switching unit. The first character must be alphabetic. PM type names cannot be used for site names. Note: The first entry in this field is for the host switching unit.
Note: Memory is automatically allocated for a maximum of 32 sites.			

Datafill example for table SITE

The following example shows sample datafill for table SITE.

MAP display example for table SITE

```

Table: SITE

NAME LTDSN  MODCOUNT  OPVRCLLI  ALM  TM  TM  TM  POINT  CONTMARK
-----
HOST 00      0           VER90
CARY 02      2           RMMVER90  CR   RSM  0  4    0      +
                               MJ   RSM  0  4    1      +
                               MN   RSM  0  4    2      $
    
```

Datafilling table PMLOADS

Table PMLOADS stores the device location of every PM loadfile which allows the XPM automatic loading feature to locate load files without user intervention.

Table PMLOADS lists active and a backup loadfiles. The active loadfile is always the default load used with the LOADPDM command and most system activities. The backup loadfile is used if there is a problem in loading or returning to service the active loadfile. The backup loadfile is always the unpatched loadfile Northern Telecom provides. Active and backup loadfiles

Subscriber Module SLC-96/Remote (continued)

are used when patches are applied and removed. Table PMLOADS stores data for

- the name of the active loadfile, which is the default load used with the LOADPDM command and most system initiated activities
- the name of the backup loadfile, which is the load used if there is a problem in loading or returning to service the active loadfile. The backup loadfile is always the unpatched loadfile shipped with the SMS.
- the file locations
- the update active loadfile field, which indicates if the site wants the active fileid updated automatically. The feature allows the patched loadfile to be loaded into the XPM if a reload becomes necessary, which simplifies reload and recovery of the XPM. Active file information is updated through loadfile patching, if loadfile patching is enabled.

Active and backup files are used by the system as part of loading and recovery. XPM load files must be datafilled in table PMLOADS before they can be datafilled in table LTCINV. Table LTCINV enforces this rule.

Note: An exception to this rule occurs during initial datafill, and during dump and restore. During these times, tuples in table PMLOADS are automatically datafilled when LTCINV tuples are datafilled.

Prepatched XPM loads

Prepatched XPM loads background

Prepatched XPM loads (PPXLs) are XPM loadfiles with corrective patches built into the loadfile. PPXLs are incremental loads built using patch updates. The patch updates were originally used to create patch files which have been released to the field. Therefore, no functional or technical difference exists between a regular XPM load with patches and a PPXL where the patches have been incorporated into the load. PPXLs are analogous to CM loads with patches built in based on date of shipment.

Implementation of PPXLs

At the beginning of each PPXL loadfile, there resides a 1K data block containing the patch IDs for the patches included in the PPXL. Even though the patches are built into the PPXL, corresponding patch files for each patchid listed in the 1K data block must be present when the PPXL is datafilled in table PMLOADS.

Subscriber Module SLC-96/Remote (continued)

When the PPXL is datafilled in table PMLOADS, the loadset is either modified if one already exists for the base load, or the loadset is initially created if the base load is new to the DMS-100 switch.

Note: Loadsets are used to group all peripheral units loaded with the same load together. To view all loadsets on the DMS-100 switch, access the PATCHER CI level and enter the command INFORM PMALL.

After the PPXL has been added to table PMLOADS, it can be loaded either manually or automatically by the system recovery controller (SRC). After the PPXL is loaded, by either method, the patching performed after loading the PPXL is either reduced or eliminated entirely, because most or all of the patches have already been included in the load.

Once the PPXL is loaded, it can have additional patches applied to it or removed from it exactly in the same fashion as a regular XPM load can. Also, patches built into the PPXL can be removed, as long as their corresponding patch files are present.

Patches added or removed following loading of a PPXL are automatically applied or removed upon subsequent reloads of the PPXL.

PPXL Naming Convention

PPXL file names have *<date>* appended to the end of their corresponding base load name. For example, a PPXL load file created for base load ESA06AS would be named ESA06AS_951023. However, the base load name always remains the same. Base loads can be identified as any load not having the *<date>* suffix.

The inherent value becomes the preservation of the patch stream with the ability to upissue a PPXL as required. A PPXL's vintage can always be identified using the date identifier.

PPXL storage requirements

When preparing to load PPXLs, operating companies are advised to double their XPM load storage requirements to accommodate the PPXLs. PPXLs require that the PPXL loadfile be stored on the ACTVOL device and the base load file be stored on the BKPVOL device.

Loading a PPXL

Two methods are available for adding PPXLs to an office. The first method is for upgrading an office to a new base load lineup, that is, when the base loadname is not currently in table PMLOADS. The second method is for adding PPXLs to offices that already have the base loadname in table

Subscriber Module SLC-96/Remote (continued)

PMLOADS. For example, ESA06AS (the existing loadname) is appended to ESA06AS_951023 (the PPXL added to the baseload).

Note 1: PPXLs are only supported on BCS36 or higher CM loads.

Note 2: PATCH JCK19 must be applied to the CM before continuing.

To load a PPXL in an office where the baseload is new to the office, use the following procedure.

Upgrading the base load

At the MAP terminal

- 1 Copy the base and PPXL loadfiles to disk volumes for PM loads.
 - Note:** Both base and PPXL loads should be copied to two disk volumes for redundancy.
- 2 Copy patches associated with the PPXL loads to the same disk volume used in step 1. A list of patches associated with each PPXL load is included in the load tape shipment. After the PPXL file is present on disk, obtain a list of patches included in the PPXL by entering


```
>XPMLFP
>PATCHLIST FILE ppxl_filename
```

where

ppxl_filename
is the filename of the PPXL loaded added to the base load
- 3 Add a new tuple for the base load to table PMLOADS. Enter the base load for the LOADNAME, the base load name for the ACTFILE and the base load name again for the BKPFIL.
- 4 Add the base loadname to the appropriate inventory table, for example LTCINV.
- 5 Edit the tuple added in step 3 to change the ACTFILE field from the base loadfile name to the PPXL filename. See the datafill example for table PMLOADS to see what this tuple looks like.
- 6 Set the loadset against both units of the XPM by entering


```
>PATCHER
>SET loadname PM pm_type device_no unit_no
```

where

loadname
is the name of the loadfile

pm_type
is the type of PM requiring the loadset

device_no
is the device number with a range of 0-255

unit_no
is the unit number, 0 or 1

Subscriber Module SLC-96/Remote (continued)

- 7 Load the PPXL into each unit of the XPM by entering

```
>BSY UNIT unit_no
>LOADPM UNIT unit_no
>RTS UNIT unit_no
```

where

unit_no

is the unit number of the XPM to be loaded

- 8 Perform a SWACT of the XPM and repeat step 7.

Note 1: Once loaded, the XPM can have additional patches applied or removed in the same manner used with XPM loads in the past. Any patches built into the PPXL can be removed from the load as long as the actual patch file is present on disk.

Note 2: Patches added or removed following the loading of a PPXL are automatically applied or removed upon subsequent reloads of the PPXL.

Note 3: Non-PPXL patches are not removed when the PPXL is reloaded, since the removed patches are already out of the loadset.

To add PPXLs to an existing XPM load lineup, use the following procedure.

Adding PPXLs to an existing PM load lineup

AT the MAP terminal

- 1 Verify all patch_ids associated with the PPXL are on the disk volume identified in table PMLOADS, field ACTVOL. If not present, copy the patches from tape to the correct volume. A list of patches in each PPXL is included with the PM tape shipment. Once the PPXLs are copied to disk, list the patches in the PPXL by entering

```
>XPMLFP
>PATCHLIST FILE ppxl_filename
```

where

ppxl_filename

is the filename of the PPXL loaded to disk

- 2 Copy the PPXL file (filename_date) to the disk volume used in step 1.
- 3 Copy the baseload to the disk volume identified in table PMLOADS, field BKPVOL.
- 4 Modify table PMLOADS as follows: If the XPM base loadname does not exist in table PMLOADS, add a new tuple using the previous "Upgrading baseload lineup" procedure. Otherwise, change field ACTFILE to the PPXL filename (filename_date). The loadset is either upgraded if one currently exists or created if one does not.
- 5 Set the loadset against both units of the XPM by entering
- ```
>PATCHER
>SET loadname PM pm_type device_no unit_no
```

---

**Subscriber Module SLC-96/Remote** (continued)

---

where

**loadname**

is the name of the loadfile

**pm\_type**

is the type of PM requiring the loadset

**device\_no**

is the device number with a range of 0-255

**unit\_no**

is the unit number, 0 or 1

- 6 Each unit of the XPM can be loaded with the PPXL by entering

```
>BSY UNIT unit_no
```

```
>LOADPM UNIT unit_no
```

```
>RTS UNIT unit_no
```

where

**unit\_no**

is the unit number of the XPM to be loaded

- 7 Perform a SWACT of the XPM and repeat step 6.

**Note 1:** Once loaded, the XPM can have additional patches applied or removed in the same manner used with XPM loads in the past. Patches built into the PPXL can be removed from the load if the actual patch file is on disk.

**Note 2:** Patches added or removed following loading of a PPXL are automatically applied or removed during subsequent reloads of the PPXL.

The following table shows the datafill specific to Subscriber Module SLC-96/Remote for table PMLOADS. Only those fields that apply directly to Subscriber Module SLC-96/Remote are shown.

**Datafilling table PMLOADS (Sheet 1 of 2)**

| Field    | Subfield or refinement | Entry                                    | Explanation and action                                                                                                                                                                      |
|----------|------------------------|------------------------------------------|---------------------------------------------------------------------------------------------------------------------------------------------------------------------------------------------|
| LOADNAME |                        | alphanumeric<br>(up to 8<br>characters)  | Peripheral module load name. Enter the XPM load file name.                                                                                                                                  |
| ACTFILE  |                        | alphanumeric<br>(up to 32<br>characters) | Active load file name. The name of the active XPM loadfile (original or patched loadfile (PPXL)).                                                                                           |
| ACTVOL   |                        | alphanumeric<br>(up to 16<br>characters) | Active volume. Identifies the device where the active loadfile is stored. Range: the set of disk drive unit (DDU) volumes and system load module (SLM) disks available to the CM (S00DXPM). |

**Subscriber Module SLC-96/Remote** (continued)

**Datafilling table PMLOADS (Sheet 2 of 2)**

| Field  | Subfield or refinement | Entry                              | Explanation and action                                                                                                                    |
|--------|------------------------|------------------------------------|-------------------------------------------------------------------------------------------------------------------------------------------|
| BKPFIL |                        | alphanumeric (up to 32 characters) | Backup load file name. Identifies backup XPM loadfile name. It should be the same name as field LOADNAME.                                 |
| BKPVOL |                        | alphanumeric (up to 16 characters) | Backup volume. The device where the backup loadfile is stored. Range: the set of DDU volumes and SLM disks available to the CM (S00DXPM). |
| UPDACT |                        | alphanumeric                       | Update active filename. Currently not used. Default value: N.                                                                             |

**Datafill example for table PMLOADS**

The following example shows sample datafill for table PMLOADS.

**MAP display example for table PMLOADS**

| LOADNAME | ACTFILE | ACTVOL  | BKPFIL | BKPVOL | UPDACT |
|----------|---------|---------|--------|--------|--------|
| -----    |         |         |        |        |        |
| ESA06AS  |         |         |        |        |        |
| ESA06AS  |         | S00DXPM |        |        |        |
| ESA06AS  |         | S00DXPM |        |        | Y      |

**Datafilling table LTCINV**

Table Line Trunk Controller Inventory (LTCINV) contains the inventory data, except the P-side link assignment, for PM types LTC, digit trunk controller (DTC), LGC, subscriber module rural (SMR), subscriber module SLC-96 (SMS), subscriber module urban (SMU), and international digital trunk controller (IDTC). For RSC-S, this table defines the LTC/LGC on the C-side of the RCC2.

The following table shows the datafill specific to Subscriber Module SLC-96/Remote for table LTCINV. Only those fields that apply directly to



## Subscriber Module SLC-96/Remote (continued)

Subscriber Module SLC-96/Remote are shown. Refer to the *Translations Guide* for a description of the other fields.

### Datafilling table LTCINV for Subscriber Module SLC-96/Remote

| Field    | Subfield or refinement | Entry        | Explanation and action                                                                                                                                                           |
|----------|------------------------|--------------|----------------------------------------------------------------------------------------------------------------------------------------------------------------------------------|
| FRTYPE   |                        | LTE or LGC   | Frame type. Enter LTE for the LTC; enter LGE for the LGC.                                                                                                                        |
| PECS6X45 |                        | alphanumeric | 6X45 equipment PECS. One PEC is required for each LTC unit. Enter the PEC for unit 0 first. The PEC must reflect minimum firmware capabilities in each unit's processor complex. |

### Datafill example for table LTCINV

The following example shows sample datafill for table LTCINV.

### MAP display example for table LTCINV

```

Table: LTCINV

LTCNAME FRTYPE FRNO SHPOS FLOOR ROW FRPOS EQPEC LOAD

LTC 1 LTE 0 18 0 C 6 6X02NA ELT36xx

EXECTAB CONTMARK
(POTS POTSEX)(KEYSET KSETEX)(RMM_TERM RSMEX)(ABTRK DTCEX) $

CSLNKTAB CONTMARK
(0 17)(1 61)(0 14)(1 29)(0 30)(1 31)(0 28)(1 29) $

OPTCARD CMRLOAD CONTMARK
(MSGMX76 HOST) $ (7X05AA 7) $

TONESET PECS6X45 E2LOAD OPATTR PEC6X40

NORTHAM MX77AA MX77AA MX77NH08 $ 6X40AA

```

**Note:** xx in field LOAD stands for two letters, for example BZ.

### Datafilling table RCCINV

The following table shows the datafill specific to Subscriber Module SLC-96/Remote for table RCCINV. Only those fields that apply directly to

**Subscriber Module SLC-96/Remote** (continued)

Subscriber Module SLC-96/Remote are shown. Refer to the *Translations Guide* for a description of the other fields.

Table Remote Cluster Controller Inventory (RCCINV) contains inventory data, except P-side link assignments, for the RCC2. The C-side DS-1 assignments for the RCC2 are datafilled in table RCCSINV.

**Datafilling table RCCINV**

| Field   | Subfield or refinement | Entry         | Explanation and action                                                                        |
|---------|------------------------|---------------|-----------------------------------------------------------------------------------------------|
| RCCNAME |                        | see subfields | RCC2 name. Subfields: SITE, PMTYPE, and RCCNO.                                                |
|         | SITE                   | alphanumeric  | Site. Enter the site name assigned to the remote location (should also appear in table SITE). |
|         | PMTYPE                 | RCC2          | PM type. Enter RCC2.                                                                          |
|         | RCCNO                  | numeric       | RCC2 number (unique by office, not by site).                                                  |

**Note:** When datafilling field C-side link table (CSLNKTAB), assure message links are not assigned to the same physical interface card. When the interface card supports two or more links, separate the message links by the number of links on the interface cards. This applies to all interface link types; DS-1, DS30, DS30A, or PCM-30. Table control will issue a warning if an attempt is made to assign message links on the same interface card. Assigning message links to the same interface card can cause an E1 outage (failure of all message links) if the card fails.

**Datafill example for table RCCINV**

The following examples show sample datafills for table RCCINV for both an RCC2 provisioned with the NTMX77AA UP and an RCC2 provisioned with the optional NTAX74AA CAP, respectively.

---

**Subscriber Module SLC-96/Remote** (continued)
 

---

**MAP display example for table RCCINV datafilled for NTMX77AA UP**

| Table: RCCINV                                                      |          |         |           |         |           |                          |          |          |          |    |  |          |
|--------------------------------------------------------------------|----------|---------|-----------|---------|-----------|--------------------------|----------|----------|----------|----|--|----------|
| RCCNAME                                                            | FRTYPE   | FRNO    | SHPOS     | FLOOR   | ROW       | FRPOS                    | EQPEC    | LOAD     |          |    |  |          |
| CARY                                                               | RCC2     | 0       |           |         |           |                          |          |          |          |    |  |          |
|                                                                    | 1101     | CRSC    | 0         | 5       | 0         | C                        | 0        | MX85AA   | CRI08xx  |    |  |          |
| EXECTAB                                                            |          |         |           |         |           |                          |          |          | CONTMARK |    |  |          |
| (POTS POTSEX) (KEYSET KSETEX) (RMM_TERM RSMEX) (ESALINES ESAEX) \$ |          |         |           |         |           |                          |          |          |          |    |  |          |
| CSPM                                                               |          |         |           |         |           |                          |          |          | CSLNKTAB |    |  | CONTMARK |
| LTC                                                                | 1        | (0)     | (1)       | (2)     | (3)       | (4)                      | (5)      | (6)      | (7)      | \$ |  |          |
| ESA                                                                | INTRASW  | OPTCARD |           | CMRLOAD |           |                          |          | CONTMARK |          |    |  |          |
| Y                                                                  | Y        | (UTR6)  | (NT7X05AA | 7)      | (MSG6X69) | (CMR5                    | CMRAG03) | (ISP16)  | \$       |    |  |          |
| TONESET                                                            | PECS6X45 |         |           | E2LOAD  |           |                          | EXTINFO  |          |          |    |  |          |
| NORTHAM                                                            | MX77AA   | MX77AA  | MX77xxxx  |         |           | CEXT 0 4 0 E 15 MX86AA L |          |          |          |    |  |          |

**Note 1:** xx in field LOAD and xxxx in field E2LOAD represent alphanumeric entries, for example B1 and XE01, respectively.

**Note 2:** If the shelf is equipped with a processor other than NTMX77 or the optional NTAX74, field E2LOAD is automatically datafilled with value NILLOAD.

**Note 3:** NTMX77 UP is required to support NT7X05 functionality. The optional NTAX74 CAP does not support NT7X05 PRL functionality. When a user attempts to datafill field PECS6X45 with AX74AA AX74AA instead of MX77AA MX77AA when NT7X05 is already datafilled as an optional card, the tuple change is disallowed and the MAP displays the following message:

Info: NT7X05AA requires MX77 processor

**Note:** When field PECS6X45 is datafilled with AX74AA AX74AA instead of MX77AA MX77AA, the load name prefix in field LOAD changes from CRI to XRI. For example, CRI08xx (for MX77) changes to XRI08XX (for AX74AA). The following example shows sample datafill for table RCCINV when the RCC2 is datafilled for the NTAX74AA CAP.

**Subscriber Module SLC-96/Remote** (continued)

**MAP display example for table RCCINV datafilled for NTAX74AA CAP**

```

Table: RCCINV
RCCNAME FRTYPE FRNO SHPOS FLOOR ROW FRPOS EQPEC LOAD

CARY RCC2 0
 1101 CRSC 0 5 0 C 0 MX85AA XRI08xx
EXECTAB
(POTS POTSEX) (KEYSET KSETEX) (RMM_TERM RSMEX) (ESALINES ESAEX) $
CSPM CSLNKTAB
LTC 1 (0) (1) (2) (3) (4) (5) (6) (7) $
ESA INTRASW OPTCARD CMRLOAD CONTMARK
Y Y (UTR6) (MSG6X69) (CMR5 CMRAG03) (ISP16) $
TONESET [PECS6X45] [E2LOAD] EXTINFO
NORTHAM [AX74AA AX74AA] [AX74xxxx] CEXT 0 4 0 E 15 MX86AA L

```

**Datafilling table RCCPSINV**

Table Remote Cluster Controller P-side link Inventory (RCCPSINV) contains only the P-side link assignments for the RCC2. Up to 54 (0-53) multiples of P-side link information may be datafilled for the RCC2.

The following table shows the datafill specific to Subscriber Module SLC-96/Remote for table RCCPSINV. Only those fields that apply directly to

---

**Subscriber Module SLC-96/Remote** (continued)

---

Subscriber Module SLC-96/Remote are shown. Refer to the *Translations Guide* for a description of the other fields.

**Datafilling table RCCPSINV**

| Field                                                                                                                                                                                                        | Subfield or refinement | Entry         | Explanation and action                                                                                                                                                                   |
|--------------------------------------------------------------------------------------------------------------------------------------------------------------------------------------------------------------|------------------------|---------------|------------------------------------------------------------------------------------------------------------------------------------------------------------------------------------------|
| RCCNAME                                                                                                                                                                                                      |                        | see subfields | RCC2 name. Enter the name of the RCC2. Subfields: SITE, PMTYPE, and RCCNO.                                                                                                               |
|                                                                                                                                                                                                              | SITE                   | alphanumeric  | Site. Enter the site name assigned to the remote location. It should also appear in table SITE.                                                                                          |
|                                                                                                                                                                                                              | PMTYPE                 | RCC2          | PM type. Enter RCC2 for the non-ISDN RCC2.                                                                                                                                               |
|                                                                                                                                                                                                              | RCC2NO                 | 0-127         | RCC2 number.                                                                                                                                                                             |
| PSLINKTAB                                                                                                                                                                                                    |                        | 0-20          | P-side link table. Subfields: PSLINK, PSDATA, and CONTMARK. Enter the vector number.<br><br><b>Note:</b> Changes to fields with multiple entries should be made in the PROMPT mode only. |
|                                                                                                                                                                                                              | PSLINK                 | 0-53          | P-side link. Enter the P-side port number of the RCC2.                                                                                                                                   |
|                                                                                                                                                                                                              | PSDATA                 | alphanumeric  | P-side data. Enter DS-1 for links to remote-off-remote. DS30A for links to RMMs or LCMs. Otherwise, enter NILTYPE.                                                                       |
| CARRIDX                                                                                                                                                                                                      |                        | character     | Carrier index. Enter the name to index into table CARRMTC. Enter a blank for the default template in table CARRMTC.                                                                      |
| ACTION                                                                                                                                                                                                       |                        | Y             | Action. Enter Y if the carrier should be removed from service when the OOS limit for frame, slip, errored-second, or severe errored-second is exceeded.                                  |
| <b>Note:</b> PSDATA fields are datafilled according to the AREASELCT value. If AREASELCT is DS30A, DCH, or NILTYPE, no other fields require datafill. If PSDATA is DS-1, complete fields CARRIDX and ACTION. |                        |               |                                                                                                                                                                                          |

**Datafill example for table RCCPSINV**

The following example shows sample datafill for table RCCPSINV.

**Subscriber Module SLC-96/Remote** (continued)**MAP display example for table RCCPSINV**

```

Table: RCCPSINV

RCCNAME PSLNKTAB

CARY RCC2 0 (0 DS-1 DEFAULT N)(1 DS-1 DEFAULT N)
(2 DS-1 DEFAULT N)(3 DS-1 DEFAULT N)(4 DS-1 DEFAULT N)
(5 DS-1 DEFAULT N)(6 DS-1 DEFAULT N)(7 DS-1 DEFAULT N)
(8 DS-1 DEFAULT N)(9 DS-1 DEFAULT N)(10 DS-1 DEFAULT N)
(11 DS-1 DEFAULT N)
...
...
(21 NILTYPE) (22 NILTYPE) (23 NILTYPE) (24 NILTYPE)
(25 NILTYPE) (26 NILTYPE) (27 NILTYPE) (28 NILTYPE)
(29 NILTYPE)
...
...
... $

```

**Datafilling table LTCRINV**

Table LTC Remote Inventory (LTCRINV) stores data for a select group of new peripherals. The SMS-R is the only new peripheral supported by this table. Table LTCRINV is modified to permit an RCC2 as a host node for an SMS-R.

The following table shows the datafill specific to Subscriber Module SLC-96/Remote for table LTCRINV. Only those fields that apply directly to

---

**Subscriber Module SLC-96/Remote** (continued)

---

Subscriber Module SLC-96/Remote are shown. Refer to the *Translations Guide* for a description of the other fields.

**Datafilling table LTCRINV**

| Field                                                                                                                                                                                                                                                                                                                                                                                                                                                                                                                                                                                              | Subfield or refinement | Entry        | Explanation and action                                                          |
|----------------------------------------------------------------------------------------------------------------------------------------------------------------------------------------------------------------------------------------------------------------------------------------------------------------------------------------------------------------------------------------------------------------------------------------------------------------------------------------------------------------------------------------------------------------------------------------------------|------------------------|--------------|---------------------------------------------------------------------------------|
| CSPM                                                                                                                                                                                                                                                                                                                                                                                                                                                                                                                                                                                               |                        | alphanumeric | C-side peripheral module (PM). Enter the name of the C-side host PM.            |
|                                                                                                                                                                                                                                                                                                                                                                                                                                                                                                                                                                                                    | SITE                   | character    | Site. The site name from table SITE.                                            |
|                                                                                                                                                                                                                                                                                                                                                                                                                                                                                                                                                                                                    | PMT                    | alphanumeric | External peripheral module type. Enter the name of the C-side host PM type.     |
|                                                                                                                                                                                                                                                                                                                                                                                                                                                                                                                                                                                                    | XPMNO                  | numeric      | External peripheral module number. Enter the number of the node in the PM type. |
| <p><b>Note:</b> When datafilling field C-side link table (CSLNKTAB), assure message links are not assigned to the same physical interface card. When the interface card supports two or more links, separate the message links by the number of links on the interface cards. This applies to all interface link types; DS-1, DS30, DS30A, or PCM-30. Table control will issue a warning if an attempt is made to assign message links on the same interface card. Assigning message links to the same interface card can cause an E1 outage (failure of all message links) if the card fails.</p> |                        |              |                                                                                 |

**Datafill example for table LTCRINV**

The following example shows sample datafill for table LTCRINV.

**Subscriber Module SLC-96/Remote** (continued)

**MAP display example for table LTCRINV**

| LTCRNAME    | FRTYPE   | FRNO          | SHPOS   | FLOOR    |
|-------------|----------|---------------|---------|----------|
| CARY SMSR 2 | LTE      | 0             | 0       | 0        |
| ROW         | FRPOS    | EQPEC         | LOAD    | CONTMARK |
| A           | 0        | 6X02PA        | SSR36xx | \$       |
| CSPM        | CSLNKTAB | CONTMARK      |         |          |
| CARY RCC2 0 | (0 0)    | (1 1)         | (0 2)   | (1 3) \$ |
| OPTCARD     | CONTMARK | PECSX45       |         |          |
| MX76LOC     | \$       | MX77AA MX77AA |         |          |

**Note:** xx in field LOAD stands for two letters, for example BZ.

**Error messages for table LTCRINV**

The following error messages apply to table LTCRINV.

|                                                |
|------------------------------------------------|
| PROCESSING ERROR<br>UNEXPECTED ERROR CONDITION |
|------------------------------------------------|

**Error messages for table LTCRINV (Sheet 1 of 5)**

| Error message                                      | Explanation and action                                                                                                                                  |
|----------------------------------------------------|---------------------------------------------------------------------------------------------------------------------------------------------------------|
| Load file SMX26AU is not equipped in table PMLOADS | The load file specified in the tuple must exist in table PMLOADS.<br><br>Add the load file to table PMLOADS, or use one of the load files in the table. |
| Maximum of four C-side links permitted on SMS-R    | SMS-R only supports a maximum of four C-side links.<br><br>Try the add/change again and do not specify more than four C-side links.                     |



**Subscriber Module SLC-96/Remote** (continued)**Error messages for table LTCRINV (Sheet 2 of 5)**

| Error message                                 | Explanation and action                                                                                                                                                                                                                                                                                                                                                                                       |
|-----------------------------------------------|--------------------------------------------------------------------------------------------------------------------------------------------------------------------------------------------------------------------------------------------------------------------------------------------------------------------------------------------------------------------------------------------------------------|
| Ports 0 and 2 must be datafilled for SMS-R.   | <p>C-side ports 0 and 2 are message ports for the SMS-R.</p> <p>These two ports must be equipped as C-side links. Ports 1 and 3 are optional. If port 1 is not desired, it must be datafilled as NILPORT in order to datafill port 2.</p> <p>Try the add/change again and ensure at least C-side ports 0 and 2 are datafilled, and port 1 is datafilled or set to NILPORT if it is not to be configured.</p> |
| RCC2 P-side ports not equipped as DS30A link. | <p>Links connecting the SMS-R and RCC2 must be DS30A links. At least one of the RCC2 P-side ports specified is equipped as some other link type.</p> <p>Position on the C-side RCC2 in table RCCPSINV and find an available port that is of type DS30A.</p>                                                                                                                                                  |
| Duplicate C-side links entered.               | <p>One or more RCC2 P-side ports specified has been used more than once.</p> <p>Try the add/change again and make sure that the links specified are not duplicated.</p>                                                                                                                                                                                                                                      |
| PM not offline.                               | <p>An attempt has been made to delete the tuple of a peripheral that is not offline.</p> <p>Post the peripheral and place it in the offline state, then try the deletion again.</p>                                                                                                                                                                                                                          |
| Failed to allocate variant data.              | <p>A problem has been encountered while trying to allocate store for the peripheral 's variant data.</p> <p>Try the add/change command again, if the problem persists contact ETAS.</p>                                                                                                                                                                                                                      |
| Failed to deallocate variant data.            | <p>A problem has been encountered while trying to deallocate store for the peripheral's variant data due to the deletion of the variant data.</p> <p>If this problem persists when a tuple is deleted, contact ETAS.</p>                                                                                                                                                                                     |

**Subscriber Module SLC-96/Remote** (continued)

**Error messages for table LTCRINV (Sheet 3 of 5)**

| Error message                                                              | Explanation and action                                                                                                                                                                                                                                                                                                                                                  |
|----------------------------------------------------------------------------|-------------------------------------------------------------------------------------------------------------------------------------------------------------------------------------------------------------------------------------------------------------------------------------------------------------------------------------------------------------------------|
| Host node's port 5 already equipped with another node.                     | <p>The host's port specified to be connected to the peripheral's C-side is already used by another peripheral.</p> <p>Choose another host port which is not being used.</p>                                                                                                                                                                                             |
| Host's node port 7 must be Manbusy or PM offline/manbusy for link changes. | <p>The port specified to be deleted from the peripheral C-side links, is not manually busy or offline, or the peripheral having this link as a C-side link is not manually busy or offline.</p> <p>Post the host peripheral and insure the port is in one of these states, or the peripheral is in one of the valid states before the operation is attempted again.</p> |
| Data store is not available.                                               | <p>A problem has been encountered while attempting to allocate store for an internal structure.</p> <p>Try the add command again, if the problem persists contact ETAS.</p>                                                                                                                                                                                             |
| Data store is lost.                                                        | <p>While attempting to access an internal structure of the peripheral for updating, an inconsistency has been encountered.</p> <p>Try the change command again. If the problem persists, check for possible LOGS, contact ETAS if needed.</p>                                                                                                                           |
| Could not find the host node.                                              | <p>The host peripheral does not exist.</p> <p>Check the host peripheral 's inventory table and apply the correction.</p>                                                                                                                                                                                                                                                |
| PMTYPE not supported by this table. Those currently supported are SMS-R.   | <p>PMTYPE entered is not valid for this table.</p> <p>Ensure PMTYPE entered is one of the supported peripheral modules (PM).</p>                                                                                                                                                                                                                                        |
| PM must be remote.                                                         | <p>HOST is entered as the site name of the peripheral. The site name must be a valid remote site.</p> <p>Refer to table SITE for available remote sites.</p>                                                                                                                                                                                                            |

---

**Subscriber Module SLC-96/Remote** (continued)

---

**Error messages for table LTCRINV (Sheet 4 of 5)**

| Error message                                      | Explanation and action                                                                                                                                                                                                                            |
|----------------------------------------------------|---------------------------------------------------------------------------------------------------------------------------------------------------------------------------------------------------------------------------------------------------|
| PM must be unique by office.                       | <p>The PM number of the peripheral must be unique per office until the site is fully supported.</p> <p>Ensure PM number is unique for that PMTYPE, retry table operation.</p>                                                                     |
| SMS-R allowed on RCC/RCC2 P-side only.             | <p>The host specified for an SMS-R must be an RCC/RCC2.</p> <p>Make this correction and attempt table operation again.</p>                                                                                                                        |
| Must have NIL P-side links prior to deleting node. | <p>A peripheral cannot be deleted, until all its P-side links in table LTC Remote P-Side Inventory (LTCRPSINV) are set to NILTYPE.</p> <p>Ensure all the peripheral's P-side links are set to NILTYPE before the deletion is attempted again.</p> |
| C-side link info failure-check logs.               | <p>A problem has been encountered while defining the C-side links to the input/output system.</p> <p>Try table operation again. Check for possible logs, if the problem persists contact ETAS.</p>                                                |
| Failed to allocate temporary store.                | <p>Temporary store needed to process the table request is not available.</p> <p>Try table operation again. If the problem persists contact ETAS.</p>                                                                                              |
| Host node data not available.                      | <p>An internal problem has occurred when accessing the host node's internal data.</p> <p>Try the table operation again. If the problem persists contact ETAS.</p>                                                                                 |
| Invalid host node.                                 | <p>The host node specified does not exist.</p> <p>Choose a configured node for the host node, and perform the table operation again.</p>                                                                                                          |
| RCC2 ports 22 and 23 reserved for RMMs.            | <p>When datafilling an RCC2 as the host node, its P-side ports 22 and 23 are reserved for RMMs only.</p> <p>Choose any of its other available ports.</p>                                                                                          |

---

## Subscriber Module SLC-96/Remote (end)

---

### Error messages for table LTCRINV (Sheet 5 of 5)

| Error message                  | Explanation and action                                                                                                                                                   |
|--------------------------------|--------------------------------------------------------------------------------------------------------------------------------------------------------------------------|
| Invalid PEC.                   | The Product Engineering Code (PEC) specified for the PM is incorrect.<br><br>Enter a valid PEC and perform the table operation again.                                    |
| Add node failed.               | An internal problem is encountered when attempting to add a node to the input/output system.<br><br>Perform the add command again. If the problem persists contact ETAS. |
| Invalid C-side links.          | This error message accompanies a relocate, add, or delete node error.<br><br>Follow the relocate, add, or delete problem action test.                                    |
| Relocate node failed.0         | An internal problem is encountered when relocating the node in the input/output system.<br><br>Retry the add command. If the problem persists contact ETAS.              |
| Delete node failed.            | Due to a delete operation, an internal problem is encountered when deleting a node from the input/output system.                                                         |
| Invalid link to port map data. | Internal data has been corrupted.<br><br>Delete the node and re-add. If the problem persists contact ETAS. See logs for information.                                     |

### Translation verification tools

Subscriber Module SLC-96/Remote does not use translation verification tools.

### SERVORD

Subscriber Module SLC-96/Remote does not use SERVORD.

---

## Enhanced ESA (Lines and Trunks)

---

### Functional group

BAS00012

### Feature package

NTXN82AB RSC Enhanced ESA (Lines and Trunks)

NTXQ12AA RSC Enhanced ESA (Lines)

### Release applicability

BCS34 and up

### Prerequisites

Enhanced ESA (Lines and Trunks) requires the following feature packages:

- NTX000AA Bilge
- NTX001AA Common Basic
- NTX145AA Remote Switching Center
- NTX149AA RSC ESA Operation—Lines

*Note:* Prerequisite packages are identical for packages NTXN82AB and NTXQ12AA, except for packages NTX149AA and NTX149AB. NTX149AA is a prerequisite package for NTXQ12AA. NTX149AB is a prerequisite package for NTXN82AB.

- NTX149AB RSC ESA Operation—Lines and Trunks

*Note:* Prerequisite packages are identical for packages NTXN82AB and NTXQ12AA, except for packages NTX149AA and NTX149AB. NTX149AA is a prerequisite package for NTXQ12AA. NTX149AB is a prerequisite package for NTXN82AB.

- NTX270AA New Peripheral Maintenance Package
- NTX901AA Local Features I

### Description

Warm ESA entry is provided on the single and dual Remote Switching Center-SONET (RSC-S). ESA allows the remote cluster controller 2 (RCC2) to provide local call control service with a minimal feature set during emergency situations. Prior to this capability, the RCC2 provided only cold ESA entry and exit. The RCC2 supports warm ESA entry and forced ESA

## Enhanced ESA (Lines and Trunks) (continued)

---

(FESA), if the RSC-S contains a dual configuration. RCC2 warm ESA entry is based on the remote cluster controller (RCC) warm ESA entry.

Integrated services digital network (ISDN) calls are not supported in ESA. RCC2 ESA warm exit provides call survival for non-ISDN calls.

### Operation

An RCC2 enters ESA under one of the following conditions:

- Both central-side (C-side) messaging links (0 and 2) are out of service.
- One RCC2 in a dual configuration receives a message from its spouse RCC2 to enter ESA. The ESAFORCE option in table IRLNKINV is set to Y(es).
- The RCC2 is forced into ESA by a monitor command.

Warm ESA entry allows stable intraswitched calls to stay active during ESA entry. Host switched calls are dropped. Stable interswitched calls survive ESA entry if the ESAFORCE option in table INLNKINV is set to Y(es), for that dual configuration. ESA warm entry determines if a call is stable. If the call is not stable, it is dropped. If the call is stable, ESA data structures are set up to reflect the call.

Call processing is suspended during ESA warm entry. Stable calls that survive the warm entry process remain in a talking state during the call processing freeze. Dialtone is delayed while the call processing freeze is in effect, when call processing is resumed any line which is offhook during that time receives dialtone. Line-to-line, line-to-trunk, trunk-to-line, and trunk-to-trunk calls are supported by ESA warm entry.

Following are important differences between the RCC2 and the RCC:

- The RCC2 has 54 peripheral side (P-side) links versus 20 P-side links for the RCC.
- Intraswitched calls on the RCC2 use P-side-to-P-side connections, instead of P-side-to-C-side connections in the RCC. No C-side channels are used for intraswitched calls on the RCC2.
- The RCC2 interlinks are P-side-to-P-side; the RCC interlinks are C-side-to-C-side.
- The RCC2 message interlinks are on ports 0 and 8; the RCC message interlinks are on ports 1 and 3.

---

**Enhanced ESA (Lines and Trunks)** (continued)

---

**Translations table flow**

The Enhanced ESA (Lines and Trunks) translations tables are described in the following list:

- Table ESAHNPA contains prefix translation used for normal prefix translation for trunks. The HNPAKEY tuple is indexed by the RTEKEY tuple in table ESARTE to access the route entry.
- Table ESARTE identifies trunks that a call may be routed to during ESA. Field RTEKEY indexes into field HNPAKEY (table ESAHNPA) or field PXLAKKEY (table ESAPXLA) to access the route entry.
- Table TRKMEM lists the data associated with each trunk assigned to one of the trunk groups and subgroups specified in tables TRKGRP and TRKSGRP. This table identifies the circuits associated with static trunks, dynamic trunks, and the test equipment used to test lines and trunks. Field CLLI in table TRKMEM corresponds to the CLLI code for the trunk group.
- Table TRKSGRP lists the supplementary information for each subgroup that is assigned to one of the trunk groups listed in table TRKGRP. Field CLLI in table TRKSGRP corresponds to the CLLI code for the trunk group.
- Table ISTRKGRP controls the dynamic nature of the trunks located on an RCC2. An entry in this table indicates that a trunk group has dynamic capability. Subfield SITE\_ID in table ISTRKGRP corresponds to the NAME tuple from table SITE to identify the equipment for the switching unit and for all remote locations that home on to it. Field ISTRKKEY in table ISTRKGRP corresponds to the CLLI tuple from table CLLI that identifies the trunk group that should be assigned dynamic capability.
- Table TRKGRP defines data for each trunk group associated with the switching unit. Field CLLI in table TRKGRP corresponds to the CLLI code for the trunk group.
- Table CUSTHEAD links a customer group to the prefix translation table name as identified in table ESAPXLA if the translation is performed for a particular IBN customer group. Field XLANAME corresponds to the prefix translator name assigned in field XLANAME from table ESAPXLA to access prefix translation data.
- Table ESAPXLA is used to exceptions rather than normal prefix translation for ESA. Table ESAPXLA contains special prefix translation data used for POTS and IBN customers. The PXLAKKEY tuple is indexed by the RTEKEY tuple in table ESARTE to access the route entry. The NODE tuple in table ESAPXLA correspond to the RCCNAME tuple from

## Enhanced ESA (Lines and Trunks) (continued)

---

table RCCINV to access inventory data (except P-side link assignments) for the identified RCC2.

- Table RCCINV maintains a list of RCC2s that are datafilled in the DMS system and contains inventory data (except P-side link assignments) for the RCC2s. The table information identifies where the RCC2 is located, the load and exec lineups required, and the network link connections. C-side DS-1 assignments for the RCC2 are datafilled in table RCCINV. In addition, intraswitching is datafilled in table RCCINV.

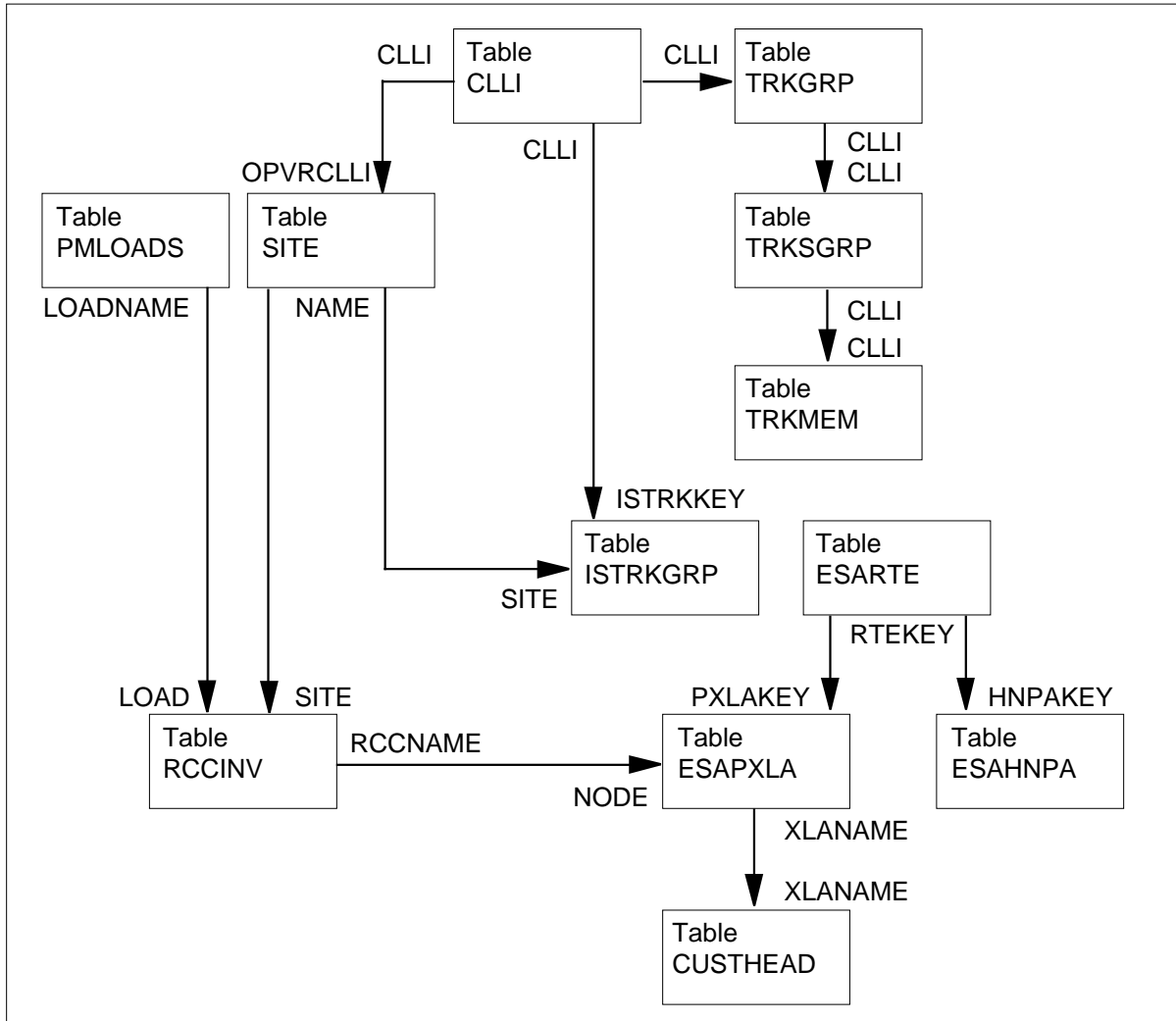
Load information for this table is datafilled in field LOAD and corresponds to the LOADNAME tuple from table PMLOADS. Also, the RCCNAME tuple in table RCCINV corresponds to the NODE tuple from table ESAPXLA. Field RCCNAME stores site information (originally entered in field NAME from table SITE), the PM type, and PM number.

The following flowchart shows the Enhanced ESA (Lines and Trunks) translation process.



## Enhanced ESA (Lines and Trunks) (continued)

**Table flow for Enhanced ESA (Lines and Trunks)**



### Limitations and restrictions

The following limitations and restrictions apply to Enhanced ESA (Lines and Trunks):

- Intraswitched and interswitched calls established during ESA are preserved during warm ESA entry. This includes lines and trunks supported during ESA. If the call type is not supported during ESA, the call is dropped.
- If option ESAFORCE in table IRLNKINV is set to NO, interswitched calls are dropped during warm ESA entry. The state of option ESAFORCE has no effect on intraswitched calls. If option ESAFORCE is set to NO, stable intraswitched calls are preserved during warm ESA entry.

## Enhanced ESA (Lines and Trunks) (continued)

---

- Subscriber Carrier Module-100S Remote (SMS-R) is not supported.
- ISDN calls are not supported.

### Interactions

Enhanced ESA (Lines and Trunks) has no functionality interactions.

### Activation/deactivation by the end user

Enhanced ESA (Lines and Trunks) requires no activation or deactivation by the end user.

### Billing

Enhanced ESA (Lines and Trunks) does not affect billing.

### Station Message Detail Recording

Enhanced ESA (Lines and Trunks) does not affect Station Message Detail Recording (SMDR).

### Datafilling office parameters

The following table shows the office parameters used by Enhanced ESA (Lines and Trunks). For more information about office parameters, refer to *Office Parameters Reference Manual*.

#### Office parameters used by Enhanced ESA (Lines and Trunks)

| Table name | Parameter           | Explanation and action                                                              |
|------------|---------------------|-------------------------------------------------------------------------------------|
| OFCENG     | RSC_ESA_NOTIFY_TONE | Defines whether the subscriber hears a tone burst when ESA is entered. Default: Y.  |
| OFCENG     | RSC_XPMESAEXIT      | This parameter specifies the delay time when C-side message links fail. Default: 6. |
| OFCENG     | RSC_ESASDUPD_BOOL   | Specifies whether nightly updates of static data should be performed. Default: Y.   |
| OFCENG     | RSC_ESASDUP_HOUR    | Specifies the starting time of the daily update of ESA static data. Default: 2.     |

---

## Enhanced ESA (Lines and Trunks) (continued)

---

### Datavfill sequence

The following table lists the tables that require datavfill to implement Enhanced ESA (Lines and Trunks). The tables are listed in the order in which they are to be datavfilled.

#### Datavfill tables required for RSC Enhanced ESA (Lines and Trunks)

| Table    | Purpose of table                                                                                                                                                                                                                       |
|----------|----------------------------------------------------------------------------------------------------------------------------------------------------------------------------------------------------------------------------------------|
| RCCINV   | Remote Cluster Controller Inventory. Contains RCC2 inventory data (except P-side inventory assignments). RCC2 C-side digital signal 1 (DS-1) assignments are datavfilled in table RCCINV.                                              |
| ESAPXLA  | ESA Trunk Translations. Contains translations that support RSC-S line-to-trunk, trunk-to-trunk, and trunk-to-line call processing during ESA. Table ESAPXLA contains special prefix translation data for POTS and IBN customer groups. |
| CUSTHEAD | Customer Group Head. Links a customer group to the prefix translation table name as identified in table ESAPXLA.                                                                                                                       |
| TRKGRP   | Trunk Group. Lists the characteristics of each trunk group.                                                                                                                                                                            |
| ISTRKRP  | RCC Dynamic Trunk Groups. Controls the dynamic nature of RCC2 trunks. An entry in this table indicates that a trunk group has dynamic capability.                                                                                      |
| TRKSGRP  | Trunk Subgroup. Lists supplementary information for each subgroup assigned to one of the trunk groups listed in table TRKGRP.                                                                                                          |
| TRKMEM   | Trunk Member. Contains the address of the actual trunk member. Each RCC2 trunk member has terminal data associated with it.                                                                                                            |
| ESARTE   | Emergency Stand-Alone Routing. Identifies trunks that a call can be routed to during ESA.                                                                                                                                              |
| ESAHNPA  | ESA Home Numbering Plan Area. Allows the subscriber to select one of the trunks referenced in table ESARTE.                                                                                                                            |

### Datavfilling table RCCINV

The Remote Cluster Controller Inventory (RCCINV) table contains RCC2 inventory data, except P-side link assignments. The ESA tuple must be datavfilled as Y(es) to enable ESA.

The following table shows the datavfill specific to Enhanced ESA (Lines and Trunks) for table RCCINV. Only those fields that apply directly to Enhanced

**Enhanced ESA (Lines and Trunks)** (continued)

ESA (Lines and Trunks) are shown. Refer to the *Translations Guide* for a description of the other fields.

**Datafilling table RCCINV for RSC Enhanced ESA (Lines and Trunks)**

| Field                                                                                                                                                                                                                                                                                                                                                                                                                                                                                                                                                                                              | Subfield or refinement | Entry    | Explanation and action                                                                                                                                                                                                                                                                                            |
|----------------------------------------------------------------------------------------------------------------------------------------------------------------------------------------------------------------------------------------------------------------------------------------------------------------------------------------------------------------------------------------------------------------------------------------------------------------------------------------------------------------------------------------------------------------------------------------------------|------------------------|----------|-------------------------------------------------------------------------------------------------------------------------------------------------------------------------------------------------------------------------------------------------------------------------------------------------------------------|
| EXECTAB                                                                                                                                                                                                                                                                                                                                                                                                                                                                                                                                                                                            |                        |          | Executive table. Subfields: TRMTYPE, EXEC, and CONTMARK.<br><br><b>Note 1:</b> More than one combination (8 maximum) can be used for a given PM.<br><br><b>Note 2:</b> Changes to fields with multiple entries should be made in the PROMPT mode only.                                                            |
|                                                                                                                                                                                                                                                                                                                                                                                                                                                                                                                                                                                                    | TRMTYPE                | ESALINES | Terminal type. Enter the type of PM terminals used. Entry values: POTS (regular lines), KEYSET (IBN/data lines), RMM_TERM (RMM terminals), ABTRK (regular trunks) and ESALINES (ESA lines).                                                                                                                       |
|                                                                                                                                                                                                                                                                                                                                                                                                                                                                                                                                                                                                    | EXEC                   | ESAEX    | Executive program. Enter the set of executive programs required for the PM specified in subfield TRMTYPE. Entry values: POTSEX (TRMTYPE is POTS) KSETEX (TRMTYPE is KEYSET), RSMEX (TRMTYPE is RMM_TERM), DTCEX or FXODCM, depending on the type of trunking (TRMTYPE is ABTRK), and ESAEX (TRMTYPE is ESALINES). |
|                                                                                                                                                                                                                                                                                                                                                                                                                                                                                                                                                                                                    | CONTMARK               |          | Continuation mark. Enter a plus sign (+) when the vector continues on the next record. Enter a dollar sign (\$) to show the end of the vector.                                                                                                                                                                    |
| ESA                                                                                                                                                                                                                                                                                                                                                                                                                                                                                                                                                                                                |                        | Y or N   | Emergency Stand Alone. Entry values: Y (the RSC-S has the ESA option) or N (RSC-S does not have the ESA option).                                                                                                                                                                                                  |
| <p><b>Note:</b> When datafilling field C-side link table (CSLNKTAB), assure message links are not assigned to the same physical interface card. When the interface card supports two or more links, separate the message links by the number of links on the interface cards. This applies to all interface link types; DS-1, DS30, DS30A, or PCM-30. Table control will issue a warning if an attempt is made to assign message links on the same interface card. Assigning message links to the same interface card can cause an E1 outage (failure of all message links) if the card fails.</p> |                        |          |                                                                                                                                                                                                                                                                                                                   |

---

**Enhanced ESA (Lines and Trunks) (continued)**


---

**Datafill example for table RCCINV**

The following examples show sample datafills for table RCCINV for both an RCC2 provisioned with the NTMX77AA UP and an RCC2 provisioned with the optional NTAX74AA CAP, respectively.

**MAP display example for table RCCINV**

| Table: RCCINV                                                                 |          |                  |        |       |           |        |                 |          |          |         |
|-------------------------------------------------------------------------------|----------|------------------|--------|-------|-----------|--------|-----------------|----------|----------|---------|
| RCCNAME                                                                       | FRTYPE   | FRNO             | SHPOS  | FLOOR | ROW       | FRPOS  | EQPEC           | LOAD     |          |         |
| CARY                                                                          | RCC2     | 0                | CRSC   | 0     | 18        | 0      | C               | 0        | MX85AA   | CRI08xx |
| EXECTAB                                                                       |          |                  |        |       |           |        |                 |          | CONTMARK |         |
| (POTS POTSEX) (KEYSET KSETEX) (ABTRK DTCEX) (RMM_TERM RSMEX) (ESALINES ESAEX) |          |                  |        |       |           |        |                 |          |          |         |
| \$                                                                            |          |                  |        |       |           |        |                 |          |          |         |
| CSPM                                                                          | CSLNKTAB |                  |        |       |           |        |                 |          | CONTMARK |         |
| LTC                                                                           | 1        | (0)              | (1)    | (2)   | (3)       | (4)    | (5)             | (6)      | (7)      | \$      |
| ESA                                                                           | INTRASW  | OPTCARD          |        |       |           |        | CMRLOAD         | CONTMARK |          |         |
| Y                                                                             | Y        | (UTR6) (MSG6X69) |        |       |           | (7X05) | (CMR18 CMRAG03) |          | (ISP16)  | \$      |
| TOSET                                                                         | PROCPEC  |                  |        |       | E2LOAD    |        |                 |          |          |         |
| NORTHAM                                                                       | MX77AA   |                  | MX77AA |       | MX77Nxxxx |        |                 |          |          |         |

**Note 1:** xx in field LOAD and xxxx in field E2LOAD represent alphanumeric entries, for example B1 and XE01, respectively.

**Note 2:** If the shelf is equipped with a processor other than NTMX77 or the optional NTAX74, field E2LOAD is automatically datafilled with value NILLOAD.

**Note 3:** When field PROCPEC is datafilled with AX74AA AX74AA instead of MX77AA MX77AA, the load name prefix in field LOAD changes from CRI to XRI. For example, CRI08xx (for MX77) changes to XRI08XX (for AX74AA). The following example shows sample datafill for table RCCINV when the RCC2 is datafilled for the NTAX74AA CAP.

**Enhanced ESA (Lines and Trunks)** (continued)

**MAP display example for table RCCINV datafilled for NTAX74AA CAP**

```

Table: RCCINV
RCCNAME FRTRYPE FRNO SHPOS FLOOR ROW FRPOS EQPEC LOAD

CARY RCC2 0 CRSC 0 05 0 C 0 MX85AA XRI08xx

EXECTAB CONTMARK

(POTS POTSEX)(KEYSET KSETEX)(ABTRK DTCEX)(RMM_TERM RSMEX)(ESALINES ESAEX)
$

CSPM CSLNKTAB CONTMARK

LTC 1 (0) (1) (2) (3) (4) (5) (6) (7) $

ESA INTRASW OPTCARD CMRLOAD CONTMARK

Y Y (UTR6)(MSG6X69)(CMR18 CMRAG03) (ISP16) $

TONESET [PROCPEC] [E2LOAD]

NORTHAM [AX74AA AX74AA] [AX74xxxx]

```

**Datafilling table ESAPXLA**

ESA Trunk Translations tables support RSC-S line-to-trunk, trunk-to-trunk, and trunk-to-line call processing during ESA. Table ESAPXLA contains special prefix translation data used for POTS and IBN customers.

During regular RCC2 or RLCM operation, this table is not used and translations are performed in the CC. If, however, communication with the host is lost and the RCC2 or RLCM enters ESA, this table is used in the prefix translations.

The following table shows the datafill specific to Enhanced ESA (Lines and Trunks) for table ESAPXLA. Only those fields that apply directly to

## Enhanced ESA (Lines and Trunks) (continued)

Enhanced ESA (Lines and Trunks) are shown. Refer to the *Translations Guide* for a description of the other fields.

**Datafilling table ESAPXLA for RSC-S Enhanced ESA (Lines and Trunks) (Sheet 1 of 3)**

| Field                                                                                                   | Subfield or refinement | Entry                                  | Explanation and action                                                                                                                                                                                                                                  |
|---------------------------------------------------------------------------------------------------------|------------------------|----------------------------------------|---------------------------------------------------------------------------------------------------------------------------------------------------------------------------------------------------------------------------------------------------------|
| PXLAKEY                                                                                                 |                        | alphanumeric                           | Prefix translator key. Identifies a set of prefix digits on a certain site for a particular set of customers. Subfields: XLANAME, NODE, and PREFIX.                                                                                                     |
|                                                                                                         | XLANAME                | alphanumeric<br>(8 characters maximum) | Prefix translator name. If this translation is to be performed for any POTS line on the remote, enter ESAPOTS. If it is to be performed for a particular IBN customer group, enter any name and relate this name to a customer group in table CUSTHEAD. |
|                                                                                                         | NODE                   | alphanumeric                           | Node. The Remote Line Concentrating Module (RLCM), remote cluster controller (RCC), RCC2, or remote digital line module (RDLM) associated with the translator identified by XLANAME. Subfields: PMTYPE, LCMNO, SITE, and RCCNO.                         |
|                                                                                                         | PMTYPE                 | RCC2                                   | Peripheral module type. Identifies the peripheral node as either an RLCM, an RCC, an RCC2, or an RDLM. Enter RCC2.                                                                                                                                      |
|                                                                                                         | LCMNO                  |                                        | LCM number. Not applicable.                                                                                                                                                                                                                             |
|                                                                                                         | SITE                   | alphanumeric                           | Site. Enter the RCC2 location name.                                                                                                                                                                                                                     |
|                                                                                                         | RCCNO                  | numeric                                | RCC number. Enter the RCC2 PM number.                                                                                                                                                                                                                   |
|                                                                                                         | PREFIX                 | 0-63                                   | Prefix digits. Enter the 1- to 15-digit prefix with which the translation is to be associated.                                                                                                                                                          |
| RESULT                                                                                                  |                        | alphanumeric                           | Translation result. This field defines the action to be taken when the previously defined prefix digits are dialed on the remote. Subfield: SEL and entries contingent on the value entered for SEL.                                                    |
| <b>Note:</b> Routes for the R and D selectors must be in table ESARTE before the selectors can be used. |                        |                                        |                                                                                                                                                                                                                                                         |

**Enhanced ESA (Lines and Trunks)** (continued)

Datafilling table ESAPXLA for RSC-S Enhanced ESA (Lines and Trunks) (Sheet 2 of 3)

| Field                                                                                                   | Subfield or refinement | Entry               | Explanation and action                                                                                                                                                                                                                                                                                                                |
|---------------------------------------------------------------------------------------------------------|------------------------|---------------------|---------------------------------------------------------------------------------------------------------------------------------------------------------------------------------------------------------------------------------------------------------------------------------------------------------------------------------------|
|                                                                                                         | SEL                    | L, H, A, R, D, or T | Selector. Enter the selector multiple with the subfields L for line equipment numbe (LEN), H for hunt group (HTGRP), A for alternate translator (XLANAME), R for route (RR) with standard translations, D for routing with direct translations, T for treatment (TRMT) and datafill the subfields,                                    |
|                                                                                                         | L                      | see subfields       | If selector is L then enter subfields; terminating LEN, ambiguous code (AMBIG) (Y or N), and the ring code (RNCD) (0 to 7).                                                                                                                                                                                                           |
|                                                                                                         | H                      | see subfields       | If selector H enter subfields; hunt group (HTGRP) number from table HUNTGRP, sequence number (SEQNO) from table HUNTMEM and specify if the prefix digit is ambiguous (AMBIG) code (Y or N).                                                                                                                                           |
|                                                                                                         | A                      | see subfields       | If selector is A then enter subfields: multiple with an alternate translator name, and specify if a second dial tone (Y or N) is desired. Default alternate translators are: <ul style="list-style-type: none"> <li>• NPXLA—no prefix translations</li> <li>• ESAPOTS—standard translations</li> <li>• ESATRMT—retranslate</li> </ul> |
|                                                                                                         | R                      | see subfields       | If selector is R then enter subfields; multiple with the route number (RR) from table ESARTE, for standard trunking translations, number of digits (NUMDIG) to outpulse to outpulse and specify if prefix is AMBIG (Y or N).                                                                                                          |
| <b>Note:</b> Routes for the R and D selectors must be in table ESARTE before the selectors can be used. |                        |                     |                                                                                                                                                                                                                                                                                                                                       |



**Enhanced ESA (Lines and Trunks)** (continued)**Datafilling table ESAPXLA for RSC-S Enhanced ESA (Lines and Trunks) (Sheet 3 of 3)**

| Field | Subfield or refinement | Entry         | Explanation and action                                                                                                                                                                                                                                                                                                                   |
|-------|------------------------|---------------|------------------------------------------------------------------------------------------------------------------------------------------------------------------------------------------------------------------------------------------------------------------------------------------------------------------------------------------|
|       | D                      | see subfields | If selector is D then enter subfields; multiple with the route number (RR) from table ESARTE, for direct trunking translations, number of digits (NUMDIG) to outpulse and specify if a second dial tone (Y or N) is desired.                                                                                                             |
|       | T                      | see subfields | If selector is T enter special treatments to be applied to the call. Treatments are: <ul style="list-style-type: none"> <li>• REORDER—a fast busy tone</li> <li>• SRPXLA—strip the prefix digit and translate dialed digits</li> <li>• SRPDXLA—strip the prefix digit, provide a second dial tone and translate dialed digits</li> </ul> |

**Note:** Routes for the R and D selectors must be in table ESARTE before the selectors can be used.

**Datafill example for table ESAXPLA**

The following example shows sample datafill for table ESAXPLA.

**MAP display example for table ESAXPLA**

| Table: ESAPXLA |     |      |        |     |   |        |        |    |      |           |
|----------------|-----|------|--------|-----|---|--------|--------|----|------|-----------|
|                |     |      | PXLKEY |     |   |        | RESULT |    |      |           |
| -----          |     |      |        |     |   |        |        |    |      |           |
| ESAPOTS        | RCC | REM1 | 0      | 411 | L | REM100 | 0      | 00 | 02   | Y 1       |
| IBN1           | RCC | REM1 | 0      | 4   |   |        |        |    |      | T REORDER |
| IBN1           | RCC | REM1 | 0      | 6   |   |        |        |    |      | T SRPXLA  |
| IBN1           | RCC | REM1 | 0      | 9   |   |        |        |    |      | T SRPDXLA |
| IBN1           | RCC | REM1 | 0      | 7   | H |        |        |    | 5 7  | Y         |
| IBN2           | RCC | REM1 | 0      | 0   | A |        |        |    |      | ESATRMT Y |
| ESAPOTS        | RCC | REM1 | 0      | 5   | R |        |        |    | 21 7 | Y         |
| ESAPOTS        | RCC | REM1 | 0      | 8   | D |        |        |    | 10 4 | N         |

**Datafilling table CUSTHEAD (IBN only)**

The Customer Header (CUSTHEAD) table links a customer group to the prefix translation table name identified in table ESAPXLA.

For IBN lines, it is necessary to link the information in the ESAPXLA prefix tables to a particular customer group. The option ESAPXLA is used to specify the prefix translator name associated with the customer group.

## Enhanced ESA (Lines and Trunks) (continued)

With ESA, datafill fields OPTION and XLANAME of table CUSTHEAD. If the OPTION field does not have the ESAPXLA option set, no prefix translation for that customer group is provided.

The following table shows the datafill specific to Enhanced ESA (Lines and Trunks) for table CUSTHEAD. Only those fields that apply directly to Enhanced ESA (Lines and Trunks) are shown. Refer to the *Translations Guide* for a description of the other fields.

### Datafilling table CUSTHEAD

| Field   | Subfield or refinement | Entry           | Explanation and action                                                                              |
|---------|------------------------|-----------------|-----------------------------------------------------------------------------------------------------|
| OPTIONS |                        | ESAPXLA         | Option. Enter the option ESAPXLA.                                                                   |
| XLANAME |                        | character (1-8) | Prefix translator name. Enter 1 to 8 characters assigned to the prefix translator in table ESAPXLA. |

### Datafill example for table CUSTHEAD (IBN only)

The following example shows sample datafill for table CUSTHEAD.

### MAP display example for table CUSTHEAD

```

Table: CUSTHEAD

CUSTNAME CUSTXLA DGCOLNM IDIGCOL

POTSDATA POTSXLA POTS NIL
 (VACTRMT 0) (EXTNCOS 0) $

```

### Datafilling table TRKGRP

Table TRKGRP lists the characteristics of each trunk group. The field values are unchanged for ESA trunking.

Refer to the *Translations Guide* for a description of the field entries and value ranges for this table.

### Datafilling table ISTRKGRP

Table ISTRKGRP controls the dynamic nature of the trunks located on an RCC2. An entry in this table indicates that a trunk group has dynamic capability. This table contains the following information: the name or CLI

---

**Enhanced ESA (Lines and Trunks)** (continued)

---

of the trunk group, the site of the RCC2, and the RCC2 to which the trunk group is restricted. The field values are unchanged for ESA trunking.

Refer to the *Translations Guide* for a description of the field entries and value ranges for this table.

**Datafilling table TRKSGRP**

Table TRKSGRP lists the supplementary information for each subgroup assigned to one of the trunk groups listed in table TRKGRP. The field values are unchanged for ESA trunking.

Refer to the *Translations Guide* for a description of the field entries and value ranges for this table.

**Datafilling table TRKMEM**

Table TRKMEM contains the address of the actual trunk member. Each RCC2 trunk member has associated terminal data. If the information in the trunk tables indicates that the RCC2 ESA can support a unique trunk, ESA-specific data is collected and sent to the XPM. Field values are unchanged for ESA trunking.

Refer to the *Translations Guide* for a description of the field entries and value ranges for this table.

**Datafilling table ESARTE**

Table ESARTE identifies trunks to which a call may be routed during ESA. Table ESARTE format is similar to tables OFRT and IBNRTE. There is a maximum of 255 unique routes for each RCC2. One selector is supported.

Refer to the *Translations Guide* for a description of the field entries and value ranges for this table.

**Datafilling table ESAHNPA**

Table ESAHNPA associates the subscriber with one of the trunks referenced in table ESARTE. Prefix trunk entries for each customer group on each RCC2 are provided. Prefix digits identified in table ESAHNPA represent regular access codes to ESA trunk routes. A maximum of 32 access codes are available to POTS subscribers. A maximum of 16 access codes are available for each IBN customer group.

The following table shows the datafill specific to Enhanced ESA (Lines and Trunks) for table ESAHNPA. Only those fields that apply directly to

**Enhanced ESA (Lines and Trunks)** (continued)

Enhanced ESA (Lines and Trunks) are shown. Refer to the *Translations Guide* for a description of the other fields.

**Datafilling table ESAHNPA for RSC Enhanced ESA (Lines and Trunks) (Sheet 1 of 2)**

| Field                                                                                                                                                                                                                                                                                                                                                       | Subfield or refinement | Entry                       | Explanation and action                                                                                                                                                                                                                                                                       |
|-------------------------------------------------------------------------------------------------------------------------------------------------------------------------------------------------------------------------------------------------------------------------------------------------------------------------------------------------------------|------------------------|-----------------------------|----------------------------------------------------------------------------------------------------------------------------------------------------------------------------------------------------------------------------------------------------------------------------------------------|
| HNPAKEY                                                                                                                                                                                                                                                                                                                                                     |                        | alphanumeric                | ESAHNPA key. This key identifies a set of prefix digits on a certain site for a particular set of customers. Subfields: XLANAME, NODE, and PREFIX.                                                                                                                                           |
|                                                                                                                                                                                                                                                                                                                                                             | XLANAME                | alphanumeric                | Prefix translator name. If this translation is to be performed for any POTS line on the remote, enter ESAPOTS. If this translation is to be performed for a particular IBN customer group, enter any name up to eight characters and relate this name to a customer group in table CUSTHEAD. |
|                                                                                                                                                                                                                                                                                                                                                             | NODE                   | alphanumeric                | Node. This field is the RCLM or RCC2 node associated with the translator identified by XLANAME. Subfields: PMTYPE, SITE, and RCCNO.                                                                                                                                                          |
|                                                                                                                                                                                                                                                                                                                                                             | PMTYPE                 | RCC2                        | Identifies the PM as an RCC2. SITE and RCCNO must be datafilled. Enter RCC2.                                                                                                                                                                                                                 |
|                                                                                                                                                                                                                                                                                                                                                             | SITE                   | alphanumeric                | Enter the name assigned to the location of the RCC2.                                                                                                                                                                                                                                         |
|                                                                                                                                                                                                                                                                                                                                                             | RCC2NO                 | alphanumeric                | Enter the number assigned to the RCC2.                                                                                                                                                                                                                                                       |
|                                                                                                                                                                                                                                                                                                                                                             | PREFIX                 | numeric (15 digits maximum) | Prefix digits. Enter the prefix associated with the translation.                                                                                                                                                                                                                             |
| RESULT                                                                                                                                                                                                                                                                                                                                                      |                        | alphanumeric                | Translation result. This field defines the action to be taken when the previously defined prefix digits are dialed on the remote. Subfields: SEL, RR, NUMDIG and AMBIG.                                                                                                                      |
|                                                                                                                                                                                                                                                                                                                                                             | SEL                    | R                           | Selector. If the prefix digits entered in the PREFIX field specify a standard route, enter R and complete RR, NUMDIG, and AMBIG.                                                                                                                                                             |
| <p><b>Note:</b> For an AMBIG selection, digits 123 are considered ambiguous if another acceptable number was 12356. If N is entered, the switching process begins immediately after those prefix digits are dialed. If Y is entered, the remote waits for further digits. If none are entered during a given time period, the switching process begins.</p> |                        |                             |                                                                                                                                                                                                                                                                                              |

**Enhanced ESA (Lines and Trunks) (end)****Datafilling table ESAHNPA for RSC Enhanced ESA (Lines and Trunks) (Sheet 2 of 2)**

| Field                 | Subfield or refinement | Entry  | Explanation and action                                                                                                                           |
|-----------------------|------------------------|--------|--------------------------------------------------------------------------------------------------------------------------------------------------|
| RESULT<br>(continued) | RR                     | 0-255  | Route reference index. Specify the index of the route described in ESARTE where translation is to proceed.                                       |
|                       | NUMDIG                 | 0-15   | Collect digits. Specify the number of digits to collect before outpulsing.                                                                       |
|                       | AMBIG                  | N or Y | Ambiguous. If the prefix digits are completely unique, enter N. If the same digits may be dialed as the first digits of another number, enter Y. |

**Note:** For an AMBIG selection, digits 123 are considered ambiguous if another acceptable number was 12356. If N is entered, the switching process begins immediately after those prefix digits are dialed. If Y is entered, the remote waits for further digits. If none are entered during a given time period, the switching process begins.

**Datafill example for table ESAHNPA**

The following example shows sample datafill for table ESAHNPA.

**MAP display example for table ESAHNPA**

|                |      |      |   |     |        |   |   |   |  |
|----------------|------|------|---|-----|--------|---|---|---|--|
| Table: ESAHNPA |      |      |   |     |        |   |   |   |  |
| HNPAKEY        |      |      |   |     | RESULT |   |   |   |  |
| -----          |      |      |   |     |        |   |   |   |  |
| ESAPOTS        | RCC2 | CARY | 0 | 321 | R      | 1 | 7 | N |  |

**Translation verification tools**

To verify the translations that occur during ESA, ESATRAVER allows operating company personnel to perform a translation verification (TRAVER) on ESA-specific translations.

**SERVORD**

Enhanced ESA (Lines and Trunks) does not use SERVORD.

## Enhanced ESA for ISDN (Lines Only)

---

### Functional group

BAS00012

### Feature package

NTXQ12AA RSC Enhanced ESA (Lines Only)

### Release applicability

BCS34 and up

### Prerequisites

To operate, Enhanced ESA for ISDN (Lines Only) requires the following feature packages:

- NTX000AA Bilge
- NTX001AA Common Basic
- NTX145AA Remote Switching Center
- NTX149AA RSC ESA Operation—Lines

*Note:* Prerequisite packages are identical for packages NTXN82AB and NTXQ12AA, except for packages NTX149AA and NTX149AB. NTX149AA is a prerequisite package for NTXQ12AA. NTX149AB is a prerequisite package for NTXN82AB.

- NTX149AB RSC ESA Operation—Lines and Trunks

*Note:* Prerequisite packages are identical for packages NTXN82AB and NTXQ12AA, except for packages NTX149AA and NTX149AB. NTX149AA is a prerequisite package for NTXQ12AA. NTX149AB is a prerequisite package for NTXN82AB.

- NTX270AA New Peripheral Maintenance Package
- NTX901AA Local Features I

### Description

Call survival of supported calls over ESA warm entry and exit is expanded to include intraswitched and interswitched calls associated with the primary directory number key of BRA ISDN sets. Such calls on primary members or secondary members of multiple appearance directory numbers (MADN) are preserved during ESA warm entry and exit. Electronic key telephone service (EKTS) ISDN is also preserved during ESA warm entry and exit.

---

## Enhanced ESA for ISDN (Lines Only) (continued)

---

Terminating basic rate access (BRA) ISDN calls on secondary members of MADNs associated with the primary directory number key are preserved during ESA warm entry even though they cannot be made during ESA. These calls are also preserved during ESA warm exit if the calling party does not hang up during ESA.

The following calls are not supported:

- ISDN network switched (applicable for entry only)
- intraswitched and interswitched calls on secondary directory number keys of BRA ISDN sets

Packet switching is supported as follows:

- intraswitched and interswitched connections survive ESA warm entry and exit
- packet switching connected to the RCC2's central side (C-side) is re-established during ESA warm exit when the links are restored

### Operation

Static data is loaded from central control (CC) to the RCC2. While loading static data, the RCC2 is informed of the enhanced ESA ISDN package's existence. If enhanced ESA for ISDN does not exist, all ISDN calls are dropped. Upon entering ESA, the RCC2 begins supervising all intraswitched and interswitched calls that are supported in ESA. During ESA, calls are processed within the RCC2 without supervision from CC.

CC must resume supervision of all call processing in order to resume normal call processing. To enable CC to know which calls to set up, the RCC2 collects data concerning active supported calls and forwards the information to CC. ISDN call information is now included in the data sent to CC.

### Translations table flow

The Enhanced ESA for ISDN (Lines Only) translations tables are described in the following list:

- Table CUSTHEAD links a customer group to the prefix translation table name as identified in table ESAPXLA. Field XLANAME of table CUSTHEAD corresponds to the prefix translator name assigned in field XLANAME from table ESAPXLA to access prefix translation data.
- Table ESAPXLA is used to support line-to-trunk, trunk-to-trunk, and trunk-to-line call processing in the Remote Switching Center-SONET (Synchronous Optical Network) during ESA. Table ESAPXLA contains special prefix translation data used for plain old telephone service (POTS)

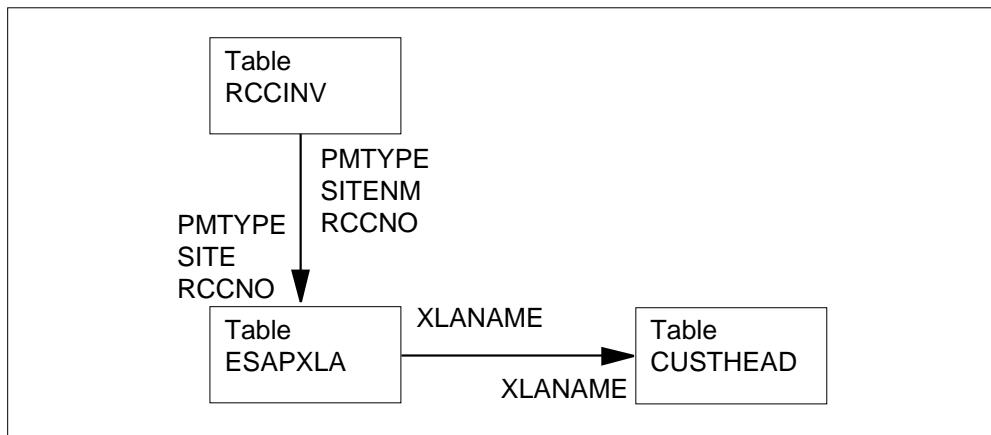
## Enhanced ESA for ISDN (Lines Only) (continued)

and Integrated Business Network (IBN) customers. Fields PMTYPE, SITE, and RCCNO in table ESAPXLA correspond to the PMTYPE, SITENM, and RCCNO tuple from table RCCINV to access inventory data (except peripheral-side [P-side] link assignments) for the identified RCC2.

- Table RCCINV maintains a list of RCC2s that are datafilled in the Digital Multiplex System (DMS) system and contains inventory data (except P-side link assignments) for the RCC2s. The table information identifies where the RCC2 is located, the load and exec lineups required, and the network link connections. C-side DS-1 assignments for the RCC2 are datafilled in table RCCINV. Intraswitching is datafilled in table RCCINV.

The Enhanced ESA for ISDN (Lines Only) translation process is shown in the flowchart that follows.

**Table flow for Enhanced ESA for ISDN (Lines Only)**



### Limitations and restrictions

The following limitations and restrictions apply to Enhanced ESA for ISDN (Lines Only):

- Dial tone is usually restored within seconds. The actual amount of dial tone delay depends on different factors such as
  - type of DMS-100 switch (NT40 or Supernode)
  - call mix
  - occupancy of CC processing unit
  - link configuration between RCC2, host XPM-based peripheral module (XPM), and CC
  - distance of RCC2 from host XPM
- Feature activation is not supported on calls surviving warm entry and exit



---

## Enhanced ESA for ISDN (Lines Only) (continued)

---

- Primary rate interface calls are not supported
- Generic services framework calls are not supported

### Interactions

Enhanced ESA for ISDN (Lines Only) has no functionality interactions.

### Activation/deactivation by the end user

Enhanced ESA for ISDN (Lines Only) requires no activation or deactivation by the end user.

### Billing

Enhanced ESA for ISDN (Lines Only) does not affect billing.

### Station Message Detail Recording

Enhanced ESA for ISDN (Lines Only) does not affect Station Message Detail Recording.

### Datafilling office parameters

The following table shows the office parameters used by Enhanced ESA for ISDN (Lines Only). For more information about office parameters, refer to *Office Parameters Reference Manual*.

#### Office parameters used by Enhanced ESA for ISDN (Lines Only)

| Table name | Office parameter    | Explanation and action                                                                                |
|------------|---------------------|-------------------------------------------------------------------------------------------------------|
| OFCENG     | RSC_ESA_NOTIFY_TONE | This parameter defines whether the subscriber will hear a tone burst when ESA is entered. Default: Y. |
|            | RSC_XPMESAEXIT      | This parameter delays ESA exit to prevent bouncing links. Default: 6.                                 |
|            | RSC_ESASDUPD_BOOL   | This parameter specifies whether nightly updates of static data should be performed. Default: YES.    |
|            | RSC_ESASDUPD_HOUR   | This parameter specifies the starting time of the daily update of ESA static data. Default: 2.        |

## Enhanced ESA for ISDN (Lines Only) (continued)

---

### Datavill sequence

The following table lists the tables that require datavill to implement Enhanced ESA for ISDN (Lines Only). The tables are listed in the order in which they are to be datavilled.

#### Datavill tables required for Enhanced ESA for ISDN (Lines Only)

| Table    | Purpose of table                                                                                                                                                                                                                 |
|----------|----------------------------------------------------------------------------------------------------------------------------------------------------------------------------------------------------------------------------------|
| OFCENG   | Office Engineering. This table contains data on engineering parameters for the office. Refer to "Datavilling office parameters" for how Enhanced ESA for ISDN (Lines Only) affects office parameters.                            |
| RCCINV   | Remote Cluster Controller Inventory. This table contains the inventory data, except the P-side link assignments, for the remote cluster controller (RCC).                                                                        |
| ESAPXLA  | Emergency Stand-Alone Prefix Translation. This table supports RSC-S line-to-trunk, trunk-to-trunk, and trunk-to-line call processing during ESA and contains ESAPXLA special prefix translation data for POTS and IBN customers. |
| CUSTHEAD | Customer Head Group. This table links a customer group to the prefix translation table name as identified in table ESAPXLA.                                                                                                      |

### Datavilling table RCCINV

The following table shows the datavill specific to Enhanced ESA for ISDN (Lines Only) for table RCCINV. Only those fields that apply directly to

---

## Enhanced ESA for ISDN (Lines Only) (continued)

---

Enhanced ESA for ISDN (Lines Only) are shown. Refer to the *Translations Guide* for a description of the other fields.

### Datafilling table RCCINV

| Field                                                                                                                                                                                                                                                                                                                                                                                                                                     | Subfield or refinement | Entry         | Explanation and action                                                                                                                                                                                                                                                                                                 |
|-------------------------------------------------------------------------------------------------------------------------------------------------------------------------------------------------------------------------------------------------------------------------------------------------------------------------------------------------------------------------------------------------------------------------------------------|------------------------|---------------|------------------------------------------------------------------------------------------------------------------------------------------------------------------------------------------------------------------------------------------------------------------------------------------------------------------------|
| EXECTAB                                                                                                                                                                                                                                                                                                                                                                                                                                   |                        | see subfields | Executive table. Subfields: TRMTYPE, EXEC, and CONTMARK. More than one combination (8 maximum) can be used for a given PM.                                                                                                                                                                                             |
|                                                                                                                                                                                                                                                                                                                                                                                                                                           | TRMTYPE                | ESALINES      | Terminal type. Enter the PM terminal types used. Entry values: POTS (regular lines), KEYSET (IBN/data lines), RMM_TERM (remote maintenance module [RMM] terminals), ABTRK (regular trunks), and ESALINES (ESA lines).<br><br>See Note 1 for information about changes to fields with multiple entries.                 |
|                                                                                                                                                                                                                                                                                                                                                                                                                                           | EXEC                   | ESAEX         | Executive programs. Enter the set of executive programs required for the PM specified in TRMTYPE. Entry values: POTSEX (TRMTYPE is POTS), KSETEX (TRMTYPE is KEYSET), RSMEX (TRMTYPE is RMM_TERM) DTCEX or FXODCM, depending on the type of trunking (TRMTYPE is ABTRK), and ESAEX (TRMTYPE is ESALINES). Enter ESAEX. |
| ESA                                                                                                                                                                                                                                                                                                                                                                                                                                       |                        | Y or N        | Emergency stand alone. Entry values: Y (the RSC-S has the ESA option) and N (the RSC-S does not have the ESA option). Enter Y.                                                                                                                                                                                         |
| <p><b>Note 1:</b> Changes to fields with multiple entries should be made in the PROMPT mode only. In nonprompt mode it is possible to leave out existing entries.</p> <p><b>Note 2:</b> Enter the continuation mark (+) in fields with multiple possible entries when more data is specified on the next line or more records will be entered. Enter the end mark (\$) in fields with multiple possible entries after the last entry.</p> |                        |               |                                                                                                                                                                                                                                                                                                                        |

### Datafill example for table RCCINV

The following examples show sample datafills for table RCCINV for both an RCC2 provisioned with the NTMX77AA UP and an RCC2 provisioned with the optional NTAX74AA CAP, respectively.

**Enhanced ESA for ISDN (Lines Only)** (continued)

**MAP display example for table RCCINV datafilled for NTMX77AA UP**

```

Table: RCCINV
RCCNAME FRTYPE FRNO SHPOS FLOOR ROW FRPOS EQPEC LOAD

CARY RCC2 0
 1101 CRSC 0 5 0 C 0 MX85AA CRI08xx
EXECTAB
(POTS POTSEX) (KEYSET KSETEX) (RMM_TERM RSMEX) (ESALINES ESAEX) $
CSPM CSLNKTAB

LTC 1 (0) (1) (2) (3) (4) (5) (6) (7)
ESA INTRASW OPTCARD CMRLOAD CONTMARK
Y Y (UTR6) (NT7X05AA 7) (MSG6X69) (CMR5 CMRAG03) (ISP16) $
TONESET PROCPEC E2LOAD EXTINFO
NORTHAM MX77AA MX77AA MX77xxxx CEXT 0 4 0 E 15 MX86AA L

```

**Note 1:** xx in field LOAD and xxxx in field E2LOAD represent alphanumeric entries, for example B1 and XE01, respectively.

**Note 2:** If the shelf is equipped with a processor other than NTMX77 or the optional NTAX74, field E2LOAD is automatically datafilled with value NILLOAD.

**Note 3:** When field PROCPEC is datafilled with AX74AA AX74AA instead of MX77AA MX77AA, the load name prefix in field LOAD changes from CRI to XRI. For example, CRI08xx (for MX77) changes to XRI08XX (for AX74AA). The following example shows sample datafill for table RCCINV when the RCC2 is datafilled for the NTAX74AA CAP.

## Enhanced ESA for ISDN (Lines Only) (continued)

### MAP display example for table RCCINV datafilled for NTAX74AA CAP

```

Table: RCCINV
RCCNAME FRTYPE FRNO SHPOS FLOOR ROW FRPOS EQPEC LOAD

CARY RCC2 0
 1101 CRSC 0 5 0 C 0 MX85AA XRI08xx
EXECTAB
(POTS POTSEX) (KEYSET KSETEX) (RMM_TERM RSMEX) (ESALINES ESAEX) $
CSPM CSLNKTAB
LTC 1 (0) (1) (2) (3) (4) (5) (6) (7) $
ESA INTRASW OPTCARD CMRLOAD CONTMARK
Y Y (UTR6) (MSG6X69) (CMR5 CMRAG03) (ISP16) $
TONESET PROCPEC E2LOAD EXTINFO
NORTHAM AX74AA AX74AA AX74xxxxx CEXT 0 4 0 E 15 MX86AA L

```

### Datafilling table ESAPXLA

The following table shows the datafill specific to Enhanced ESA for ISDN (Lines Only) for table ESAPXLA. Only those fields that apply directly to Enhanced ESA for ISDN (Lines Only) are shown. Refer to the *Translations Guide* for a description of the other fields.

#### Datafilling table ESAPXLA (Sheet 1 of 3)

| Field   | Subfield or refinement | Entry                               | Explanation and action                                                                                                                                                                                                                                                         |
|---------|------------------------|-------------------------------------|--------------------------------------------------------------------------------------------------------------------------------------------------------------------------------------------------------------------------------------------------------------------------------|
| PXLAKEY |                        | see subfields                       | Prefix translator key. This key identifies a set of prefix digits on a certain site for a particular set of customers. Subfields: XLANAME, NODE, and PREFIX.                                                                                                                   |
|         | XLANAME                | alphanumeric (8 characters maximum) | Prefix translator name. If this translation is to be performed for any POTS line on the remote, enter ESAPOTS. If it is to be performed for a particular IBN customer group, enter any name (8 characters maximum) and relate this name to a customer group in table CUSTHEAD. |

**Enhanced ESA for ISDN (Lines Only)** (continued)

## Datafilling table ESAPXLA (Sheet 2 of 3)

| Field  | Subfield or refinement | Entry             | Explanation and action                                                                                                                                                                                                                                    |
|--------|------------------------|-------------------|-----------------------------------------------------------------------------------------------------------------------------------------------------------------------------------------------------------------------------------------------------------|
|        | NODE                   | see subfields     | Node. The Remote Line Concentrating Module (RLCM) remote cluster controller (RCC), RCC2, or remote digital line module (RDLM) associated with the translator identified by XLANAME. Subfields: PMTYPE, LCMNO, SITE, and RCCNO. Entry value: alphanumeric. |
|        | PMTYPE                 | RCC2              | Peripheral module type. Identifies the peripheral node as either an RLCM, an RCC, an RCC2, or an RDLM.                                                                                                                                                    |
|        | SITE                   | alphanumeric      | Site. Enter the RCC2 location name.                                                                                                                                                                                                                       |
|        | RCCNO                  | 0-255             | RCC number. Enter the RCC2 PM number.                                                                                                                                                                                                                     |
|        | PREFIX                 | 0-9               | Prefix digits. Enter the 1- to 15-digit prefix with which the translation is to be associated.                                                                                                                                                            |
| RESULT |                        | see subfield      | Translation result. This field defines the action to be taken when the previously defined prefix digits are dialed on the remote. Subfield: SEL and entries contingent on the value entered for SEL. Entry value: alphanumeric.                           |
|        | SEL                    | L (see subfields) | Selector. If the entry in PREFIX specifies a line, enter L and complete subfields LEN, AMBIG, and RNGCD.                                                                                                                                                  |
|        | LEN                    | see subfields     | Line equipment number. This subfield defines the line where the call is to terminate. Subfields: SITE, FRAME, UNIT, LSG, and CIRCUIT. Entry value: alphanumeric.                                                                                          |
|        | SITE                   | alphanumeric      | Site. Enter the site name where the termination line is located. Since the remote is operating in ESA, there is no communication with the host. The site name must match the site name specified in subfield NODE.                                        |
|        | FRAME                  | 0-511             | Frame. Enter the frame number at this site that contains the line card for the termination line. For PMTYPE RCC2, communication is supported between all line concentrating modules (LCM) or DLMS attached to the RCC2.                                   |

**Enhanced ESA for ISDN (Lines Only)** (continued)**Datafilling table ESAPXLA (Sheet 3 of 3)**

| Field | Subfield or refinement | Entry  | Explanation and action                                                                                                                     |
|-------|------------------------|--------|--------------------------------------------------------------------------------------------------------------------------------------------|
|       | UNIT                   | 0-1    | Unit. Enter the unit number of the LCM, RLCM, digital line module (DLM), or RDLM to which the line is assigned.                            |
|       | LSG                    | 0-19   | Line subgroup. Enter the number of the line subgroup of the LCM, RLCM, DLM, or RDLM unit where the line card for that line is assigned.    |
|       | CIRCUIT                | 0-31   | Circuit. Enter the line card circuit number of the line subgroup where the line card is assigned.                                          |
|       | AMBIG                  | Y or N | Ambiguous. Entry value: Y (if the same digits may be dialed as the first digits of another number), or N (if prefix digits are unique).    |
|       | RNGCD                  | 0-7    | Ring code. Enter the code for the type of ringing associated with the line specified in the LEN field. This is for lines on an LCM or DLM. |

**Datafill example for table ESAPXLA**

The following example shows sample datafill for table ESAPXLA.

**MAP display example for table ESAPXLA**

```

PXLKEY

ESAPOTS RCC2 CARY 0 411
IBN1 RCC2 CARY 0 6
IBN1 RCC2 CARY 0 9
ESATEST RCC2 CARY 0 611

RESULT

L CARY 00 0 00 02 Y 1
T SRPXLA
T SRPDXLA
L CARY 02 0 01 20 N 1

```

**Datafilling table CUSTHEAD**

The following table shows the datafill specific to Enhanced ESA for ISDN (Lines Only) for table CUSTHEAD. Only those fields that apply directly to

## Enhanced ESA for ISDN (Lines Only) (end)

Enhanced ESA for ISDN (Lines Only) are shown. Refer to the *Translations Guide* for a description of the other fields.

### Datafilling table CUSTHEAD

| Field   | Subfield or refinement | Entry           | Explanation and action                                                                                                         |
|---------|------------------------|-----------------|--------------------------------------------------------------------------------------------------------------------------------|
| OPTIONS |                        | ESAPXLA         | Option. This field lists options and associated subfields which are selectively assigned to the customer group. Enter ESAPXLA. |
|         | XLANAME                | character (1-8) | Prefix translator name. Enter the 1 to 8 characters assigned to the prefix translator table in field XLANAME of table ESAPXLA. |

### Datafill example for table CUSTHEAD

The following example shows sample datafill for table CUSTHEAD.

### MAP display example for table CUSTHEAD

```

CUSTNAME CUSTXLA DGCOLNM IDIGCOL
 OPTIONS

RESGRP RESSORT RES1 NIL
(VACTRMT 0) (EXTNCOS 0) (DISAFAC DISARAC) (VFGLA)$

BNRTRAF TRAFXLA TRAF NIL
 (VACTRMT 0) (EXTNCOS 0) (ACCT 4 N N)$
E911 POTSXLA NDGT NIL
 (VACTRMT 0) (EXTNOS 0) $

```

### Translation verification tools

Enhanced ESA for ISDN (Lines Only) does not use translation verification tools.

### SERVORD

Enhanced ESA for ISDN (Lines Only) does not use SERVORD.



---

## Enhanced ESA for ISDN (Lines and Trunks)

---

### Functional group

BAS00012

### Feature package

Refer to "Enhanced ESA (Lines and Trunks)" in the "Remote Switching Center-SONET" section of this document. RSC Enhanced ESA (Lines and Trunks) uses the following feature packages:

- NTXN82AB RSC Enhanced ESA (Lines and Trunks)
- NTXQ12AA RSC Enhanced ESA (Lines)

### Release applicability

BCS34 and up

### Prerequisites

Enhanced ESA for ISDN (Lines and Trunks) requires the following feature packages:

- NTX000AA Bilge
- NTX001AA Common Basic
- NTX145AA Remote Switching Center
- NTX149AA RSC ESA Operation—Lines

*Note:* Prerequisite packages are identical for packages NTXN82AB and NTXQ12AA, except for packages NTX149AA and NTX149AB. NTX149AA is a prerequisite package for NTXQ12AA. NTX149AB is a prerequisite package for NTXN82AB.

- NTX149AB RSC ESA Operation—Lines and Trunks

*Note:* Prerequisite packages are identical for packages NTXN82AB and NTXQ12AA, except for packages NTX149AA and NTX149AB. NTX149AA is a prerequisite package for NTXQ12AA. NTX149AB is a prerequisite package for NTXN82AB.

- NTX270AA New Peripheral Maintenance Package
- NTX901AA Local Features I

### Description

Call survival of supported calls over ESA warm entry and exit is expanded to include intraswitched and interswitched calls associated with the primary

## Enhanced ESA for ISDN (Lines and Trunks) (continued)

---

directory number key of BRA ISDN sets. Such calls on primary members or secondary members of multiple appearance directory numbers (MADN) are preserved during ESA warm entry and exit. Electronic key telephone service (EKTS) ISDN is also preserved during ESA warm entry and exit.

Terminating basic rate access (BRA) ISDN calls on secondary members of MADNs associated with the primary directory number key are preserved during ESA warm entry even though they cannot be made during ESA. These calls are also preserved during ESA warm exit if the calling party does not hang up during ESA.

The following calls are not supported:

- ISDN network switched (applicable for entry only)
- intraswitched and interswitched calls on secondary directory number keys of BRA ISDN sets

Packet switching is supported as follows:

- intraswitched and interswitched connections survive ESA warm entry and exit
- packet switching connected to the RCC2's central side (C-side), is re-established during ESA warm exit when the links are restored

## Operation

Static data is loaded from central control (CC) to the RCC2. While loading static data, the RCC2 is informed of the existence of Enhanced ESA ISDN. If enhanced ESA for ISDN does not exist, all ISDN trunks calls are dropped. Upon entering ESA, the RCC2 begins supervising all intraswitched and interswitched calls that are supported in ESA. During ESA, calls are processed within the RCC2 without supervision from CC.

CC must resume supervision of all call processing in order to resume normal call processing. To enable CC to know which calls to set up, the RCC2 collects data concerning active supported calls and forwards the information to CC. ISDN call information is now included in the data sent to CC.

---

**Enhanced ESA for ISDN (Lines and Trunks)** (continued)

---

**Translations table flow**

The Enhanced ESA for ISDN (Lines and Trunks) translations tables are described in the following list:

- Table ESAHNPA contains prefix translation used for normal prefix translation for trunks. The HNPAAKEY tuple is indexed by the RTEKEY tuple in table ESARTE to access the route entry.
- Table ESARTE identifies trunks that a call may be routed to during ESA. Field RTEKEY indexes into field HNPAAKEY (table ESAHNPA) or field PXLAAKEY (table ESAPXLA) to access the route entry.
- Table TRKMEM lists the data associated with each trunk assigned to one of the trunk groups and subgroups specified in tables TRKGRP and TRKSGRP. This table identifies the circuits associated with static trunks, dynamic trunks, and the test equipment used to test lines and trunks. Field CLLI in table TRKMEM corresponds to the CLLI code for the trunk group.
- Table TRKSGRP lists the supplementary information for each subgroup that is assigned to one of the trunk groups listed in table TRKGRP. Field CLLI in table TRKSGRP corresponds to the CLLI code for the trunk group.
- Table ISTRKGRP controls the dynamic nature of the trunks located on an RCC2. An entry in this table indicates that a trunk group has dynamic capability. Subfield SITE\_ID in table ISTRKGRP corresponds to the NAME tuple from table SITE to identify the equipment for the switching unit and for all remote locations that home on to it. Field ISTRKKEY in table ISTRKGRP corresponds to the CLLI tuple from table CLLI that identifies the trunk group that should be assigned dynamic capability.
- Table TRKGRP defines data for each trunk group associated with the switching unit. Field CLLI in table TRKGRP corresponds to the CLLI code for the trunk group.
- Table CUSTHEAD links a customer group to the prefix translation table name as identified in table ESAPXLA if the translation is performed for a particular Integrated Business Network (IBN) customer group. Field XLANAME table CUSTHEAD corresponds to the prefix translator name assigned in field XLANAME from table ESAPXLA to access prefix translation data.
- Table ESAPXLA identifies exceptions rather than normal prefix translation for ESA. Table ESAPXLA contains special prefix translation data used for plain old telephone service (POTS) and IBN customers. The PXLAAKEY tuple is indexed by the RTEKEY tuple in table ESARTE to access the route entry. The NODE tuple in table ESAPXLA correspond to

## Enhanced ESA for ISDN (Lines and Trunks) (continued)

---

the RCCNAME tuple from table RCCINV to access inventory data (except peripheral-side [P-side] link assignments) for the identified RCC2.

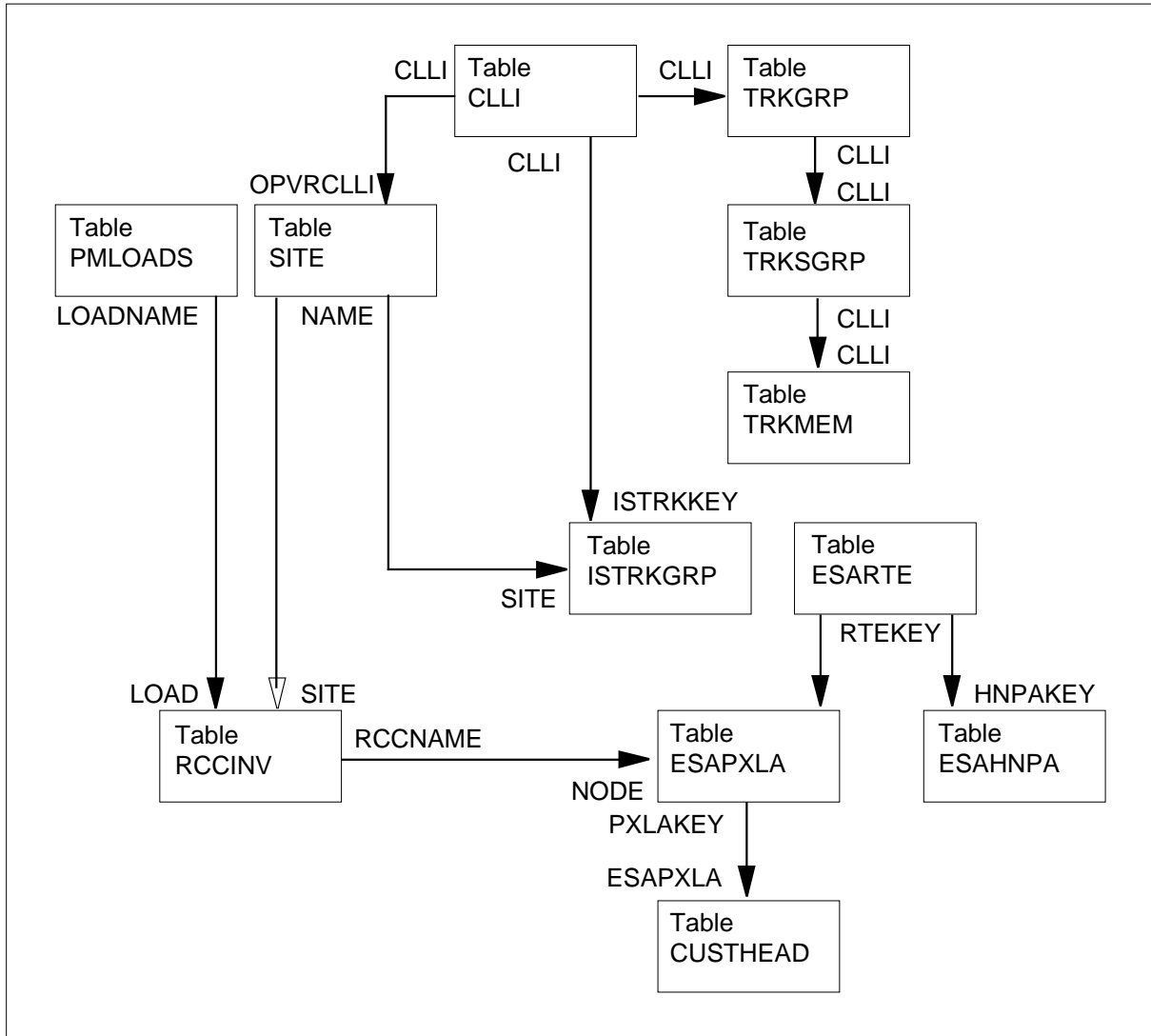
- Table RCCINV maintains a list of RCC2s that are datafilled in the DMS system and contains inventory data (except P-side link assignments) for the RCC2s. The table information identifies where the RCC2 is located, the load and exec lineups required, and the network link connections. C-side DS-1 assignments for the RCC2 are datafilled in table RCCINV. Intraswitching is datafilled in table RCCINV.

Load information for this table is datafilled in field LOAD and corresponds to the LOADNAME tuple from table PMLOADS. Also, the RCCNAME tuple in table RCCINV corresponds to the NODE tuple from table ESAPXLA. Field RCCNAME stores site information (originally entered in field NAME from table SITE), the peripheral module (PM) type, and PM number.

The Enhanced ESA for ISDN (Lines and Trunks) translation process is shown in the flowchart that follows.

**Enhanced ESA for ISDN (Lines and Trunks) (continued)**

**Table flow for Enhanced ESA for ISDN (Lines and Trunks)**



## **Enhanced ESA for ISDN (Lines and Trunks)** (continued)

---

### **Limitations and restrictions**

The following limitations and restrictions apply to Enhanced ESA for ISDN (Lines and Trunks):

- Dial tone is usually restored within seconds. The actual amount of dial tone delay depends on different factors such as
  - type of DMS-100 switch (NT40 or SuperNode)
  - call mix
  - occupancy of CC processing unit
  - link configuration between RCC2, host XPM-based peripheral module (XPM), and CC
  - distance of RCC2 from host XPM
- Feature activation is not supported on calls surviving warm entry and exit.
- Primary rate interface calls are not supported.
- Generic services framework calls are not supported.

### **Interactions**

Enhanced ESA for ISDN (Lines and Trunks) has no functionality interactions.

### **Activation/deactivation by the end user**

Enhanced ESA for ISDN (Lines and Trunks) requires no activation or deactivation by the end user.

### **Billing**

Enhanced ESA for ISDN (Lines and Trunks) does not affect billing.

### **Station Message Detail Recording**

Enhanced ESA for ISDN (Lines and Trunks) does not affect Station Message Detail Recording.

---

## Enhanced ESA for ISDN (Lines and Trunks) (continued)

---

### Datafilling office parameters

The following table shows the office parameters used by Enhanced ESA for ISDN (Lines and Trunks). For more information about office parameters, refer to *Office Parameters Reference Manual*.

#### Office parameters used by RSC-S Enhanced ESA for ISDN (Lines and Trunks)

| Table name | Parameter name      | Explanation and action                                                             |
|------------|---------------------|------------------------------------------------------------------------------------|
| OFCENG     | RSC_ESA_NOTIFY_TONE | Defines whether the subscriber hears a tone burst when ESA is entered. Default: Y. |
|            | RSC_XPMESAEXIT      | Delays ESA exit to prevent bouncing links. Default: 6.                             |
|            | RSC_ESASDUPD_BOOL   | Specifies whether nightly updates of static data should be performed. Default: Y.  |
|            | RSC_ESASDUPD_HOUR   | Specifies the starting time of the daily update of ESA static data. Default: 2.    |

### Datafill sequence

The following table lists the tables that require datafill to implement Enhanced ESA for ISDN (Lines and Trunks). The tables are listed in the order in which they are to be datafilled.

#### Datafill tables required for RSC-S Enhanced ESA for ISDN (Lines and Trunks) (Sheet 1 of 2)

| Table    | Purpose of table                                                                                                                                                                                                               |
|----------|--------------------------------------------------------------------------------------------------------------------------------------------------------------------------------------------------------------------------------|
| RCCINV   | Remote Cluster Controller Inventory. Contains RCC2 inventory data (except P-side inventory assignments). RCC2 C-side digital signal 1 (DS-1) assignments are datafilled in table RCCINV.                                       |
| ESAPXLA  | Emergency Stand-Alone Prefix Translations. Support RSC-S line-to-trunk, trunk-to-trunk, and trunk-to-line call processing during ESA. Table ESAPXLA contains special prefix translation data for POTS and IBN customer groups. |
| CUSTHEAD | Customer Header. Links a customer group to the prefix translation table name identified in table ESAPXLA.                                                                                                                      |
| TRKGRP   | Trunk Group. This table lists the characteristics of each trunk group.                                                                                                                                                         |
| ISTRKGRP | RCC Dynamic Trunk Groups. Controls the dynamic nature of RCC2 trunks. An entry in this table indicates that a trunk group has dynamic capability.                                                                              |
| TRKSGRP  | Trunk Subgroup. Lists supplementary information for each subgroup assigned to one of the trunk groups listed in table TRKGRP.                                                                                                  |

## Enhanced ESA for ISDN (Lines and Trunks) (continued)

### Datafill tables required for RSC-S Enhanced ESA for ISDN (Lines and Trunks) (Sheet 2 of 2)

| Table   | Purpose of table                                                                                                                           |
|---------|--------------------------------------------------------------------------------------------------------------------------------------------|
| TRKMEM  | Trunk Member. Contains the address of the actual trunk member. Each trunk member residing on an RCC2 has terminal data associated with it. |
| ESARTE  | Emergency Stand-Alone Route. Identifies trunks a call can route to during ESA.                                                             |
| ESAHNPA | ESA Home Numbering Plan Area. Allows a subscriber to select one of the trunks referenced in table ESARTE.                                  |

### Datafilling table RCCINV

The following table shows the datafill specific to Enhanced ESA for ISDN (Lines and Trunks) for table RCCINV. Only those fields that apply directly to Enhanced ESA for ISDN (Lines and Trunks) are shown. For a description of the other fields, refer to the *Translation Guide*.

#### Datafilling table RCCINV (Sheet 1 of 2)

| Field                                                                                                                                                                                                                                                                                                                                                                                                                                                                                                                                                                                                                                                                                                                                                                                                                                                                                                                                                                                                                                          | Subfield or refinement | Entry         | Explanation and action                                                                                                                                                                                           |
|------------------------------------------------------------------------------------------------------------------------------------------------------------------------------------------------------------------------------------------------------------------------------------------------------------------------------------------------------------------------------------------------------------------------------------------------------------------------------------------------------------------------------------------------------------------------------------------------------------------------------------------------------------------------------------------------------------------------------------------------------------------------------------------------------------------------------------------------------------------------------------------------------------------------------------------------------------------------------------------------------------------------------------------------|------------------------|---------------|------------------------------------------------------------------------------------------------------------------------------------------------------------------------------------------------------------------|
| EXECTAB                                                                                                                                                                                                                                                                                                                                                                                                                                                                                                                                                                                                                                                                                                                                                                                                                                                                                                                                                                                                                                        |                        | see subfields | Executive table. Subfields: TRMTYPE and EXEC. More than one combination (8 maximum) can be used for a given PM.                                                                                                  |
|                                                                                                                                                                                                                                                                                                                                                                                                                                                                                                                                                                                                                                                                                                                                                                                                                                                                                                                                                                                                                                                | TRMTYPE                | ESALINES      | Terminal type. Enter the PM terminals type. Entry values: POTS (regular lines), KEYSET (IBN/data lines), RMM_TERM (remote maintenance module [RMM] terminals), ABTRK (regular trunks), and ESALINES (ESA lines). |
| <p><b>Note 1:</b> Changes to fields with multiple entries should be made in the PROMPT mode only. In nonprompt mode it is possible to leave out existing entries.</p> <p><b>Note 2:</b> Enter the continuation mark (+) in fields with multiple possible entries when more data is specified on the next line or more records will be entered. Enter the end mark (\$) in fields with multiple possible entries after the last entry.</p> <p><b>Note 3:</b> When datafilling field C-side link table (CSLNKTAB), assure message links are not assigned to the same physical interface card. When the interface card supports two or more links, separate the message links by the number of links on the interface cards. This applies to all interface link types; DS-1, DS30, DS30A, or PCM-30. Table control will issue a warning if an attempt is made to assign message links on the same interface card. Assigning message links to the same interface card can cause an E1 outage (failure of all message links) if the card fails.</p> |                        |               |                                                                                                                                                                                                                  |



---

## Enhanced ESA for ISDN (Lines and Trunks) (continued)

---

### Datafilling table RCCINV (Sheet 2 of 2)

| Field                                                                                                                                                                                                                                                                                                                                                                                                                                                                                                                                                                                                                                                                                                                                                                                                                                                                                                                                                                                                                                          | Subfield or refinement | Entry | Explanation and action                                                                                                                                                                                                                                                                                               |
|------------------------------------------------------------------------------------------------------------------------------------------------------------------------------------------------------------------------------------------------------------------------------------------------------------------------------------------------------------------------------------------------------------------------------------------------------------------------------------------------------------------------------------------------------------------------------------------------------------------------------------------------------------------------------------------------------------------------------------------------------------------------------------------------------------------------------------------------------------------------------------------------------------------------------------------------------------------------------------------------------------------------------------------------|------------------------|-------|----------------------------------------------------------------------------------------------------------------------------------------------------------------------------------------------------------------------------------------------------------------------------------------------------------------------|
|                                                                                                                                                                                                                                                                                                                                                                                                                                                                                                                                                                                                                                                                                                                                                                                                                                                                                                                                                                                                                                                | EXEC                   | ESAEX | Executive programs. Enter the set of executive programs required for the PM specified in the TRMTYPE entry. Entry values: POTSEX (TRMTYPE is POTS), KSETEX (TRMTYPE is KEYSET), RSMEX (TRMTYPE is RMM_TERM), DTCEX or FXODCM, depending on the type of trunking (TRMTYPE is ABTRK), and ESAEX (TRMTYPE is ESALINES). |
| ESA                                                                                                                                                                                                                                                                                                                                                                                                                                                                                                                                                                                                                                                                                                                                                                                                                                                                                                                                                                                                                                            |                        | Y     | Emergency stand-alone. Entry values: Y (the Remote Switching Center-SONET [RSC-S] has the ESA option) and N (the RSC-S does not have the ESA option). Enter Y.                                                                                                                                                       |
| <p><b>Note 1:</b> Changes to fields with multiple entries should be made in the PROMPT mode only. In nonprompt mode it is possible to leave out existing entries.</p> <p><b>Note 2:</b> Enter the continuation mark (+) in fields with multiple possible entries when more data is specified on the next line or more records will be entered. Enter the end mark (\$) in fields with multiple possible entries after the last entry.</p> <p><b>Note 3:</b> When datafilling field C-side link table (CSLNKTAB), assure message links are not assigned to the same physical interface card. When the interface card supports two or more links, separate the message links by the number of links on the interface cards. This applies to all interface link types; DS-1, DS30, DS30A, or PCM-30. Table control will issue a warning if an attempt is made to assign message links on the same interface card. Assigning message links to the same interface card can cause an E1 outage (failure of all message links) if the card fails.</p> |                        |       |                                                                                                                                                                                                                                                                                                                      |

### Datafill example for table RCCINV

The following examples show sample datafills for table RCCINV for both an RCC2 provisioned with the NTMX77AA UP and an RCC2 provisioned with the optional NTAX74AA CAP, respectively.

**Enhanced ESA for ISDN (Lines and Trunks)** (continued)

**MAP display example for table RCCINV datafilled for NTMX77AA UP**

```

Table: RCCINV
RCCNAME FRTYPE FRNO SHPOS FLOOR ROW FRPOS EQPEC LOAD

CARY RCC2 0
 1101 CRSC 0 5 0 C 0 MX85AA CRI08xx
EXECTAB
(POTS POTSEX) (KEYSET KSETEX) (RMM_TERM RSMEX) (ESALINES ESAEX) $
CSPM CSLNKTAB

LTC 1 (0) (1) (2) (3) (4) (5) (6) (7)
ESA INTRASW OPTCARD CMRLOAD CONTMARK
Y Y (UTR6) (NT7X05AA 7) (MSG6X69) (CMR5 CMRAG03) (ISP16) $
TONESET PROCPEC E2LOAD EXTINFO
NORTHAM MX77AA MX77AA MX77xxxx CEXT 0 4 0 E 15 MX86AA L

```

**Note 1:** xx in field LOAD and xxxxx in field E2LOAD represent alphanumeric entries, for example B1 and XE01, respectively.

**Note 2:** If the shelf is equipped with a processor other than NTMX77 or the optional NTAX74, field E2LOAD is automatically datafilled with value NILLOAD.

**Note 3:** When field PROCPEC is datafilled with AX74AA AX74AA instead of MX77AA MX77AA, the load name prefix in field LOAD changes from CRI to XRI. For example, CRI08xx (for MX77) changes to XRI08XX (for AX74AA). The following example shows sample datafill for table RCCINV when the RCC2 is datafilled for the NTAX74AA CAP.

## Enhanced ESA for ISDN (Lines and Trunks) (continued)

### MAP display example for table RCCINV datafilled for NTAX74AA CAP

```

Table: RCCINV
RCCNAME FRTYPE FRNO SHPOS FLOOR ROW FRPOS EQPEC LOAD

CARY RCC2 0
 1101 CRSC 0 5 0 C 0 MX85AA XRI08xx
EXECTAB
(POTS POTSEX) (KEYSET KSETEX) (RMM_TERM RSMEX) (ESALINES ESAEX) $
CSPM CSLNKTAB
LTC 1 (0) (1) (2) (3) (4) (5) (6) (7) $
ESA INTRASW OPTCARD CMRLOAD CONTMARK
Y Y (UTR6) (MSG6X69) (CMR5 CMRAG03) (ISP16) $
TONESET PROCPEC E2LOAD EXTINFO
NORTHAM AX74AA AX74AA AX74xxxxx CEXT 0 4 0 E 15 MX86AA L

```

### Datavfilling table ESAPXLA

The following table shows the datafill specific to Enhanced ESA for ISDN (Lines and Trunks) for table ESAPXLA. Only those fields that apply directly to Enhanced ESA for ISDN (Lines and Trunks) are shown. For a description of the other fields, refer to the *Translation Guide*.

#### Datavfilling table ESAPXLA (Sheet 1 of 3)

| Field   | Subfield or refinement | Entry                                  | Explanation and action                                                                                                                                                                                                                                  |
|---------|------------------------|----------------------------------------|---------------------------------------------------------------------------------------------------------------------------------------------------------------------------------------------------------------------------------------------------------|
| PXLAKEY |                        | alphanumeric                           | Prefix translator key. This key identifies a set of prefix digits on a certain site for a particular set of customers. Subfields: XLANAME, NODE, and PREFIX.                                                                                            |
|         | XLANAME                | alphanumeric<br>(8 characters maximum) | Prefix translator name. If this translation is to be performed for any POTS line on the remote, enter ESAPOTS. If it is to be performed for a particular IBN customer group, enter any name and relate this name to a customer group in table CUSTHEAD. |

**Enhanced ESA for ISDN (Lines and Trunks)** (continued)

Datafilling table ESAPXLA (Sheet 2 of 3)

| Field  | Subfield or refinement | Entry        | Explanation and action                                                                                                                                                                                                                             |
|--------|------------------------|--------------|----------------------------------------------------------------------------------------------------------------------------------------------------------------------------------------------------------------------------------------------------|
|        | NODE                   | alphanumeric | Node. The RLCM, RCC, RCC2, or remote digital line module (RDLM) associated with the translator identified by XLANAME. Subfields: PMTYPE, LCMNO, SITE, and RCCNO.                                                                                   |
|        | PMTYPE                 | RCC2         | Peripheral module type. This field identifies the peripheral node as either an RLCM, an RCC, an RCC2, or an RDLM.                                                                                                                                  |
|        | SITE                   | alphanumeric | Site. Enter the RCC2 location name.                                                                                                                                                                                                                |
|        | RCCNO                  | 0 to255      | RCC2 number. Enter the RCC2 PM number.                                                                                                                                                                                                             |
|        | PREFIX                 | numeric      | Prefix digit. Enter the 1- to 15-digit prefix with which the translation is to be associated.                                                                                                                                                      |
| RESULT |                        | alphanumeric | Translation result. This field defines the action to take when previously defined prefix digits are dialed on the remote. Subfield: SEL and entries contingent on the value entered for SEL.                                                       |
| SEL    |                        | L            | Selection. If the entry in PREFIX specifies a line, enter L and complete fields LEN, AMBIG, and RNGCD.                                                                                                                                             |
|        | LEN                    | alphanumeric | Line equipment number. This field defines the line where the call is to terminate. Fields: SITE, FRAME, UNIT, LSG, and CIRCUIT.                                                                                                                    |
|        | SITE                   | alphanumeric | Site. Enter the name assigned to the site where the termination line is located. Since the remote is operating in ESA, there is no communication with the host. The site name must match the site name specified in subfield NODE.                 |
|        | FRAME                  | 0-99         | Frame. Enter the frame number at this site that contains the line card for the termination line. For PMTYPE RCC2, communication is supported between all of the line concentrating modules (LCM) or the digital line modules attached to the RCC2. |
|        | UNIT                   | 0 or 1       | Unit. Enter the unit number of the LCM, RLCM, digital line module, or RDLM to which the line is assigned.                                                                                                                                          |

---

**Enhanced ESA for ISDN (Lines and Trunks) (continued)**


---

**Datafilling table ESAPXLA (Sheet 3 of 3)**

| Field | Subfield or refinement | Entry  | Explanation and action                                                                                                                                     |
|-------|------------------------|--------|------------------------------------------------------------------------------------------------------------------------------------------------------------|
|       | LSG                    | 0-19   | Line subgroup. Enter the number of the line subgroup of the LCM, RLCM, digital line module, or RDLM unit in which the line card for that line is assigned. |
|       | CIRCUIT                | 0-31   | Circuit. Enter the line card circuit number of the line subgroup where the line card is assigned.                                                          |
|       | AMBIG                  | Y or N | Ambiguous. Entry values: Y (the same digits may be dialed as the first digits of another number) and N (the prefix digits are unique).                     |
|       | RNGCD                  | 0-7    | Ring code. Enter the code for the type of ringing associated with the line specified in the LEN field. This is for lines on an LCM or digital line module. |

**Datafill example for table ESAPXLA**

The following example shows sample datafill for table ESAPXLA.

**MAP display example for table ESAPXLA**

```

Table: ESAPXLA
 PXLKEY

ESAPOTS RCC2 CARY 0 411
IBN1 RCC2 CARY 0 6
IBN1 RCC2 CARY 0 9
ESATEST RCC2 CARY 0 611

 RESULT

L CARY 00 0 00 02 Y 1
T SRPXLA
T SRPDXLA
L CARY 02 0 01 20 N 1

```

**Datafilling table CUSTHEAD**

The following table shows the datafill specific to Enhanced ESA for ISDN (Lines and Trunks) for table CUSTHEAD. Only those fields that apply

## Enhanced ESA for ISDN (Lines and Trunks) (continued)

directly to Enhanced ESA for ISDN (Lines and Trunks) are shown. For a description of the other fields, refer to the *Translation Guide*.

### Datafilling table CUSTHEAD

| Field   | Subfield or refinement | Entry        | Explanation and action                                                                                                         |
|---------|------------------------|--------------|--------------------------------------------------------------------------------------------------------------------------------|
| OPTIONS |                        | ESAPXLA      | Option. This field lists options and subfields assigned to the customer group. Enter option ESAPXLA.                           |
|         | XLANAME                | alphanumeric | Prefix translator name. Enter the 1 to 8 characters assigned to the prefix translator table in field XLANAME of table ESAPXLA. |

### Datafill example for table CUSTHEAD

The following example shows sample datafill for table CUSTHEAD.

### MAP display example for table CUSTHEAD

```

Table CUSTHEAD
CUSTNAME CUSTXLA DGCOLNM IDIGCOL

POTSDATA POTSXLA POTS NIL
COMIBN2 CXN2 IBN2 NIL
 OPTIONS

(SUPERCNF)(MHOLD 10 AUDIO)(CPR Y AUDIO1 3)
(ESAPXLA IBN1)

```

### Datafilling table ESAHNP

The following table shows the datafill specific to Enhanced ESA for ISDN (Lines and Trunks) for table ESAHNP. Only those fields that apply directly

## Enhanced ESA for ISDN (Lines and Trunks) (continued)

to Enhanced ESA for ISDN (Lines and Trunks) are shown. For a description of the other fields, refer to the *Translation Guide*.

**Datafilling table ESAHNPA (Sheet 1 of 2)**

| Field                                                                                                                                                                                                                                                                                                                                                            | Subfield or refinement | Entry                               | Explanation and action                                                                                                                                                                                                                                                |
|------------------------------------------------------------------------------------------------------------------------------------------------------------------------------------------------------------------------------------------------------------------------------------------------------------------------------------------------------------------|------------------------|-------------------------------------|-----------------------------------------------------------------------------------------------------------------------------------------------------------------------------------------------------------------------------------------------------------------------|
| HNPAKEY                                                                                                                                                                                                                                                                                                                                                          |                        | alphanumeric                        | Field long name: ESAHNPA KEY. Identifies a set of prefix digits on a certain site for a particular set of customers. Subfields: XLANAME, NODE, and PREFIX.                                                                                                            |
|                                                                                                                                                                                                                                                                                                                                                                  | XLANAME                | alphanumeric (8 characters maximum) | Prefix translator name. If this translation is to be performed for any POTS line on the remote, enter ESAPOTS. If this translation is to be performed for a particular IBN customer group, enter any name and relate this name to a customer group in table CUSTHEAD. |
|                                                                                                                                                                                                                                                                                                                                                                  | NODE                   | alphanumeric                        | Node. This field is the RCLM or RCC2 node associated with the translator identified by XLANAME. Subfields: PMTYPE, SITE, AND RCCNO.                                                                                                                                   |
|                                                                                                                                                                                                                                                                                                                                                                  | PMTYPE                 | RCC2                                | Peripheral module type. Identifies the PM as an RCC2. SITE and RCCNO must be datafilled.                                                                                                                                                                              |
|                                                                                                                                                                                                                                                                                                                                                                  | SITE                   | alphanumeric                        | Site. Enter the RCC2 location name.                                                                                                                                                                                                                                   |
|                                                                                                                                                                                                                                                                                                                                                                  | RCCNO                  | numeric                             | RCC2 number. Specifies the RCC2 number as identified in the key field of table RCCINV.                                                                                                                                                                                |
|                                                                                                                                                                                                                                                                                                                                                                  | PREFIX                 | numeric (15 digits maximum)         | Prefix digit. Enter the prefix associated with the translation.                                                                                                                                                                                                       |
| RESULT                                                                                                                                                                                                                                                                                                                                                           |                        | alphanumeric                        | Translation result. Defines the action to take when the previously defined prefix digits are dialed on the remote. Subfields: SEL, RR, NUMDIG and AMBIG.                                                                                                              |
|                                                                                                                                                                                                                                                                                                                                                                  | SEL                    | R                                   | Selector. If the prefix digits entered in the PREFIX field specify a standard route, enter R and complete RR, NUMDIG, and AMBIG.                                                                                                                                      |
| <p><b>Note:</b> For an AMBIG selection, digits 123 would be considered ambiguous if another acceptable number was 12356. If N is entered, the switching process begins immediately after those prefix digits are dialed. If Y is entered, the remote waits for further digits. If none are entered during a given time period, the switching process begins.</p> |                        |                                     |                                                                                                                                                                                                                                                                       |

**Enhanced ESA for ISDN (Lines and Trunks) (end)**

**Datafilling table ESAHNPA (Sheet 2 of 2)**

| Field | Subfield or refinement | Entry  | Explanation and action                                                                                                                 |
|-------|------------------------|--------|----------------------------------------------------------------------------------------------------------------------------------------|
|       | RR                     | 0-255  | Route reference index. Specify the index of the route described in ESARTE where translation is to proceed.                             |
|       | NUMDIG                 | 0-15   | Collect digit. Specify the number of digits to collect before outpulsing.                                                              |
|       | AMBIG                  | Y or N | Ambiguous. Entry values: Y (the same digits may be dialed as the first digits of another number) and N (the prefix digits are unique). |

**Note:** For an AMBIG selection, digits 123 would be considered ambiguous if another acceptable number was 12356. If N is entered, the switching process begins immediately after those prefix digits are dialed. If Y is entered, the remote waits for further digits. If none are entered during a given time period, the switching process begins.

**Datafill example for table ESAHNPA**

The following example shows sample datafill for table ESAHNPA.

**MAP display example for table ESAHNPA**

```

Table: ESAHNPA

HNPKEY RESULT

ESAPOTS RCC2 CARY 0 321 R 1 7 N

```

**SERVORD**

Enhanced ESA for ISDN (Lines and Trunks) does not use SERVORD.



## **HSTP0 DMS ADSL Capability**

---

### **Ordering codes**

Functional group ordering code: HSTP0002

Functionality ordering code: Not Applicable

### **Release applicability**

NA008/XPM81 and up

HSTP0 DMS ADSL Capability was introduced in CCM07.

### **Prerequisites**

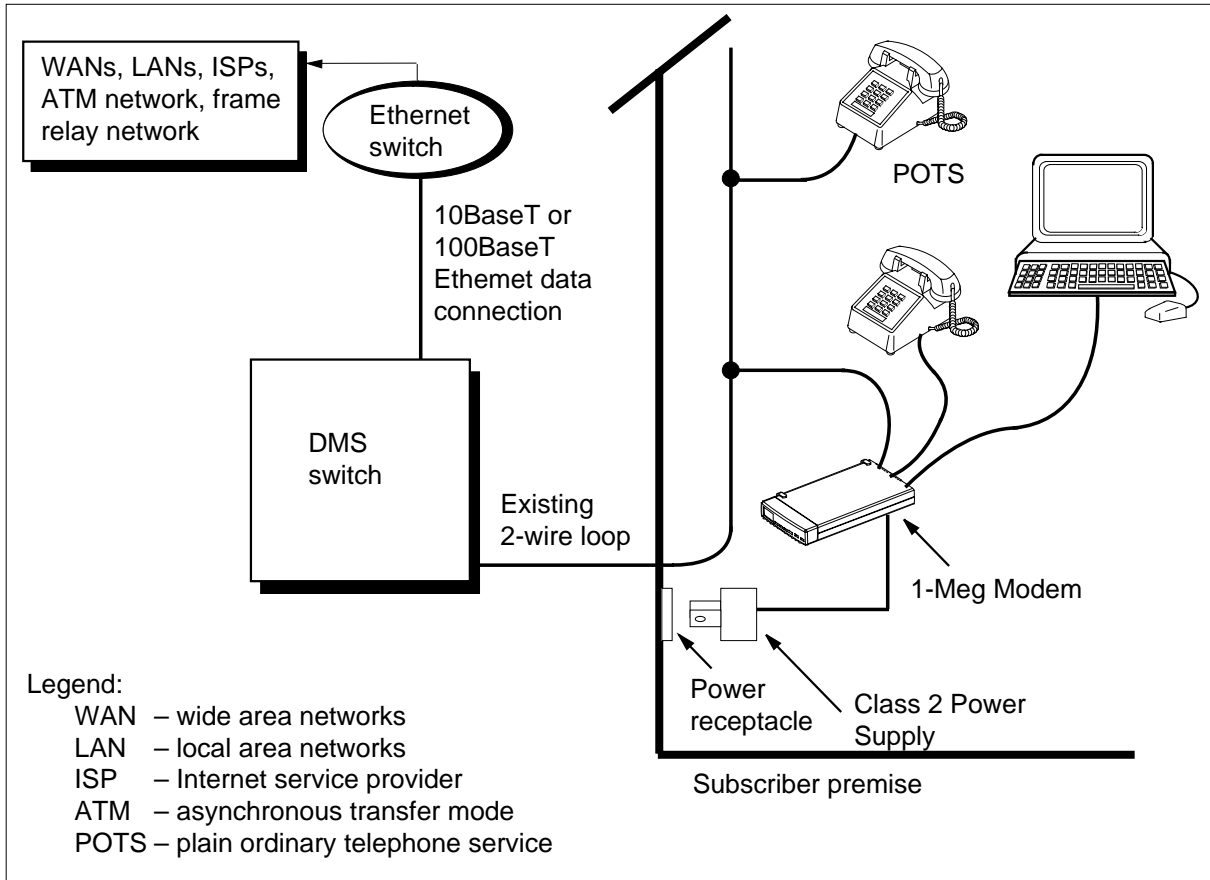
HSTP0 DMS ADSL Capability has no prerequisites.

### **Description**

HSTP0 DMS ADSL Capability provides the software to allow a line concentrating module (LCM) located at a remote site to provision and maintain 1-Meg Modem Service hardware. The following figure illustrates the 1-Meg Modem Service.

## HSTP0 DMS ADSL Capability (continued)

### 1-Meg Modem Service network



## Operation

Before to this enhancement, LCM subscribers were limited to analog modem speed rates of 56 kbit/s. With analog modems, the subscriber cannot use POTS and data services at the same time. Additionally, data calls typically have longer holding times that reduce the operating company's traffic call hundredth seconds (CCS) values. HSTP0 DMS ADSL Capability addresses these limitations by:

- supports simultaneous use of data and all voice services
- increases data transmission rates
  - up to 1280 kbit/s downstream
  - up to 320 kbit/s upstream
- routing data traffic away from the DMS-100, to reduce the impact on the office's CCS values.

---

## HSTP0 DMS ADSL Capability (continued)

---

### Components

The 1-Meg Modem Service includes the following components:

- The 1-Meg Modem is customer-premise equipment (CPE) that connects the telephone line, extension telephone, and personal computer (PC). To the subscriber, the modem installs like a regular voice band modem, except the modem uses a 10BaseT Ethernet connection to the computer. Voice and data circuits are kept separate on the loop. This allows simultaneous voice and data traffic with no impact to other telephony features.
- An xDSL line card (xLC) replaces the subscriber's line card in an existing line concentrating module (LCM) drawer. The card provides full voice service in parallel with high-speed data communication with the 1-Meg Modem.
- A data-enhanced bus interface card (DBIC) replaces the existing bus interface card (BIC) in the existing LCM drawer. The card provides a concentrating function for the voice and data connections within a single LCM drawer. The card also separates the voice and data traffic for routing to the appropriate networks.
- The xDSL Element Management System (xEMS) provides operations, administration, maintenance, and provisioning (OAM&P) functions from a Hewlett-Packard (HP) or Sun workstation. Based on HP OpenView, the xEMS is a graphical user interface (GUI) that uses icons and pull-down menus.

The DBIC and xLCs are backwards compatible with the current bus interface (BIC) and line card (LC) architecture. You can add either component without affecting existing subscriber features or services. The LCM handles all 1-Meg Modem Service voice traffic like existing plain old telephone service (POTS) calls.

### Human machine interface (HMI)

This feature introduces a new command interpreter (CI) command: QXNET. Enter the QXNET command to query the engineering rules validation routines and format the output.

### Translations table flow

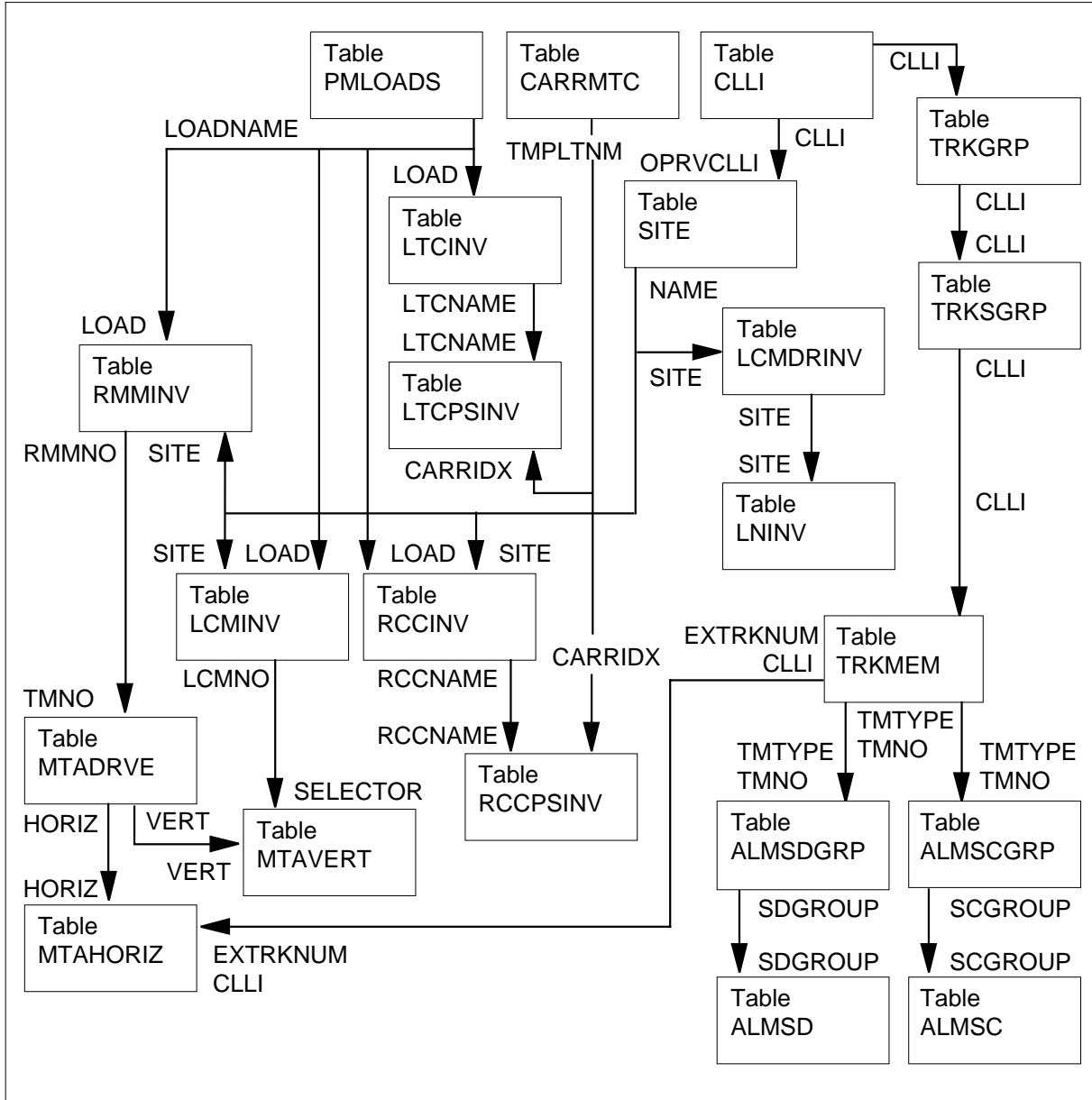
The HSTP0 DMS ADSL Capability translations tables are described in the following list:

- Table LCMDRINV
- Table LNINV

## HSTP0 DMS ADSL Capability (continued)

The following figure illustrates the HSTP0 DMS ADSL Capability translation process.

### Translations process for HSTP0 DMS ADSL Capability

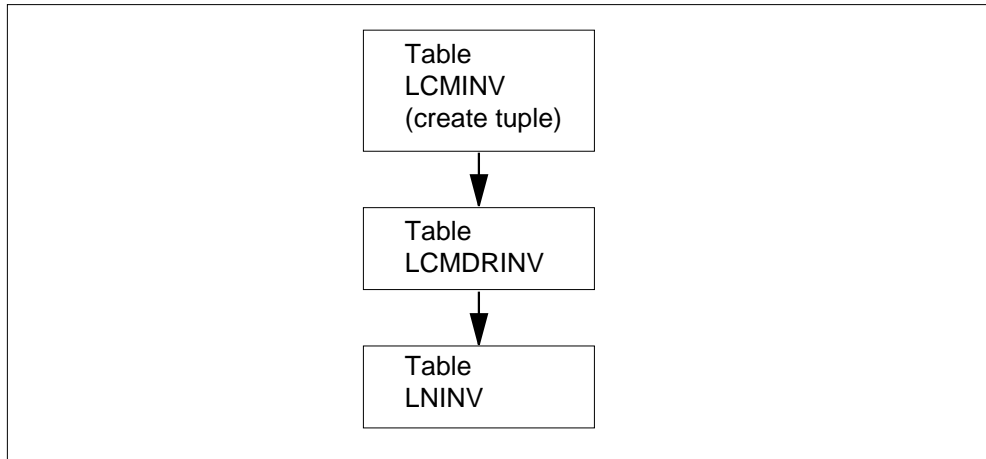


The following figure illustrates the table flow to datafill HSTP0 DMS ADSL Capability.

---

**HSTP0 DMS ADSL Capability** (continued)

---

**HSTP0 DMS ADSL Capability table flow**

The datafill content for the tables in the previous flowchart follows:

- Table LCMINV lists data assignments for each LCM or remote LCM (RLCM). Field SITE in table LCMINV matches the NAME tuple from table SITE. This field identifies the equipment for the switching unit and for all remote locations connected to the unit. Field LOAD in table LCMINV matches the LOADNAME tuple from table PMLOADS. This field stores the device location of each PM load file.
- Table LCMDRINV lists the LCM name, physical drawer numbers, product engineering code (PEC) of the drawers, drawer loadname, and media access control (MAC) address for each LCM or RLCM. The line drawer applications use the information in this table to determine the functionality supported in each physical drawer.

Table LCMDRINV only supports change operations and does not support manual additions or deletions. The switch automatically adds and deletes tuples to this table when a matching entry is made in table LCMINV.

- Table LNINV lists the site name with the line equipment number (LEN), and other data for each line card circuit in an office.

## **HSTP0 DMS ADSL Capability** (continued)

---

### **Limitations and restrictions**

The following limitations and restrictions apply to HSTP0 DMS ADSL Capability:

- Each drawer entered in table LCMDRINV to support HSTP0 DMS ADSL Capability must have a DBIC.
- Each drawer with a DBIC must have an xLC to support HSTP0 DMS ADSL Capability. If the drawer does not have a DBIC, the xLC will only provide voice services.
- If the LCM is an RLCM, the line drawer supports only NTEX17DA xLCs and NTEX54CA DBICs.
- The 1-Meg Modem Service subscriber must have a 1-Meg Modem.
- When a tuple is added or deleted in table LCMINV, a corresponding tuple is automatically added or deleted in table LCMDRINV.

### **Interactions**

HSTP0 DMS ADSL Capability has no functionality interactions.

### **Activation/deactivation by the end user**

HSTP0 DMS ADSL Capability requires no activation or deactivation by the end user.

### **Billing**

HSTP0 DMS ADSL Capability does not affect billing.

### **Station Message Detail Recording**

HSTP0 DMS ADSL Capability does not affect Station Message Detail Recording (SMDR).

### **Datafilling office parameters**

HSTP0 DMS ADSL Capability does not affect office parameters.

## HSTP0 DMS ADSL Capability (continued)

### Datafill sequence

The following table lists the tables that require datafill to implement HSTP0 DMS ADSL Capability. The tables are listed in the order in which they are to be datafilled.

#### Datafill tables required for HSTP0 DMS ADSL Capability

| Table    | Purpose of table                                                                                  |
|----------|---------------------------------------------------------------------------------------------------|
| LCMDRINV | Line Concentrating Module Drawer Inventory. Lists data assignment for each drawer for a LCM unit. |
| LNINV    | Line Circuit Inventory. Lists the data for each line card slot.                                   |

### Datafilling table LCMDRINV

Verify the following datafill related to HSTP0 DMS ADSL Capability for table LCMDRINV. The following table only lists the fields that apply to HSTP0 DMS ADSL Capability. Refer to the *Translations Guide* for a description of the other fields.

#### Datafilling table LCMDRINV (Sheet 1 of 2)

| Field                                                                                                                                                                                                                                                                                                                                                                                                                                     | Subfield or refinement | Entry    | Explanation and action                                         |
|-------------------------------------------------------------------------------------------------------------------------------------------------------------------------------------------------------------------------------------------------------------------------------------------------------------------------------------------------------------------------------------------------------------------------------------------|------------------------|----------|----------------------------------------------------------------|
| LCMNM                                                                                                                                                                                                                                                                                                                                                                                                                                     |                        |          | LCM name. Entry made up of subfields SITE, PM_type, and PM_no. |
|                                                                                                                                                                                                                                                                                                                                                                                                                                           | SITE                   | REM1     | Site name. Enter the name of the site of this LCM.             |
|                                                                                                                                                                                                                                                                                                                                                                                                                                           | FRAME                  | 0 to 511 | Frame number. Enter the LCM frame number.                      |
| DRWRTAB                                                                                                                                                                                                                                                                                                                                                                                                                                   | PM_NO                  | 0 to 255 | Peripheral module number. Enter PM number for this LCM.        |
|                                                                                                                                                                                                                                                                                                                                                                                                                                           | PHYDRNO                | 0 to 9   | The physical drawer number.                                    |
| <p><b>Note 1:</b> Changes to fields with multiple entries should be made in the PROMPT mode only. In nonprompt mode it is possible to leave out existing entries.</p> <p><b>Note 2:</b> Enter the continuation mark (+) in fields with multiple possible entries when more data is specified on the next line or more records will be entered. Enter the end mark (\$) in fields with multiple possible entries after the last entry.</p> |                        |          |                                                                |

**HSTP0 DMS ADSL Capability** (continued)

Datafilling table LCMDRINV (Sheet 2 of 2)

| Field | Subfield or refinement | Entry                                                                     | Explanation and action                                                                                                                                                                                                                                                                                                                                                                    |
|-------|------------------------|---------------------------------------------------------------------------|-------------------------------------------------------------------------------------------------------------------------------------------------------------------------------------------------------------------------------------------------------------------------------------------------------------------------------------------------------------------------------------------|
|       | LDCPEC                 | NTEX54AA,<br>NTEX54AB,<br>NTEX54BA,<br>NTEX54CA                           | Line drawer control card PEC. Enter the PEC code of the DBIC.                                                                                                                                                                                                                                                                                                                             |
|       | DRWRPEC                | NT6X05AA,<br>NT6X05BA,<br>NT6X05CA,<br>NT6X05DA,<br>NT6X05EA,<br>NTBX32BA | The physical line drawer PEC                                                                                                                                                                                                                                                                                                                                                              |
|       | MACADDRESS             | 12<br>hexidecimal<br>digits                                               | Media Access Control (MAC) layer address. The Ethernet address, also known as the hardware physical address, obtained from stamping on the DBIC. This number must be unique and correspond to the number on the DBIC.                                                                                                                                                                     |
|       | IPADDR                 | 4 digits, with<br>each digit<br>ranging from<br>0 to 255                  | IP Address The Internet Protocol (IP) address of the LCM line drawer. The default is 0 0 0 0. This subfield only applies when you use the 1MMS option in SERVORD to provision 1-Meg Modem Service. The value in this subfield can be the default (0 0 0 0) or any IP value if the office does not support 1-Meg Modem Service or you do not use SERVORD to provision 1-Meg Modem Service. |

**Note 1:** Changes to fields with multiple entries should be made in the PROMPT mode only. In nonprompt mode it is possible to leave out existing entries.

**Note 2:** Enter the continuation mark (+) in fields with multiple possible entries when more data is specified on the next line or more records will be entered. Enter the end mark (\$) in fields with multiple possible entries after the last entry.

**Datafill example for table LCMDRINV**

The following example shows sample datafill for table LCMDRINV.



---

**HSTP0 DMS ADSL Capability** (continued)

---

**MAP display example for table LCMDRINV**

```

TABLE LCMDRINV

LCMNM DRWRTAB

REMI 00 0
(0 NT6X54AA NT6X05AA) (1 NILDRWR) (2 NTEX54BA NT6X05EA
EEFF00010203 0 0 0 0) (3 NILDRWR) (4 NTEX54BA NT6X05EA
FF0001020304 0 0 0 0) (5 NILDRWR) (6 NILDRWR) (7 NILDRWR) (6
NTEX54BA NT6X05EA 000102030405 0 0 0 0) (7 NTEX54AA NT6X05EA
010203040506 0 0 0 0) (8 NTEX54BA NT6X05EA 010203040507 0 0
0 0) (9 NILDRWR)$

```

**Error messages for table LCMDRINV**

The following error messages apply to table LCMDRINV.

**Error messages for table LCMDRINV**

| Error message                                                                        | Explanation and action                                                    |
|--------------------------------------------------------------------------------------|---------------------------------------------------------------------------|
| Tuple Addition occurs when the corresponding entry is added into the LCMINV table.   | An attempt was made to manually add a tuple entry into table LCMDRINV.    |
| Tuple Deletion occurs when the corresponding entry is deleted from the LCMINV table. | An attempt was made to manually delete a tuple entry from table LCMDRINV. |

**Datafilling table LNINV**

Table LNINV matches the site name from table SITE to each physical line circuit in the LCM. This table defines the LEN of a line and indicates the software location and its hardware characteristics. Each line card in the LCM has a tuple in table LNINV.

The subfields used to identify the line card are changed so a LEN can identify an LCM line card. In a LEN for an LCM, the fields for the LEN are defined as follows:

- SITE
- FRAME
- UNIT

## HSTP0 DMS ADSL Capability (continued)

- SUBGROUP
- CIRCUIT

Note the following table interactions:

- The line assignment for coin lines is made in table LENLINES. The LNATTIX field matches to the line class, code, coin first (CCF), coin dial tone first (CDF), or coin semi-postpay (CSP), in table LINEATTR.
- POTS lines LCMLSG do not have matching tuples in keyset-type tables.
- For Meridian business sets (MBS), the VARTYPE in table LCMINV must be NTPROP.

The following table shows the datafill related to HSTP0 DMS ADSL Capability for table LNINV. The table only lists those fields that apply directly to HSTP0 DMS ADSL Capability.

For a description of the other fields, refer to the data schema section of this document.

### Datafilling table LNINV (Sheet 1 of 2)

| Field | Subfield or refinement | Entry        | Explanation and action                                                                                                                               |
|-------|------------------------|--------------|------------------------------------------------------------------------------------------------------------------------------------------------------|
| LEN   |                        | alphanumeric | Line equipment number. This field contains the following subfields: SITE, FRAME, UNIT, SUBGROUP, and CIRCUIT.                                        |
|       | SITE                   | alphanumeric | Site. Enter the location of the LCM (four-character alphanumeric). This entry is not optional, and there is no default value assigned to it.         |
|       | FRAME                  | 0 to 511     | LCM frame. Enter the LCM frame number, which is not a physical frame but a software entity that represents the group the LCM belongs to at the site. |
|       | UNIT                   | 0 to 1       | LCM unit. Enter the number representing the LCM unit within the group.                                                                               |
|       | SUBGROUP               | 0 to 19      | LCM subgroup. Enter the number of subgroups in the line drawers.                                                                                     |

**HSTP0 DMS ADSL Capability** (continued)

Datafilling table LNINV (Sheet 2 of 2)

| Field    | Subfield or refinement | Entry                                               | Explanation and action                                                                                                                                                                                                   |
|----------|------------------------|-----------------------------------------------------|--------------------------------------------------------------------------------------------------------------------------------------------------------------------------------------------------------------------------|
|          | CIRCUIT                | 0 to 31                                             | LCM circuit. Enter the number of circuits in the subgroups. The range is 0-31.                                                                                                                                           |
| CARDCODE |                        | EX17AA, EX17BA,<br>EX17CA, EX54DA                   | Card code. Enter the PEC of the line card or line card carrier.                                                                                                                                                          |
| PADGRP   |                        | STDLN, UNBAL, PPHON,<br>LRLM, NPDGP and ONS         | Pad group. Enter the name of the pad group assigned to the line circuit in the pad data table. The values include STDLN, UNBAL, PPHON, LRLM, NPDGP, and ONS.                                                             |
| STATUS   |                        | HASU, WORKING,<br>UNEQUIP, CUTOFF, and<br>RESERVED. | Status. Enter the line inventory availability status. The values include HASU, WORKING, UNEQUIP, CUTOFF, and RESERVED.                                                                                                   |
| GND      |                        | Y or N                                              | Ground. Where line is ground start, enter Y. Otherwise, enter N (for loop start).                                                                                                                                        |
| BNV      |                        | L or NL                                             | Balanced network value. Enter L when line circuit is configured for a loaded network. Otherwise, enter NL (for nonloaded network).                                                                                       |
| MNO      |                        | Y or N                                              | Manual override. Enter Y when on-hook balance network test is to be prevented from updating field BNV in this table.<br><br>Otherwise, enter N to allow off-hook balance network test to update field BNV in this table. |
| CARDINFO |                        | NIL                                                 | Card information. The NIL value is the default. The values are NIL, SSLCC, or ISLCC.                                                                                                                                     |

**Datafill example for table LNINV**

The following example shows sample datafill for table LNINV.

---

## HSTP0 DMS ADSL Capability (end)

---

### MAP display example for table LNINV

| LEN  | CARDCODE | PADGRP | STATUS | GND    | BNV     | MNO | CARDINFO |
|------|----------|--------|--------|--------|---------|-----|----------|
| REM1 | 00 0 0   | 01     | EX17CA | STD LN | HASU    | N   | NL N NIL |
| REM1 | 00 0 0   | 02     | EX17CA | STD LN | HASU    | N   | NL N NIL |
| REM1 | 00 0 0   | 03     | EX17CA | STD LN | WORKING | N   | NL N NIL |
| REM1 | 00 0 0   | 04     | EX17CA | STD LN | WORKING | N   | NL N NIL |
| REM1 | 00 0 0   | 05     | EX17CA | STD LN | HASU    | N   | NL N NIL |
| REM1 | 00 0 0   | 06     | EX17CA | STD LN | HASU    | N   | NL N NIL |
| REM1 | 00 0 0   | 07     | EX17CA | STD LN | WORKING | N   | NL N NIL |
| REM1 | 00 0 0   | 08     | EX17CA | STD LN | WORKING | N   | NL N NIL |
| REM1 | 00 0 0   | 09     | 6X17BA | STD LN | HASU    | N   | NL N NIL |
| REM1 | 00 0 0   | 10     | 6X17BA | STD LN | HASU    | Y   | NL N NIL |
| REM1 | 00 0 5   | 00     | 6X17BA | STD LN | HASU    | N   | NL N NIL |
| REM1 | 00 0 5   | 01     | 6X17BA | STD LN | HASU    | N   | NL N NIL |

### Translation verification tools

HSTP0 DMS ADSL Capability tables LCMINV and LCMDRINV support 1-Meg Modem Service specific checks through the following table control commands:

>CHECK

>CHECK ALL

### SERVORD

HSTP0 DMS ADSL Capability SERVORD rejects attempts to add the cut-off-on-disconnect (COD) to an xDSL line. Operation of the cut-off-relay interrupts data services on an xDSL line including the COD feature.

---

# 5 Subscriber Carrier Module-100S Remote

---

## Understanding SMS-R translations

The Subscriber Carrier Module-100S Remote (SMS-R) provides an interface between TR-008 compliant digital loop carrier systems and the DMS-100 Remote Switching Center (RSC). The SMS-R is similar to the Subscriber Carrier Module-100S (SMS) in both hardware and function.

The term, remote concentrator SLC-96, is used when referring to TR-008 compliant digital loop carrier system equipment. Shortened versions of the term, RCS, and SLC-96, may be used as well.

## Signaling for SMS-R

This section describes the signaling used by the SMS-R/Remote Concentrator SLC-96 (RCS) subsystem. It includes the SMS-R/RCS signaling format, signaling protocols and the features they support.

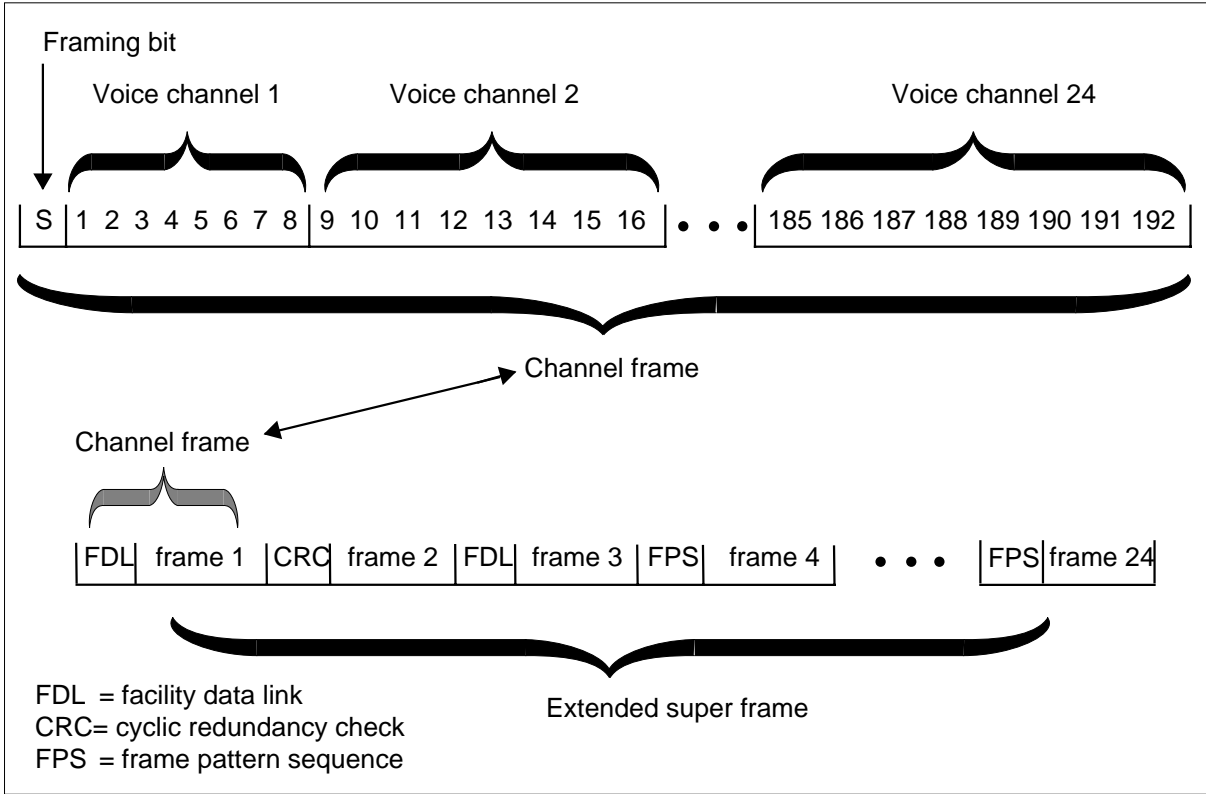
### SMS-R/RCS signaling links

The SMS-R and the RCS exchange information over DS-1 lines using an extended super frame format. DS-1 lines operate at a rate of 1.544 Mbps with a sampling frequency of 8000 frames every second.

The DS-1 link consists of twenty-four channels, each containing 8 bits of pulse code modulation (PCM) data. A framing bit, also referred to as stuffing or S-bit, is included at the front of the sequence, to ensure the SMS-R and the RCS recognize the beginning of each 24-channel sequence. Thus, 192 bits of information are sent during each 24-channel sequence, plus a framing bit. This is referred to as a channel frame.

These channel frames carry either speech information, signaling information or operations information. The following figure is the format of a DS-1 frame.

**Figure 5-1 Format of a DS-1 frame**



As seen in the previous figure, the extended super frame (ESF) consists of 24 DS-1 frames. In ESF, the framing bits, one for each 24-channel frame, forms a 24-bit pattern.

The 24-bit pattern is used to convey three types of information

- frame pattern sequence
- facility data link performance
- cyclic redundancy check

The frame pattern sequence (FPS) is 001110. Every fourth framing bit beginning at the fourth bit carries a FPS bit. Together with the cyclic redundancy check (CRC), the FPS defines an in-frame condition.

The 4Kbit per second facility data link (FDL) bit begins with the first framing bit. An FDL message bit is carried every other frame.

The CRC bit begins with the second bit and is carried every fourth bit. In an extended super frame a block check field is checked six times. The CRC-6 check detects bits emulating an FSP bit and determines if an out-of-frame condition does exist.

A derived data link (DDL) frame, not shown, consists of six superframes or 72 channel frames.

### Signaling protocols

The following signaling protocols are used by the SMS-R/RCS subsystem to communicate and provide subscriber services:

- A- and B-bit messaging
- derived data link (DDL) messaging
- nailed-up cross-connections
- DMS-X protocol

#### A- and B-bit messages

In every sixth and twelfth channel frame, the least significant bits from each channel are stolen, either at the RCS transmit/receive unit card or at the SMS time switch. The least significant bits from the sixth frame are replaced with A-bits. The least significant bits from the twelfth frame are replaced with B-bits. A- and B-bits pass information pertaining to specific channels.

An 8085 microprocessor on the A/B DDL message card sends A- and B-bits to the time switch to be inserted in the PCM data sent to the DS-1 lines. The 8085 microprocessor also extracts A- and B-bits from the PCM data incoming from the time switch. The SMS-R signaling processor (SP) processes the A- and B-bits.

#### DDL messages

As shown in the previous figure, the framing bits used for channel frames alternate between frame timing bits (Ft) and frame signaling bits (Fs). Each superframe has the same sequence of six Ft bits and six Fs bits.

Ft bits identify the first time slot in each channel frame. Fs bits identify the A- (sixth) and B- (twelfth) channel frames of a superframe. The A-frame carries A-bits; the B-frame carries B-bits. The overall framing pattern of Ft and Fs bits is as follows:

```
1(Ft) 0(Fs) 0(Ft) 0(Fs) 1(Ft) 1(Fs) 0(Ft) 1(Fs) 1(Ft) 1(Fs)
0(Ft) 0(Fs)
```

The frame signaling pattern, formed with Fs bits, is as follows:

```
111 000 111 000
```

These 12 bits transfer the signaling pattern from two superframes. The next four superframes are robbed of their Fs bits either at the transmit receive unit card in the RCS or at the time switch card in the SMS-R. Special supervisory

bits are inserted in their place. The 24 consecutive supervisory bits form a special data link called a derived data link (DDL).

The DDL is a 2.2 kilobit/second (Kb/s) data path of supervisory bits always present on the RCS A-link. The DDL also is present on the C-link if shelf group CD is in Mode II, although only a portion of the DDL (the C-field) is used.

### **Nailed-up cross-connections**

To support applications requiring special-service cards, a nailed-up cross-connection (also called a hairpin connection) is set up and maintained through software. This is a peripheral-side (P-side) cross-connection. This means that all information flows from an RCS into the SMS.

Information from the SMS-R is switched to a DS-1 link leading to a second RCS or other piece of digital equipment. Nailed-up peripheral side to peripheral side (P-side to P-side) connections allow voice and signaling information to be routed through the SMS-R only, rather than through the network. Signaling information is not inserted or extracted by the SMS-R.

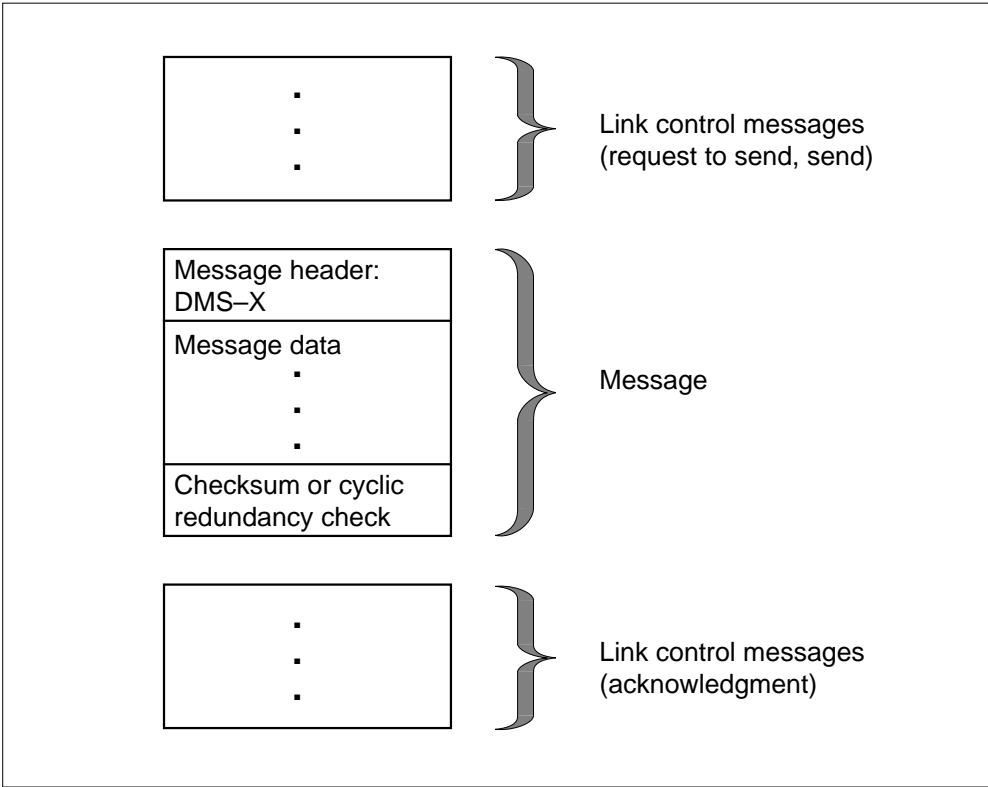
### **DMS-X protocol**

DMS-X protocol is a half-duplex protocol used on DS30A links between the remote cluster controller RCC and the SMS-R. DMS-X protocol includes a cyclic redundancy check (CRC) code for error detection.

DMS-X protocol is an interterminal process containing handshaking messages where two terminals engaged in message transfer inform each other of their present condition with respect to messaging. The following figure illustrates a general form of handshaking protocol, which makes up DMS-X protocol.

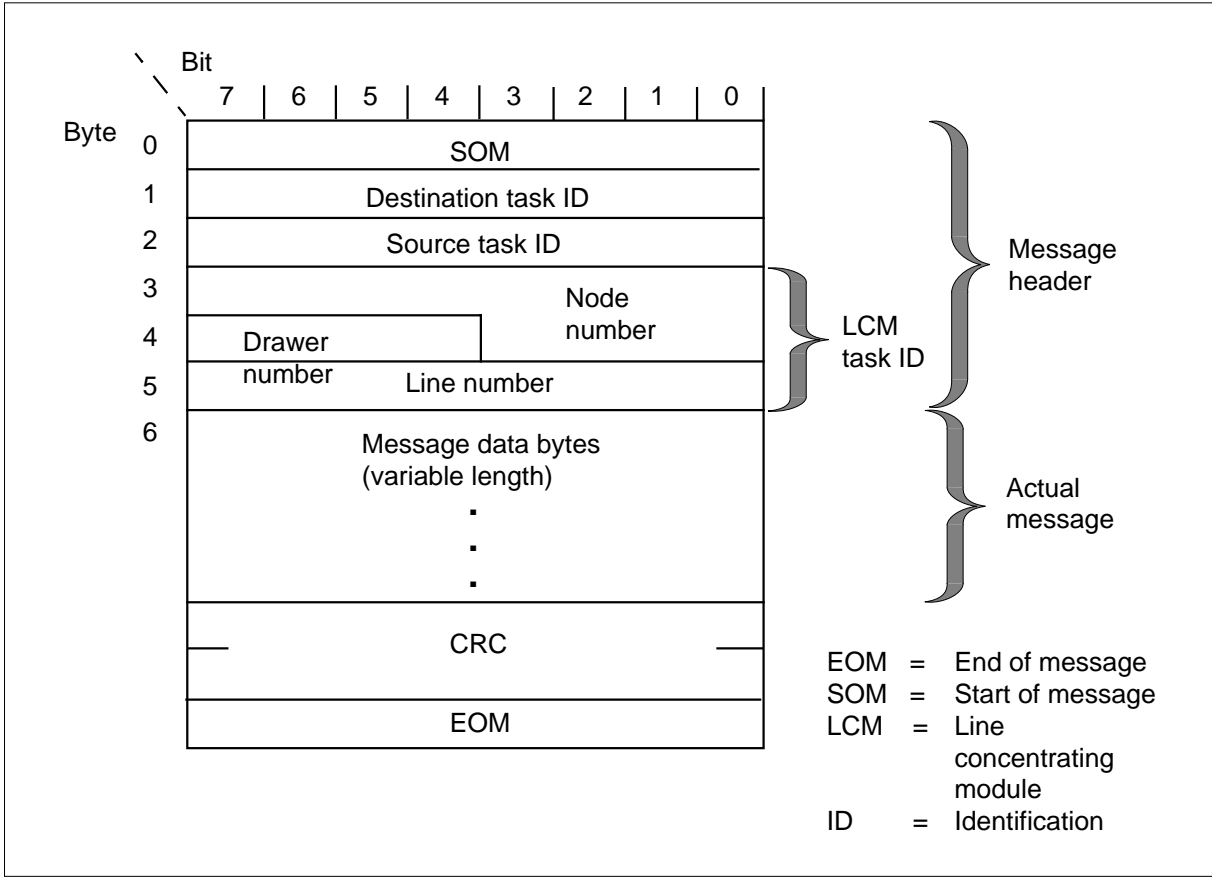


Figure 5-2 DMS-X handshaking protocol



Message error detection is performed by message time-out and by message checksum or CRC calculation. In the event of protocol, checksum, or CRC failure on an outgoing message, the sending node retries the send sequence. On an incoming message failure, the sending node reroutes the message over an alternate control side (C-side) link. Hardware redundancies provide at least one alternative path to and from a node. The format of DMS-X messages is shown in the following figure.

Figure 5-3 DMS-X message format



The message is transmitted over a link, with link control messages preceding and following it. Messaging occurs between programs executing in the SMS-R and in the RCC. Many tasks for processes communicate among themselves by way of messages over the DS30A links.

The DMS-X message header is the first six bytes as follows:

- The first byte is the start of message.
- The second byte is the destination task identification (ID) of the message. This ID is used in an outgoing message to identify the process to receive the message.
- The third byte is the source task ID. This ID is used in an incoming message to identify the process that sent the message.
- The last three bytes are the task ID number.

The number of bytes in the actual message or data is variable. The CRC, occupying two bytes, detects transmission errors. The end of message occupies one byte.

---

## **SMS-R/RCS signaling functions**

### **A- and B-bit messaging**

A- and B-bit messaging supports the subscriber services described below.

**Plain ordinary telephone service (POTS)** POTS is provided for both single-party and multiparty. Multiparty includes: two-party automatic number identification (ANI) and operator number identification (ONI); four- or eight-party ONI.

**Coin features** The following coin features are provided:

- Coin First (CCF)
- Dial Tone First (CDF)
- Coin Semi-Postpay (CSP)

The SMS-R sends the following signaling information to the RCS on a per-channel basis:

- start or stop ringing
- start or stop forward disconnect
- scan for on-hook and off-hook
- collect ANI/coin information
- collect channel maintenance information

The SMS-R collects return signaling information from the RCS that includes the following data:

- call origination
- call disconnect
- digit collection
- ANI/coin
- answer
- flash

A- and B-bit messages are decoded uniquely for each type of RCS line card. A specific pattern indicates something different for a single-party line card and coin card.

**Call processing features** Coin call and ANI processing are grouped as one feature because they use similar software and hardware.

Coin call features apply to coin dial-tone first (CDF) and coin first (CCF) lines and consist of the following capabilities:

- scanning for off-hook
- checking for coin presence
- checking for coin presence during local call overtime
- returning coins
- collecting coins

ANI determines if a two-party line is active from either the tip or the ring side of the line to obtain the correct billing responsibility for a call.

Both ANI and coin features are implemented through A- and B-bit signaling patterns transmitted between the SMS-R and the RCS. These signaling patterns consist of A- and B-bits. Up to nine signaling states are possible. The following signals are transmitted from the SMS-R to the RCS:

- negative loop mode
- channel test
- positive loop mode
- ground start
- -R ringing
- positive coin check
- positive coin control
- negative coin control
- negative coin check

The following signals are transmitted from the RCS to the SMS-R in response to SMS-R signals:

- on-hook
- off-hook
- coin ground
- unequipped

These signaling states are associated with specific A- and B-bit patterns described in the Bellcore document *Digital Interface Between the SLC96 Digital Loop Carrier System and a Local Digital Switch*, TR-TSY-000008.

**PBX line** The private branch exchange line provides capabilities for a loop start and a ground start.

---

**Custom calling services** The following custom calling features are provided:

- Speed Calling
- Call Waiting
- Three-way Calling
- Call Forwarding

**Ringling** The following types of ringling are supported:

- bridged ringling—single-party
- superimposed ringling—multiparty
  - four-party fully selective
  - eight-party semiselective
- coded cadencing
- frequency selective ringling

The SMS-R supports ringling on subscriber lines attached to an RCS. The SMS-R sends different A- and B-bit signaling patterns over DS-1 lines to a connected RCS, causing the RCS to ring subscriber telephone sets.

The DMS-100 switch uses specific signaling patterns for coin, special service, and single- and multiparty lines. These signaling patterns are described in the Bell Communications Research document, *Digital Interface Between the SLC96 Digital Loop Carrier System and a Local Digital Switch*, TR-TSY-000008.

The SMS-R/RCS subsystem supports all currently available types of ringling, including coded, frequency selective ringling (FSR), and superimposed. Only one type of ringling is used at a time on a single RCS.

**Frequency selective ringling** The SMS-R/RCS subsystem supports FSR for single-party, two-party, four-party, and Meridian Digital Centrex (MDC) lines. FSR channel units or cards (referred to as FSR cards in this document) are either SCD222 for 900- $\Omega$  loops or SCD252 for 1500- $\Omega$  loops.

In a specific RCS, only one type of ringling is supported. For example, an RCS supports FSR but not coded, or coded but not FSR. A field in table RCSINV indicates the type of ringling an RCS uses. Refer to the data schema section of the *Translations Guide* for more information on table RCSINV datafill.

All line cards on an RCS use all available types of ringling. If FSR is employed, both single-party and coin line cards can be provisioned on the RCS with FSR cards. Single-party and coin cards employ -R ringling.

Three FSR systems are commonly used: decimonic, harmonic, and synchrononic. Refer to the *Translations Guide* for more information about FSR.

**Dialing** Two types of dialing are supported, dial pulse and Digitone.

**Tones** The following tones are supported:

- dial tone
- audible ringback
- reorder
- busy

**DDL messaging**

The 8085 microprocessor of the A/B DDL message card also sends DDL messages to the time switch included in the DS-1 PCM data stream. It extracts the DDL message from incoming PCM. Software in the SP, called the DDL facility, processes DDL messages.

The DDL message consists of 24 consecutive bits grouped as shown in the DDL message table.

**Table 5-1 DDL message bits and field names (Sheet 1 of 2)**

| DDL bits                                                                                                                                                                                                                                                                                                                                                                                                                                                                                                                                | Field name                       | Explanation                                                                                                                                                                                                                                                                              |
|-----------------------------------------------------------------------------------------------------------------------------------------------------------------------------------------------------------------------------------------------------------------------------------------------------------------------------------------------------------------------------------------------------------------------------------------------------------------------------------------------------------------------------------------|----------------------------------|------------------------------------------------------------------------------------------------------------------------------------------------------------------------------------------------------------------------------------------------------------------------------------------|
| Bits 1 -11                                                                                                                                                                                                                                                                                                                                                                                                                                                                                                                              | Concentrator field (C-field)     | Shelf groups AB and CD use the C-field only when they operate in Mode II. This field carries information for shelves A, B, C, and D, including control of subscriber assignment and deassignment to DS-1 channels, hook transitions, and activation of the PCM looping test. See note 1. |
| Bits 12-14                                                                                                                                                                                                                                                                                                                                                                                                                                                                                                                              | Spoiler bits (fixed pattern 010) | of Spoiler bits are inserted at preassigned positions in the DDL to ensure that no signaling pattern is duplicated by the DDL.                                                                                                                                                           |
| Bits 15-17                                                                                                                                                                                                                                                                                                                                                                                                                                                                                                                              | Maintenance field (M-field)      | The M-field on the A-link carries information for all shelves, and controls card and customer loop testing. See note 2.                                                                                                                                                                  |
| <p><b>Note 1:</b> When no C-field is available to send on the DDL link, the 8085 microprocessor sends an idle pattern on the DDL link. The RCS also sends an idle pattern when no new C-field exists.</p> <p><b>Note 2:</b> If the M-, A-, or S-fields remain unchanged between messages, the 8085 microprocessor sends the previous field patterns. The RCS, at the other end, also sends the same patterns. The 8085 microprocessor sends information to the SP only when a DDL field changes. Idle patterns are not transmitted.</p> |                                  |                                                                                                                                                                                                                                                                                          |

**Table 5-1 DDL message bits and field names (Sheet 2 of 2)**

| DDL bits                                                                                                                                                                                                                                                                                                                                                                                                                                                                                                                                | Field name                                | Explanation                                                                                                                      |
|-----------------------------------------------------------------------------------------------------------------------------------------------------------------------------------------------------------------------------------------------------------------------------------------------------------------------------------------------------------------------------------------------------------------------------------------------------------------------------------------------------------------------------------------|-------------------------------------------|----------------------------------------------------------------------------------------------------------------------------------|
| Bits 18-19                                                                                                                                                                                                                                                                                                                                                                                                                                                                                                                              | Alarm data link field (A-field)           | The A-field on the A-link carries alarm and system control information for all shelves. See note 2.                              |
| Bits 20-23                                                                                                                                                                                                                                                                                                                                                                                                                                                                                                                              | Protection line switch field (S-field)    | The S-field on the A-link controls the switching of the DS-1 protection link. See note 2.                                        |
| Bit 24                                                                                                                                                                                                                                                                                                                                                                                                                                                                                                                                  | Spoiler bit field<br>(fixed pattern of 1) | The spoiler bit is inserted at the preassigned position in the DDL to ensure that no signaling pattern is duplicated by the DDL. |
| <p><b>Note 1:</b> When no C-field is available to send on the DDL link, the 8085 microprocessor sends an idle pattern on the DDL link. The RCS also sends an idle pattern when no new C-field exists.</p> <p><b>Note 2:</b> If the M-, A-, or S-fields remain unchanged between messages, the 8085 microprocessor sends the previous field patterns. The RCS, at the other end, also sends the same patterns. The 8085 microprocessor sends information to the SP only when a DDL field changes. Idle patterns are not transmitted.</p> |                                           |                                                                                                                                  |

### **Nailed-up cross-connections**

Nailed-up connections support the following:

- maintenance and table control for nailed-up specials on SMS-R
- SMS-R special services
- digital dataphone service (DDS) hairpin
- direct inward dial (DID) PBX by hairpin
- foreign exchange service
- integrated local specials

To provide support for applications such as foreign exchange and off-premises extension, one endpoint of the nailed-up connection must terminate on a switch supporting these special services.

**Table control for nailed-up specials on SMS-R** This feature implements CC code to support nailed-up peripheral-side to peripheral-side (P-side to P-side) cross-connections on any DS-1 links located on the same SMS-R.

**Special services feature** The special services feature implements peripheral processor code to support nailed-up P-side to P-side cross-connections on any DS-1 links located on the same RCS.

This feature also provides and maintains connections between pairs of P-side channels, lines, or a combination of lines and channels on an SMS-R in response to a CC request. These connections remain until the CC sends a message to disconnect them.

Connections for special services are as follows:

- line to line
- DS-0 to DS-0
- line to DS-0 or DS-0 to line

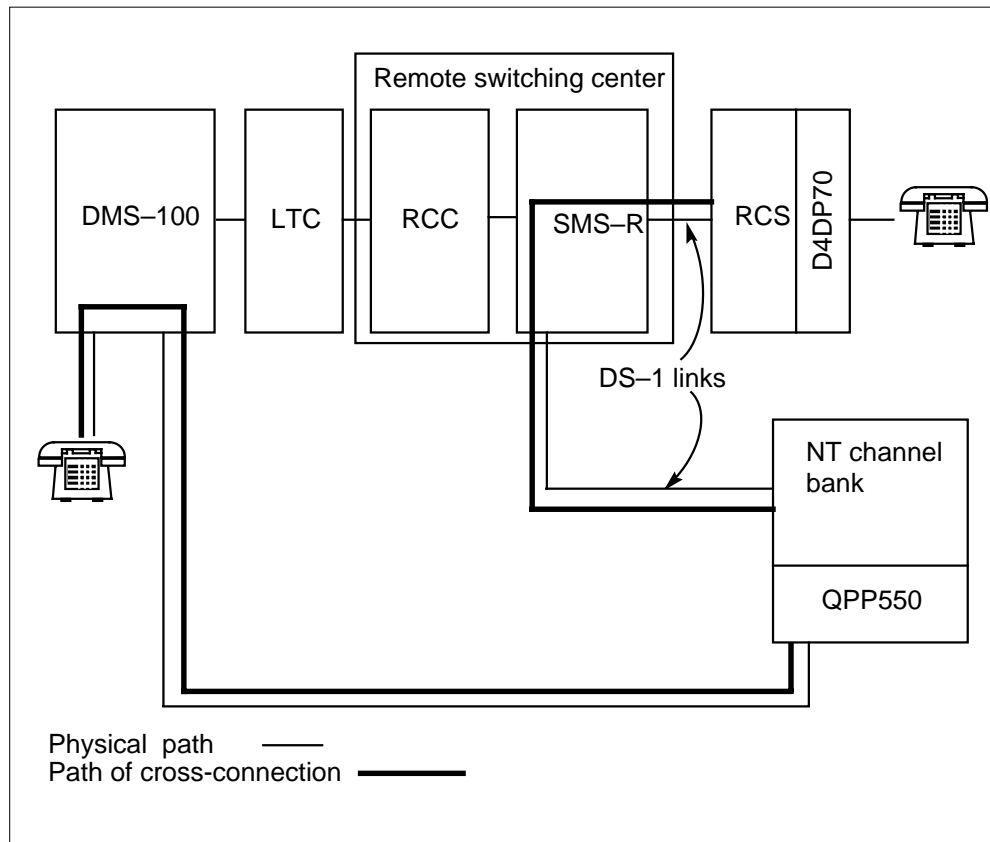
**Digital dataphone service hairpin feature** The Digital dataphone service (DDS) hairpin feature supports 2.4, 4.8, and 9.6 Kb/s data cards. These cards, which transfer data over DS-1 links, employ a nailed-up cross-connection set up by the DMS switch. A typical data path is shown in the following DDS hairpin connection figure.

The 2.4, 4.8, and 9.6 data cards are used for data transmission only. In an NT channel bank they work with an associated card. For example, the D4DP70 card works with the QPP550 card.

The figure of the DDS hairpin connection shows how information flows from the data card through the RCS and SMS-R into a channel bank or some other digital facility, in this case, a Northern Telecom (NT) channel bank. From there, data flows to the DMS-100 and is switched to the terminating party, which could be a computer, another digital switch, or some other device.



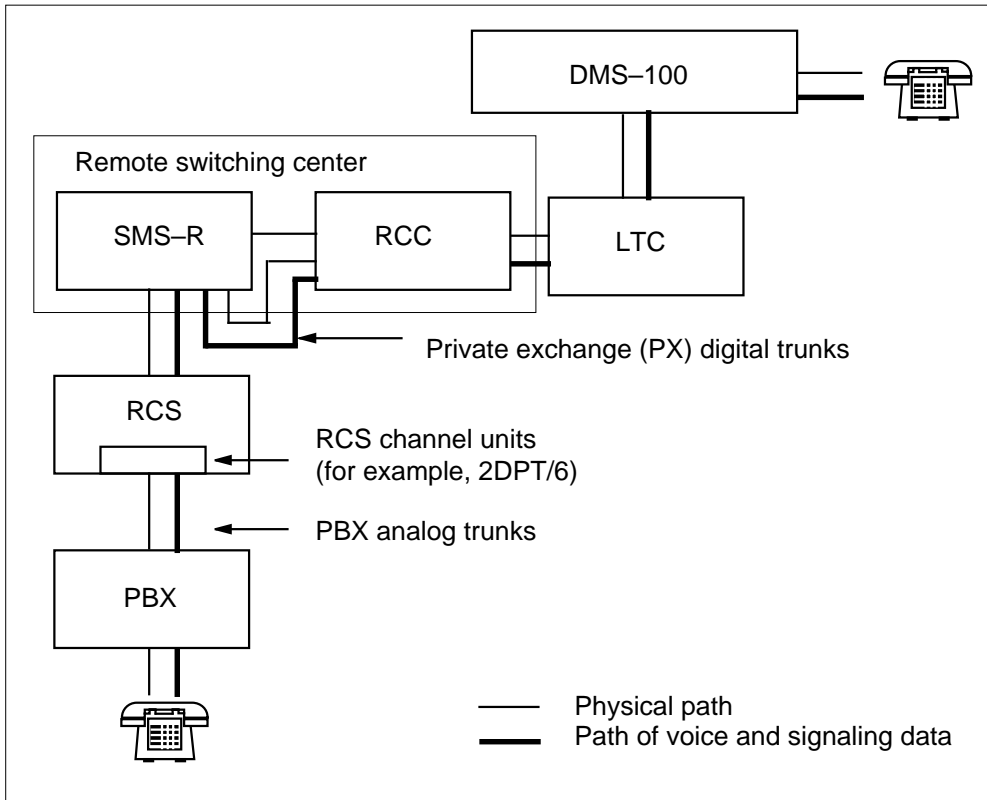
Figure 5-4 DDS hairpin connection on an SMS-R/RCS subsystem



The major difference between DDS hairpin connections and other special-service connections is that A- and B-bits are not inserted into the information path for the DDS hairpin connection. This is because DDS protocol uses the same bits as A and B signaling bits. The DDS protocol bit occupies position one in a byte.

**Direct inward dial (DID) PBX by hairpin** This feature uses special-services channel units in an RCS, a hairpin connection, and a DS-1 link from an SMS-R to a RCC or other piece of telephone equipment, as shown in the following DID PBX configuration figure.

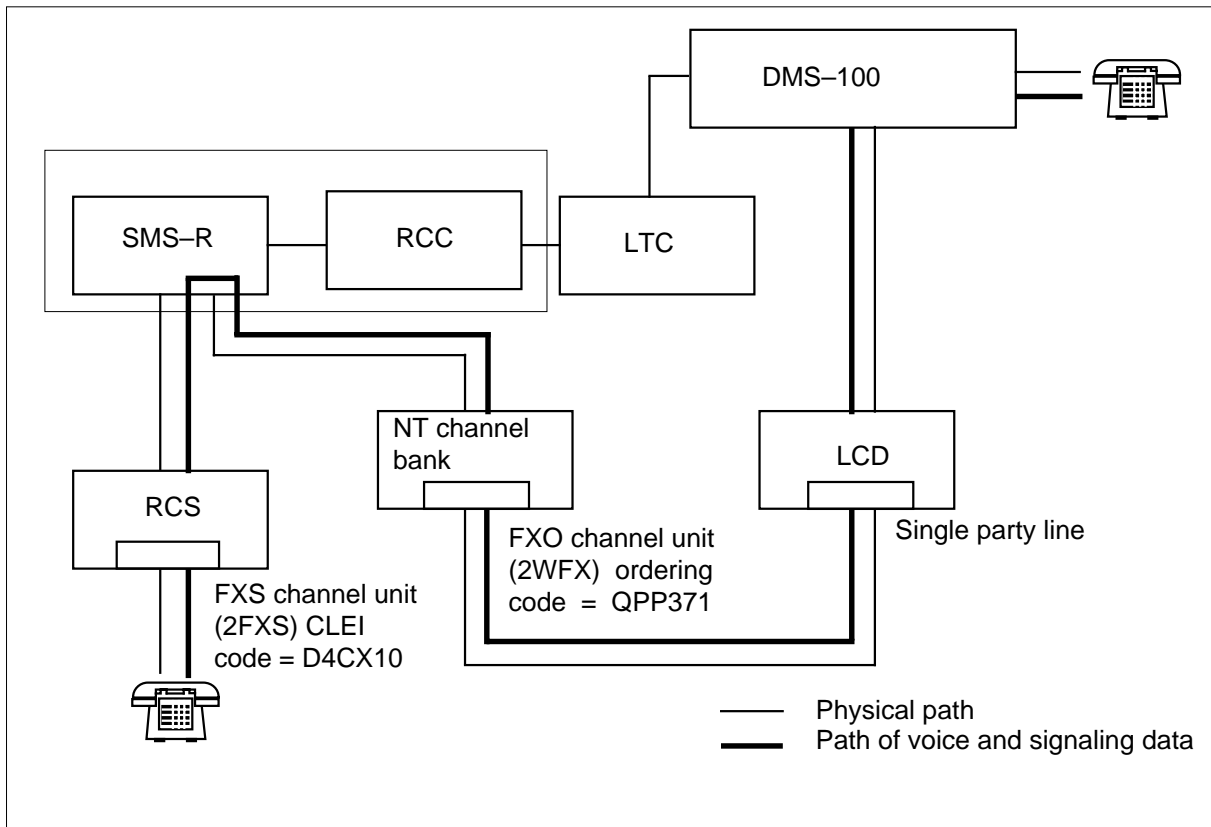
Figure 5-5 DID PBX configuration example



**Foreign exchange service** Special services supports foreign exchange service, enabling a subscriber to be served by a distant or foreign central office rather than by a nearby central office. Calls to other subscribers in the distant exchange area are then treated as local calls rather than toll calls.

As shown in the following figure, foreign exchange service uses special services foreign exchange station (FXS) channel units in an RCS, a hairpin connection, and foreign exchange office (FXO) channel units in a channel bank.

Figure 5-6 Foreign exchange service



**Integrated local specials** The special plain old telephone service (SPOTS) channel unit (S9CD271), besides supporting POTS, also supports special services such as the following:

- INWATS
- OUTWATS
- TWX
- PBX

The SPOTS channel unit is configured in loop or ground start mode. When SPOTS channel units are configured in loop start, they do not support PBX because PBX lines require ground-start signaling and ground-start mode.

Ground-start lines differ from loop-start lines in that loop-start (tip and ring) is handled differently to signal an off-hook. Also, ground-start off-hooks are acknowledged; loop-start off-hooks are not.

The SPOTS channel unit has the following characteristics:

- two voice-frequency, two-wire channels associated with each channel unit
- mechanized loop testing accessibility
- no gain or frequency setting
- required special service unit (SSU) configured in its associated RCS
- single-party 20 Hz ringing (-R ringing)

Refer to manufacturer's documentation for more information.

A SPOTS channel unit in the SMS-R/RCS subsystem has the following limitations:

- A channel assigned for both loop- and ground-start configurations. At least one DS-0 channel must be free for nondedicated channel units, if they exist on the RCS.

*Note:* Mode I does not have this limitation. Since four DS-1 links connect an RCS to an SMS-R, a DS-0 channel exists for every circuit.

- Using a SPOTS card in Mode III is not recommended because a Mode III RCS multiplexes 48 circuits onto two DS-1 links. Channel units on a Mode III RCS should have a single circuit. The SPOTS channel unit has two circuits, loop and ground. The circuit not used cannot be disabled.

*Note:* Although the S9CD271 SPOTS channel unit is not recommended for use in a Mode III RCS, it is allowed. However, only even-numbered circuits are assigned in Mode III.

- The SPOTS channel unit does not provide for tip-ring reversal (a signal used for many switches to indicate a toll call to the originating party). For this reason, the SPOTS channel unit may be restricted to nontoll calls when connected to a PBX or other equipment requiring tip-ring reversal.

The SPOTS channel unit is tested the same as a single-party line. The following tests on the SPOTS channel unit are supported:

- off-hook detection
- on-hook detection
- echo return loss
- single party ringing
- carrier channel loss
- idle channel noise

## Preparing to datafill SMS-R

### PCL—New software delivery vehicle

After BCS 36, Northern Telecom will begin delivering Product Computing-Module Loads (PCL) instead of BCS releases or Universal Software Loads (USL).

A PCL consists of features selected from the development stream software product intended for a particular application in a particular market. The PCL contains the capabilities previously divided among many related NTX packages. An eight-digit ordering code replaces the NTX package codes.

In the following table are the ordering codes and Functional Group names required for the SMS-R, as well as a listing of the former NTX packages that are included in the Functional Group. These capabilities are associated with the SMS-R.

**Table 5-2 SMS-R ordering codes**

| Ordering code | Functional group name | Former NTX package codes                                                           |
|---------------|-----------------------|------------------------------------------------------------------------------------|
| BAS00016      | BAS SCM/SMS/SMU       | NTXA85AB—Subscriber Module<br>SLC-96/Remote<br><br>NTXA86AA—SMS-R Special Services |
| RES00001      | RES Access Management | NTXE38AB—SMS-R CLASS<br>CND/CNAMD                                                  |
| MDC00001      | MDC - MDC Minimum     | NTX100AA—Meridian Digital Centrex - Basic                                          |

### Tasks associated with datafilling the SMS-R/RCS system

This section describes the tasks associated with datafilling the SMS-R using the DMS table editor. The SMS-R tables fall into categories listed in the following datafill summary:

- test trunks, test lines, and service circuits in table CLLI
- SMS-R and remote concentrator SLC-96 (RCS) datafill in tables SITE, LTRCRINV, LTRCPINV, RCSINV, RCCINV, and LNINV
- nailed-up cross-connections for special services in table PSNAILUP
- call processing translations in the lines, trunks, screening, and routing tables: TRKGRP, TRKSGRP, TRKMEM, LINEATTR, HUNTGRP, LENLINES, LENFEAT, HUNTMEM, DNROUTE, and HNPACONT
- system alarms in tables ALMSCGRP, ALMSDGRP, ALMSD, and ALMSC

- scan and signal distribution points in tables SCGRP and SDGRP
- metallic test access assignments in tables MTAMDRVE, MTAVERT, and MTAHORIZ
- CLASS and other optional feature applications datafilled in tables RCCINV, OFCOPT, RESOFC, SOFTKEY, TEXTPHRS, TEXTLOG, and RESFEAT

### **Protection lines**

Protection switching is a DMS-100 Family backup feature that ensures continued communication between an SMS-R and RCS if a DS-1 line connecting the two fails. Each RCS has from one to four primary lines, depending on the modes of its shelf groups, and at most one protection line.

### **Special services nailed-up cross-connections**

Special services include telecommunications services other than POTS, coin, and simple business services. These are nonsupervised, locally switched, special services supported by special-service cards in the RCS.

To support applications requiring special-service cards, a nailed-up cross-connection (hairpin connection) is set up and maintained through software table PSNAILUP. This is a peripheral-side (P-side) cross-connection. Information flows from an RCS into the SMS-R.

From the SMS-R, it is switched to a DS-1 line leading to a second RCS or other piece of digital equipment. The information is not switched through the network. The A and B signaling bits are looped around transparently; they are not processed. The DMS-100 Family system supports only single, two-way cross-connections.

When setting up a nailed-up cross-connection, the switch operator must enter information identifying both ends of the connection. This is done by indicating the type of peripheral where the end connects. For special services lines, the peripheral type is RCS.

### **Controlling RCS modes**

The mode of operation of each shelf group in the RCS is set up and maintained through software table RCSINV. The MODE field, a subfield of fields ABINFO and CDINFO, is datafilled as MODE1, MODE2, or MODE3. The RCS supports a mixed mode of operation. Each shelf group operates independently in one of the three modes. Refer to the appendix for procedures to convert an RCS from Mode I to Mode II.

### **Static datalog tracking**

Changes made to tables RCSINV, LTCRINV, and LTCRPINV are tracked by tuple change (TUPC) logs. These logs are TUPC100, TUPC101, TUPC102,

and TUPC103. Since these logs indicate datafill changes, they provide a starting point for recreating, debugging, and solving field problems.

This feature is helpful since the symptoms available at time-of-service degradation are not always sufficient to diagnose the problem occurring in the field.

### **When to update static data**

Static data for RCS implements two static data tables specific to the SMS-R: SMX\_RT and Remote\_Parm.

Table SMX\_RT, which cannot be manipulated by operating company personnel, contains configuration information about RCS terminals and includes the following data:

- alarm control unit type
- status of the PCM looping test in Mode II
- node number
- SMS-R P-side port where the protection line attaches
- shelf group modes of operation
- SMS-R P-side port numbers where DS-1 lines connecting an SMS-R and an RCS attach

Table Remote\_Parm contains line circuit information, including card codes, which are entered in table LNINV for line cards.

Central control sends static data to the SMS-R peripheral processor (PP) when the PP is initialized. Initialization occurs when an SMS-R is returned to service (RTS), loaded with software (LOADPM), and reset (PMRESET). Static data is also sent when operating company personnel update fields in tables LTCRPINV, RCSINV, or LTCRINV.

When the fields in these tables are updated, the corresponding information is usually updated in tables SMX\_RT and Remote\_Parm. This information is downloaded from central control to the SMS-R PP when the SMS-R is in service.

Changing the ABINFO, CDINFO, or CSPMNO fields in table RCSINV disables call processing for the associated RCS.

**Note:** Changing the CSPMNO in table RCSINV associates the RCS with another SMS-R. When the ABINFO and CDINFO fields are changed, no change to the SMS-R associated with the RCS occurs.

**Dynamic static data update**

Dynamic static data update, also known as dynamic PM reconfiguration, provides the capability for in-service line trunk controllers (LTC) and remote cluster controllers (RCC) to add, delete, and reconfigure the SMS-R, the SMS-R P-side and C-side links, and the RCS without updating static data of the affected in-service peripheral through an RTS.

With dynamic static data update, changes to an RCS are made with the SMS-R in service. Modifications to SMS-R P-side links and C-side speech links are made with the SMS-R in-service. However, changes to an SMS-R message links are made with the SMS-R manually busy.

*Note 1:* The host LTC and RCC remain in-service for all static data update operations on the SMS-R and its RCSs. This is particularly important if the RCC hosts additional nodes such as line concentrating modules (LCM) or other SMS-Rs.

*Note 2:* Since call processing uses the configuration data, any dynamic changes to the data may cause calls to be cleared.

This feature eliminates the need to busy the units, load static data, and RTS the host nodes (LTC, RCC, SMS-R) when a node is added, deleted, or reconfigured.

The following restrictions apply to the dynamic static data update feature:

- Static data updates occur only for in-service nodes without maintenance actions in progress. If an update occurs while an affected node is performing maintenance, a static data mismatch is created. This is cleared by busying the unit(s), loading static data, and performing an RTS of the unit(s).
- All current table control restrictions apply to the reconfiguration of nodes and links.
- The Dynamic Static Data Update feature is limited to supporting the in-service updates of configuration data resulting from the inventory table control modifications identified in the following table.

**Table 5-3 control modifications supported by dynamic static data update**

| table    | Changes supported by feature                                                                             |
|----------|----------------------------------------------------------------------------------------------------------|
| LTCRINV  | Changing C-side links                                                                                    |
| LTCRPINV | Changing P-side links                                                                                    |
| RCSINV   | Adding a tuple, deleting a tuple, changing C-side node, changing C-side links, and changing ringing data |



---

## Basic Call Processing

---

### Functional group

BAS00016

### Feature package

NTXA85AB Subscriber Carrier Module SLC-96/Remote

### Release applicability

BCS34 and later versions

### Requirements

To operate, Basic Call Processing requires the following feature packages:

- NTX000AA Bilge
- NTX001AA Common Basic
- NTX270AA New Peripheral Maintenance Package
- NTX901AA Local Features I
- NTX145AA Remote Switching Center
- NTX269AA Universal Tone Receiver (Domestic)
- NTX398AA SCM-100S

### Description

The NTXA85AB feature package provides a direct digital interface between the Remote Switching Center (RSC) and TR-008-compliance digital loop carriers. An example of a digital loop carrier is the SLC-96.

### Operation

The Subscriber Carrier Module-100S Remote (SMS-R) is a peripheral module (PM). The modules for the SMSR are line group controller (LGC) and line trunk controller (LTC) architecture. The SMS-R improves the ability of the DMS-100 Family RSC. The SMS-R allows direct through digital connection between an RSC and the remote carrier SLC-96 (RCS). The RSC provides access to host DMS-100 central office services for a maximum of 11,500 lines at remote locations.

### Translations table flow

This package does not change standard translations data flow.

### Limits

Basic Call Processing does not have limits.

## Basic Call Processing (continued)

---

### Interactions

Basic Call Processing does not have functionality interactions.

### Activation/deactivation by the end user

Basic Call Processing does not require activation or deactivation by the end user.

### Billing

Basic Call Processing does not affect billing.

### Station Message Detail Recording

Basic Call Processing does not affect Station Message Detail Recording.

### Datafilling office parameters

Basic Call Processing does not affect office parameters.

### Datafill sequence

The following table lists the tables that require datafill to start Basic Call Processing. The tables appear in the correct entry order.

*Note:* When an inhibit lead is in use, enter tables SCGRP and SDGRP before table RCSINV.

#### Datafill requirements for Basic Call Processing (Sheet 1 of 4)

| Table                                                                                                                     | Purpose of table                                                                                                                                                                                                                                                   |
|---------------------------------------------------------------------------------------------------------------------------|--------------------------------------------------------------------------------------------------------------------------------------------------------------------------------------------------------------------------------------------------------------------|
| CLLI                                                                                                                      | Common Language Location Identifier. Table CLLI identifies the maintenance and test trunks that the SMS-R/RCS system uses.                                                                                                                                         |
| SITE                                                                                                                      | Site. Table SITE allows the DMS to recognize the remote equipment that ties to the host.                                                                                                                                                                           |
| CARRMTC                                                                                                                   | Carrier Maintenance Control. Table CARRMTC allows the DMS switch administration to enter maintenance control information. The administrator can enter this information is peripherals, out-of-service limits for alarms, and system return-to-service occurrences. |
| PMLOADS                                                                                                                   | Peripheral Module Loads. Table PMLOADS stores a load map between the load names and the devices where the loads reside. The load map allows auto load to locate load files. The auto lead does not require the action of operating company personnel.              |
| <i>Note:</i> Enter lines in this table through SERVORD. For additional information about this function, refer to SERVORD. |                                                                                                                                                                                                                                                                    |

**Basic Call Processing** (continued)**Datafill requirements for Basic Call Processing (Sheet 2 of 4)**

| <b>Table</b>                                                                                                              | <b>Purpose of table</b>                                                                                                                                                                                                                                                                                |
|---------------------------------------------------------------------------------------------------------------------------|--------------------------------------------------------------------------------------------------------------------------------------------------------------------------------------------------------------------------------------------------------------------------------------------------------|
| LTCRINV                                                                                                                   | Line Trunk Controller Remote Inventory. Table LTCRINV inventories different PM types. This inventory includes the SMS-R and excludes P-side link assignments.                                                                                                                                          |
| LTCRPINV                                                                                                                  | Line Trunk Controller Remote P-Side Link Inventory. Table LTCRPINV identifies the SMS-R module type and number, and the port name of the P-side links.                                                                                                                                                 |
| RCSINV                                                                                                                    | Remote Concentrator Subscriber Inventory. Table RCSINV identifies the location of the RCS and C-side links. This table identifies the SMS-R where the links connect and the mode of operation of the RCS shelf groups. This table identifies protection switching details, and additional information. |
| TMINV                                                                                                                     | Trunk Module Inventory. Table TMINV identifies trunk modules that contain test circuits that terminate test pairs that connect to RCS lines.                                                                                                                                                           |
| TRKGRP                                                                                                                    | Trunk Group. Table TRKGRP identifies test circuits associated with maintenance and test trunks.                                                                                                                                                                                                        |
| TRKSGRP                                                                                                                   | Trunk Subgroup. Table TRKSGRP lists auxiliary information for each subgroup assigned to a trunk group table TRKGRP lists.                                                                                                                                                                              |
| TRKMEM                                                                                                                    | Trunk Member. Table TRKMEM identifies the circuits associated with test equipment that tests lines and trunks.                                                                                                                                                                                         |
| ALMSCGRP                                                                                                                  | Alarm Scan Group. Table ALMSCGRP records circuit equipment, location, and type of card. This table serves as a head table for the correct scan points.                                                                                                                                                 |
| ALMSDGRP                                                                                                                  | Alarm Scan Group. Table ALMSDGRP records the circuit equipment, location, and type of card. This table serves as a head table for the correct signal distribution (SD) points.                                                                                                                         |
| ALMSD                                                                                                                     | Alarm Signal Distributor Point. Table ALMSD identifies the function performed by each assigned SD point in the alarm SD groups.                                                                                                                                                                        |
| ALMSC                                                                                                                     | Alarm Scan. Table ALMSC identifies the functions that each assigned scan point in the alarm scan groups performs.                                                                                                                                                                                      |
| SCGRP                                                                                                                     | Scan Group. Table SCGRP lists the product engineering code (PEC). This table lists the location at the host or remote switching units for scan groups for use as scan points for line features.                                                                                                        |
| SDGRP                                                                                                                     | Signal Distributor Group. Table SDGRP lists the PEC. This table lists the location at the host or remote switching units for SD groups. The system reserves these groups for use as SD points for line features.                                                                                       |
| <b>Note:</b> Enter lines in this table through SERVORD. For additional information about this function, refer to SERVORD. |                                                                                                                                                                                                                                                                                                        |

## Basic Call Processing (continued)

### Datafill requirements for Basic Call Processing (Sheet 3 of 4)

| Table                                                                                                                     | Purpose of table                                                                                                                                                                                                                                                                                                                                                                                                     |
|---------------------------------------------------------------------------------------------------------------------------|----------------------------------------------------------------------------------------------------------------------------------------------------------------------------------------------------------------------------------------------------------------------------------------------------------------------------------------------------------------------------------------------------------------------|
| LINEATTR                                                                                                                  | Line Attributes. Table LINEATTR assigns line attributes to normal lines in table LENLINES and Meridian stations. This table assigns line attributes to attendant consoles in MDC translations tables.                                                                                                                                                                                                                |
| LNINV (Note)                                                                                                              | Line Circuit Inventory. Table LNINV retains an inventory of subscriber lines and associated line cards for RCS modules.                                                                                                                                                                                                                                                                                              |
| HUNTGRP (Note)                                                                                                            | Hunt Group. Table HUNTGRP stores data for hunt groups assigned in the switching unit.                                                                                                                                                                                                                                                                                                                                |
| LENLINES (Note)                                                                                                           | Line Assignment. Table LENLINES lists the following data for each line: <ul style="list-style-type: none"> <li>• site name, if the line is remote</li> <li>• line equipment number (LEN)</li> <li>• party where the system assigns directory number (DN).</li> <li>• ringing code assigned to the DN</li> <li>• DN</li> <li>• signal type</li> <li>• index into table LINEATTR</li> <li>• list of options</li> </ul> |
| LENFEAT (Note)                                                                                                            | Line Feature. Table LENFEAT lists features the system assigned to a specified line in table LENLINES.                                                                                                                                                                                                                                                                                                                |
| HUNTMEM (Note)                                                                                                            | Hunt Group Member. Table HUNTMEM lists members assigned to hunt groups that table HUNTGRP lists.                                                                                                                                                                                                                                                                                                                     |
| DNROUTE                                                                                                                   | Directory Number Route. Table DNROUTE stores DNs not associated with a LEN. The DNs are the result of operating company input.                                                                                                                                                                                                                                                                                       |
| HNPACONT                                                                                                                  | List of HNPA Code Subtables. Table HNPACONT lists the home numbering plan area (HNPA) subtables.                                                                                                                                                                                                                                                                                                                     |
| MTAMDRVE                                                                                                                  | Metallic Test Access Minibar Driver. Table MTAMDRVE specifies the location and the type of minibar driver assigned to the minibar switch.                                                                                                                                                                                                                                                                            |
| <b>Note:</b> Enter lines in this table through SERVORD. For additional information about this function, refer to SERVORD. |                                                                                                                                                                                                                                                                                                                                                                                                                      |

## Basic Call Processing (continued)

### Datafill requirements for Basic Call Processing (Sheet 4 of 4)

| Table                                                                                                                     | Purpose of table                                                                                                                                              |
|---------------------------------------------------------------------------------------------------------------------------|---------------------------------------------------------------------------------------------------------------------------------------------------------------|
| MTAVERT                                                                                                                   | Metallic Test Access Vertical Connection. Table MTAVERT identifies the vertical connectivity to the metallic test access (MTA) matrix.                        |
| MTAHORIZ                                                                                                                  | Metallic Test Access Horizontal Connection. Table MTAHORIZ lists the assignment to a horizontal and horizontal group of metallic test access minibars (MTAM). |
| <b>Note:</b> Enter lines in this table through SERVORD. For additional information about this function, refer to SERVORD. |                                                                                                                                                               |

### Datafilling table CLLI

Datafill specific to Basic Call Processing for table CLLI appear in the following table. Fields that apply directly to Basic Call Processing appear. For a description of the other fields, refer to the data schema section of this document.

The common language location identifier (CLLI) codes identifies the far end of each announcement, tone and trunk group. The CLLI codes identify test trunk in a country milliwatt test lines and service circuit. This table identifies the maintenance and test trunks that the SMS-R/RCS system uses.

### Datafilling table CLLI (Sheet 1 of 2)

| Field                                                                                                            | Subfield or refinement | Entry                                           | Description                                                                                                                                                                                                                                                                                 |
|------------------------------------------------------------------------------------------------------------------|------------------------|-------------------------------------------------|---------------------------------------------------------------------------------------------------------------------------------------------------------------------------------------------------------------------------------------------------------------------------------------------|
| CLLI                                                                                                             |                        | refer to subfields (a maximum of 16 characters) | Common language location identifier. This field is a 16-character field. The field identifies the far end of each announcement, tone, and trunk group, test trunk, national milliwatt test lines, and service circuit. The recommended subfields are PLACE, PROV, BLDG, TRAFUNIT, and SUFX. |
|                                                                                                                  | PLACE                  | alphanumeric                                    | Place. This four-character code identifies the name of the city or location at the far end of each group.                                                                                                                                                                                   |
|                                                                                                                  | PROV                   | alphanumeric                                    | Province or state. This two-character code identifies the province or state at the far end of the trunk group.                                                                                                                                                                              |
| <b>Note 1:</b> The SIZE field in table DATASIZE allocates memory for the entry with field DATSKEY equal to CLLI. |                        |                                                 |                                                                                                                                                                                                                                                                                             |
| <b>Note 2:</b> The maximum number of CLLI codes is 8192.                                                         |                        |                                                 |                                                                                                                                                                                                                                                                                             |

**Basic Call Processing** (continued)

**Datafilling table CLLI (Sheet 2 of 2)**

| Field                                                                                                                                                                                   | Subfield or refinement | Entry                                   | Description                                                                                                                                                                                                                                      |
|-----------------------------------------------------------------------------------------------------------------------------------------------------------------------------------------|------------------------|-----------------------------------------|--------------------------------------------------------------------------------------------------------------------------------------------------------------------------------------------------------------------------------------------------|
|                                                                                                                                                                                         | BLDG                   | alphanumeric                            | Bldg. This two-character code identifies the building number at the far end of the trunk group.                                                                                                                                                  |
|                                                                                                                                                                                         | TRAFUNIT               | alphanumeric                            | Traffic unit. This three-character code identifies the destination of the traffic unit at the far end of the trunk group.                                                                                                                        |
|                                                                                                                                                                                         | SUFIX                  | alphanumeric                            | Suffix. This one-character code identifies trunk groups that terminate at the same CLLI location.                                                                                                                                                |
| ADNUM                                                                                                                                                                                   |                        | numeric                                 | Administrative trunk group number. Enter a number from 0 through a number that is one less than the size of table CLLI. The size of table CLLI appears in table DATASIZE. The value must be not the same as the other values.                    |
| TRKGRPSIZ                                                                                                                                                                               |                        | 0 to 2047                               | Trunk group size. This four-character field is equal to the maximum quantity of trunk members that the system assigns to the trunk group.                                                                                                        |
| ADMININF                                                                                                                                                                                |                        | alphanumeric (maximum of 32 characters) | Administrative information. The operating company uses this 32-character field to record administrative information. The switching unit does not use the information in this field. The recommended subfields are TRAFCLS, OFFCLS, and TRKGRTYP. |
|                                                                                                                                                                                         | TRAFCLS                | alphanumeric                            | Trunk group traffic class. This field is optional. This field is for administrative purposes.                                                                                                                                                    |
|                                                                                                                                                                                         | OFFCLS                 | alphanumeric                            | Office class. This field is optional. This field is for administrative purposes.                                                                                                                                                                 |
|                                                                                                                                                                                         | TRKGRTYP               | alphanumeric                            | Trunk group type. This field is optional. This field is for administrative purposes.                                                                                                                                                             |
| <p><b>Note 1:</b> The SIZE field in table DATASIZE allocates memory for the entry with field DATSKEY equal to CLLI.</p> <p><b>Note 2:</b> The maximum number of CLLI codes is 8192.</p> |                        |                                         |                                                                                                                                                                                                                                                  |

**Datafill example for table CLLI**

Sample datafill for table CLLI appear in the following example.

## Basic Call Processing (continued)

### MAP example for table CLLI

| Table: CLLI |       |          |                      |
|-------------|-------|----------|----------------------|
| CLLI        | ADNUM | TRKGRSIZ | ADMININF             |
| MTADRIVER   | 250   | 32       | METALLIC_TEST_DRIVER |
| MONTALK     | 254   | 32       | VERIFICATION         |
| MJACK       | 257   | 256      | METALLIC_JACK        |
| LTU         | 259   | 32       | LINE_TEST_UNIT       |

### Datafilling table SITE

Datafill specific to Basic Call Processing for table SITE appear in the following table. Fields that apply directly to Basic Call Processing appear. For a description of the other fields, refer to the data schema section of this document.

Table SITE contains data for the switching unit and for the remote locations that attach to the unit. This data in table SITE allows the DMS system to recognize the equipment. Enter data in table SITE before a line equipment number (LEN) is assigned and a PM is entered.

The first entry in the table SITE must be HOST for the host switching unit. The operating company defines the site names for the remote locations.

*Note:* The system allocates memory for a maximum of 32 sites.

### Datafilling table SITE (Sheet 1 of 2)

| Field                                                               | Subfield or refinement | Entry                             | Description                                                                                                                                                                                                                                                                                          |
|---------------------------------------------------------------------|------------------------|-----------------------------------|------------------------------------------------------------------------------------------------------------------------------------------------------------------------------------------------------------------------------------------------------------------------------------------------------|
| SITE                                                                |                        | alphanumeric (1 to 16 characters) | Site name. Enter the site name assigned to the remote switching unit. The first character must be alphabetical. Site names can be a maximum of four characters in length. Do not use PM type names for site names.<br><br><i>Note:</i> The first entry in this field is for the host switching unit. |
| LTDSN                                                               |                        | 00 to 99                          | The LEN test desk site number. Enter a two-digit number to dial the site that appears under field NAME.                                                                                                                                                                                              |
| <i>Note:</i> The system allocates memory for a maximum of 32 sites. |                        |                                   |                                                                                                                                                                                                                                                                                                      |

## Basic Call Processing (continued)

Datafilling table SITE (Sheet 2 of 2)

| Field    | Subfield or refinement | Entry                 | Description                                                                                                                                                                                                                                 |
|----------|------------------------|-----------------------|---------------------------------------------------------------------------------------------------------------------------------------------------------------------------------------------------------------------------------------------|
| MODCOUNT |                        | 0                     | Module count. Enter 0. The system updates the value to reflect the number of LMs in tables LMINV and LCMINV.                                                                                                                                |
| OPVRCLLI |                        | VER90 or alphanumeric | Operator verification CLLI. Enter the CLLI assigned to the operator verification trunk group at the remote location.                                                                                                                        |
| ALMDATA  |                        | refer to subfields    | Alarm data. This field is for remote locations only. This field contains subfields ALMTYPE, TMTYPE, TMNO, TMCKTNO, POINT.                                                                                                                   |
|          | ALMTYPE                | CR, MJ, MN, or NA     | Alarm type. If the entry is for a remote location, enter the alarm type. Critical (CR), major (MJ), or minor (MN). If the entry is for the host switching unit, enter NA.                                                                   |
|          | TMTYPE                 | RMM, RSM or blank     | Trunk module type. The entry can be for a remote location. Enter the trunk module type, RSM or RMM. The TMTYPE is the location of the miscellaneous SD point assigned to the alarm.                                                         |
|          | TMNO                   | 0 to 2047             | Trunk module number. The entry can be for a remote location. Enter the number assigned to the RSM on which the different SD point assigned to the alarm belongs.                                                                            |
|          | TMCKTNO                | 0 to 29 or blank      | Trunk module circuit number. The entry can be for a remote location. Enter the TM circuit number of the RSM or RMM on which the different SD point assigned to the alarm belongs. If the entry is for the host switching unit, leave blank. |
|          | POINT                  | 0 to 7 or blank       | Point. If the entry is for a remote location, enter the SD point number that belongs to the alarm. If the entry is for the host switching unit, leave blank.                                                                                |

**Note:** The system allocates memory for a maximum of 32 sites.

### Datafill example for table SITE

Sample datafill for table SITE appear in the following example.



---

**Basic Call Processing** (continued)

---

**MAP example for table SITE**

| Table: SITE |       |          |          |     |     |    |    |       |  |    |
|-------------|-------|----------|----------|-----|-----|----|----|-------|--|----|
| NAME        | LTDSN | MODCOUNT | OPVRCLLI | ALM | TM  | TM | TM | POINT |  |    |
| HOST        | 00    | 0        | VER90    |     |     |    |    |       |  | \$ |
| CARY        | 02    | 2        | RMMVER90 | CR  | RSM | 0  | 4  | 0     |  | +  |
|             |       |          |          | MJ  | RSM | 0  | 4  | 1     |  | +  |
|             |       |          |          | MN  | RSM | 0  | 4  | 2     |  | \$ |

**Datafilling table CARRMTC**

Datafill specific to Basic Call Processing for table CARRMTC appear in the following table. Only fields that apply to Basic Call Processing appear. For a description of the other fields, refer to the data schema section of this document.

Table CARRMTC allows the DMS switch administrator to enter maintenance control information. The administrator enters this information in peripherals, out-of-service (OOS) limits for alarms, and system return to service (RTS) occurrences.

A carrier maintains communication on specified links. These links connect DMS peripherals to channel banks, DMS peripherals to remote DMS peripherals, or remote DMS peripherals to remote DMS peripherals.

From 16 to 20 entries are available for each type of peripheral that can provide carrier links in the switch. Table LTCRPINV contains a selection of entries for each carrier.

The system performs following checks between table CARRMTC and table LTCRPINV:

- When you enter a carrier index (CARRIDX) in table LTCRPINV, table CARRMTC must contain an entry for the PM type. In this example, the entry is SMS-R.
- When you delete an entry from table CARRMTC, carriers in table LTCRPINV cannot reference that entry. In other conditions, the system rejects the DELETE command.
- When a current entry is changed in table CARRMTC, the system checks table LTCRPINV to determine if in-service (InSv) carriers reference the

## Basic Call Processing (continued)

entry. If InSv carriers reference the entry, the system rejects change command and displays a list of InSv carriers.

**Datafilling table CARRMTC (Sheet 1 of 4)**

| Field                                                                                                                                                                                                                                                                                                                                                                                                                                                                                                                                                                                                                                                                                                               | Subfield or refinement | Entry                                     | Description                                                                                                                                                                          |
|---------------------------------------------------------------------------------------------------------------------------------------------------------------------------------------------------------------------------------------------------------------------------------------------------------------------------------------------------------------------------------------------------------------------------------------------------------------------------------------------------------------------------------------------------------------------------------------------------------------------------------------------------------------------------------------------------------------------|------------------------|-------------------------------------------|--------------------------------------------------------------------------------------------------------------------------------------------------------------------------------------|
| CSPMTYPE                                                                                                                                                                                                                                                                                                                                                                                                                                                                                                                                                                                                                                                                                                            |                        | SMSR                                      | The C-side node PM type. Enter the PM type of the node on the C-side of the carrier link (in this example, SMS-R).                                                                   |
| TMPLTNM                                                                                                                                                                                                                                                                                                                                                                                                                                                                                                                                                                                                                                                                                                             |                        | alphanumeric (a maximum of 16 characters) | Template name. Enter the template name for the PM. This entry also appears in field CARRIDX of table LTCRPINV. The default value is DEFAULT. Examples are PRIMARY and PROTECTION.    |
| RTSML                                                                                                                                                                                                                                                                                                                                                                                                                                                                                                                                                                                                                                                                                                               |                        | 0 to 255                                  | RTS maintenance limit. Enter the number of times in the audit interval the system returns a carrier to service before the system issues a warning. Value 255 disables this feature.  |
| RTSOL                                                                                                                                                                                                                                                                                                                                                                                                                                                                                                                                                                                                                                                                                                               |                        | 0 to 255                                  | RTS OOS limit. Enter the number of times in the audit interval the system returns a carrier to service before the carrier goes OOS. Value 255 disables this feature.                 |
| ATTR                                                                                                                                                                                                                                                                                                                                                                                                                                                                                                                                                                                                                                                                                                                |                        | refer to subfield                         | Attribute. Contains subfield SELECTOR                                                                                                                                                |
|                                                                                                                                                                                                                                                                                                                                                                                                                                                                                                                                                                                                                                                                                                                     | SELECTOR               | DS1                                       | Selector. Enter carrier type DS1. If the entry for subfield SELECTOR is DS1, enter subfield CARD.                                                                                    |
|                                                                                                                                                                                                                                                                                                                                                                                                                                                                                                                                                                                                                                                                                                                     | CARD                   | 6X85AA or 6X85AB                          | Card. Enter the PEC of the DS-1 interface card. For the SMS-R, enter 6X85AA or 6X85AB. If the entry for subfield CARD is 6X85AA or 6X85AB, the following subfields require datafill. |
| <p><b>Note 1:</b> The DMS system adds the first tuple for SMS-R to table CARRMTC during initial program load (IPL) or first restart after IPL. The name of the entry is index 0. The name of the entry contains the value DEFAULT in the TMPLTNM field and default values for the other fields. Do not delete this tuple. The system changes fields ES, SES, and thresholds for frame and slip losses.</p> <p><b>Note 2:</b> Add tuples other than the default tuple before the tuples are referenced in table LTCRPINV. Delete these tuples if DS-1 carriers do not associate with these DS-1 carriers.</p> <p><b>Note 3:</b> Change tuples in table CARRMTC if the associated DS-1 carriers are ManB or OFFL.</p> |                        |                                           |                                                                                                                                                                                      |

**Basic Call Processing** (continued)

Datafilling table CARRMTC (Sheet 2 of 4)

| Field                                                                                                                                                                                                                                                                                                                                                                                                                                                                                                                                                                                                                                                                                                                | Subfield or refinement | Entry           | Description                                                                                                                                                                                                                                                                                                                                                                                                                |
|----------------------------------------------------------------------------------------------------------------------------------------------------------------------------------------------------------------------------------------------------------------------------------------------------------------------------------------------------------------------------------------------------------------------------------------------------------------------------------------------------------------------------------------------------------------------------------------------------------------------------------------------------------------------------------------------------------------------|------------------------|-----------------|----------------------------------------------------------------------------------------------------------------------------------------------------------------------------------------------------------------------------------------------------------------------------------------------------------------------------------------------------------------------------------------------------------------------------|
| ATTR<br>(continued)                                                                                                                                                                                                                                                                                                                                                                                                                                                                                                                                                                                                                                                                                                  | VOICELAW               | A_LAW or MU_LAW | Voice law. Enter the voice law that the carrier uses. The A_LAW uses for international switches and MU_LAW for North American switches.                                                                                                                                                                                                                                                                                    |
|                                                                                                                                                                                                                                                                                                                                                                                                                                                                                                                                                                                                                                                                                                                      | FF                     | SF              | Frame formula. Enter SF for standard frame. The SMS-R/RCS subsystem uses the 12-frame formula, 125 $\mu$ s per frame.                                                                                                                                                                                                                                                                                                      |
|                                                                                                                                                                                                                                                                                                                                                                                                                                                                                                                                                                                                                                                                                                                      | ZLG                    | ZCS             | Zero logic. Enter ZCS for zero code suppression.                                                                                                                                                                                                                                                                                                                                                                           |
|                                                                                                                                                                                                                                                                                                                                                                                                                                                                                                                                                                                                                                                                                                                      | BERB                   | BPV or CRC      | Bit error rate base. Enter BPV for bipolar violation. Enter CRC for cyclic redundancy code.                                                                                                                                                                                                                                                                                                                                |
|                                                                                                                                                                                                                                                                                                                                                                                                                                                                                                                                                                                                                                                                                                                      | DLK                    | NILDL           | Data link. Enter NILDL for no data link.                                                                                                                                                                                                                                                                                                                                                                                   |
|                                                                                                                                                                                                                                                                                                                                                                                                                                                                                                                                                                                                                                                                                                                      | IAT                    | Y or N          | Inhibit alarm transmit. Enter Y for the IAT field to inhibit yellow alarms. The RCS modules in any mode do not support yellow-alarm reception. The SMS-R yellow alarm transmits reception to the RCS when the SMS-R detects frame loss. Enter this field and disable the transmission of yellow alarms. If you do not set the IAT field correctly, the subscriber can hear a loud noise if the SMS-R detects a DS-1 fault. |
|                                                                                                                                                                                                                                                                                                                                                                                                                                                                                                                                                                                                                                                                                                                      | LCGAST                 | 1 to 9999       | Local carrier group alarm set threshold. Enter the threshold value in units of 10 ms. Primary links on an SMS-R range from 40 to 250 ms. Enter 80 when protection links are present. Enter 250 when the links are not present. The range for protection links is 100 to 250 ms. The recommended value is 250.                                                                                                              |
| <p><b>Note 1:</b> The DMS system adds the first tuple for SMS-R to table CARRMTC during initial program load (IPL) or first restart after IPL. The name of the entry is index 0. The name of the entry contains the value DEFAULT in the TEMPLTNM field and default values for the other fields. Do not delete this tuple. The system changes fields ES, SES, and thresholds for frame and slip losses.</p> <p><b>Note 2:</b> Add tuples other than the default tuple before the tuples are referenced in table LTCRPINV. Delete these tuples if DS-1 carriers do not associate with these DS-1 carriers.</p> <p><b>Note 3:</b> Change tuples in table CARRMTC if the associated DS-1 carriers are ManB or OFFL.</p> |                        |                 |                                                                                                                                                                                                                                                                                                                                                                                                                            |

## Basic Call Processing (continued)

Datafilling table CARRMTC (Sheet 3 of 4)

| Field                                                                                                                                                                                                                                                                                                                                                                                                                                                                                                                                                                                                                                                                                                                | Subfield or refinement | Entry     | Description                                                                                                                                                                                                                                                                                                                    |
|----------------------------------------------------------------------------------------------------------------------------------------------------------------------------------------------------------------------------------------------------------------------------------------------------------------------------------------------------------------------------------------------------------------------------------------------------------------------------------------------------------------------------------------------------------------------------------------------------------------------------------------------------------------------------------------------------------------------|------------------------|-----------|--------------------------------------------------------------------------------------------------------------------------------------------------------------------------------------------------------------------------------------------------------------------------------------------------------------------------------|
| ATTR<br>(continued)                                                                                                                                                                                                                                                                                                                                                                                                                                                                                                                                                                                                                                                                                                  | LCGACL                 | 1 to 9999 | Local carrier group alarm clear threshold. Enter the threshold value in units of 10 ms. Primary links on an SMS-R range from 100 to 1000 ms. Enter 200 when protection links are present. Enter 1000 when the protection links are not present. The range for protection links is 200 to 400 ms. The recommended value is 300. |
|                                                                                                                                                                                                                                                                                                                                                                                                                                                                                                                                                                                                                                                                                                                      | RCGAST                 | 1 to 9999 | Remote carrier group alarm set threshold. Enter the threshold value in units of 10 ms.                                                                                                                                                                                                                                         |
|                                                                                                                                                                                                                                                                                                                                                                                                                                                                                                                                                                                                                                                                                                                      | RCGACL                 | 1 to 9999 | Remote carrier group alarm clear threshold. Enter the threshold value in units of 10 ms.                                                                                                                                                                                                                                       |
|                                                                                                                                                                                                                                                                                                                                                                                                                                                                                                                                                                                                                                                                                                                      | AISST                  | 1 to 9999 | Alarm indication signal set threshold. Enter the threshold value in units of 10 ms.<br><br><b>Note:</b> The DS-1 lines connect the SMS-R and RCS. Alarm indication signals (AIS) do not have an application in this network. Use the default value for this field.                                                             |
|                                                                                                                                                                                                                                                                                                                                                                                                                                                                                                                                                                                                                                                                                                                      | AISCL                  | 1 to 9999 | Alarm indication signal clear threshold. Enter the threshold value in units of 10 ms.<br><br><b>Note:</b> The DS-1 lines connect the SMS-R and RCS. Alarm indication signals (AIS) do not have an application in this network. Use the default value for this field.                                                           |
|                                                                                                                                                                                                                                                                                                                                                                                                                                                                                                                                                                                                                                                                                                                      | BEROL                  | 3 to 6    | Bit error rate OOS limit. Enter the bit error rate OOS limit as the negative of the power of 10 (10E-n). For example, 3 represents a 1 in 1000 bit error rate.                                                                                                                                                                 |
| <p><b>Note 1:</b> The DMS system adds the first tuple for SMS-R to table CARRMTC during initial program load (IPL) or first restart after IPL. The name of the entry is index 0. The name of the entry contains the value DEFAULT in the TEMPLNM field and default values for the other fields. Do not delete this tuple. The system changes fields ES, SES, and thresholds for frame and slip losses.</p> <p><b>Note 2:</b> Add tuples other than the default tuple before the tuples are referenced in table LTCRPIINV. Delete these tuples if DS-1 carriers do not associate with these DS-1 carriers.</p> <p><b>Note 3:</b> Change tuples in table CARRMTC if the associated DS-1 carriers are ManB or OFFL.</p> |                        |           |                                                                                                                                                                                                                                                                                                                                |

**Basic Call Processing** (continued)**Datafilling table CARRMTC (Sheet 4 of 4)**

| Field                                                                                                                                                                                                                                                                                                                                                                                                                                                                                                                                                                                                                                                                                                               | Subfield or refinement | Entry     | Description                                                                                                                        |
|---------------------------------------------------------------------------------------------------------------------------------------------------------------------------------------------------------------------------------------------------------------------------------------------------------------------------------------------------------------------------------------------------------------------------------------------------------------------------------------------------------------------------------------------------------------------------------------------------------------------------------------------------------------------------------------------------------------------|------------------------|-----------|------------------------------------------------------------------------------------------------------------------------------------|
| ATTR<br>(continued)                                                                                                                                                                                                                                                                                                                                                                                                                                                                                                                                                                                                                                                                                                 | BERML                  | 4 to 7    | Bit error rate maintenance limit. Enter the bit error rate maintenance limit expressed as the negative of the power of 10 (10E-n). |
|                                                                                                                                                                                                                                                                                                                                                                                                                                                                                                                                                                                                                                                                                                                     | ES                     | 0 to 9999 | Error second threshold. Enter the threshold value in units of 10 ms.                                                               |
|                                                                                                                                                                                                                                                                                                                                                                                                                                                                                                                                                                                                                                                                                                                     | SES                    | 0 to 9999 | Severe error second threshold. Enter the threshold value in units of 10 ms.                                                        |
|                                                                                                                                                                                                                                                                                                                                                                                                                                                                                                                                                                                                                                                                                                                     | FRAMEML                | 0 to 9999 | Frame maintenance limit. Enter the maintenance limit for frame loss.                                                               |
|                                                                                                                                                                                                                                                                                                                                                                                                                                                                                                                                                                                                                                                                                                                     | FRAMEOL                | 0 to 9999 | Frame loss limit. Enter the OOS limit for frame loss.<br><br><b>Note:</b> The FRAMEOL must be larger than FRAMEML.                 |
|                                                                                                                                                                                                                                                                                                                                                                                                                                                                                                                                                                                                                                                                                                                     | SLIPML                 | 0 to 9999 | Slip maintenance limit. Enter the maintenance limit for slip.                                                                      |
|                                                                                                                                                                                                                                                                                                                                                                                                                                                                                                                                                                                                                                                                                                                     | SLIPOL                 | 0 to 9999 | Slip OOS limit. Enter the OOS limit for slip.<br><br><b>Note:</b> The SLIPOL must be larger than SLIPML.                           |
| <p><b>Note 1:</b> The DMS system adds the first tuple for SMS-R to table CARRMTC during initial program load (IPL) or first restart after IPL. The name of the entry is index 0. The name of the entry contains the value DEFAULT in the TMPLTNM field and default values for the other fields. Do not delete this tuple. The system changes fields ES, SES, and thresholds for frame and slip losses.</p> <p><b>Note 2:</b> Add tuples other than the default tuple before the tuples are referenced in table LTCRPINV. Delete these tuples if DS-1 carriers do not associate with these DS-1 carriers.</p> <p><b>Note 3:</b> Change tuples in table CARRMTC if the associated DS-1 carriers are ManB or OFFL.</p> |                        |           |                                                                                                                                    |

**Datafill example for table CARRMTC**

Sample datafill for table CARRMTC appear in the following example.

---

## Basic Call Processing (continued)

---

### MAP example for table CARRMTC

Table: CARRMTC

| CSPMTYPE | TMPLTNM | RTSML | RTSOL | ATTR |          |        |     |      |   |   |     |     |    |     |
|----------|---------|-------|-------|------|----------|--------|-----|------|---|---|-----|-----|----|-----|
| RCC2     | ESFB8ZF | 255   | 255   | DS1  | NTMX81AA | MU_LAW | ESF | B8ZS |   |   |     |     |    |     |
| CRC      | NILDL   | Y     | 100   | 300  | 50       | 50     | 150 | 1000 | 3 | 6 | 864 | 100 | 17 | 511 |
| 4        | 255     |       |       |      |          |        |     |      |   |   |     |     |    |     |

### Datafilling table PMLOADS

Table PMLOADS stores the device location of every PM loadfile. This table allows the XPM automatic loading feature to locate load files without the interruption of operating company personnel.

Table PMLOADS lists the active and a backup loadfiles. The active loadfile is the default load that the system uses with the LOADPDM command and most system activities. The system uses the backup loadfile if a problem occurs when the system loads or returns the active loadfile to service. The backup loadfile is the unpatched loadfile which Northern Telecom ships. The system uses the active and backup loadfiles during the application and removal of patches.

Table PMLOADS stores data for:

- the name of the active loadfile. This file is the default load the system uses with the LOADPDM command and most activities that the system initiates.
- the name of the backup loadfile. This file is the load the system uses for a problem. The system uses this file when the system loads or returns the active loadfile to service. The backup loadfile is the unpatched loadfile shipped with the SMS.
- the file locations.
- the update active loadfile field. This field indicates if the site requires an automatic update of the active fileid. The feature allows the system to load the patched loadfile in the XPM if a reload is necessary. This process simplifies reload and recovery of the XPM. If the system allows loadfile patching, the system updates active file information.

The system uses the active and backup files as part of the load and recovery process.

---

## Basic Call Processing (continued)

---

The system enters the XPM load file in table PMLOADS before the system enters the file in table LTCINV. Table LTCINV enforces this rule.

**Note:** An exception to this rule is present for the first entry and a dump and restore. During this action occurs, the system automatically enters tuples in table PMLOADS when the LTCINV tuples are entered.

### Pre-patched XPM loads

*Pre-patched XPM loads background.* Pre-patched XPM loads (PPXLs) are XPM loadfiles. The PPXL loadfiles contain corrective patches. The PPXLs are the increased loads and contain patch updates. The original use of the patch updates was the creation of patch files that are released to the field. A functional or technical difference is not present between a normal XPM load with patches and a PPXL where the patches are in the load. The PPXLs are like CM loads that have patches in by date of shipment.

*Start of PPXLs.* At the start of each PPXL loadfile, a 1K data block that contains the patch IDs for the patches in the PPXL is present. The files for each patchid that the 1K data block lists must be present when the PPXL is entered in table PMLOADS.

When table PMLOADS contains PPXL, one of the following processes occurs:

- the loadset is modified if a loadset for the base load is present.
- the loadset is created if the baseload is new to the DMS-100 switch.

**Note:** Loadsets group peripheral units that have the same load. To view the loadsets on the DMS-100 switch, access the PATCHER CI level and enter the command string INFORM PMALL.

After the addition of PPXL to table PMLOADS, you or the system can use the system recovery controller (SRC) to load the table. This process reduces or eliminates patching that occurs after the SRC loads the PPXL. The reduction or removal occurs because the load includes most or every patches.

After the SRC loads PPXL, application or removal of additional patches to PPXL can occur. This process is the same for a normal XPM load. The removal of patches in the PPX can occur if associated patch files are present.

The system can apply or remove patches that are added or removed after a PPXL is loaded. The system applies or removes the patches during the following reloads of the PPXL.

## Basic Call Processing (continued)

---

*PPXL Naming Procedure.* The PPXL file names have \_<date> added to the end of the base load name that corresponds to the file name. For example, a PPXL load file the system creates for base load ECL03BX is ECL03BX\_941129. The base load name remains the same. A load that does not have the \_<date> suffix is a base load.

The known value becomes the preservation of the patch stream with the ability to send a PPXL as required. Use the date identifier to identify the vintage of a PPXL.

*PPXL storage requirements.* When telephone companies prepare to load PPXLs, the companies must double the XPM load storage requirements to accommodate the PPXLs. The PPXLs require storage of the PPXL loadfile on the ACTVOL device. The PPXL require storage of the base load file on the BKPVOL device.

### Loading a PPXL

Two methods are available for the addition of PPXLs to an office. For the first method, upgrade an office to a new base load sequence. Use this method when the base loadname is not in table PMLOADS. For the second method, add PPXLs to offices that already have the base loadname in table PMLOADS. For example, when the ESC03CJ (the current loadname) is added to ESC03CJ\_950105 (the PPXL added to the baseload). The two methods are:

1. the system supports PPXLs on BCS36 or later version CM loads
2. apply PATCH JCK19 to the CM before you continue.

### Upgrading the base load

To load a PPXL in an office where the baseload is new to the office, use the following procedure:

- 1 Copy the base loadfile and the PPXL loadfiles to the disk volumes for the PM loads.

**Note:** Copy the base load and the PPXL loadfiles to two disk volumes for redundancy.

- 2 Copy the patches that associate with the PPXL loads to the same disk volume from step 1. The load tape shipment includes a list of patches that associate with each PPXL load. After the PPXL file is on disk, obtain a list of patches that the PPXL includes. To obtain a list, type

```
>XPMLFP
```

and press the Enter key.

```
>PATCHLIST FILE ppxl_filename
```

and press the Enter key.



---

## Basic Call Processing (continued)

---

where

**ppxl\_filename**

is the PPXL filename added to the base load

- 3 Add a new tuple for the base load to table PMLOADS. Enter the base load for the LOADNAME. Enter the base loadname for the ACTFILE. Enter the base load name for the BKPFIL.
  - 4 Add the base loadname to the appropriate inventory table. An example of an inventory table is LTCINV
  - 5 Edit the tuple added in step 3 to change the ACTFILE field from the base loadfile name to the PPXL filename. Refer to the datafill example for table PMLOADS for an example of this tuple.
  - 6 To set the loadset against the two units of the XPM, type
 

```
>PATCHER
```

 and press the Enter key.
 

```
>SET loadname PM pm_type device_no unit_no
```

 and press the Enter key.

where

**loadname**

is the name of the loadfile

**pm\_type**

is the type of PM that requires the loadset

**device\_no**

is the device number with a range of 0-255

**unit\_no**

is the unit number, 0 or 1

- 7 To load the PPXL in each unit of the XPM, type
 

```
>BSY UNIT unit_no
```

 and press the Enter key.
 

```
>LOADPM UNIT unit_no
```

 and press the Enter key.
 

```
>RTS UNIT unit_no
```

 and press the Enter key.

where

**unit\_no**

is the unit number of the XPM to load

- 8 Perform a SWACT of the XPM. Repeat step 7.

**Note 1:** When the XPM is loaded, you can apply or remove additional patches. The method to apply or remove patches is the method for earlier XPMs. You can remove patches in the PPXL if the patchfile is on disk.

**Note 2:** The system applies or removes patches that are added or removed after a PPXL is loaded. The system adds or removes patches during the next reloads of the PPXL.

---

## Basic Call Processing (continued)

---

**Note 3:** The system does not remove non-PPXL patches when the SRC reloads the PPXL. The removed patches are already out of the loadset.

### Adding PPXLs to a current PM load lineup

To add PPXLs to a current XPM load lineup, use the following procedure:

- 1 Verify that the patch\_ids that associate with the PPXL are present on the disk volume table PMLOADS that field ACTVOL identifies. If these patch\_ids are not present, copy the patches from tape to the correct volume. The PM tape shipment includes a list of patches that each PPXL contains. After you copy the PPXLs to disk, list the patches in the PPXL. To list the patches, type

```
>XPMLFP
```

and press the Enter key.

```
>PATCHLIST FILE ppxl_filename
```

and press the Enter key.

where

**ppxl\_filename**

is the filename of the PPXL loaded to disk

- 2 Copy the PPXL file (filename\_date) to the disk volume from step 1.
- 3 Copy the baseload to the disk volume table PMLOADS, field BKPVOL identifies.
- 4 Modify table PMLOADS in the following way. If table PMLOADS does not contain the XPM base loadname, add a new tuple. Use the earlier Upgrading baseload lineup procedure to add the tuple. If the table PMLOADS contains the XPM base loadname, change the ACTFILE field to the PPXL filename (filename\_date). The system upgrades the loadset if a loadset is already present. The system creates a loadset if a loadset is not present.
- 5 To set the loadset against the two units of the XPM, type

```
>PATCHER
```

and press the Enter key.

```
>SET loadname PM pm_type device_no unit_no
```

and press the Enter key.

where

**loadname**

is the name of the loadfile

**pm\_type**

is the type of PM that requires the loadset

**device\_no**

is the device number with a range of 0-255

**unit\_no**

is the unit number, 0 or 1

- 6 To load each unit of the XPM with the PPXL, type

```
>BSY UNIT unit_no
```

---

## Basic Call Processing (continued)

---

and press the Enter key.

>LOADPM UNIT *unit\_no*

and press the Enter key.

>RTS UNIT *unit\_no*

and press the Enter key.

where

**unit\_no**

is the unit number of the XPM you must load

- 7 Perform a SWACT of the XPM. Repeat step 6.

**Note 1:** When the XPM is loaded, you can apply or remove additional patches. The method you use to apply or remove patches is the same as the method for earlier XPMs. You can remove patches in the PPXL if the patchfile is on disk.

**Note 2:** The system applies or removes patches that are added or removed after a PPXL is loaded. The system adds or removes patches during the next reloads of the PPXL.

Datafill specific to Basic Call Processing for table PMLOADS appear in the following table. Only fields that apply to Basic Call Processing appear.

**Datafilling table PMLOADS (Sheet 1 of 2)**

| Field    | Subfield or refinement | Entry        | Description                                                                                                                                                                                                                          |
|----------|------------------------|--------------|--------------------------------------------------------------------------------------------------------------------------------------------------------------------------------------------------------------------------------------|
| LOADNAME |                        | alphanumeric | Peripheral module load name. Enter the XPM load file name. The range is a maximum of eight characters.                                                                                                                               |
| ACTFILE  |                        | alphanumeric | Active load file name. The name of the active XPM loadfile. This name is the original loadfile or a patched loadfile (PPXL). Range is a maximum of 32 characters.                                                                    |
| ACTVOL   |                        | alphanumeric | Active volume. Identifies the device that stores loadfile. Range is the set of disk drive unit (DDU) volumes and system load module (SLM) disks that is available to the CM (that is, S00DXPM). Range is a maximum of 16 characters. |
| BKPFIL   |                        | alphanumeric | Backup load file name. Identifies the name of the backup XPM loadfile. The name must be the same name as the LOADNAME field. Range is a maximum of 32 characters.                                                                    |

## Basic Call Processing (continued)

### Datafilling table PMLOADS (Sheet 2 of 2)

| Field  | Subfield or refinement | Entry        | Description                                                                                                                                                                  |
|--------|------------------------|--------------|------------------------------------------------------------------------------------------------------------------------------------------------------------------------------|
| BKPVOL |                        | alphanumeric | Backup volume. The device that stores the backup loadfile. Range is the set of DDU volumes and SLM disks available to the CM (S00DXPM). Range is a maximum of 16 characters. |
| UPDACT |                        | alphanumeric | Update active filename. Not in use. The default value is N.                                                                                                                  |

### Datafill example for table PMLOADS

Sample datafill for table PMLOADS appear in the following example.

### MAP example for table PMLOADS

| LOADNAME       | ACTFILE | ACTVOL   | BKPFIL | BKPVOL | UPDACT |
|----------------|---------|----------|--------|--------|--------|
| -----          |         |          |        |        |        |
| ESC02CVJ       |         |          |        |        |        |
| ESC02CJ_950205 |         | S001DXPM |        |        |        |
| ESC02CJ        |         | S001DXPM |        |        | N      |

### Datafilling table LTCRINV

Datafill specific for Basic Call Processing for table LTCRINV appear in the following table. Only fields that apply to Basic Call Processing appear. For a description of the other fields, refer to the data schema section of this document.

The line trunk controller remote inventory table (LTCRINV) contains the inventory data. This data does not include P-side link assignments. These

**Basic Call Processing** (continued)

assignments are in table LTCRINV, for different PM types that include the SMS-R.

**Datafilling table LTCRINV (Sheet 1 of 3)**

| Field                                                                                                                                                                                                                                                                                                                                                                                                                                                                                                                                                                                                                                                                                                                                                                                                                                                                                                                                                                                                                                     | Subfield or refinement | Entry                          | Explanation and action                                                                                                                                                                                                                                                                                  |
|-------------------------------------------------------------------------------------------------------------------------------------------------------------------------------------------------------------------------------------------------------------------------------------------------------------------------------------------------------------------------------------------------------------------------------------------------------------------------------------------------------------------------------------------------------------------------------------------------------------------------------------------------------------------------------------------------------------------------------------------------------------------------------------------------------------------------------------------------------------------------------------------------------------------------------------------------------------------------------------------------------------------------------------------|------------------------|--------------------------------|---------------------------------------------------------------------------------------------------------------------------------------------------------------------------------------------------------------------------------------------------------------------------------------------------------|
| LTCRNAME                                                                                                                                                                                                                                                                                                                                                                                                                                                                                                                                                                                                                                                                                                                                                                                                                                                                                                                                                                                                                                  |                        | refer to subfields             | Line trunk controller remote name. Contains subfields SITENM, PMTYPE, and XPMNO.                                                                                                                                                                                                                        |
|                                                                                                                                                                                                                                                                                                                                                                                                                                                                                                                                                                                                                                                                                                                                                                                                                                                                                                                                                                                                                                           | SITENM                 | alphabetical                   | Site name. Enter where the peripheral belongs (site name in table SITE).                                                                                                                                                                                                                                |
|                                                                                                                                                                                                                                                                                                                                                                                                                                                                                                                                                                                                                                                                                                                                                                                                                                                                                                                                                                                                                                           | PMTYPE                 | SMSR, RCC2, SRCC               | Peripheral module type. Enter the name of the PM type.                                                                                                                                                                                                                                                  |
|                                                                                                                                                                                                                                                                                                                                                                                                                                                                                                                                                                                                                                                                                                                                                                                                                                                                                                                                                                                                                                           | XPMNO                  | 0 to 255                       | Peripheral module number. Enter the PM number.<br><br><b>Note:</b> Operating company personnel can number the XPMs from 0 to 255 but the total number of tuples in tables LTCINV and LTCRINV combined cannot exceed 210 XPMs. The XPM types can be any combination of types accepted by the two tables. |
| FRTYPE                                                                                                                                                                                                                                                                                                                                                                                                                                                                                                                                                                                                                                                                                                                                                                                                                                                                                                                                                                                                                                    |                        | LTE, DTE, LGE, SME, IDTE, MCTM | Frame type. Enter the frame type where the system mounts the PM equipment.                                                                                                                                                                                                                              |
| FRNO                                                                                                                                                                                                                                                                                                                                                                                                                                                                                                                                                                                                                                                                                                                                                                                                                                                                                                                                                                                                                                      |                        | 0 to 511                       | Frame number. Enter the frame number of the subscriber module equipment (SME) frame.                                                                                                                                                                                                                    |
| SHPOS                                                                                                                                                                                                                                                                                                                                                                                                                                                                                                                                                                                                                                                                                                                                                                                                                                                                                                                                                                                                                                     |                        | 18, 32, 51, 65                 | Shelf position. Enter the position of the shelves on the frame in inches above the floor level.                                                                                                                                                                                                         |
| <p><b>Note 1:</b> Enter the loadname in table PMLOADS before you enter data in table LTCRINV.</p> <p><b>Note 2:</b> The system automatically allocates memory for a maximum of 128 tuples in the NT40. The system also automatically allocates memory for 256 tuples in the DMS SuperNode for table LTCRINV. Memory is allocated as required to allow a maximum sum of 210 tuples in tables LTCINV and LTCRINV combined.</p> <p><b>Note 3:</b> When you enter data in field C-side link table (CSLNKTAB), make sure message links are not assigned to the same interface card. When the interface card supports two or more links, separate the message links by the number of links on the interface cards. This action applies to all interface link types: DS-1, DS30, DS30A, or PCM-30. Table control issues a warning if you attempt to assign message links on the same interface card. If you assign message links to the same interface card, an E1 power failure (failure of all message links) can occur if the card fails.</p> |                        |                                |                                                                                                                                                                                                                                                                                                         |

**Basic Call Processing** (continued)

Datafilling table LTCRINV (Sheet 2 of 3)

| Field | Subfield or refinement | Entry                              | Explanation and action                                                                                                                 |
|-------|------------------------|------------------------------------|----------------------------------------------------------------------------------------------------------------------------------------|
| FLOOR |                        | 0 to 99                            | Floor. Enter a floor number. This floor number must be the location of where the system locates the peripheral module equipment frame. |
| ROW   |                        | A-H, J-N, P-Z, AA-HH, JJ-NN, PP-ZZ | Row. Enter a row. This row must be the location of the PM equipment frame.                                                             |
| FRPOS |                        | 0 to 99                            | Frame position. Enter the position in the row of the PM equipment frame.                                                               |
| EQPEC |                        | alphanumeric                       | Equipment product engineering code. Enter the PEC of the PM.                                                                           |
| LOAD  |                        | alphanumeric                       | Load. Enter the issue name of the PM software.                                                                                         |
| CSPM  |                        | refer to subfields                 | The C-side peripheral module. Enter the name of the C-side peripheral or the host node consisting of SITETYPE, PM TYPE, and PM NO.     |
|       | SITETYPE               | refer to subfields                 | Site type. This subfield contains subfields SITE and PMT.                                                                              |
|       | SITE                   | alphanumeric (HOST, REM1, REM2)    | Site. Enter the site name from table SITE.                                                                                             |
|       | PMT                    | SMSR, RCC2                         | Peripheral module type. Enter the C-side host peripheral module type.                                                                  |

**Note 1:** Enter the loadname in table PMLOADS before you enter data in table LTCRINV.

**Note 2:** The system automatically allocates memory for a maximum of 128 tuples in the NT40. The system also automatically allocates memory for 256 tuples in the DMS SuperNode for table LTCRINV. Memory is allocated as required to allow a maximum sum of 210 tuples in tables LTCRINV and LTCRINV combined.

**Note 3:** When you enter data in field C-side link table (CSLNKTAB), make sure message links are not assigned to the same interface card. When the interface card supports two or more links, separate the message links by the number of links on the interface cards. This action applies to all interface link types: DS-1, DS30, DS30A, or PCM-30. Table control issues a warning if you attempt to assign message links on the same interface card. If you assign message links to the same interface card, an E1 power failure (failure of all message links) can occur if the card fails.

**Basic Call Processing** (continued)**Datafilling table LTCRINV (Sheet 3 of 3)**

| Field                                                                                                                                                                                                                                                                                                                                                                                                                                                                                                                                                                                                                                                                                                                                                                                                                                                                                                                                                                                                                                      | Subfield or refinement | Entry                                 | Explanation and action                                                                                                                                                                                                                                                                                                                                                                                          |
|--------------------------------------------------------------------------------------------------------------------------------------------------------------------------------------------------------------------------------------------------------------------------------------------------------------------------------------------------------------------------------------------------------------------------------------------------------------------------------------------------------------------------------------------------------------------------------------------------------------------------------------------------------------------------------------------------------------------------------------------------------------------------------------------------------------------------------------------------------------------------------------------------------------------------------------------------------------------------------------------------------------------------------------------|------------------------|---------------------------------------|-----------------------------------------------------------------------------------------------------------------------------------------------------------------------------------------------------------------------------------------------------------------------------------------------------------------------------------------------------------------------------------------------------------------|
|                                                                                                                                                                                                                                                                                                                                                                                                                                                                                                                                                                                                                                                                                                                                                                                                                                                                                                                                                                                                                                            | XPMNO                  | 0 to 255                              | Extended peripheral module number. Enter the number of the node within the peripheral module type.                                                                                                                                                                                                                                                                                                              |
| CSLNKTAB                                                                                                                                                                                                                                                                                                                                                                                                                                                                                                                                                                                                                                                                                                                                                                                                                                                                                                                                                                                                                                   |                        | vector of a maximum of 16 CSPM ports. | The C-side link table. Enter the C-side port number of the peripheral module.                                                                                                                                                                                                                                                                                                                                   |
| OPTCARD                                                                                                                                                                                                                                                                                                                                                                                                                                                                                                                                                                                                                                                                                                                                                                                                                                                                                                                                                                                                                                    |                        | MSG6X69                               | Optional card. The range of values for the SMS-R includes MSG6X69, the default.<br><br>The system enters NT7X05AA. The system prompts for the slot_number. Use slot 17 or 15 if available.                                                                                                                                                                                                                      |
| PECS6X45                                                                                                                                                                                                                                                                                                                                                                                                                                                                                                                                                                                                                                                                                                                                                                                                                                                                                                                                                                                                                                   |                        | alphanumeric                          | The 6X45 equipment PECS. The 6X45 processor type Equipment PECs. Enter the two product engineering codes of the MX77 card if equipped. Each unit of the SMS requires one PEC. Enter the PEC for unit 0 first. The PEC entered for a unit must correspond to the minimum firmware capabilities between the MX77s in the processor complex. For example, if the UPs are MX77AA, enter MX77AA twice in this field. |
| <p><b>Note 1:</b> Enter the loadname in table PMLOADS before you enter data in table LTCRINV.</p> <p><b>Note 2:</b> The system automatically allocates memory for a maximum of 128 tuples in the NT40. The system also automatically allocates memory for 256 tuples in the DMS SuperNode for table LTCRINV. Memory is allocated as required to allow a maximum sum of 210 tuples in tables LTCRINV and LTCRINV combined.</p> <p><b>Note 3:</b> When you enter data in field C-side link table (CSLNKTAB), make sure message links are not assigned to the same interface card. When the interface card supports two or more links, separate the message links by the number of links on the interface cards. This action applies to all interface link types: DS-1, DS30, DS30A, or PCM-30. Table control issues a warning if you attempt to assign message links on the same interface card. If you assign message links to the same interface card, an E1 power failure (failure of all message links) can occur if the card fails.</p> |                        |                                       |                                                                                                                                                                                                                                                                                                                                                                                                                 |

**Datafill example for table LTCRINV**

Sample datafill for table LTCRINV appears in the following example.

## Basic Call Processing (continued)

### MAP example for table LTCRINV

|                |      |       |        |     |            |         |         |          |  |  |    |  |
|----------------|------|-------|--------|-----|------------|---------|---------|----------|--|--|----|--|
| Table: LTCRINV |      |       |        |     |            |         |         |          |  |  |    |  |
| LTCRNAME       |      |       |        |     |            |         |         |          |  |  |    |  |
| FRTYPE         | FRNO | SHPOS | FLOOR  | ROW | FRPOS      | EQPEC   | LOAD    | CSLNKTAB |  |  |    |  |
|                |      |       |        |     |            |         | OPTCARD |          |  |  |    |  |
| PECS6X45       |      |       |        |     |            |         |         |          |  |  |    |  |
| -----          |      |       |        |     |            |         |         |          |  |  |    |  |
| RSC0           | SMSR | 0     |        |     |            |         |         |          |  |  |    |  |
|                | SME  | 15    | 54     | 31  | BB         | 5       | 6X02PA  | SSR33BX  |  |  |    |  |
|                | KRCC | RCC   | 0      |     |            |         |         |          |  |  |    |  |
| \$             |      |       |        |     | (10)       | (11)    | (12)    | (13)     |  |  |    |  |
| \$             |      |       |        |     |            |         |         |          |  |  |    |  |
|                |      |       |        |     | (NT7X05AA) | MSG6X69 |         |          |  |  | \$ |  |
| MX77AA         |      |       | MX77AA |     |            |         |         |          |  |  |    |  |

### Datafilling table LTCRPINV

Datafill specific to Basic Call Processing for table LTCRPINV appear in the following table. Only fields that apply to Basic Call Processing appear. For a description of the other fields, refer to the data schema section of this document.



---

## Basic Call Processing (continued)

---

The line trunk controller remote P-side link inventory table (LTCRPINV) lists the following data assignment for each bay associated with an SMS-R unit:

- PM type and number
- port identification of the P-side links

### Datafilling table LTCRPINV

| Field                                                                                                                                                                                                                                                                                                        | Subfield or refinement | Entry                    | Explanation and action                                                                                                                                                                                                                                   |
|--------------------------------------------------------------------------------------------------------------------------------------------------------------------------------------------------------------------------------------------------------------------------------------------------------------|------------------------|--------------------------|----------------------------------------------------------------------------------------------------------------------------------------------------------------------------------------------------------------------------------------------------------|
| LTCRNAME                                                                                                                                                                                                                                                                                                     |                        | refer to subfields       | Line trunk controller remote name. This field contains subfields SITENM, PMTYPE, and XPMNO.                                                                                                                                                              |
|                                                                                                                                                                                                                                                                                                              | SITENM                 | alphanumeric (HOST REM1) | Site name. Enter the location of the peripheral (site name in table SITE).                                                                                                                                                                               |
|                                                                                                                                                                                                                                                                                                              | PMTYPE                 | SMSR, RCC2, or SRCC      | Peripheral module type. Enter the name of the PM type.                                                                                                                                                                                                   |
|                                                                                                                                                                                                                                                                                                              | XPMNO                  | 0 to 127                 | Peripheral module number. Enter the PM number.                                                                                                                                                                                                           |
| PSLNKTAB                                                                                                                                                                                                                                                                                                     |                        | refer to subfields       | The P-side link table. Contains subfields PSLINK, PSDATA, and CONTMARK.                                                                                                                                                                                  |
|                                                                                                                                                                                                                                                                                                              | PSLINK                 | 0 to 19                  | The P-side link. Enter the P-side port number. Range: 0-19.                                                                                                                                                                                              |
|                                                                                                                                                                                                                                                                                                              | PSDATA                 | DS1 or NILTYPE           | The P-side data. Enter DS1 for a DS-1 type interface card. The NILTYPE is the default value. Do not enter NILTYPE for the first input. If the entry is NILTYPE, do not enter additional fields. If the entry is DS1, enter subfields CARRIDX and ACTION. |
| <p><b>Note 1:</b> The system allocates memory for a maximum of 128 tuples in the NT40 and 256 tuples in the DMS SuperNode for table LTCRPINV.</p> <p><b>Note 2:</b> The system automatically enters table LTCRPINV with table LTCRINV entered. Tuples cannot be added or deleted. Tuples can be changed.</p> |                        |                          |                                                                                                                                                                                                                                                          |

### Datafill example for table LTCRPINV

Sample datafill for table LTCRPINV appear in the following example.

## Basic Call Processing (continued)

### MAP example for table LTCRPINV

```

Table: LTCRPINV

PMTYPE PMNO PSLNKTAB

RSC1 SMSR 0
(0 DS1 DEFAULT N) (1 DS1 DEFAULT N) (2 NILTYPE)
(3 NILTYPE) (4 DS1 DEFAULT N) (5 NILTYPE)
(6 NILTYPE) (7 NILTYPE) (8 NILTYPE)
(9 DS1 NILTYPE N) (10 DS1 DEFAULT N) (11 NILTYPE)
(12 NILTYPE) (13 NILTYPE) (14 NILTYPE) (14 NILTYPE)
(15 NILTYPE) (16 NILTYPE) (17 NILTYPE) (18
NILTYPE) (19 NILTYPE) $

```

## Datafilling the table RCSINV

### Controlling modes

The RCS contains four line shelves. These line shelves are A, B, C, and D. Shelves A and B belong to shelf group AB. Shelves C and D belong to shelf group CD. Each shelf group operates separate from the other shelf group. The shelf group operates in one of the following modes:

- mode I  
Not concentrated shelf group is for single and multiparty lines. One or two DS-1 lines connect to a shelf group. The number of lines depends on the number of equipped shelves.
- mode II  
Concentrated shelf group in which a maximum of 48 lines of each shelf group are concentrated on 24 channels. One DS-1 line connects to a shelf group in this mode.
- mode III  
Not concentrated shelf group where the complete shelf group is dedicated to coin, data lines, or other special service lines. One DS-1 line connects to a shelf group in this mode.

The mode of a shelf group depends on the cards in the SLC-96 system. The mode does not change under program control.

The C-side link information in the RCS depends on the mode of operation of each of two shelf groups. In mode I, one or two C-side links for a shelf group are available. In modes II and III, only one C-side link for each shelf group can be available.

---

## Basic Call Processing (continued)

---

### Protection lines

A protection line (PROTLINE) is a standby DS-1 link between the SMS-R and RCS. The protection line is always powered up and transmits a bit stream identical to the A-link. The process to switch the A-link takes less time than the B-links, C-links, or D-links. The system assigns only one RCS to a single PROTLINE. The ratio of PROTLINES to normal DS-1 links (*normlines*) can be 1 to 2, 1 to 3, or 1 to 4. This ratio depends on the mode of operation of the shelf groups.

A protection switch preserves calls in the talking and ringing states. The switch does not preserve calls not in the digit collection state. If any DS-1 line is part of a nailed-up cross-connection, do not use that DS-1 as a protection line. Datafill for table RCSINV is affected because the SMS-R P-side port where a protection line connects is entered. The SMS-R P-side port where a DS-1 line connects cannot be entered as the protection line port. This DS-1 line is part of a nailed-up cross-connection.

A DS-1 line has channels that are part of a nailed-up cross-connection. The endpoint in the table PSNAILUP is listed as a channel, not a line. You cannot attach an RCS to this line in the table RCSINV.

**Note 1:** An SMS-R DS-1 interface card contains two ports for DS-1 links. Two DS-1 links that lead from the same SMS-R DS-1 card must connect to different RCS modules. With the connection of one DS-1 link to an RCS, removal of an interface card occurs. This removal must not interrupt continuous calls. The DS-1 links that connect an SMS-R DS-1 card to an RCS are protection switched.

**Note 2:** To change the position of a DS-1 link on an RCS, the switch operator must reposition all DS-1 links on the RCS. For example, four DS-1 links are assigned to SMS-R P-side links 0, 1, 2, and 3 (LKINFO field of table RCSINV). The switch operator repositions link 0 as link 5. The switch operator must reposition links 1, 2, and 3 at the same time as new links. These links are, for example, 6, 7, and 8. The switch operator must reposition all links. The switch operator can return links 6, 7, and 8 to their first assignments as links 1, 2, and 3. All DS-1 links (SMS-R ports) are in use. The switch operator must reposition one link and delete the RCS. The switch operator must add the RCS to the system.

**Note 3:** The system allocates memory for a maximum of 255 entries.

Datafill that relates to Basic Call Processing for table RCSINV appear in the following table. Only the fields that apply to Basic Call Processing appear. For

## Basic Call Processing (continued)

a description of the other fields, refer to the data schema section of this document.

**Datafilling table RCSINV (Sheet 1 of 4)**

| Field              | Subfield or refinement | Entry                                                         | Explanation and action                                                                                                                                                                                                                                                                 |
|--------------------|------------------------|---------------------------------------------------------------|----------------------------------------------------------------------------------------------------------------------------------------------------------------------------------------------------------------------------------------------------------------------------------------|
| RCSNO              |                        | refer to subfields                                            | Remote concentrator module number. This field contains subfields SITE, FRAME, and UNIT.                                                                                                                                                                                                |
| ADNUM<br>(BCS35 -) |                        | 0 to 4095                                                     | Administrative number. Enter a number to represent the administrative number for an associated peripheral module.                                                                                                                                                                      |
|                    | SITE                   | alphanumeric                                                  | Site. Enter the location of the RCS. This entry is not optional. This entry does not have a default.                                                                                                                                                                                   |
|                    | FRAME                  | 0 to 511                                                      | Frame. Enter the remote concentrator module frame number. This number is not a physical frame, and a software entity that identifies the RCS modules. These modules share the same metallic test pair. All RCS modules sharing the same metallic test pair have the same frame number. |
|                    | UNIT                   | 0 to 9                                                        | Unit. Enter the remote concentrator module unit number. Range: 0 to 9.                                                                                                                                                                                                                 |
| FRTYPE             |                        | RCE                                                           | Frame type. Enter the frame type of the frame the PM equipment occupies.                                                                                                                                                                                                               |
| FRNO               |                        | 0 to 511                                                      | Frame number. Enter the frame number of the RCS. This number differs for each office.                                                                                                                                                                                                  |
| SHPOS              |                        | 0 to 77                                                       | Shelf position. Enter the position of the RCS control shelf in inches above the floor level.                                                                                                                                                                                           |
| FLOOR              |                        | 0 to 99                                                       | Floor. Enter the floor number that represents the location of the PM equipment frame.                                                                                                                                                                                                  |
| ROW                |                        | A to H, J to N,<br>P to Z, AA to<br>HH, JJ to NN,<br>PP to ZZ | Row. Enter the row letter that represents the location of the PM equipment frame.                                                                                                                                                                                                      |
| FRPOS              |                        | 0 to 99                                                       | Frame position. Enter the position in the row of the PM equipment frame.                                                                                                                                                                                                               |

**Basic Call Processing** (continued)

Datafilling table RCSINV (Sheet 2 of 4)

| Field  | Subfield or refinement | Entry                              | Explanation and action                                                                                                                                                                                                                                                                                                                                                                                                                                                                                          |
|--------|------------------------|------------------------------------|-----------------------------------------------------------------------------------------------------------------------------------------------------------------------------------------------------------------------------------------------------------------------------------------------------------------------------------------------------------------------------------------------------------------------------------------------------------------------------------------------------------------|
| LOAD   |                        | alphanumeric                       | Load. Enter the issue name of the PM software. The RCS does not require a load. This field is entered as NO_LOAD.                                                                                                                                                                                                                                                                                                                                                                                               |
| CSPMNO |                        | refer to subfields                 | The C-side PM number. Contains subfields PMTYPE and PMNO.                                                                                                                                                                                                                                                                                                                                                                                                                                                       |
|        | PMT                    | SMS or SMSR                        | Peripheral module type. Enter the type of PM that has the RCS.                                                                                                                                                                                                                                                                                                                                                                                                                                                  |
|        | EXTPMNO                | 0 to 127                           | Peripheral module number. Enter the PM number with the RCS.                                                                                                                                                                                                                                                                                                                                                                                                                                                     |
| ABINFO |                        | refer to subfields                 | The AB shelf group information. This field contains subfields SHLFGRPMODE and XPMPORT.                                                                                                                                                                                                                                                                                                                                                                                                                          |
|        | SHLFGRPMODE            | MODE1, MODE2, MODE3, or NILMODE    | Mode. Enter the mode of operation of shelf group AB. The entry NILMODE can appear as a selection. The entry NILMODE is not recommended because the system does not support NILMODE. If entry of MODE2 occurs, the subfield LOOPTEST must be entered.                                                                                                                                                                                                                                                            |
|        | XPMPORT                | vector of a maximum of 2 (0 to 19) | The C-side link information. Enter the SMS-R P-side ports where C-side links CDLK0 to CDLK1 of the RCS are assigned. This information is a vector with a minimum of one entry or a maximum of two entries. Enter a dollar sign (\$) to terminate the vector. For MODE2 and MODE3 use CDLK0. For MODE1 use CDLK0 when equipped with one shelf. Use CDLK0 and CDLK1 when equipped with two shelves.                                                                                                               |
|        | LOOPTEST               | Y or N                             | The PCM looping test. Enter Y to enable PCM looping test in MODE2. This field appears only for MODE2 shelf groups. If the PCM looping test fails, a minor alarm can occur. If the PCM looping test fails, call processing does not use the associated DS-1 channel and line card (channel unit). The PCM looping test runs often to identify the correction of the problem. The PCM looping test failure on two DS-1 channels causes a major alarm. The system removes the associated shelf group from service. |

**Basic Call Processing** (continued)

Datafilling table RCSINV (Sheet 3 of 4)

| Field   | Subfield or refinement | Entry                                    | Explanation and action                                                                                                                                                                                                                                                                                                                                                                                                                                                                                     |
|---------|------------------------|------------------------------------------|------------------------------------------------------------------------------------------------------------------------------------------------------------------------------------------------------------------------------------------------------------------------------------------------------------------------------------------------------------------------------------------------------------------------------------------------------------------------------------------------------------|
| CDINFO  |                        | refer to subfields                       | The CD shelf group information. This field contains subfields SHLFGRPMODE, and XPMPORT.                                                                                                                                                                                                                                                                                                                                                                                                                    |
|         | SHLFGRPMODE            | MODE1, MODE2, MODE3, or NILMODE          | Mode. Enter the mode of operation of shelf group AB. The entry NILMODE appears as an option. The entry NILMODE is not recommended because the system does not support the entry NILMODE. Enter the subfield LOOPFIELD if MODE2 is entered.                                                                                                                                                                                                                                                                 |
|         | XPMPORT                | vector of a maximum of 2 (0 to 19)       | The C-side link information. Enter the SMS-R P-side ports where the system assigns C-side links CDLK0 to CDLK1 of the RCS. This information is a vector. At a minimum of one entry or a maximum of two entries, enter a dollar sign (\$) to terminate the vector. For MODE2 and MODE3, use CDLK0. For MODE1, use CDLK0 when equipped with one shelf. Use CDLK0 and CDLK1 when equipped with two shelves.                                                                                                   |
|         | LOOPTEST               |                                          | The PCM looping test. Enter Y to enable PCM looping test in MODE2. This field appears only for MODE2 shelf groups. If the PCM looping test fails, a minor alarm can occur. If the PCM looping test fails, call processing does not use the associated DS-1 channel and line card (channel unit). The PCM looping test runs often to identify if the problem is corrected. A PCM looping test failure on two DS1 channels causes a major alarm. The system removes the associated shelf group from service. |
| RNGTYPE |                        | C, F, S, UNASSIGNED, D, C30, CSR, or C3D | Ring type. Enter the type of ringing assigned to the remote concentrator module.                                                                                                                                                                                                                                                                                                                                                                                                                           |
| ACU     |                        | WP1, WP1B                                | Alarm control unit. Enter the type of alarm control unit circuit pack. The difference between these two cards is the format of the alarm message. This system sends this message to the office through the derived data link (DDL).                                                                                                                                                                                                                                                                        |

**Basic Call Processing** (continued)

Datafilling table RCSINV (Sheet 4 of 4)

| Field    | Subfield or refinement | Entry              | Explanation and action                                                                                                                                                                                                                                                                                                                                                                                       |
|----------|------------------------|--------------------|--------------------------------------------------------------------------------------------------------------------------------------------------------------------------------------------------------------------------------------------------------------------------------------------------------------------------------------------------------------------------------------------------------------|
| PROTINFO |                        | Y or N             | Protection. Enter Y if the RCS contains a protection line. Enter N if the RCS does not have a protection line. If the entry is Y, enter the PORT number.                                                                                                                                                                                                                                                     |
|          | PORT                   | 0 to 19            | Port. Enter the SMS-R P-side port number of the protection line.                                                                                                                                                                                                                                                                                                                                             |
| SCDINFO  |                        | refer to subfields | Scan and SD points information. This field contains subfields SCSDUSED, INHSCGRP, INHSCPT, INHSDGRP, and INHSDPT.                                                                                                                                                                                                                                                                                            |
|          | SCSDUSED               | Y or N             | Scan or SD points used. Enter Y if the RCS requires an inhibit lead. Enter N if the RCS does not require an inhibit lead. If the entry is Y, enter the subfields that remain in this table.                                                                                                                                                                                                                  |
|          | INHSCGRP               | 0 to 511           | Inhibit scan group. Enter the number of the scan group that contains the scan point for the inhibit lead function. Table SCGRP defines this scan group.                                                                                                                                                                                                                                                      |
|          | INHSCPT                | 0 to 6             | Inhibit scan point. Enter the number of the scan point for the inhibit lead function.                                                                                                                                                                                                                                                                                                                        |
|          | INHSDGRP               | 0 to 511           | Inhibit signal distribution group. Enter the number of the SD group that contains the SD point for the inhibit lead function. Table SDGRP defines this SD group.                                                                                                                                                                                                                                             |
| INHSDPT  |                        | 0 to 6             | Inhibit signal distribution point. Enter the number of the SD point for the inhibit lead function.                                                                                                                                                                                                                                                                                                           |
|          |                        |                    |                                                                                                                                                                                                                                                                                                                                                                                                              |
| MISCTEXT |                        | alphanumeric       | Miscellaneous text. Enter the text associated with the power/miscellaneous alarm. The maximum length is 16 characters. Use the underscore ( _ ) instead of blanks to separate words. Text you enter after blanks are truncated. The underscores are converted to blanks before the underscores are displayed. The text appears in PM128 logs and in specified MAP displays when the associated alarm occurs. |
| ALMSEVER |                        | MINOR or MAJOR     | Alarm severity. Enter the severity of the alarm.                                                                                                                                                                                                                                                                                                                                                             |

## Basic Call Processing (continued)

### Datafill example for table RCSINV

Sample datafill for table RCSINV appear in the following example.

### MAP example for table RCSINV

| Table: RCSINV |           |          |       |       |       |     |       |      |        |         |        |         |     |          |
|---------------|-----------|----------|-------|-------|-------|-----|-------|------|--------|---------|--------|---------|-----|----------|
| RCSNO         | ADNUM     | FRTYPE   | FRNO  | SHPOS | FLOOR | ROW | FRPOS | LOAD | CSPMNO | ABINFO  | CDINFO | RNGTYPE | ACU | PROTINFO |
| SCSDINFO      | MISCTEXT  | ALMSEVER |       |       |       |     |       |      |        |         |        |         |     |          |
| RCS1          | 00        | 0        | 14    | MIS   | 1     | 18  | 1     | C    | 8      | NO_LOAD | SMSR   | 0       |     |          |
| MODEL         | (0)       | (2)\$    | MODEL | (4)   | (6)\$ | S   | WP1B  | Y    | 8      |         |        |         |     |          |
| N             | HIGH_TEMP | MAJOR    |       |       |       |     |       |      |        |         |        |         |     |          |

### Datafilling table TMINV

Datafill that relates to Basic Call Processing for table TMINV appear in the following table. Only fields that apply to Basic Call Processing appear. For a description of the other fields, refer to the data schema section of this document.

The trunk module inventory table (TMINV) contains hardware and software information for each trunk module provisioned in an office.

This table identifies trunk modules that contains test circuits that terminate test pairs connected to RCS lines.

### Datafilling table TMINV (Sheet 1 of 3)

| Field  | Subfield or refinement | Entry                     | Explanation and action                                                                                                                          |
|--------|------------------------|---------------------------|-------------------------------------------------------------------------------------------------------------------------------------------------|
| TMNM   |                        | refer to subfields        | Trunk module number. Contains subfields TMTYPE and TMNO.                                                                                        |
|        | TMTYPE                 | TM8, MTM, OAU             | Trunk module type. Enter the trunk module type.                                                                                                 |
|        | TMNO                   | 0 to 2047, 0 to 255, or 0 | Trunk module number. Enter the trunk module number. Range for TM8: 0 to 2047. Range for MTM: 0 to 255. For an office alarm unit (OAU), enter 0. |
| FRTYPE |                        | TME                       | Frame type.                                                                                                                                     |
| FRNO   |                        | 0 to 511                  | Frame number. Enter the frame number of the TME frame.                                                                                          |



**Basic Call Processing** (continued)

Datafilling table TMINV (Sheet 2 of 3)

| Field  | Subfield or refinement | Entry                                        | Explanation and action                                                                                                                                                                                                                  |
|--------|------------------------|----------------------------------------------|-----------------------------------------------------------------------------------------------------------------------------------------------------------------------------------------------------------------------------------------|
| SHPOS  |                        | 0 to 77                                      | Shelf position. Enter the base mounting position of the trunk module (TM). Range for TM8: 04, 18, 32, 51, 65. For MTM, enter 65. For an OAU, enter 51.                                                                                  |
| FLOOR  |                        | 0 to 99                                      | Floor. Enter the number that represents the location of the trunk module.                                                                                                                                                               |
| ROW    |                        | A to Z, AA to ZZ, (except I and II, O or OO) | Row. Enter the row letter that represents the location of the trunk module.                                                                                                                                                             |
| FRPOS  |                        | 0 to 99                                      | Frame position. Enter the bay position of the TME frame.                                                                                                                                                                                |
| LKDATA |                        | refer to subfields                           | The C-side link data. For switches with the new enhanced network (ENET), this field contains subfields ENPAIR, ENSLOT, and ENLINK. For switches with the old junctured network (JNET), this field contains subfields NMPAIR and NMPORT. |
|        | NMPAIR                 | 0 to 31                                      | Network module pair number. Enter the network module number assigned to the trunk module.                                                                                                                                               |
|        | NMPORT                 | 0 to 63                                      | Network port number. Enter the network module port number assigned to the trunk module.                                                                                                                                                 |
|        | ENPAIR                 | 0 to 3                                       | Enet pair number. Enter the network pair number where the system assigns the PM.                                                                                                                                                        |
|        | ENSLOT                 | 10 to 16, 25 to 32                           | Enet slot number. Enter the crosspoint slot number where the PM is assigned.                                                                                                                                                            |
|        | ENLINK                 | 0 to 18                                      | Enet link number. Enter the crosspoint link where the PM is assigned.                                                                                                                                                                   |
| EQPEC  |                        | alphanumeric                                 | Equipment product engineering code. Enter the PEC of the trunk module.                                                                                                                                                                  |

## Basic Call Processing (continued)

### Datafilling table TMINV (Sheet 3 of 3)

| Field | Subfield or refinement | Entry                                           | Explanation and action                                                                 |
|-------|------------------------|-------------------------------------------------|----------------------------------------------------------------------------------------|
| LOAD  |                        | alphanumeric<br>(a maximum of eight characters) | Load. Enter the issue name of the PM software.                                         |
| EXECS |                        | alphanumeric                                    | Executive programs. Enter the set of executive programs required for the trunk module. |

### Datafill example for table TMINV

Sample datafill for table TMINV appear in the following example.

### MAP example for table TMINV

```

Table: TMINV

 TMNM FRTYPE FRNO SHPOS FLOOR ROW FRPOS LKDATA EQPEC LOAD
EXECS SCTMLOC

 TM8 0 TME 1 65 0 L 16 0 53 2X52AB BTMKA02
TM8EX N
 MTM 0 TME 0 18 0 L 16 0 53 2X52AC MTMKA02
MTMEX N
 MTM 1 TME 1 18 0 L 20 0 55 2X52AC MTMKA02
MTMEX

```

### Datafilling table TRKGRP

Datafill specific to Basic Call Processing for table TRKGRP appear in the following table. Only fields that apply to Basic Call Processing appear. For a description of the other fields, refer to the data schema section of this document.

Trunk group table (TRKGRP) contains data that customers define. This data is associated with each trunk group in the switching unit.

Each trunk group entry in table TRKGRP contains a different CLLI for the trunk group and other fields. The trunk group type (field GRPTYP) determines the entry. The trunk group type that applies to the SMS-R/RCS system is the maintenance and test trunk group (MAINT).

**Basic Call Processing** (continued)

This table identifies test circuits associated with the maintenance and test trunks.

**Datafilling table TRKGRP**

| Field                                                                                                                                                                                                                                                                                                                                                                 | Subfield or refinement | Entry                           | Explanation and action                                                                                                                                    |
|-----------------------------------------------------------------------------------------------------------------------------------------------------------------------------------------------------------------------------------------------------------------------------------------------------------------------------------------------------------------------|------------------------|---------------------------------|-----------------------------------------------------------------------------------------------------------------------------------------------------------|
| GRPKEY                                                                                                                                                                                                                                                                                                                                                                |                        | refer to subfields              | Group key. Contains subfield CLLI.                                                                                                                        |
|                                                                                                                                                                                                                                                                                                                                                                       | CLLI                   | alphanumeric                    | Common language location identifier. Enter code assigned in the CLLI table to the trunk group of the subgroup.                                            |
| GRPINFO                                                                                                                                                                                                                                                                                                                                                               |                        | refer to subfields              | Variable group data. When the trunk group type is MAINT, contains subfields GRPTYP, TRAFSNO, PADGRP, NCCLS, and CARD.                                     |
|                                                                                                                                                                                                                                                                                                                                                                       | GRPTYP                 | ITL2, TTL2, LOOPA, MAINT, SOCKT | Group type. Enter the group type for the trunk group.                                                                                                     |
|                                                                                                                                                                                                                                                                                                                                                                       | TRAFSNO                | 0 to 127                        | Traffic separation number. Maintenance and test trunks do not require this entry. Enter 0.                                                                |
|                                                                                                                                                                                                                                                                                                                                                                       | PADGRP                 | alphanumeric                    | Pad group. Enter the name of the pad group assigned to the trunk group in table PADDATA. For maintenance and test trunks, enter IAO (intraoffice trunks). |
|                                                                                                                                                                                                                                                                                                                                                                       | NCCLS                  | NCRT                            | A circuit class is not available.                                                                                                                         |
|                                                                                                                                                                                                                                                                                                                                                                       | CARD                   | alphanumeric                    | Card code. Enter the PEC of the maintenance and test trunk.                                                                                               |
| <p><b>Note 1:</b> Table TRKGRP contains a maximum of 2,047 trunk groups. The number of CLLIs available to name the trunk groups limits the current number.</p> <p><b>Note 2:</b> The set of trunk group types in a specified office is a function of the hardware and software features and feature packages. The operating company provides the office packages.</p> |                        |                                 |                                                                                                                                                           |

**Datafill example for table TRKGRP**

Sample datafill for table TRKGRP appear in the following example.

## Basic Call Processing (continued)

---

### MAP example for table TRKGRP

| Table: TRKGRP |       |    |     |      |         |
|---------------|-------|----|-----|------|---------|
| GRPKEY        |       |    |     |      | GRPINFO |
| -----         |       |    |     |      |         |
| HSET          | MAINT | 51 | IAO | NCRT | 5X30AA  |
| JACK          | MAINT | 52 | IAO | NCRT | 1X54AA  |
| LOOPA1        | LOOPA | 53 | TLD | NCRT | 2X75AA  |

### Datafilling table TRKSGRP

Trunk subgroup table (TRKSGRP) contains additional information. This information belongs to each subgroup assigned a trunk group that the trunk group (TRKGRP) table lists.

The system specifies input data for one or two subgroups for each trunk group in table TRKGRP. The system does not include subgroups that are MAINT group types.

**Note:** Trunk group datafill produces the trunk subgroup data for maintenance and test trunks. This datafill does not include subgroup 1 of trunk groups with code TTU.

Datafill specific to Basic Call Processing for table TRKSGRP appear in the following table. Only fields that apply to Basic Call Processing appear. For

**Basic Call Processing** (continued)

a description of the other fields, refer to the data schema section of this document.

**Datafilling table TRKSGRP (Sheet 1 of 3)**

| Field                                                                                                                                                                                                                                                                                                                                                                                                                                                                                                                                                                                                    | Subfield or refinement | Entry                             | Explanation and action                                                                                                                                                                       |
|----------------------------------------------------------------------------------------------------------------------------------------------------------------------------------------------------------------------------------------------------------------------------------------------------------------------------------------------------------------------------------------------------------------------------------------------------------------------------------------------------------------------------------------------------------------------------------------------------------|------------------------|-----------------------------------|----------------------------------------------------------------------------------------------------------------------------------------------------------------------------------------------|
| SGRPKEY                                                                                                                                                                                                                                                                                                                                                                                                                                                                                                                                                                                                  |                        | refer to subfields                | Subgroup key. Contains subfields CLLI and SGRP.                                                                                                                                              |
|                                                                                                                                                                                                                                                                                                                                                                                                                                                                                                                                                                                                          | CLLI                   | alphanumeric                      | Common language location identifier. Enter code assigned in table CLLI trunk group of the subgroup.                                                                                          |
|                                                                                                                                                                                                                                                                                                                                                                                                                                                                                                                                                                                                          | SGRP                   | 0 or 1                            | Subgroup number. Enter the number assigned to the trunk subgroup.                                                                                                                            |
| CARDCODE                                                                                                                                                                                                                                                                                                                                                                                                                                                                                                                                                                                                 |                        | alphanumeric                      | Card code. Enter the PEC of the maintenance and test trunk.                                                                                                                                  |
| SGRPVAR                                                                                                                                                                                                                                                                                                                                                                                                                                                                                                                                                                                                  |                        | refer to subfields                | Variable subgroup data. Standard signaling contains the following subfields: SIGDATA, DIR, OPULSTYP, OSTARTSG, IDGTIME, NUMSTOPS, CCONT, RNGBCK, ESUPR, SAT, REMBSY, DIALMODE, and TRKGDTIM. |
|                                                                                                                                                                                                                                                                                                                                                                                                                                                                                                                                                                                                          | SIGDATA                | STD                               | Signaling data. Enter the signaling code (STD for standard signaling).                                                                                                                       |
|                                                                                                                                                                                                                                                                                                                                                                                                                                                                                                                                                                                                          | DIR                    | IC, OG, or 2W                     | Direction. Enter trunk group direction, incoming (IC), outgoing (OG), or two-way (2W).                                                                                                       |
|                                                                                                                                                                                                                                                                                                                                                                                                                                                                                                                                                                                                          | OPULSTYP               | DP, DT, MF, MFC, NP, RP, or blank | Outgoing type of pulsing. Leave blank if trunk is incoming. (Note 1)                                                                                                                         |
| <p><b>Note 1:</b> If the code is TERM102T, subfields OPULSTYP and OSTARTSG are equal to MF and WK separately.</p> <p><b>Note 2:</b> If the code is SOCKT, subfield OSTARTSG is equal to IM.</p> <p><b>Note 3:</b> The system allocates memory for the number of trunk subgroups. The system allocates memory by the SIZE field in table DATASIZE. This memory is for the entry with field DATSKEY equal to TRKSGRP.</p> <p><b>Note 4:</b> The number of trunk subgroups is equal to twice the number of trunk groups.</p> <p><b>Note 5:</b> The maximum number of trunk subgroups assigned is 4 096.</p> |                        |                                   |                                                                                                                                                                                              |

**Basic Call Processing** (continued)

Datafilling table TRKSGRP (Sheet 2 of 3)

| Field                  | Subfield or refinement | Entry                                        | Explanation and action                                                                                                                                                                                                            |
|------------------------|------------------------|----------------------------------------------|-----------------------------------------------------------------------------------------------------------------------------------------------------------------------------------------------------------------------------------|
| SGRPVAR<br>(continued) | OSTARTSG               | DD, IM, GO, GS, LO, LS, SZ, WK, XD, or blank | Outgoing start dial signal. The trunk is outgoing or two-way. The outgoing pulse type is DP, MF, or DT. Enter the type of start dial signal the system requires. Leave subfield blank if trunk group is incoming. (Notes 1 and 2) |
|                        | IDGTIME                | 0 to 100, or blank                           | Interdigital timing. For maintenance and test trunks, enter 2.                                                                                                                                                                    |
|                        | NUMSTOPS               | 0 to 3, or blank                             | Number of stop/goes. For maintenance and test trunks, enter 0.                                                                                                                                                                    |
|                        | GLAREYD                | Y or N, or blank                             | Yield to glare. If the trunk group is two-way and the trunk subgroup is to yield to glare, enter Y. Or enter N. Leave blank if the trunk group is incoming or outgoing.                                                           |
|                        | CCONT                  | EI, IB, LN, MW, TR, 3W, or NO                | Coin control. The system arranges trunk subgroup for coin control. Enter the type of coin control required.                                                                                                                       |
|                        | RNGBCK                 | C6, C7_RING, EI, IB, LN, MW, SX, WK, or NO   | Ringback. The system arranges trunk subgroup for ring back signal. Enter the type of ring back signal required.                                                                                                                   |
|                        | ESUPR                  | F, H, or N                                   | Echo suppressor. For maintenance and test trunks, enter N (no echo suppressor).                                                                                                                                                   |
|                        | SAT                    | Y or N                                       | Satellite. If the system arranges trunk subgroup to switch by satellite, enter Y. For maintenance and test trunks, enter N (no satellite).                                                                                        |

**Note 1:** If the code is TERM102T, subfields OPULSTYP and OSTARTSG are equal to MF and WK separately.

**Note 2:** If the code is SOCKT, subfield OSTARTSG is equal to IM.

**Note 3:** The system allocates memory for the number of trunk subgroups. The system allocates memory by the SIZE field in table DATASIZE. This memory is for the entry with field DATSKEY equal to TRKSGRP.

**Note 4:** The number of trunk subgroups is equal to twice the number of trunk groups.

**Note 5:** The maximum number of trunk subgroups assigned is 4 096.

**Basic Call Processing** (continued)**Datafilling table TRKSGRP (Sheet 3 of 3)**

| <b>Field</b>                                                                                                                                                                                                                                                                                                                                                                                                                                                                                                                                                                                             | <b>Subfield or refinement</b> | <b>Entry</b>       | <b>Explanation and action</b>                                                                                                                                                                                                                                                                                                                                                                                             |
|----------------------------------------------------------------------------------------------------------------------------------------------------------------------------------------------------------------------------------------------------------------------------------------------------------------------------------------------------------------------------------------------------------------------------------------------------------------------------------------------------------------------------------------------------------------------------------------------------------|-------------------------------|--------------------|---------------------------------------------------------------------------------------------------------------------------------------------------------------------------------------------------------------------------------------------------------------------------------------------------------------------------------------------------------------------------------------------------------------------------|
| SGRPVAR<br>(continued)                                                                                                                                                                                                                                                                                                                                                                                                                                                                                                                                                                                   | REMBSY                        | Y or N             | Remote make busy. Enter Y if the system assigns trunk subgroup to the Remote Make Busy feature. Or enter N.                                                                                                                                                                                                                                                                                                               |
|                                                                                                                                                                                                                                                                                                                                                                                                                                                                                                                                                                                                          | DIALMODE                      | C, M, or blank     | Dial mode. If the trunk subgroup is incoming or two-way, enter C if digits start from a customer. Or, enter M if the incoming digits are machine produced. For maintenance and test trunks, this subfield is blank.                                                                                                                                                                                                       |
|                                                                                                                                                                                                                                                                                                                                                                                                                                                                                                                                                                                                          | TRKGDTIM                      | 1 to 255, or blank | Trunk guard timing. If the trunk group is outgoing or two-way, enter the time, in 10 ms intervals, that the trunk waits. The trunk waits after the on hook signal transfers to the far end. The trunk is put in idle queue. For maintenance and test trunks, enter 16. The number 16 is for the 160 ms elapsed time interval. This interval occurs before the trunk returns to the idle link list after trunk disconnect. |
| <p><b>Note 1:</b> If the code is TERM102T, subfields OPULSTYP and OSTARTSG are equal to MF and WK separately.</p> <p><b>Note 2:</b> If the code is SOCKT, subfield OSTARTSG is equal to IM.</p> <p><b>Note 3:</b> The system allocates memory for the number of trunk subgroups. The system allocates memory by the SIZE field in table DATASIZE. This memory is for the entry with field DATSKEY equal to TRKSGRP.</p> <p><b>Note 4:</b> The number of trunk subgroups is equal to twice the number of trunk groups.</p> <p><b>Note 5:</b> The maximum number of trunk subgroups assigned is 4 096.</p> |                               |                    |                                                                                                                                                                                                                                                                                                                                                                                                                           |

**Datafill example for table TRKSGRP**

Sample datafill for table TRKSGRP appear in the following example.

**Basic Call Processing** (continued)

**MAP example for table TRKSGRP**

```

Table: TRKSGRP

SGRPKEY CARDCODE

HSET 0 5X30AA
 STD OG NP WK 0 0 NO NO N N N 17 UNEQ
JACK 0 1X54AA
 STD OG NP WK 0 0 NO NO N N N 17 UNEQ
LOOPA1 0 2X75AA
 STD OG NP IM 0 0 NO NO N N N 17 UNEQ

```

**Datafilling table TRKMEM**

The trunk member table (TRKMEM) lists data. This data associates with each trunk assigned to the trunk groups and subgroups. Tables TRKGRP and TRKSGRP specifies these groups and subgroups.

This table identifies circuits associated with test equipment. The equipment tests lines and trunks.

Datafill specific to Basic Call Processing for table TRKMEM appear in the following table. Only fields that apply to Basic Call Processing appear. For a description of the other fields, refer to the data schema section of this document.

**Datafilling table TRKMEM (Sheet 1 of 2)**

| Field                                                                                                                                                                                                                                                                                                              | Subfield or refinement | Entry                             | Explanation and action                                                                                                        |
|--------------------------------------------------------------------------------------------------------------------------------------------------------------------------------------------------------------------------------------------------------------------------------------------------------------------|------------------------|-----------------------------------|-------------------------------------------------------------------------------------------------------------------------------|
| CLLI                                                                                                                                                                                                                                                                                                               |                        | alphanumeric (1 to 16 characters) | Common language location identifier. Enter the code assigned in table CLLI to the trunk group of which the trunk is a member. |
| EXTRKNM                                                                                                                                                                                                                                                                                                            |                        | 0 to 9999                         | External trunk number. Enter the external trunk number assigned to the trunk.                                                 |
| SGRP                                                                                                                                                                                                                                                                                                               |                        | 0 or 1                            | Subgroup number. Enter the subgroup number where the system assigns the trunk.                                                |
| <p><b>Note 1:</b> The system allocates memory for the total number of trunks. These trunks are specified in field TRKGRSIZ in table CLLI for the correct trunk groups.</p> <p><b>Note 2:</b> Current data can increase table size. The data changes field TRKGRSIZ in table CLLI for the correct trunk groups.</p> |                        |                                   |                                                                                                                               |



**Basic Call Processing** (continued)**Datafilling table TRKMEM (Sheet 2 of 2)**

| Field  | Subfield or refinement | Entry              | Explanation and action                                                                                              |
|--------|------------------------|--------------------|---------------------------------------------------------------------------------------------------------------------|
| MEMVAR |                        | refer to subfields | Variable data for members. For SMS-R/RCS, contains subfields PMTYPE, TMNO, and TMCKTNO.                             |
|        | PMTYPE                 | alphanumeric       | PM type. Enter the PM type where the system mounts the trunk.                                                       |
|        | TMNO                   | 0 to 2047          | Trunk module number. Enter the number assigned to the trunk module where the system assigns the trunk group member. |
|        | TMCKTNO                | 0 to 29            | Trunk module circuit number. Enter the trunk module circuit number where the system assigns the trunk group member. |

**Note 1:** The system allocates memory for the total number of trunks. These trunks are specified in field TRKGRSIZ in table CLLI for the correct trunk groups.

**Note 2:** Current data can increase table size. The data changes field TRKGRSIZ in table CLLI for the correct trunk groups.

**Datafill example for table TRKMEM**

Sample datafill for table TRKMEM appear in the following example.

**MAP example for table TRKMEM**

| Table: TRKMEM |         |      |        |   |    |
|---------------|---------|------|--------|---|----|
| CLLI          | EXTRKNM | SGRP | MEMVAR |   |    |
| HSET          | 0       | 0    | TM8    | 0 | 12 |
| LTU           | 1000    | 0    | MTM    | 1 | 14 |
| MONTALK       | 1000    | 0    | TM8    | 0 | 0  |

**Datafilling table TRKMEM**

The trunk member table (TRKMEM) lists data that associates with each trunk assigned to trunk groups and subgroups. Tables TRKGRP and TRKSGRP specify these trunk groups and subgroups.

This table identifies circuits that associates with test equipment used to test lines and trunks.

## Basic Call Processing (continued)

The following table shows the datafill for Basic Call Processing for table TRKMEM. The fields that apply to Basic Call Processing appear. Refer to the data schema section of this document for a description of the other fields.

### Datafilling table TRKMEM

| Field                                                                                                                                                                                                                                                                                                 | Subfield or refinement | Entry                             | Explanation and action                                                                                                        |
|-------------------------------------------------------------------------------------------------------------------------------------------------------------------------------------------------------------------------------------------------------------------------------------------------------|------------------------|-----------------------------------|-------------------------------------------------------------------------------------------------------------------------------|
| CLLI                                                                                                                                                                                                                                                                                                  |                        | alphanumeric (1 to 16 characters) | Common language location identifier. Enter the code assigned in table CLLI to the trunk group of which the trunk is a member. |
| EXTRKNM                                                                                                                                                                                                                                                                                               |                        | 0 to 9999                         | External trunk number. Enter the external trunk number assigned to the trunk.                                                 |
| SGRP                                                                                                                                                                                                                                                                                                  |                        | 0 or 1                            | Subgroup number. Enter the subgroup number where the trunk is assigned.                                                       |
| MEMVAR                                                                                                                                                                                                                                                                                                |                        | refer to subfields                | Variable data for members. For SMS-R/RCS, contains subfields PMTYPE, TMNO and TMCKTNO.                                        |
|                                                                                                                                                                                                                                                                                                       | PMTYPE                 | alphanumeric                      | PM type. Enter the PM type that contains the trunk.                                                                           |
|                                                                                                                                                                                                                                                                                                       | TMNO                   | 0 to 2047                         | Trunk module number. Enter the number assigned to the trunk module where the trunk group member is assigned.                  |
|                                                                                                                                                                                                                                                                                                       | TMCKTNO                | 0 to 29                           | Trunk module circuit number. Enter the trunk module circuit number where the trunk group member is assigned.                  |
| <p><b>Note 1:</b> The system allocates memory for the total number of trunks that field TRKGRSIZ in table CLLI specifies for the correct trunk groups.</p> <p><b>Note 2:</b> Table size can increase with data present when you change field TRKGRSIZ in table CLLI for the correct trunk groups.</p> |                        |                                   |                                                                                                                               |

### Datafill example for table TRKMEM

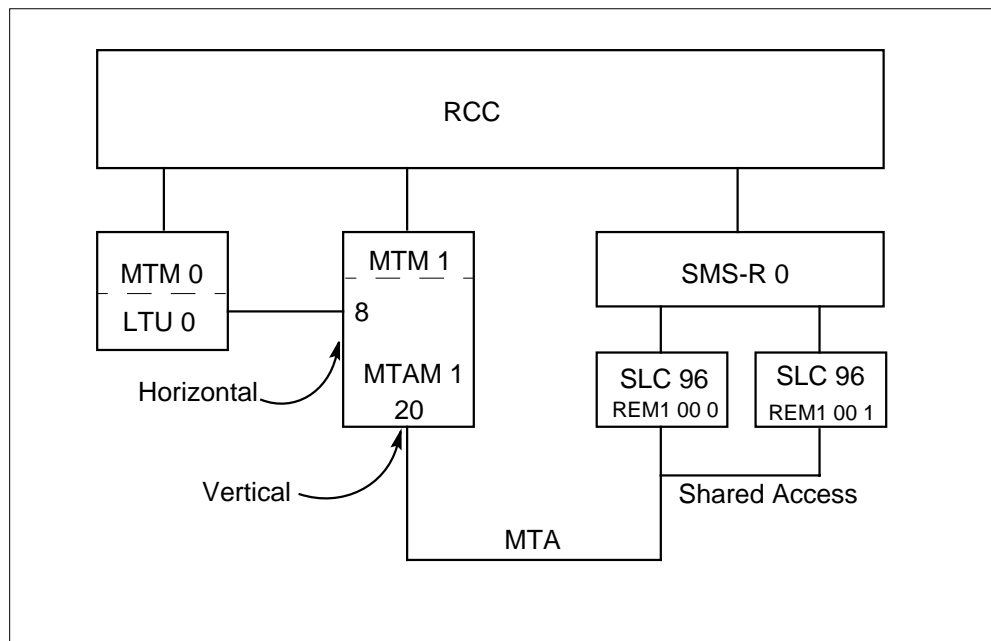
Sample datafill for table TRKMEM appears in the following example.

## Basic Call Processing (continued)

### MAP example for table TRKMEM

| Table: TRKMEM |         |      |        |   |    |
|---------------|---------|------|--------|---|----|
| CLLI          | EXTRKNM | SGRP | MEMVAR |   |    |
| HSET          | 0       | 0    | TM8    | 0 | 12 |
| LTU           | 1000    | 0    | MTM    | 1 | 14 |
| MON TALK      | 1000    | 0    | TM8    | 0 | 0  |

### Example MTA configuration



### Datafilling table ALMSCGRP

The alarm scan group table (ALMSCGRP) records the circuit equipment, location and type of card. The ALMSCGRP serves as a head table for the scan points.

Before you assign a scan group to this table, make sure the following tables do not have the scan group assigned:

- scan group table (SCGRP)
- network management scan tables (NWMSC or NWMSCPT)

**Basic Call Processing** (continued)

The datafill for Basic Call Processing for table ALMSCGRP appears in the following table. The fields that apply to Basic Call Processing appear. Refer to the data schema section of this document for a description of the other fields.

**Datafilling table ALMSCGRP**

| Field    | Subfield or refinement | Entry                                          | Explanation and action                                                                                          |
|----------|------------------------|------------------------------------------------|-----------------------------------------------------------------------------------------------------------------|
| SCGROUP  |                        | 0 to 255                                       | Scan group. Enter the scan group number.                                                                        |
| TMTYPE   |                        | ATM, CTM, DTM, ISM, MTM, OAU, RMM, RSM, TM8    | Trunk module type. Enter the type of trunk module that contains the circuit.                                    |
| TMNO     |                        | 0 to 2047                                      | Trunk module number. Enter the number of the trunk module that contains the circuit. If TMTYPE is OAU, enter 0. |
| TMCKTNO  |                        | 0 to 29                                        | Trunk module circuit number. Enter the trunk module circuit number where the circuit is assigned.               |
| CARDCODE |                        | 3X82AA, 3X82AB, 3X83AA, 3X84AA, 3X85AA, 0X10AA | Product engineering code (PEC). Enter the PEC of the alarm card.                                                |

**Datafill example for table ALMSCGRP**

Sample datafill for table ALMSCGRP appears in the following example.

**MAP example for table ALMSCGRP**

Table: ALMSCGRP

| SCGROUP | TMTYPE | TMNO | TMCKTNO | CARDCODE |
|---------|--------|------|---------|----------|
| 0       | MTM    | 0    | 1       | 3X82AA   |
| 1       | MTM    | 4    | 1       | 3X82AA   |
| 2       | MTM    | 0    | 5       | 3X83AA   |
| 3       | MTM    | 0    | 7       | 3X85AA   |
| 4       | MTM    | 0    | 8       | 0X10AA   |
| 5       | MTM    | 0    | 9       | 0X10AA   |

**Basic Call Processing** (continued)**Datafilling table ALMSDGRP**

The alarm signal distribution group table (ALMSDGRP) records the circuit equipment, location and type of card. The ALMSDGRP serves as a head table for the correct SD points.

Before you assign an SD group to this table, make sure the SD group was not assigned to either of the following tables:

- the signal distribution table (SDGRP)
- the network management signal distribution tables (NWMSD and NWMSDPT)

The following table shows the datafill for Basic Call Processing for table ALMSDGRP. The fields that apply to Basic Call Processing appear. Refer to the data schema section of this document for a description of the other fields.

**Datafilling table ALMSDGRP**

| Field    | Subfield or refinement | Entry                                                     | Explanation and action                                                                                                                           |
|----------|------------------------|-----------------------------------------------------------|--------------------------------------------------------------------------------------------------------------------------------------------------|
| SDGROUP  |                        | 0 to 255                                                  | Signal distribution group. Enter the signal distribution group number.                                                                           |
| TMTYPE   |                        | ATM, CTM, DTM, ISM, MTM, OAU, RSM, RMM, STM, TM8          | Trunk module type. Enter the type of trunk module that contains the circuit.                                                                     |
| TMNO     |                        | 0 to 2047                                                 | Trunk module number. Enter the number of the trunk module that contains the circuit. If TMTYPE is OAU, enter 0. Range if TMTYPE is MTM: 0 to 255 |
| TMCKTNO  |                        | 0 to 29                                                   | Trunk module circuit number. Enter the trunk module circuit number where the circuit is assigned.                                                |
| CARDCODE |                        | 3X82AA, 3X82AB, 3X83AA, 3X84AA, 3X85AA, 2X55AA, or 2X57AA | Product engineering code. Enter the PEC of the alarm card.                                                                                       |

**Basic Call Processing** (continued)

**Datafill example for table ALMSDGRP**

Sample datafill for table ALMSDGRP appears in the following table.

**MAP example for table ALMSDGRP**

Table: ALMSDGRP

| SDGROUP | TMTYPE | TMNO | TMCKTNO | CARDCODE |
|---------|--------|------|---------|----------|
| 0       | MTM    | 0    | 1       | 3X82AB   |
| 1       | MTM    | 4    | 1       | 3X82AB   |
| 2       | MTM    | 0    | 5       | 3X84AA   |
| 3       | MTM    | 0    | 7       | 2X57AA   |
| 4       | MTM    | 0    | 8       | 2X57AA   |

**Datafilling table ALMSD**

The alarm signal distribution point table (ALMSD) identifies the function that each assigned SD point in the alarm signal distribution groups performs.

The table that points to ALMSD is the alarm signal distribution group table (ALMSDGRP).

The datafill for Basic Call Processing for table ALMSD appears in the following table. The fields that apply to Basic Call Processing appear. Refer to the data schema section of this document for a description of the other fields.

**Datafilling table ALMSD (Sheet 1 of 2)**

| Field    | Subfield or refinement | Entry                                     | Explanation and action                                                                                                                                                    |
|----------|------------------------|-------------------------------------------|---------------------------------------------------------------------------------------------------------------------------------------------------------------------------|
| FUNCTION |                        | alphanumeric (a maximum of 16 characters) | Function. Enter the alarm function.                                                                                                                                       |
| SDGROUP  |                        | 0 to 255                                  | Signal distribution group. Enter the signal distribution group number where the SD point belongs.                                                                         |
| POINT    |                        | 0 to 7                                    | Signal distribution point. Enter the signal distribution point number in the SD group.                                                                                    |
| NORMALST |                        | 0 to 1                                    | Normal state. Enter the normal state of the signal distribution point. Enter 0 if the SD point is normally off or open. Enter 1 if the SD point is normally on or closed. |

**Basic Call Processing** (continued)**Datafilling table ALMSD (Sheet 2 of 2)**

| Field    | Subfield or refinement | Entry  | Explanation and action                                                                                                          |
|----------|------------------------|--------|---------------------------------------------------------------------------------------------------------------------------------|
| AUDIBLE  |                        | Y or N | Audible. Enter Y if the SD point is reset when the audible alarm reset key operates. When the SD point does not reset, enter N. |
| LAMPTEST |                        | Y or N | Lamp test. Enter Y when the lamp test includes the SD point. When the SD point does not enter the SD point, enter N.            |

**Datafill example for table ALMSD**

Sample datafill for table ALMSD appears in the following example.

**MAP example for table ALMSD**

| Table: ALMSD |         |       |          |         |          |
|--------------|---------|-------|----------|---------|----------|
| FUNCTION     | SDGROUP | POINT | NORMALST | AUDIBLE | LAMPTEST |
| EXPILPWR     | 2       | 6     | 0        | N       | N        |

**Datafilling table ALMSC**

The alarm scan table (ALMSC) identifies the function that each assigned scan point in the alarm scan groups performs. The table that points to ALMSC is the alarm scan group table (ALMSCGRP).

The datafill for Basic Call Processing for table ALMSC appears in the following table. The fields that apply to Basic Call Processing appear. Refer to the data schema section of this document for a description of the other fields.

**Datafilling table ALMSC (Sheet 1 of 2)**

| Field    | Subfield or refinement | Entry                                              | Explanation and action                                                |
|----------|------------------------|----------------------------------------------------|-----------------------------------------------------------------------|
| FUNCTION |                        | alphanumeric<br>(a maximum<br>of 16<br>characters) | Function. Enter the alarm function.                                   |
| SCGROUP  |                        | 0 to 255                                           | Scan group. Enter the scan group number where the scan point belongs. |

**Basic Call Processing** (continued)

Datafilling table ALMSC (Sheet 2 of 2)

| Field    | Subfield or refinement | Entry              | Explanation and action                                                                                                                                                                                                            |
|----------|------------------------|--------------------|-----------------------------------------------------------------------------------------------------------------------------------------------------------------------------------------------------------------------------------|
| POINT    |                        | 0 to 6             | Scan point. Enter the scan point number in the scan group.                                                                                                                                                                        |
| NORMALST |                        | 0 to 1             | Normal state. Enter the normal state of the scan point. Enter 0 if the scan point is normally off or open. Enter 1 if the scan point is normally on or closed.                                                                    |
| REPORT   |                        | Y or N             | Report. Enter Y if an alarm report is logged. Enter N if an alarm report is not logged.                                                                                                                                           |
| ALM      |                        | CR, MJ, MN, or NA  | Alarm. Enter the type of alarm to activate: <ul style="list-style-type: none"> <li>• critical (CR)</li> <li>• major (MJ)</li> <li>• minor (MN)</li> <li>• no alarm (NA)</li> </ul>                                                |
| LOGIC    |                        | refer to subfields | Logic. Contains of subfields FIX_LOGIC, SDFUNCT, ALMGRP and ALMXFR.                                                                                                                                                               |
|          | FIX_LOGIC              | Y or N             | Fix logic. Enter Y if the logic that associates with the function is fixed. Enter N if the logic is not fixed.                                                                                                                    |
|          | SDFUNCT                | alphanumeric       | Signal distribution function. Enter the SD function or functions that associate with a specified scan point.                                                                                                                      |
|          | ALMGRP                 | Y or N             | Alarm grouping. Enter Y to cause the alarm function when activation of the alarm grouping key occurs. Enter N to cause the alarm function at all times. The alarm grouping key does not affect alarm function in this occurrence. |
|          | ALMXFR                 | Y or N             | Alarm transfer. Enter Y to cause the alarm function when the alarm transfer key activates. Enter N for any other condition.                                                                                                       |

**Datafill example for table ALMSC**

Sample datafill for table ALMSC appears in the following example.



**Basic Call Processing** (continued)**MAP example for table ALMSC**

| Table: ALMSC |         |       |          |        |                                                                   |       |
|--------------|---------|-------|----------|--------|-------------------------------------------------------------------|-------|
| FUNCTION     | SCGROUP | POINT | NORMALST | REPORT | ALM                                                               | LOGIC |
| ABMTMFL      | 0       | 0     | 0        | Y      | MJ N(ABOUAU N N) (ABAUD N N)<br>(OAUVISLOOP N N)<br>(MJXFR N Y)\$ |       |

**Datafilling table SCGRP**

The scan group table (SCGRP) lists the PEC and location at the host or remote switching units for scan groups. These scan groups are reserved as scan points for line features.

The locations of scan groups assigned for line features cannot be assigned to alarm or network management scan groups.

The datafill for Basic Call Processing for table SCGRP appears in the following table. The fields that apply to Basic Call Processing appear. Refer to the data schema section of this document for a description of the other fields.

**Datafilling table SCGRP**

| Field    | Subfield or refinement | Entry           | Explanation and action                                                                                                               |
|----------|------------------------|-----------------|--------------------------------------------------------------------------------------------------------------------------------------|
| SCGRPNO  |                        | 0 to 511        | Scan group. Enter the scan group number.                                                                                             |
| TMTYPE   |                        | MTM, RSM or RMM | Trunk module type. Enter the type of trunk module that contains the miscellaneous scan card, MTM or remote maintenance module (RMM). |
| TMNO     |                        | 0 to 2047       | Trunk module number. Enter the number assigned to the MTM or RMM that contains the miscellaneous scan card.                          |
| TMCKTNO  |                        | 0 to 29         | Trunk module circuit number. Enter the trunk module circuit number on the MTM or RMM where the scan group is assigned.               |
| CARDCODE |                        | 0X10AA          | Product engineering code. Enter the PEC of the scan card.                                                                            |

**Datafill example for table SCGRP**

Sample datafill for table SCGRP appears in the following example.

## Basic Call Processing (continued)

### MAP example for table SCGRP

| Table: SCGRP |        |      |         |          |
|--------------|--------|------|---------|----------|
| SCGRPNO      | TMTYPE | TMNO | TMCKTNO | CARDCODE |
| 0            | MTM    | 3    | 8       | 0X10AA   |
| 1            | MTM    | 3    | 9       | 0X10AA   |

### Datafilling table SDGRP

The signal distribution group table (SDGRP) lists the PEC and location at the host or remote switching units for the SD groups. The SD groups are reserved as SD points for line features.

The locations of SD groups assigned for line features cannot be assigned to alarm or network management SD groups.

The datafill for Basic Call Processing for table SDGRP appears in the following table. The fields that apply to Basic Call Processing appear. Refer to the data schema section of this document for a description of the other fields.

### Datafilling table SDGRP

| Field    | Subfield or refinement | Entry           | Explanation and action                                                                                               |
|----------|------------------------|-----------------|----------------------------------------------------------------------------------------------------------------------|
| SDGRPNO  |                        | 0 to 511        | Signal distribution group. Enter the SD group number.                                                                |
| TMTYPE   |                        | MTM, RMM or RSM | Trunk module type. Enter the type of trunk module that contains the SD card, MTM or RMM.                             |
| TMNO     |                        | 0 to 2047       | Trunk module number. Enter the number assigned to the MTM or RMM that contains the SD card.                          |
| TMCKTNO  |                        | 0 to 29         | Trunk module circuit number. Enter the trunk module circuit number on the MTM or RMM where the SD group is assigned. |
| CARDCODE |                        | 2X57AA          | Product engineering code. Enter the PEC of the SD card.                                                              |

### Datafill example for table SDGRP

Sample datafill for table SDGRP appears in the following example.

**Basic Call Processing** (continued)**MAP example for table SDGRP**

| Table: SDGRP |        |      |         |          |
|--------------|--------|------|---------|----------|
| SDGRPNO      | TMTYPE | TMNO | TMCKTNO | CARDCODE |
| 0            | MTM    | 0    | 14      | 2X57AA   |
| 1            | MTM    | 0    | 15      | 2X57AA   |
| 2            | RSM    | 0    | 14      | 2X57AA   |
| 3            | RSM    | 0    | 15      | 2X57AA   |

**Datafilling table LNINV**

Table LNINV contains an inventory of subscriber lines and associated line cards for RCS modules.

To accommodate RCS lines, table LNINV and the circuit locate (CKTLOC) command change. The LEN format do not change.

The user enters RCS lines in table LNINV. The fields do not change for RCS lines, CARDCODE. The following card codes increase the range of values for this field:

- SCD203 for single-party lines
- SCD221 for multiparty lines
- SCD233 for coin lines
- SCD271 for a special plain ordinary telephone service (SPOTS) card used as a single-party plain ordinary telephone service (POTS) card
- SCDFSR for FSR

**LEN format**

The LEN format corresponds to the characteristics of line modules. The line modules have 20 drawers with 32 line circuits for each drawer. There are two line modules to a frame (double-bay line module). In an RCS the LEN format do not change, but some field ranges change. Use of logical (software related) to mapping of LEN to location occurs. This mapping allows use of current administration forms and software entries.

## Basic Call Processing (continued)

The LEN represents administration software entries only. The LEN does not require analog line interface circuits. The LEN format contains the following:

- Site describes the location of peripherals, inside (host) or outside (remote site name) the central office. Four alphanumeric characters identify the site.
- Frame is a logical unit that associates with one or more RCS modules. The range is 0 to 99
- Unit is the RCS. You can allocate a maximum of ten RCS units to the same logical frame. The range is 0 to 9
- Drawer is one of the four RCS shelves and each drawer contains 12 line cards that connect to one or two subscriber lines. The range is 0 to 3
- Circuit is the line circuit number in the line card. Single-circuit line cards use even-numbered circuits. The range is 0 to 23

Refer to the following Software mapping of RCS line circuits and Physical location of RCS line circuits figures. The logical (software associated) to mapping of RCS LEN numbers appears in these figures.

### Software mapping of RCS line circuits

|        |   | Slot |   |   |   |   |    |    |    |    |    |    |    |
|--------|---|------|---|---|---|---|----|----|----|----|----|----|----|
|        |   | 5    | 6 | 7 | 8 | 9 | 10 | 11 | 12 | 13 | 14 | 15 | 16 |
| Drawer | 3 | 0    | 2 | 4 | 6 | 8 | 10 | 12 | 14 | 16 | 18 | 20 | 22 |
|        |   | 1    | 3 | 5 | 7 | 9 | 11 | 13 | 15 | 17 | 19 | 21 | 23 |
|        | 2 | 0    | 2 | 4 | 6 | 8 | 10 | 12 | 14 | 16 | 18 | 20 | 22 |
|        |   | 1    | 3 | 5 | 7 | 9 | 11 | 13 | 15 | 17 | 19 | 21 | 23 |
|        | 1 | 0    | 2 | 4 | 6 | 8 | 10 | 12 | 14 | 16 | 18 | 20 | 22 |
|        |   | 1    | 3 | 5 | 7 | 9 | 11 | 13 | 15 | 17 | 19 | 21 | 23 |
|        | 0 | 0    | 2 | 4 | 6 | 8 | 10 | 12 | 14 | 16 | 18 | 20 | 22 |
|        |   | 1    | 3 | 5 | 7 | 9 | 11 | 13 | 15 | 17 | 19 | 21 | 23 |

**Basic Call Processing** (continued)**Physical location of RCS line circuits**

|       |   | Slot |   |   |   |    |    |    |    |    |    |    |    |    |    |    |    |
|-------|---|------|---|---|---|----|----|----|----|----|----|----|----|----|----|----|----|
|       |   | 1    | 2 | 3 | 4 | 5  | 6  | 7  | 8  | 9  | 10 | 11 | 12 | 13 | 14 | 15 | 16 |
| Shelf | D |      |   |   |   | 73 | 75 | 77 | 79 | 81 | 83 | 85 | 87 | 89 | 91 | 93 | 95 |
|       |   |      |   |   |   | 74 | 76 | 78 | 80 | 82 | 84 | 86 | 88 | 90 | 92 | 94 | 96 |
|       | C |      |   |   |   | 49 | 51 | 53 | 55 | 57 | 59 | 61 | 63 | 65 | 67 | 69 | 71 |
|       |   |      |   |   |   | 50 | 52 | 54 | 56 | 58 | 60 | 62 | 64 | 66 | 68 | 70 | 72 |
|       | B |      |   |   |   | 25 | 27 | 29 | 31 | 33 | 35 | 37 | 39 | 41 | 43 | 45 | 47 |
|       |   |      |   |   |   | 26 | 28 | 30 | 32 | 34 | 36 | 38 | 40 | 42 | 44 | 46 | 48 |
|       | A |      |   |   |   | 1  | 3  | 5  | 7  | 9  | 11 | 13 | 15 | 17 | 19 | 21 | 23 |
|       |   |      |   |   |   | 2  | 4  | 6  | 8  | 10 | 12 | 14 | 16 | 18 | 20 | 22 | 24 |

The CKTLOC command helps operating company personnel locate the shelf slot of a line. The CKTLOC is available at the line test position (LTP) level of the MAP terminal.

When operating company personnel enter CKTLOC, the MAP display shows the LEN for that circuit. An example of a CKTLOC entry is CKTLOC 18. The shelf that corresponds to the drawer and the slot and PEC of the line card appear. The CKTLOC shows operating company personnel the shelf and slot location for a particular line circuit.

**Physical and logical mapping of line circuits**

For line modules, each line circuit associates with one line card. For the RCS, each RCS line card contains one or two line circuits.

A line card for coin lines has one line circuit. A single- or multiparty line card has two line circuits. Single-circuit line cards use even-numbered circuit values, as assigned in the LEN. Subscriber lines that associates with these circuits are assigned to odd- or even-numbered DS-1 channels.

In mode II, coin line cards are in the four slots to the far right on each shelf.

## Basic Call Processing (continued)

---

The Software mapping of RCS line circuits and Physical location of RCS line circuits figures are on the preceding page. This information describes the logical and physical mapping of line circuits.

The Software mapping of RCS line circuits figure shows drawers that contain 12 slots. These slots contain line cards that support datafilled lines. Four slots do not appear. These slots correspond to the slots that hold common control cards. The last eight lines of each drawer are entered as not equipped. This action causes the drawers to look like shelves.

The Physical location of RCS line circuits figure shows line circuits, numbered 1 to 96. Each box represents a line card. Sixteen slots form a shelf and two shelves (A and B or C and D) form a shelf group. The four slots to the far left of all shelves contain common control cards. The remaining 12 slots on each shelf contain line cards.

The following examples demonstrate the software-to-physical line circuit relationship.

- LEN: REM2 00 0 0 23 has a software location of drawer 0, circuit 23. The REM2 00 0 0 23 is in shelf A, slot 16.
- LEN: REM2 00 0 1 05 has a software location of drawer 1, circuit 5. The REM2 00 0 1 05 is in shelf B, slot 7.

The RCS lines follow the current LEN format, but problems occur when an attempt to locate the slot of a line occurs. The RCS uses line cards that contain one or two lines. The CKTLOC command changes to accommodate the following:

- the difference between logical and physical labeling of shelves
- the logical and physical labeling of line circuits

**Basic Call Processing** (continued)**LNINV datafill procedure**

The following table shows the datafill for Basic Call Processing for table LNINV. The fields that apply to Basic Call Processing appear. Refer to the data schema section of this document for a description of the other fields.

**Datafilling table LNINV (Sheet 1 of 4)**

| <b>Field</b> | <b>Subfield or refinement</b> | <b>Entry</b>       | <b>Explanation and action</b>                                                                                                                                                                                                                                                                     |
|--------------|-------------------------------|--------------------|---------------------------------------------------------------------------------------------------------------------------------------------------------------------------------------------------------------------------------------------------------------------------------------------------|
| LEN          |                               | refer to subfields | Line equipment number. Contains subfields SITE, FRAME, UNIT, LSG and CIRCUIT                                                                                                                                                                                                                      |
|              | SITE                          | alphanumeric       | Site. Enter the location of the RCS. This entry is not optional. There is no default value assigned to this entry.                                                                                                                                                                                |
|              | FRAME                         | 0 to 511           | Frame. Enter the remote concentrator module frame number, which is not a physical frame. This module frame number is a software entity that identifies the RCS modules that share the same metallic test pair. All RCS modules that share the same metallic test pair have the same frame number. |
|              | UNIT                          | 0 to 9             | Unit. Enter the remote concentrator module unit number.                                                                                                                                                                                                                                           |
|              | LSG                           | 0 to 3             | Line subgroup. Enter the line subgroup of the RCS where the line is assigned.                                                                                                                                                                                                                     |
|              | CIRCUIT                       | 0 to 23            | LINE card circuit number. Enter the line card circuit number of the line subgroup where the card is assigned.                                                                                                                                                                                     |

**Basic Call Processing** (continued)

Datafilling table LNINV (Sheet 2 of 4)

| Field    | Subfield or refinement | Entry                                                         | Explanation and action                                                                                                                                                                                                                                                                                                                                                                                                                                                                                                                                                                                                                                                                                                                                                                                                                                                                                                                                                                                                                                                                                                              |
|----------|------------------------|---------------------------------------------------------------|-------------------------------------------------------------------------------------------------------------------------------------------------------------------------------------------------------------------------------------------------------------------------------------------------------------------------------------------------------------------------------------------------------------------------------------------------------------------------------------------------------------------------------------------------------------------------------------------------------------------------------------------------------------------------------------------------------------------------------------------------------------------------------------------------------------------------------------------------------------------------------------------------------------------------------------------------------------------------------------------------------------------------------------------------------------------------------------------------------------------------------------|
| CARDCODE |                        | SCD203,<br>SCD221,<br>SCD233,<br>SCD271,<br>SCDFSR,<br>NAILUP | <p>Card code. Enter the PEC of the line card. Refer to the following notes for the range.</p> <p><b>Note:</b> Multipart cards are not used in an RCS set up for FSR. The user can enter An SCD221 card code in table LNINV for line cards on an RCS that has FSR entered. When this entry occurs, the following error message appears:</p> <p>SCD221 IS NOT VALID FOR RCS WITH FSR<br/>RNGTYPE</p> <p><b>Note 1:</b> Datafill SCD222 900 Ω and SCD252 1500 Ω FSR cards as SCDFSR for frequency selective ringing.</p> <p><b>Note 2:</b> The user can enter the SCDFSR card code in table LNINV for line cards on an RCS. The RCS has S entered in the RNGTYPE field of table RCSINV. When this entry occurs, the following error message appears:</p> <p>SCDFSR IS NOT VALID FOR RCS WITH<br/>SUPERIMPOSED RNGTYPE</p> <p><b>Note:</b> The SPOTS card is for single-party or special services. When used for special services, the user must enter the SPOTS card as NAILUP. The user must enter both circuits in the SPOTS card as loop start or ground start. Enter the GND field Y for both circuits or N for both circuits.</p> |



**Basic Call Processing** (continued)

Datafilling table LNINV (Sheet 3 of 4)

| Field                   | Subfield or refinement | Entry                                                     | Explanation and action                                                                                                                                                                                                                                                                                                                                                                                                                                                                                                                                                                                                                       |
|-------------------------|------------------------|-----------------------------------------------------------|----------------------------------------------------------------------------------------------------------------------------------------------------------------------------------------------------------------------------------------------------------------------------------------------------------------------------------------------------------------------------------------------------------------------------------------------------------------------------------------------------------------------------------------------------------------------------------------------------------------------------------------------|
| CARDCODE<br>(continued) |                        |                                                           | <p><b>Note 1:</b> Do not enter SPOTS cards in a mode III RCS. Equipment in mode III multiplexes 48 time slots on to two DS-1 lines. Equipment in mode III expects only single-circuit cards. When the user enters SPOTS cards, only even-numbered circuits for the cards are used.</p> <p><b>Note 2:</b> You can change from an SCD233 coin card to an SCD203 POTS card or to an SCD271 SPOTS card. Make sure the even and odd circuits on the same line card have the same cardcode. Before you change the CARDCODE field, delete the odd circuit. You must also change the CARDCODE field in the even circuit and add the odd circuit.</p> |
| PADGRP                  |                        | alphanumeric                                              | Pad group. Enter the name of the pad group assigned to the line circuit in the table PADATA.                                                                                                                                                                                                                                                                                                                                                                                                                                                                                                                                                 |
| STATUS                  |                        | HASU,<br>WORKING,<br>CUTOFF,<br>RESERVED or<br>UNEQUIPPED | Status. Enter the line inventory availability status.                                                                                                                                                                                                                                                                                                                                                                                                                                                                                                                                                                                        |
| GND                     |                        | Y or N                                                    | Ground. If line is ground start, enter Y. Enter N for loop start.                                                                                                                                                                                                                                                                                                                                                                                                                                                                                                                                                                            |
| BNV                     |                        | L or NL                                                   | Balanced network value. Enter L when the line circuit configures for a loaded network. Enter NL for nonloaded network.                                                                                                                                                                                                                                                                                                                                                                                                                                                                                                                       |
| MNO                     |                        | Y or N                                                    | Manual override. Enter Y to prevent an on-hook balance network test from updating field BNV in this table. Enter N to allow an off-hook balance network test to update field BNV in this table.                                                                                                                                                                                                                                                                                                                                                                                                                                              |

## Basic Call Processing (continued)

### Datafilling table LNINV (Sheet 4 of 4)

| Field    | Subfield or refinement | Entry                                              | Explanation and action                                   |
|----------|------------------------|----------------------------------------------------|----------------------------------------------------------|
| CARDINFO |                        | refer to subfield                                  | Card information. This field contains subfield CARDTYPE. |
|          | CARDTYPE               | ISLCC,<br>SSLCC,<br>REUEPOTS,<br>RCUPOTS or<br>NIL | Card type. The NIL is the default.                       |

### Datafill example for table LNINV

Sample datafill for table LNINV appears in the following table.

### MAP example for table LNINV

| Table: LNINV |            |          |        |         |     |     |     |          |  |  |  |
|--------------|------------|----------|--------|---------|-----|-----|-----|----------|--|--|--|
|              | LEN        | CARDCODE | PADGRP | STATUS  | GND | BNV | MNO | CARDINFO |  |  |  |
| HOST         | 00 0 00 01 | 6X17AA   | STDLN  | WORKING | N   | NL  | N   | NIL      |  |  |  |
| HOST         | 00 0 00 04 | 6X17AB   | STDLN  | WORKING | N   | NL  | N   | NIL      |  |  |  |
| HOST         | 00 0 00 05 | 6X17AB   | STDLN  | WORKING | N   | NL  | N   | NIL      |  |  |  |

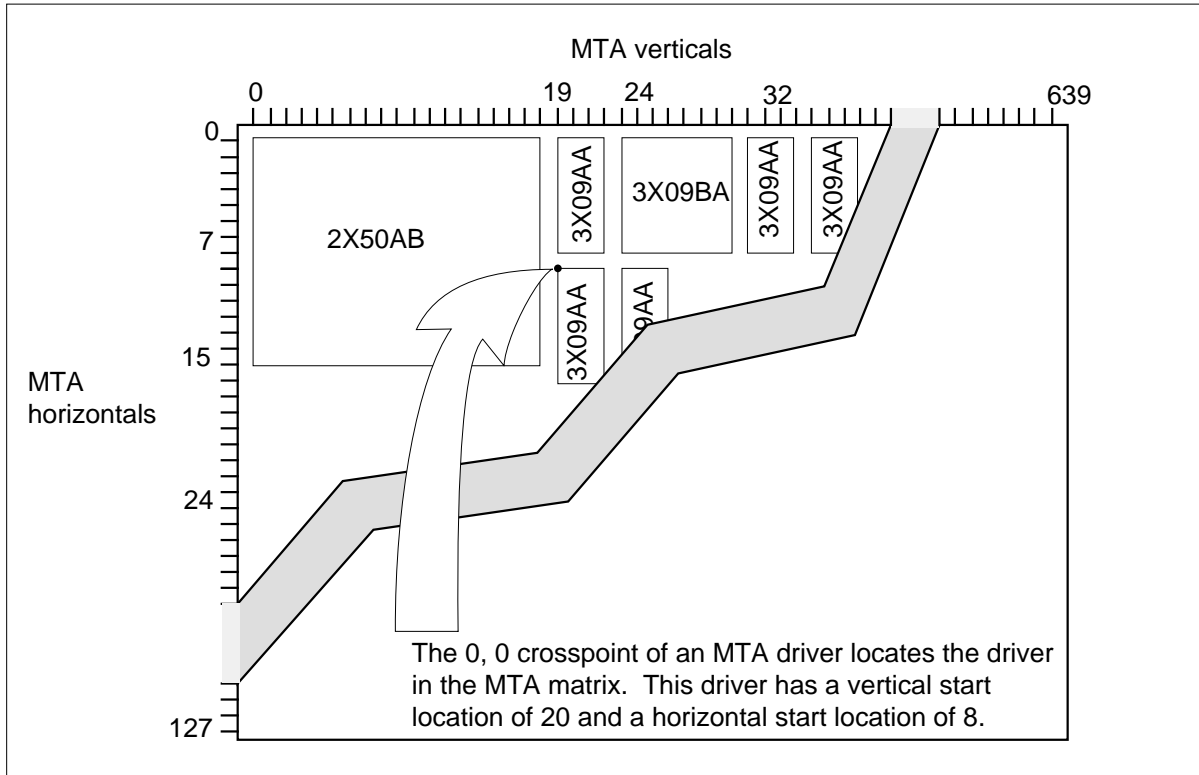
### Datafilling table MTAMDRVE

The metallic test access (MTA) network is a matrix of vertical and horizontal crosspoints, like a minibar. This network connects specified verticals to horizontal in the network. The MTA connects test equipment to a circuit that requires testing. The MTA connects a horizontal to a vertical.

An MTA network of the required size is a number of small, interconnecting minibar circuits used as building block parts. Refer to the MTA Matrix below. The NT3X09AA Remote Metallic Test Access driver allows MTA to remote line concentrating devices, including the RCS. The NT3X09AA is a four vertical by eight horizontal circuit. The NT3X09BA 8x8 metallic test access is an eight vertical by eight horizontal circuit.

## Basic Call Processing (continued)

### MTA matrix



The MTA minibar driver table MTAMDRVE specifies the location and type of minibar driver assigned to the minibar switch. The NT2X50AB Minibar driver is part of the NT2X46 Minibar Switch Assembly. The NT3X09AA driver has relays on the card and does not require an associated minibar switch. The 0, 0 crosspoint in the matrix identifies each minibar driver.

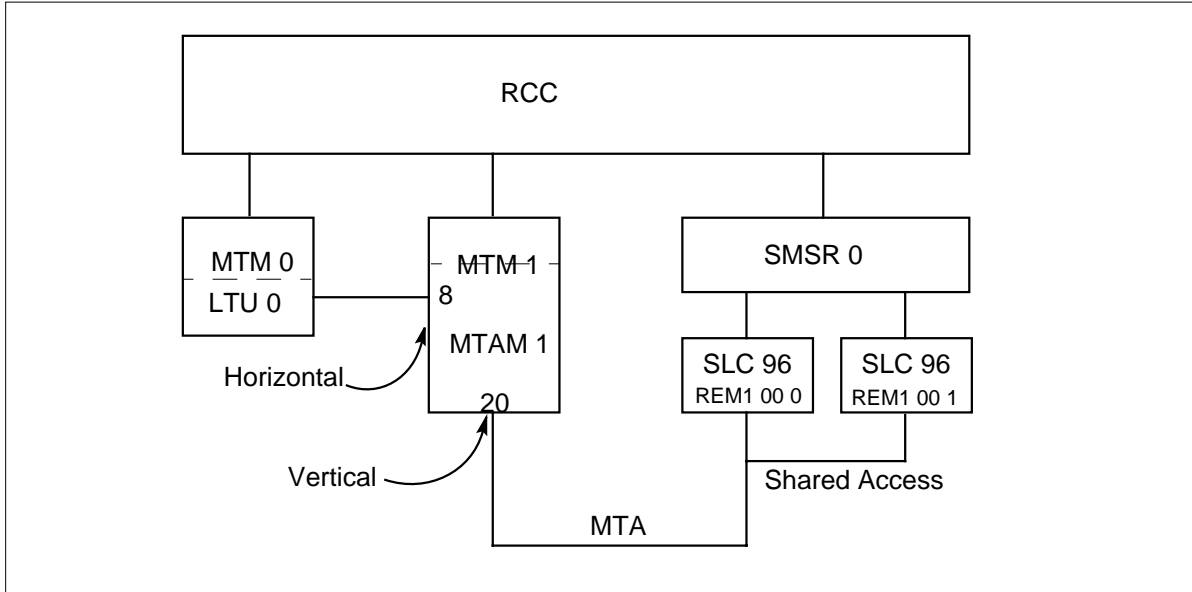
### MTAMDRVE datafill procedure

The datafill for table MTAMDRVE appears in the following procedure. This procedure contains the fields that apply to basic call processing. Refer to the data schema section of this document for a description of the other fields.

The examples that appear in the procedure correspond to the example MTA configuration that appears in the figure below. The examples in the procedure correspond to examples of tuples that appear at the end of this procedure.

## Basic Call Processing (continued)

### Example MTA configuration



The datafill for Basic Call Processing for table MTAMDRVE appears in the following table. The fields that apply to Basic Call Processing appear. Refer to the data schema section of this document for a description of the other fields.

### Datafilling table MTAMDRVE (Sheet 1 of 2)

| Field  | Subfield or refinement | Entry         | Explanation and action                                                                                              |
|--------|------------------------|---------------|---------------------------------------------------------------------------------------------------------------------|
| MTAMEM |                        | 0 to 511      | Metallic test access minibar driver member. Enter the MTA driver member number. This field is the key to the table. |
| VERT   |                        | 0 to 1023     | MTAM driver vertical start location. Enter the vertical start location for the MTAM driver.                         |
| HORIZ  |                        | 0 to 127      | MTAM driver horizontal start location. Enter the horizontal start location for the MTAM driver.                     |
| TMTYPE |                        | MTM, RSM, RMM | Trunk module type. Enter the type of trunk module that contains the minibar driver.                                 |
| TMNO   |                        | 0 to 2047     | Trunk module number. Enter the number assigned to the maintenance trunk module.                                     |

**Basic Call Processing** (continued)**Datafilling table MTAMDRVE (Sheet 2 of 2)**

| Field   | Subfield or refinement | Entry                        | Explanation and action                                                                                 |
|---------|------------------------|------------------------------|--------------------------------------------------------------------------------------------------------|
| TMCKTNO |                        | 0 to 28 (even numbers only)  | Trunk module circuit number. Enter the circuit number of the MTM where the minibar driver is assigned. |
| MTACARD |                        | 2X50AB,<br>3X09AA,<br>3X09BA | MTAM driver card. Enter the card code for the metallic test access minibar driver card.                |

**Datafill example for table MTAMDRVE**

Sample datafill for table MTAMDRVE appears in the following example.

**MAP example for table MTAMDRVE**

| Table: MTAMDRVE |      |       |        |      |         |         |
|-----------------|------|-------|--------|------|---------|---------|
| MTAMEM          | VERT | HORIZ | TMTYPE | TMNO | TMCKTNO | MTACARD |
| 1               | 20   | 8     | MTM    | 1    | 10      | 3X09AA  |

**Datafilling table MTAVERT**

The metallic test access vertical connection table (MTAVERT) identifies the vertical connectivity to the MTA matrix. The two types of connections allowed are single and multiple. The SMS-R/RCS system uses the multiple connection because a maximum of 32 RCS modules can share a metallic test pair.

The datafill for Basic Call Processing for table MTAVERT appear in the following table. The fields that apply to Basic Call Processing appear. Refer to the data schema section of this document for a description of the other fields.

The command string examples appear in the procedure correspond to examples of tuples that appear at the end of this procedure. The command

## Basic Call Processing (continued)

string examples correspond to the example MTA configuration that appears in the figure under MTAMDRVE.

### Datafilling table MTAVERT

| Field    | Subfield or refinement | Entry                                     | Explanation and action                                                                                                                                                                       |
|----------|------------------------|-------------------------------------------|----------------------------------------------------------------------------------------------------------------------------------------------------------------------------------------------|
| VERT     |                        | 0 to 1023                                 | Vertical. Enter the MTA vertical connection number.                                                                                                                                          |
| VERTCONN |                        | refer to subfields                        | Vertical connection. Enter M to indicate multiple connections. A maximum of 32 RCS modules can share a metallic test pair.                                                                   |
|          | VERTSEL                | S or M                                    | Vertical connection type selector. Enter one of two types of vertical connections. If you select S, subfield VERTITEM requires entries. If you select M, subfield VERTAREA requires entries. |
|          | VERTITEM               | refer to subfield                         | Vertical item. Enter data in subfield SELECTOR and refinements.                                                                                                                              |
|          | VERTAREA               | refer to subfield                         | Vertical area. Enter data in subfield SELECTOR and refinements.                                                                                                                              |
|          | SELECTOR               | L, E, O or T                              | Selector. Enter selector O if the entry in VERTCONN is M. Subfields SITE, FRAME, and UNIT are entered after the selector. This selector is a vector of a maximum of 32 entries.              |
|          | SITE                   | alphanumeric (1 to 4 characters or blank) | Site name. Enter the name selected for the remote location.                                                                                                                                  |
|          | FRAME                  | 0 to 511                                  | Frame number. Enter the frame number.                                                                                                                                                        |
|          | UNIT                   | 0 to 9                                    | Unit number. Enter the unit number.                                                                                                                                                          |

### Datafill example for table MTAVERT

Sample datafill for table MTAVERT appears in the following example.

---

**Basic Call Processing** (continued)
 

---

**MAP example for table MTAVERT**

| Table: MTAVERT |               |
|----------------|---------------|
| VERT           | VERTCONN      |
| 0              | S L HOST 00 0 |
| 2              | S L HOST 00 1 |

**Datafilling table MTAHORIZ**

The metallic test access horizontal connection table (MTAHORIZ) lists the assignment of horizontal agents to a horizontal and horizontal group of metallic test access minibars (MTAMs). Horizontal agents include the following:

- LTU
- metallic test units (MTU)
- operator verification
- metallic jacks (MJACK)
- incoming test access trunks
- extended metallic test access
- short circuits

Different horizontal agents can use the same horizontal if agents associate with different MTAMs or horizontal groups. A maximum of 160 different horizontal agents can occur for a given horizontal.

A maximum of 32 MTAMs (grouped) can multiply to connect to a single horizontal agent. A horizontal agent can be used one time.

The datafill for Basic Call Processing for table MTAHORIZ appears in the following table. The fields that apply to Basic Call Processing appear. Refer to the data schema section of this document for a description of the other fields.

The examples that appear this procedure correspond to examples of tuples that appear at the end of this procedure. The examples that appear in this procedure

**Basic Call Processing** (continued)

correspond to the example MTA configuration that appears in the figure under Datafilling MTAMDRVE.

**Datafilling table MTAHORIZ (Sheet 1 of 2)**

| Field    | Subfield or refinement | Entry                      | Explanation and action                                                                                                                                                                                                                                                                                                                                                                                                                                                                                                                                                                                                                                                                                                                                                                                  |
|----------|------------------------|----------------------------|---------------------------------------------------------------------------------------------------------------------------------------------------------------------------------------------------------------------------------------------------------------------------------------------------------------------------------------------------------------------------------------------------------------------------------------------------------------------------------------------------------------------------------------------------------------------------------------------------------------------------------------------------------------------------------------------------------------------------------------------------------------------------------------------------------|
| HORIZ    |                        | 0 to 127                   | MTA Horizontal. Enter the MTA horizontal where the test equipment (horizontal agent) connects.                                                                                                                                                                                                                                                                                                                                                                                                                                                                                                                                                                                                                                                                                                          |
| HORIZGRP |                        | 0 to 159                   | MTA Horizontal Group. Enter the horizontal group number that identifies the horizontal and the horizontal agent as a different tuple. The horizontal group allows the assignment of different test equipment on the same MTA horizontal.                                                                                                                                                                                                                                                                                                                                                                                                                                                                                                                                                                |
| HORIZAGT |                        | refer to subfield          | Horizontal agent. This field contains several subfields that depend on the value of SELECTOR used.                                                                                                                                                                                                                                                                                                                                                                                                                                                                                                                                                                                                                                                                                                      |
|          | SELECTOR               | S, L, T, B, NT1, MJ, J, LA | Selector. Enter S for a timed short circuit. Enter L for LTU or MTU assignment and complete subfields CLLI, EXTRKNM and ALTUSE. Refer to Notes 1, 2, 6 and 7 that follow. Enter T for incoming test access or operator verification trunk assignment and complete subfields CLLI and EXTRKNM. Refer to Notes 3, 4 and 5 that follow. Enter B for a board-to-board dedicated horizontal and complete subfield BBTNR. Enter E to multiply a horizontal of a minibar switch from a host or remote. Multiply the horizontal to the vertical of a host minibar switch. Complete subfield EMTAVERT. Refer to Notes 3, 4 and 5 that follow. Enter MJ for a metallic connection to the tip and ring of the subscriber line. Complete subfields CLLI and MJACKNUM. Selectors J and LA are for licensee use only. |
|          | CLLI                   | MTU or LTU                 | Common language location identifier. Enter LTU for a line test unit. Refer to Notes 1, 2, 6 and 7 that follow. Enter MTU for a metallic test unit. For operator verification or an incoming test access trunk, enter the alphanumeric code that represents this trunk group in table CLLI.                                                                                                                                                                                                                                                                                                                                                                                                                                                                                                              |



**Basic Call Processing** (continued)

Datafilling table MTAHORIZ (Sheet 2 of 2)

| Field  | Subfield or refinement | Entry     | Explanation and action                                                                                                                                                                                                                                                                          |
|--------|------------------------|-----------|-------------------------------------------------------------------------------------------------------------------------------------------------------------------------------------------------------------------------------------------------------------------------------------------------|
|        | EXTRKNM                | 0 to 9999 | External trunk number. Enter the external trunk number assigned in table TRKMEM to the following: <ul style="list-style-type: none"> <li>• the line test unit</li> <li>• the metallic test unit</li> <li>• the operator verification trunk</li> <li>• the incoming test access trunk</li> </ul> |
|        | ALTUSE                 | Y or N    | Automatic line test use. Enter Y to use line test equipment for automatic line testing (ALT). Enter N for other conditions.                                                                                                                                                                     |
|        | BBTNR                  | 0 to 7    | Board-to-board testing number. Enter the number of the board-to-board set where this horizontal is associated.                                                                                                                                                                                  |
|        | EMTAVERT               | 0 to 1023 | Extended metallic test access column. Enter the associated vertical on the MTA in the host where the horizontal connects.                                                                                                                                                                       |
|        | MJACKNUM               | 1 to 256  | Metallic jack number. If the entry in subfield CLLI is MJACK, enter the metallic jack number.<br><br><b>Note:</b> The number of metallic jacks in each DMS office cannot exceed 256.                                                                                                            |
| MTAGRP |                        | numeric   | MTA group. Contains a list of MTA drivers that multiply to the test equipment. This field is a vector of a maximum of 32 multiples of subfields MTAMEM and HORIZ.                                                                                                                               |
|        | MTAMEM                 | 0 to 511  | The MTA minibar driver member. Enter the MTAM driver member number where the horizontal connects.                                                                                                                                                                                               |
|        | HORIZ                  | 0         | Horizontal. This field is read only. This field provides information about the physical horizontal where the MTA drivers connect. Enter 0 to satisfy table control.                                                                                                                             |

**Note 1:** Horizontals are not reserved for dedicated LTUs. The LTUs that are not dedicated do not have limits on assignment.

## Basic Call Processing (continued)

---

**Note 2:** When an LTU is assigned to the host switching unit, the system multiplies the horizontal where the LTU is assigned. The system multiplies the LTU to all minibar switches assigned to the host switching unit. When an LTU is assigned to a remote location, the LTU is assigned to a horizontal. The system multiplies this horizontal to all minibar switches assigned to the remote location.

**Note 3:** When the minibar switch is at the host switching unit, there is no assignment limit for the assignment of incoming test and operator verification trunks. Each incoming test access trunk and operator verification trunk require one horizontal.

**Note 4:** When the MTA configuration is small or medium, the horizontals where the incoming test access and operator verification trunks are assigned and are multiplied to the minibar switches at the host switching unit.

**Note 5:** When the minibar switch is remote from the host switching unit, the horizontals are available for assignment of incoming test access trunks. The horizontals are also available for operator verification trunks and extension of metallic test access feature. One horizontal is necessary for each incoming test access trunk and operator verification trunk. One horizontal is also necessary for each vertical on the host minibar switch. The host minibar switch is assigned to a horizontal on the minibar switch at the remote or host location.

**Note 6:** Refer to tables TRKGRP, TRKSGRP and TRKMEM for assignments of LTUs, incoming test access and operator verification trunks to trunk groups. Refer to these tables for assignments of trunk subgroups and trunk member tables.

**Note 7:** An LTU or MTU is entered in table TRKMEM before the LTU or MTU is added to table MTAHORIZ. If the user deletes the LTU or MTU from table TRKMEM, the system marks the tuple as deleted. This tuple corresponds in table MTAHORIZ. The system restores this tuple if the LTU or MTU is added again in table TRKMEM.

**Note 8:** The memory for this table dynamically allocates to a maximum of 2 000 tuples.

### Datafill example for table MTAHORIZ

Sample datafill for table MTAHORIZ appears in the following table.

---

**Basic Call Processing** (continued)
 

---

**MAP display example for table MTAHORIZ**

|                 |   |   |          |   |   |         |           |
|-----------------|---|---|----------|---|---|---------|-----------|
| Table: MTAHORIZ |   |   |          |   |   |         |           |
| HORIZ           |   |   |          |   |   |         |           |
| HORIZGRP        |   |   | HORIZAGT |   |   | MTAGRP  |           |
| <hr/>           |   |   |          |   |   |         |           |
| 8               |   |   |          |   |   |         |           |
|                 | 0 | L | LTU      | 0 | Y | ( 0 0 ) | ( 2 0 )\$ |

**Tools for verifying translations****Central Office Data Engineering System (CODES)**

The Central Office Data Engineering System (CODES) is a fully automated system. This system helps translations data input for new and extension DMS-100 Family central offices. Many CODES abilities help operating company personnel with engineering translations data. These capabilities are described below.

**Data verification**

Full, data-checking features in CODES allow users to verify data accuracy as a job progresses and when the job is complete. Users submit completed jobs that are normally error-free. The following table describes CODES data-checking features.

**CODES data-checking features (Sheet 1 of 2)**

| Feature                                                                      | Description                                                                                                                                                                                                                        |
|------------------------------------------------------------------------------|------------------------------------------------------------------------------------------------------------------------------------------------------------------------------------------------------------------------------------|
| Intertable checking                                                          | Prevents the entrance of data that does not correctly match data in corresponding tables. The user can disable this feature to allow data to enter. This data changes when the table data that corresponds enters at a later time. |
| Data-integrity checking                                                      | Makes sure that input in a completed job correctly matches the data that corresponds in other tables.                                                                                                                              |
| <b>Note:</b> Complete call processing checking is not provided at this time. |                                                                                                                                                                                                                                    |

---

## Basic Call Processing (continued)

---

### CODES data-checking features (Sheet 2 of 2)

| Feature                                                                      | Description                                                                                                                                                  |
|------------------------------------------------------------------------------|--------------------------------------------------------------------------------------------------------------------------------------------------------------|
| Incomplete table identification                                              | Alerts the user to a missed field as the cursor moves from a tuple. The user can locate and enter data in missing fields throughout a completed job.         |
| Digit-range checking                                                         | Does not allow the user to enter invalid digit ranges or digit ranges that overlap in a table. The user can check for digit-range errors in a completed job. |
| <b>Note:</b> Complete call processing checking is not provided at this time. |                                                                                                                                                              |

### Tools for verifying translations

*Duplicating data.* Duplication of tuples and subtables creates new tables. The system incorporates these tuples and subtuples in the new table. Table-specific fields require entries.

*Data compilation.* The CODES provide commands that allow users to quickly find, select and sort tuples and fields. The customer data schema reference (CDSREF) command directs the user to a table with an explanation in an NT document.

*Translations maintenance/final lines feature.* The translations Maintenance/Final Lines (TM/FL) feature provides new capabilities for decentralized users of CODES.

*Translations maintenance.* The TM/FL feature allows the operating company to poll the DMS-100 Family switches. The TM/FL allows the operating company to upload the desired translations tables in a CODES database. The TM/FL feature allows downloading of translations data from CODES directly to a DMS-100 Family switch.

The ability to upload and download between a DMS-100 Family switch and CODES expedites and simplifies translations engineering as follows:

- tables common to many switches are uploaded to CODES and used as standardized data to engineer new switches. Tables uploaded from a current switch provide a base for data-integrity verification for an extension to the switch.
- uploaded tables verify that information from an in-service switch matches data for that switch in CODES.

---

## Basic Call Processing (continued)

---

- operating company personnel gather work orders in CODES and download the orders to a buffer area in a DMS-100 Family switch. Operating company personnel gather the work orders and download the orders for execution. This procedure replaces hardcopy or other slower methods of work-order administration.
- switch translations data uploads and merges with data for that switch in CODES. This capability provides an automated process to upgrade the office in CODES to the current BCS level. This ability normally eliminates manual upgrades of the CODES database.

*Final lines.* The operating company loads final lines data in a DMS-100 Family switch. To load the final lines data, the operating company uses the TM/FL feature with current CODES capabilities. After the conversion of the final lines data from the current format to CODES, the operating company can perform the following:

- correct errors early in the engineering process with use of data-checking procedures, available through CODES with TM/FL
- provide the most current data possible because final-lines changes are input later in the engineering process
- data check a whole office to prevent errors, like directory-number duplications between current data and new final lines data

*Implementing CODES.* Operating companies use flexible decentralized or centralized access formats as follows:

- decentralized users maintain CODES account on the PCs or minicomputers of the users. These users send final data input electronically or on disk for verification by a regional NT engineer.
- centralized users can access CODES account and submit final data input. The centralized users dial the NT Hewlett-Packard 9000 (HP 9000) CODES minicomputer with an 800 number or OUTWATS line.

At Nortel, data files from the user CODES account are combined with different equipment and engineering databases. These data files are combined with other data that verify the final translations output. The combined files are uploaded to the Northern Telecom laboratory switch. The combined files are used to develop and test the final translations output. This final output loads from a magnetic-tape drive to the DMS-100 Family switch of the operating company.

### CHECKTAB

The CHECKTAB is a table verification process that operating company uses before operating company personnel make an image tape. The CHECKTAB

## Basic Call Processing (continued)

---

can verify office datafill. If CHECKTAB is not available, the TABCHK utility can verify the tables.

*Note 1:* Before you run CHECKTAB, access all software delivery bulletins that apply to CHECKTAB through C-SCAN. Make sure to follow the bulletin instructions when you use CHECKTAB.

*Note 2:* To determine if CHECKTAB is available, enter HELP CHECKTAB at the MAP terminal. If CHECKTAB is available, a detailed help message appears. If CHECKTAB is not available, a response of NO COMMAND IN LINE appears.

The CHECKTAB runs on a separate table or on multiple tables that use the ALL option. If you use ALL, the system checks all tables that table CUSTAB lists. The system also identifies any data corruption or differences in the software tables. The output from CHECKTAB directs to the MAP screen, printer, disk, tape or store file. Output can direct to a user-specified device (SFDEV), tape or disk. The system stores results in a file called SUMMARY\$FILE.

The CHECKTAB reads and writes (without any data changes) every tuple in a table to perform a table check. If the read or write operation fails, the tuple position appears. This action allows identification of the table and the exact problem tuple. Normal table editor comments and warnings appears use of CHECKTAB detects errors.

The operating company corrects errors and inconsistent data that CHECKTAB identifies before the creation of the system image tape

### TABCHK

The TABCHK program is available at BCS levels. This program checks data, counts the tuples in a table, and checks for false tops and bottoms in a table.

If the current BCS is 28 or up, use CHECKTAB instead of TABCHK to provide a more extensive table check.

The output from TABCHK, when used to verify Basic Call Processing, appears in the following example.

### SERVORD

The service order system (SERVORD) provides operating companies with an effective means to perform the following options:

- add or remove subscriber service from lines
- add or delete line service options

---

**Basic Call Processing** (continued)

---

- change the LEN and DN of current lines
- add to or delete features from lines

A service order can enter in prompt mode or nonprompt mode. Prompt mode occurs when the system prompts the user for input. Nonprompt mode occurs when all input is entered in one command string. When entry of a service order is complete, the complete service order appears for verification purposes. The system prompts for a Y (yes), N (no) or E (edit). Enter N to abort the service order or E to edit the service order in prompt mode. If you enter Y, the system verifies the service order. If the system detects an error, the the system rejects the service order. The system accepts for immediate activation a service order entered without a service order number (SONUMBER).

You can use the SERVORD to add or delete line datafill in table LNINV for remote fiber terminal (RFT) lines. The RFT lines are in an S/DMS AccessNode system. This auto-create ability removes a manual step. This auto-create ability allows the system to provision software and services on the card in a single SERVORD transaction.

Line entries in table LNINV is not present before submission of a SERVORD provision request.

If line entries does not appear in table LNINV, SERVORD adds entries. These entries are based on user input, office parameter values and default values.

If line entries is present, SERVORD alters the data to conform to the service requested. A service removal request removes datafill for a line, including LNINV data.

The SERVORD user input determines the values for the following LNINV fields:

- LEN
- CARDCODE
- PADGRP
- GND
- CARDTYPE

The system draws the LNINV field BNV from a hard-coded default. The default is NL (non-loaded) if an addition of a tuple occurs. To change the value to L (loaded), edit the LNINV tuple.

---

**Basic Call Processing** (continued)
 

---

If entries are present for a line, and the SERVORD transaction alters that entry, the BNV value defaults to NL.

The system takes the LNINV field MNO from RDT\_SO\_AUTOCREATE\_LNINV, a new office parameter in table OFCENG. This parameter determines if the MNO default is Y (Yes) or N (No).

A line entries can be present for a line and the SERVORD transaction can alter that line. When this event occurs, the MNO value defaults to the value in parameter RDT\_SO\_AUTOCREATE\_LNINV.

The system enables or disables this auto-create capability through the parameter RDT\_SO\_AUTOCREATE\_LNINV. If the system disables the auto-create capability, line datafill in table LNINV must be present before the system can provide new service.

Enabling and disabling the auto-create capability affects the default values in fields BNV and MNO. Cross-references of current datafilled LNINV tuples, ability enabled or disabled, BNV value and MNO value appear in the following table.

**Cross-reference of current LNINV datafill, auto-create enabled or disabled, BNV value and MNO value**

| <b>Datafilled LNINV tuple is present?</b> | <b>Auto-create enabled?</b> | <b>BNV value after transaction</b>             | <b>MNO value after transaction</b>             |
|-------------------------------------------|-----------------------------|------------------------------------------------|------------------------------------------------|
| Y                                         | enabled                     | NL                                             | office parameter                               |
| N                                         | enabled                     | NL                                             | office parameter                               |
| Y                                         | disabled                    | copied from current tuple                      | copied from current tuple                      |
| N                                         | disabled                    | transaction failed and error message generated | transaction failed and error message generated |



---

## Basic Call Processing (continued)

---

### SERVORD commands

The table below lists and describes service order commands.

#### SERVORD commands

| Command | Description                                                                           |
|---------|---------------------------------------------------------------------------------------|
| SERVORD | Accesses service order software.                                                      |
| ADD     | Adds a line(s) to a current hunt group. Adds current lines to a call pickup group.    |
| ADO     | Adds options to lines. Adds current lines to a directory number hunt (DNH) group.     |
| DEL     | Deletes a line(s) from a hunt group (applies to all hunt group members except pilot). |
| DEO     | Deletes options from lines.                                                           |
| NEW     | Establishes a new service (applies to each nonhunt line and party line).              |
| OUT     | Removes a service (applies to each line and the pilot of hunt group).                 |

### SERVORD limits

The following limits apply to the auto-create capability:

- this capability only affects table LNINV datafill for RFT lines in S/DMS AccessNode systems
- this capability improves flow-through provisioning for locally switched services provided on RFT service adaptive access (SAA) line cards. This capability does not affect service provisioning for non-locally switched services, non-switched services or special services.
- the SERVORD provides this capability. The table editor interface does not provide this capability.
- the RFT must maintain DMS messaging. The SERVORD transaction succeeds if DMS messaging to the RFT cuts off. The SERVORD transaction succeeds if a problem occurs at the RFT that does not allow the RFT to fulfill a request. The line is system-busied and a the system generates log.

## Basic Call Processing (continued)

- the line must maintain service. The SERVORD transaction succeeds if table LNINV receives datafill and the line cannot return to service (RTS). The line is system-busied and a the system generates a log.
- input must meet with the current service. If the user attempts to submit a request that is not compatible, the SERVORD transaction fails. An option that is not compatible with the service is an example of an request that is not compatible.

### SERVORD prompts

The service order prompts that implement separate line option appear in the following table. The line options appear in the example service orders.

#### SERVORD prompts for Basic Call Processing (Sheet 1 of 2)

| Prompt   | Valid input                                     | Explanation                                                                                                                                                                                                                                                                                                                                                                |
|----------|-------------------------------------------------|----------------------------------------------------------------------------------------------------------------------------------------------------------------------------------------------------------------------------------------------------------------------------------------------------------------------------------------------------------------------------|
| DN       | Seven digits, entered with no spaces or hyphens | Directory number (DN) that associates with a service to establish, modify or delete.                                                                                                                                                                                                                                                                                       |
| LCC      | 1FR                                             | Line class code of a service to establish, modify or delete. The 1FR is the seperate flat rate for residence and business.                                                                                                                                                                                                                                                 |
| LATANAME | NILLATA (LATA name defined in table LATANAME)   | The calling LATA name that associates with the originator of the call.                                                                                                                                                                                                                                                                                                     |
| LTG      | 0 to 63                                         | Line treatment group number. Calculates a line attribute index when the DN and LCC are not enough to find the correct index.                                                                                                                                                                                                                                               |
| LEN      | <site> ffuddcc                                  | Line equipment number (LEN) that associates with a service to establish, modify or delete, as follows: <ul style="list-style-type: none"> <li>• site is the site name (defaults to host)</li> <li>• ff is the frame number</li> <li>• u is the unit number</li> <li>• dd is the drawer number of the line spread group</li> <li>• cc is the line circuit number</li> </ul> |

---

## Basic Call Processing (continued)

---

### SERVORD prompts for Basic Call Processing (Sheet 2 of 2)

| Prompt             | Valid input                     | Explanation                  |
|--------------------|---------------------------------|------------------------------|
| OPTION             | Digitone                        | Line service options.        |
| INTERCEPT_<br>NAME | Four alphanumeric<br>characters | Type of intercept necessary. |

### SERVORD example for adding a line to table LNINV

The following SERVORD example shows how table LNINV receives 1FR service by use of the NEW command. The example shows how an S/DMS AccessNode line can receive 1FR service. A tuple is not present before the transaction.

### SERVORD example for adding a line to table LNINV

```

>NEW
SONUMBER: NOW 93 11 10AM
>
DN:
> 6216001
LCC:
> 1fr
LATANAME:
> nillata
LEN_OR_LTID:
> rdt1 6 0 1 1
OPTION:
> gnd
OPTION:
> $
COMMAND AS ENTERED; NEW NOW 93 11 10AM 6216001 1FR
NILLATA RDT1 06 0 01 01 (GND) $
ENTER Y TO CONFIRM,N TO REJECT OR E TO EDIT y
LEN: RDT1 06 0 01 01 RDT line provisioning request completed

```

### SERVORD example for deleting a line from table LNINV

The following SERVORD example shows how a line deletes from table LNINV with the OUT command.

## Basic Call Processing (continued)

---

### SERVORD example for deleting a line from table LNINV

```
>OUT
SONUMBER: NOW 93 11 10AM
>
DN:
> 6216001
LEN:
> rdt1 6 0 1 1
INTERCEPT NAME:
> bldn
COMMAND AS ENTERED: OUT NOW 93 11 10AM 6216001 RDT1 06 0
01 01 BLDN
ENTER Y TO CONFIRM,N TO REJECT OR E TO EDIT y
LEN: RDT1 06 0 01 01 RDT line provisioning request
completed
```

### SERVORD example for changing a line in table LNINV

The following SERVORD example shows how a line changes in table LNINV with the CLN command. In the example, POTS service transfers from RDT1 6 0 1 1 to RDT1 6 0 1 2 and datafill is not current for RDT 1 6 0 1 2.

### SERVORD example for changing a line in table LNINV

```
>NEW
SONUMBER: NOW 93 11 10AM
>
DN:
> 6216001
LCC:
> 1fr
LATANAME:
> nillata
LEN_OR_LLTID:
> rdt1 6 0 1 1
OPTION:
> gnd
OPTION:
> $
COMMAND AS ENTERED: NEW NOW 93 11 10AM 6216001 1FR
NILLATA RDT1 06 0 01 01 (GND) $
ENTER Y TO CONFIRM,N TO REJECT OR E TO EDIT y
LEN: RDT1 06 0 01 01 RDT line provisioning request completed
```

---

## Basic Call Processing (end)

---

### SERVORD example for adding an option to an individual line

```

>SERVORD
SO:
>ADO
SONUMBER:
><RETURN>
DN_OR_LEN:
> 5320105
OPTION:
>DGT
OPTION:
>$
COMMAND AS ENTERED
ADO NOW 90 11 13 PM HOST 00 0 01 27 (DGT) $
ENTER Y TO CONFIRM,N TO REJECT OR E TO EDIT
>Y

```

### SERVORD example for deleting an option from an individual line

```

>SERVORD
SO:
>DEO
SONUMBER:
><RETURN>
DN_OR_LEN:
> 00 0 01 27
OPTION:
>DGT
OPTION:
>$
COMMAND AS ENTERED
DEO NOW 90 11 13 PM HOST 00 0 01 27 (DGT) $
ENTER Y TO CONFIRM,N TO REJECT OR E TO EDIT
>Y

```

### How SERVORD affects tables LENLINES, LINEATTR, and LENFEAT

If the user enters a line in table LNINV, SERVORD enters the line attribute number for the line in tables LINEATTR and LENLINES. The SERVORD enters the correct line options and feature information. This event occurs after the option or feature, or both, are entered with use of SERVORD.

## Special Services

---

### Functional group

BAS00016

### Feature package

NTXA86AA Special Services for Subscriber Carrier Module Remote

### Release applicability

BCS34 and later versions

### Requirements

Special Services requires the following feature packages, to operate:

- NTX000A Bilge
- NTX001AA Common Basic
- NTX270AA New Peripheral Maintenance Package
- NTX299AB Special Services for Subscriber Carrier Module-100S
- NTX398AA Subscriber Carrier Module-100S: Interface to SLC-96 Remote Terminal
- NTX901AA Local Features I
- NTXA85AA or NTXA85AB Subscriber Carrier Module SLC-96/Remote

### Description

Feature package NTXA86AA supports special service cards (channel units) in the RCS. This feature provides special services support for TR-008 digital line controllers (DLC). The SMS-R integrates these DLCs into the Remote Switching Center. This ability allows the operating company to use the SMS-R to offer services that generate revenue. These services include INWATS, OUTWATS, teletypewriter exchange (TWX), and PBX connectivity.

### Operation

Feature package NTXA86AA supports applications that require special service cards. To support these applications, software sets up and maintains a nailed-up cross-connection, also called a hairpin connection. This connection is a peripheral-side (P-side) cross-connection. The information flows from an RCS to the SMS-R. The system switches the information from the SMS-R to a DS-1 line. This DS-1 line leads to a second RCS or another piece of digital equipment. The system does not switch this information through the network.

---

## Special Services (continued)

---

The SMS-R provides the P-side hairpin ability. This ability allows the grooming of DS-0 channels from DS-1 links. These DS-1 links originate from remote terminals that the SMS-R serves. After the grooming, these channels combine on DS-1 link(s) that the system routes to channel bank(s). For the P-side, application of nailed-up P-side-to-P-side channel management occurs for special services. Connection information from the central controller determines if the SMS-R adds, removes, or audits these connections.

*Note 1:* Digital equipment other than an RCS can be the terminals of a cross-connection.

*Note 2:* An NT6X85AB DS-1 Interface card is used for peripheral-side cross-connections.

### Translations table flow

Special Services does not change standard translations data flow.

### Limits

The following limits apply to Special Services:

- For the channels on a DS-1 link to be part of a nailed-up connection, the following condition applies. The DS-1 must not be a remote link that serves a DMS-100 remote peripheral. Removal of nailed-up connections must occur before a remote peripheral attaches to the DS-1.
- In Mode II, special services circuit channel units are used in the four channel unit slots on the right on each shelf of the RCS.

### Interactions

Special Services does not have actions between functions.

### Activation/deactivation by the end user

Special Services does not require activation or deactivation by the end user.

### Billing

Special Services does not affect billing.

### Station Message Detail Recording

Special Services does not affect Station Message Detail Recording.

### Datafilling office parameters

Special Services does not affect office parameters.

## Special Services (continued)

---

### Datafill sequence

The following table lists the tables that require datafill to implement Special Services. The tables appear in the order in which the user enters data.

#### Datafill tables required for Special Services

| Table    | Purpose of table                                                                                                                                                                                                           |
|----------|----------------------------------------------------------------------------------------------------------------------------------------------------------------------------------------------------------------------------|
| LNINV    | Line Circuit Inventory. Retains an inventory of subscriber lines and associated line cards for RCS modules.                                                                                                                |
| PSNAILUP | P-Side Nailup. Retains an inventory of P-side to P-side nailed-up cross-connections. These connections have endpoints that are lines on an RCS or channels on a DS-1 line. This DS-1 line must connect to other equipment. |

### Datafilling table LNINV

The datafill for Special Services for table LNINV appears in the following table. Fields that apply directly to Special Services appear. For a description of the other fields, refer to the data schema section of this document.

The LNINV table holds an inventory of subscriber lines and associated line cards for RCS modules.

To accommodate RCS lines, data entry for table LNINV occurs. Fields do not change for RCS lines, except CARDCODE. The following card codes increase the range of values for this field:

- SCD271 (for SPOTS card used as single-party POTS card)
- NAILUP (for special service lines).

**Note 1:** Data entry for lines with special service card code NAILUP does not occur in table LENLINES.

**Note 2:** Data entry for endpoints used on an RCS occurs in table LNINV. Endpoints used on digital equipment, other than the RCS, must have the SMS-R data entered in table LTCRINV. These endpoints must have the DS-1 link data entered in table LTCRPINV.

### LEN format and physical and logical mapping of line circuits

For a description of the LEN format and physical and logical mapping of line circuits, refer to "Datafilling table PSNAILUP".



**Special Services** (continued)

Datafill for table LNINV appears in the following procedure. This procedure contains fields that apply to the Special Services feature. For a description of the other fields, refer to the data schema section of this document.

**Datafilling table LNINV**

| Field                                                                                                                                                                                                                                                                                                                                    | Subfield or refinement | Entry                                                                               | Description                                                                                                                         |
|------------------------------------------------------------------------------------------------------------------------------------------------------------------------------------------------------------------------------------------------------------------------------------------------------------------------------------------|------------------------|-------------------------------------------------------------------------------------|-------------------------------------------------------------------------------------------------------------------------------------|
| CARDCODE                                                                                                                                                                                                                                                                                                                                 |                        | Range<br>includes:<br>SCD203,<br>SCD221,<br>SCD233,<br>SCD271,<br>SCDFSR,<br>NAILUP | Card Code. Enter the PEC of the line card.<br>Range includes: SCD203, SCD221, SCD233,<br>SCD271, SCDFSR, NAILUP<br>Example: >NAILUP |
| <b>Note 1:</b> For addition as endpoints, configuration of special service lines must occur in table LNINV.                                                                                                                                                                                                                              |                        |                                                                                     |                                                                                                                                     |
| <b>Note 2:</b> Special service lines use even-numbered circuits in table LNINV.                                                                                                                                                                                                                                                          |                        |                                                                                     |                                                                                                                                     |
| <b>Note 3:</b> Before deletion of a special service line from this table occurs, deletion of the associated nailed-up cross-connection from table PSNAILUP must occur.                                                                                                                                                                   |                        |                                                                                     |                                                                                                                                     |
| <b>Note 4:</b> The SPOTS card is used for single-party or special services. When the card is used for special services, data entry for the card occurs as NAILUP. Data entry for the two circuits in the SPOTS card occurs as loop start or ground start. Data entry for the GND field Y for the two circuits or N for the two circuits. |                        |                                                                                     |                                                                                                                                     |
| <b>Note 5:</b> Data entry for the SPOTS cards must not occur in a mode III RCS. This condition applies because equipment in mode III multiplexes 48 time slots to two DS-1 lines. The equipment expects only single-circuit cards. If data entry for SPOTS cards occurs, even-numbered circuits for the cards are used.                  |                        |                                                                                     |                                                                                                                                     |

**Datafill example for table LNINV**

Sample datafill for table LNINV appear in the following example.

**MAP example for table LNINV**

```

 LEN CARDCODE PADGRP STATUS GND BNV MNO CARDINFO
REM1 00 0 00 16 NAILUP STDLN HASU N NL N NIL
REM1 00 1 02 16 NAILUP STDLN HASU N NL N NIL
REM1 00 1 03 16 NAILUP STDLN WORKING N NL N NIL

```

## Special Services (continued)

---

### Datafilling table PSNAILUP

Table PSNAILUP contains an inventory of P-side to P-side nailed-up cross-connections. The connections have endpoints that are lines on an RCS or channels on a DS-1 line. The DS-1 line connects to other digital equipment.

**Note 1:** Table PSNAILUP requires 14 bytes of memory in protected data store for each nailed-up cross-connection. Allocation of the size of table PSNAILUP occurs at restart time. Specification of the number of connections occurs in table DATASIZE. For additional information on table DATASIZE, refer to the data schema section of the *Translations Guide*.

**Note 2:** The two endpoints must be on the same SMS-R. If this condition does not occur, the following error message appears at the MAP terminal.

ENDPOINTS NOT CONFIGURED ON THE SAME SMSR

SMS-R NOT DATAFILLED IN LTCRINV (for lines)

**Note 3:** Data entry for the SMS-R must occur in table LTCRINV. If this condition does not occur, one of the following error messages appears at the MAP terminal.

*or*

DS1 NOT PROPERLY CONFIGURED (for DS-1 channels)

**Note 4:** The endpoints cannot be part of a current nailed-up cross-connection. If this condition does not occur, the following error message appears at the MAP terminal.

ENDPOINT PART OF AN EXISTING NAILED-UP CONNECTION

**Note 5:** Data entry for line endpoints must occur in table LNINV. If this condition does not occur, the following error message appears at the MAP terminal.

LINE NOT EQUIPPED

**Note 6:** Line endpoints must have card code NAILUP in table LNINV. If this condition does not occur, the following error message appears at the MAP terminal.

LINE NOT A SPECIAL SERVICES CIRCUIT

**Note 7:** The DS-1 channels must be on DS-1 lines entered in table LTCRPINV. If this condition does not occur, the following error message appears at the MAP terminal.

DS0 NOT ON AN EQUIPPED DS1

**Note 8:** The DS-1 lines must have correct configuration in table LTCRPINV. If this condition does not occur, the following error message appears at the MAP terminal.

---

**Special Services** (continued)

---

**DS1 NOT PROPERLY CONFIGURED**

**Note 9:** The DS-1 channels cannot be on DS-1 lines that terminate on an RCS. If the channels are on these lines, the following error message appears at the MAP terminal.

**DS0 TERMINATES ON A REMOTE PERIPHERAL**

**Note 10:** The status of the nailed-up cross-connection must be A (active) or P (pending). If this condition does not occur, the following error message appears at the MAP terminal.

**MUST SPECIFY ACTIVE OR PENDING STATUS ONLY**

**Note 11:** You cannot change the ABINSERT field when the status of a nailed-up cross-connection is active or inactive. To change the ABINSERT field, you must change the status of the nailed-up cross connection to pending. If this condition does not occur, the following error message appears at the MAP terminal.

**CANNOT CHANGE ABINSERT FIELD WHEN STATUS IS ACTIVE OR INACTIVE**

**Note 12:** The system does not allow the table editor CHANGE command when an endpoint in table PSNAILUP must change. To change an endpoint, deletion of the tuple that contains the endpoint, and addition of a new tuple must occur. An attempt to change an endpoint with the CHANGE command results in the following error message.

**CHANGE COMMAND NOT ALLOWED ON ENDPOINTS**

Use the CHANGE command on the STATUS field of nailed-up cross connections.

**Note 13:** A component (SMS-R, RCS, or DS-1 link) used in a nailed-up cross-connection can be out of service. In this condition, the status of the connection is set to inactive, and the following message appears at the MAP:

**CONNECTION INACTIVE -- ENDPOINTS NOT IN SERVICE**

The connection becomes active when the DS-1 line returns to service.

**Note 14:** If DS-1 channels are part of a nailed-up cross-connection, an RCS cannot attach to the DS-1 link that holds these channels. Data entry cannot occur in table LENLINES for lines with special services card code NAILUP.

The datafill for table PSNAILUP appears in the following procedure. This procedure contains fields that apply to Special Services feature. For a description of the other fields, refer to the data schema section of this document.

**Note 15:** Data entry for endpoints used on a RCS occurs in table LNINV. Endpoints used on digital equipment other than the RCS have the SMS-R

**Special Services** (continued)

entered in table LTCRINV. These endpoints have the DS-1 link entered in table LTCRPINV.

**Datafilling table PSNAILUP (Sheet 1 of 2)**

| Field              | Subfield or refinement | Entry              | Description                                                                                                                                                                                                                                     |
|--------------------|------------------------|--------------------|-------------------------------------------------------------------------------------------------------------------------------------------------------------------------------------------------------------------------------------------------|
| ENDPT1             |                        | refer to subfields | Endpoint. Enter the first endpoint of the nailed-up cross connection. Consists of subfields PSSEL, PMNO, PORT, and CHNL; or subfields PSSEL and LEN.                                                                                            |
|                    | PSSEL                  | SMS-R or RCS       | P-side Selector. Enter SMS-R if the first endpoint is a DS-1 channel. Enter RCS if the first endpoint is an RCS line. If PSSEL is SMS-R, ENDPOINT1 includes PMNO, PORT, and CHNL. If PSSEL is RCS, ENDPOINT1 includes LEN.<br><br>Example: >RCS |
| ENDPT1 (continued) | PMNO                   | 0 to 127           | The PM Number. Enter the external number of the SMS-R peripheral. Range: 0 through 127                                                                                                                                                          |
|                    | PORT                   | 0 to 19            | The SMS-R P-side Port. Enter the P-side port number of the SMS-R. Range: 0 through 19                                                                                                                                                           |
|                    | CHNL                   | 1 to 24            | The P-side Circuit Time Slot. Enter the DS-1 channel (time slot). Range: 1 through 24                                                                                                                                                           |
|                    | LEN                    | alphanumeric       | Line Equipment Number. Enter the LEN of the RCS line. The LEN contains information about the site (four characters), frame (0 through 99), unit (0 through 9), line subgroup (0 through 3), and circuit (0 through 23)                          |
| ENDPT2             |                        | refer to subfields | Endpoint2. Enter the second endpoint of the nailed-up cross connection. This field consists of subfields PSSEL, PMNO, PORT, and CHNL; or subfields PSSEL and LEN.                                                                               |
|                    | PSSEL                  | SMS-R or RCS       | P-side Selector. Enter SMS-R if the second endpoint is a DS-1 channel. Enter RCS if the second endpoint is an RCS line. If PSSEL is SMS-R, ENDPOINT2 includes PMNO, PORT, and CHNL. If PSSEL is RCS, ENDPOINT2 includes LEN.                    |
|                    | PMNO                   | 0 to 127           | PM Number. Enter the external number of the SMS-R peripheral. Range: 0 through 127                                                                                                                                                              |

**Special Services** (continued)

Datafilling table PSNAILUP (Sheet 2 of 2)

| Field    | Subfield or refinement | Entry        | Description                                                                                                                                                                                                                                                                                                                                                                                                                                                                                                                                                                                                                                               |
|----------|------------------------|--------------|-----------------------------------------------------------------------------------------------------------------------------------------------------------------------------------------------------------------------------------------------------------------------------------------------------------------------------------------------------------------------------------------------------------------------------------------------------------------------------------------------------------------------------------------------------------------------------------------------------------------------------------------------------------|
|          | PORT                   | 0 to 19      | SMS-R P-side Port. Enter the P-side port number of the SMS-R. Range: 0 through 19                                                                                                                                                                                                                                                                                                                                                                                                                                                                                                                                                                         |
|          | CHNL                   | 1 to 24      | P-side Circuit Time Slot. Enter the DS-1 channel (time slot). Range: 1 through 24 (See Note)                                                                                                                                                                                                                                                                                                                                                                                                                                                                                                                                                              |
|          | LEN                    | alphanumeric | Line Equipment Number. Enter the LEN of the RCS line. The LEN contains information about the site (four characters), frame (0 through 99), unit (0 through 9), line subgroup (0 through 3), and circuit (0 through 23)                                                                                                                                                                                                                                                                                                                                                                                                                                    |
| STATUS   |                        | A, or P      | <p>Status. Enter the status of the connection as follows:</p> <p>Active (A) - data entry and set up of the connection occurs</p> <p>Pending (P) - data entry of the connection occurs, but the system does not set up the connection in the peripheral</p> <p>Inactive (I) - entry for the connection occurs, but the DS-1 link is not in service</p> <p><b>Note:</b> The switch operator cannot enter I. The system sets the status to inactive if the system cannot set up a connection after the connection entry occurs. The endpoints remain in table PSNAILUP. The system makes the connection active when the two endpoints return to service.</p> |
| ABINSERT |                        | Y or N       | A/B Bit Insertion. Enter N if A- and B-bits are not inserted. Data entry for data cards that use a DDS hairpin connection includes N. Data entry for voice connections that use A- and B-bits includes Y. The default is Y.                                                                                                                                                                                                                                                                                                                                                                                                                               |

**Datafill example for table PSNAILUP**

Sample datafill for table PSNAILUP appears in the following example.

## Special Services (end)

---

### MAP example for table PSNAILUP

| TABLE: PSNAILUP |      |   |   |   |   |        |      |   |   |   |   |        |   |          |  |
|-----------------|------|---|---|---|---|--------|------|---|---|---|---|--------|---|----------|--|
| ENDPT1          |      |   |   |   |   | ENDPT2 |      |   |   |   |   | STATUS |   | ABINSERT |  |
| RCS             | REM1 | 0 | 0 | 1 | 1 | RCS    | REM1 | 0 | 0 | 1 | 2 | P      |   | Y        |  |
| RCS             | REM1 | 0 | 0 | 1 | 3 | SMSR   |      | 0 | 2 | 1 | A |        | Y |          |  |
| SMSR            |      | 0 |   | 2 | 2 | RCS    | REM1 | 0 | 0 | 1 | 4 | A      |   | N        |  |
| SMSR            |      | 0 |   | 2 | 3 | SMSR   |      | 0 | 2 | 4 | I |        | N |          |  |

### Tools for verifying translations

Special Services does not use tools to verify translations.

### SERVORD

Special Services does not use SERVORD.

---

## Custom Local Area Signaling Services

---

### Functional group

RES00001

### Feature package

NTXE38AB Display Services—SCM/SMS

### Release applicability

BCS35 and higher

### Requirements

To operate, Custom Local Area Signaling Services (CLASS) requires the following feature packages:

- NTX401AA CLASS: Calling Number Display
- NTXA40AA Directory Number Attributes Package
- NTXA64AA (RES) Residential Enhanced Services Base
- NTXA82AA CLASS Line Office Data
- NTX000AA Bilge
- NTX001AA Common Basic
- NTX100AA Integrated Business Networks—Basic (IBN)
- NTX270AA New Peripheral Maintenance Package
- NTX398AA Subscriber Carrier Module-100S: Interface to SLC-96 Remote Terminal
- NTX413AA or NTX413AB IBN-Enhanced Call Forwarding
- NTXE56AA Selective List Editing
- NTXP91AA Downloadable Softkeys
- NTXP96AA Call Logging
- NTXQ91AA DSCWID
- NTX898AA Variable Speed Call Access Code—IBN
- NTX901AA Local Features I

### Description

These features allow the delivery of CLASS to customer premises equipment (CPE) that complies with Bellcore TR-30, TR-575, and TR-1273. The CLASS features are available for residential and small business subscriber lines that connect to an RCS. The SMS-R must serve these lines. The

## Custom Local Area Signaling Services (continued)

---

subscriber can receive calling number information and many different responses. Analog Display Services Interface (ADSI) and Spontaneous Call Waiting Identification (SCWID) are CLASS features. The Change Service Orders (SERVORD) can add these features to a line.

### Operation

The ADSI allows the download of softkey and display information to an ADSI compatible CPE from the central control (CC). The static download of feature information to the CLASS Modem Resource (CMR) card in the SMS-R reduces the amount of data that the CC must process in real time. The Calling Number Delivery (CND) feature operates when a normal termination occurs on a line with the CND option. A normal termination is a call. The CC only sends the necessary caller information to the SMS-R.

During the silent interval after the first ring, the SMS-R delivers the calling number. The SMSR also delivers the date and time of the call. The SMS-R delivers this information to customer equipment in an ADSI format through the CMR card. The silent interval after the first ring must be a minimum of 3 s.

The toneset card is on the SMS-R. The toneset card supplies Bellcore-compatible ADSI tones to the CPE. The toneset card applies these tones when the system activates the CLASS features. The universal tone receiver (UTR) card in the SMS-R collects and interprets information tones from the CPE. The placement of most of the CLASS call processing activities on the SMS-R improves response times. The placement also off loads services from the CC.

### Translations table flow

This package does not change standard translations data flow.

### Limits

The CLASS feature requires CPE with ADSI display ability that complies with Bellcore TR-30, TR-575, and TR-1273. The CLASS feature requires CPE to receive and display the calling number information. The CPE that does not comply with the Bellcore requirements can use specified CLASS features. This type of CPE can use the CLASS features that do not depend on the ADSI feature.

You cannot add the CLASS feature SCWID to a line with the Call Hold (CHD) option.



---

## Custom Local Area Signaling Services (continued)

---

You must assign a minimum of one display option to a line before, or at the same time as you assign SCWID. The display options are as follows:

- Calling Name Display (CNAMD)
- Calling Number Display (CND)
- Dialable Directory Number (DDN)

You can assign SCWID to a line that uses the SERVORD package. This action causes the system to assign the Call Waiting Option (CWT) to that line automatically. This event occurs if additional required options are not assigned.

The additional SMS-R hardware requirements to implement the ADSI and SCWID CLASS features that comply with Bellcore are as follows:

- Install the combined messaging and tone generator circuit card with ADSI, NT6X69AD.
- The TONESET field is in the table LTCINV. This field must be set to North American ROM-based toneset with ADSI tone (NORTHAA) when the NTX6X69AD is in use.
- The peripheral processor in the SMS-R must be the type MX77AA unified processor card.
- Install and enter the CLASS Modem Resource (CMR) card, NTX6X78AB. After entry, the system must busy and return to service the CMR to activate the CLASS ADSI compatible features.
- Install and enter the Universal Tone Receiver (UTR). The UTR must be available at call time.

### Interactions

Custom Local Area Signaling Services does not have functionality interactions.

### Activation/deactivation by the end user

Custom Local Area Signaling Services do not require activation or deactivation by the end user.

### Billing

Custom Local Area Signaling Services does not affect billing.

### Station Message Detail Recording

Custom Local Area Signaling Services does not affect Station Message Detail Recording.

## Custom Local Area Signaling Services (continued)

### Datafilling office parameters

Custom Local Area Signaling Services does not affect office parameters.

### Datavill sequence

The tables that require datavill to implement CLASS appear in the following table. The tables appear in the correct entry order.

#### Datavill tables required for CLASS

| Table    | Purpose of table                                                                                                                                                                            |
|----------|---------------------------------------------------------------------------------------------------------------------------------------------------------------------------------------------|
| RCCINV   | Remote Cluster Controller Inventory. This table contains the inventory data for the remote cluster controller (RCC). This table does not contain data on the P-side link assignments.       |
| SOFTKEY  | Softkey. This table defines softkey information of the CPE.                                                                                                                                 |
| TEXTPHRS | Text Phrases. This table contains the text phrases for display on the CPE.                                                                                                                  |
| TEXTLOG  | Logical Display Text. This table contains the logical names of the text phrases.                                                                                                            |
| RESFEAT  | Residential Line Feature. This table contains the assignment of CLASS features for residential (RES) lines.                                                                                 |
| OFCOPT   | Office Option. This table contains data on engineering options for the office. Refer to <i>Office Parameters Reference Manual</i> for information on the effect of CLASS office parameters. |
| RESOFC   | Residential Line CLASS Office Data. This table enables CLASS features globally on a DMS-100 family switch.                                                                                  |

#### Modified tables list

The following tables change to implement CLASS features that comply with ADSI.

#### changes required by ADSI (Sheet 1 of 2)

| Table   | FIELD    | CHANGE                                                                        |
|---------|----------|-------------------------------------------------------------------------------|
| LTCINV  | TONESSET | Changes to include NORTHAA as a valid toneset to support the 6X69AD tone card |
| SOFTKEY | LLABEL   | Increase width of long label field from 7 to 18 characters                    |
|         | SLABEL   | Increase width of short label field from 4 to 7 characters                    |
|         | LINKAGE  | Eliminated                                                                    |

---

**Custom Local Area Signaling Services** (continued)
 

---

**changes required by ADSI (Sheet 2 of 2)**

| <b>Table</b> | <b>FIELD</b>        | <b>CHANGE</b>                                                                                                  |
|--------------|---------------------|----------------------------------------------------------------------------------------------------------------|
| TEXTPHRS     | HL MODE             | Add vector of high light mode subfields are: POSITION, MODE                                                    |
| TEXTLOG      | LRCI                | Add display justification field. The possible values are: CENTER, RIGHT, LEFT, INDENT.                         |
|              | DEFNLIST            | Increase definer vector length from 7 to 8 and expand each vector to include subfields: SOFTKEY, MODE, INDENT. |
| RESFEAT      | FEAT                | Changes to include the ADSI line option to the valid features on RES and IBN lines                             |
| OFCOPT       | VSLE PRESENT        | Changes meaning of boolean to override the ADSI line option                                                    |
|              | ADSI_RAM_BASED TONE | Eliminated                                                                                                     |
| RESOFC       | ACK TONE            | Eliminated                                                                                                     |
|              | DATETIME            | Adds boolean field to activated date and time information ability sent to the CPE                              |

## Custom Local Area Signaling Services (continued)

### Datafilling table RCCINV

Datafill for CLASS for table RCCINV appears in the following table. The fields that apply to CLASS appear in this table. See the data schema section of this document for a description of the other fields.

#### Datafilling table RCCINV

| Field                                                                                                                                                                                                                                                                                                                                                                                                                                                                                                                                                                                                                                                             | Subfield or refinement | Entry                                                                                                                | Explanation and action                                                                                                                                                                                                                                                                                                                                                                                                                            |
|-------------------------------------------------------------------------------------------------------------------------------------------------------------------------------------------------------------------------------------------------------------------------------------------------------------------------------------------------------------------------------------------------------------------------------------------------------------------------------------------------------------------------------------------------------------------------------------------------------------------------------------------------------------------|------------------------|----------------------------------------------------------------------------------------------------------------------|---------------------------------------------------------------------------------------------------------------------------------------------------------------------------------------------------------------------------------------------------------------------------------------------------------------------------------------------------------------------------------------------------------------------------------------------------|
| OPTCARD                                                                                                                                                                                                                                                                                                                                                                                                                                                                                                                                                                                                                                                           |                        | MSG6X69                                                                                                              | Optional Card. The MSG6X69 optional card is the only acceptable entry for this field.                                                                                                                                                                                                                                                                                                                                                             |
| TOSET                                                                                                                                                                                                                                                                                                                                                                                                                                                                                                                                                                                                                                                             |                        | NORTHAA                                                                                                              | Tone Set. Enter the tone set for North American with ADSI.                                                                                                                                                                                                                                                                                                                                                                                        |
| PECS6X45                                                                                                                                                                                                                                                                                                                                                                                                                                                                                                                                                                                                                                                          |                        | 6X45AA,<br>6X45AB,<br>6X45AC,<br>6X45CA,<br>6X45AD,<br>6X45AE,<br>6X45AF,<br>6X45BA,<br>6X45BB,<br>6X45BC,<br>MX77AA | 6X45 product engineering code (PEC). Enter the PEC of the 6X45 card in unit 0 and 1 of the RCC. The PEC entered in each unit must be the card with the minimum firmware abilities in the processor complex of each unit. The PECs listed have increasing firmware abilities.<br><br>For RCO2, the 6X45BC card must be used.<br><br>For RCC2, the PEC is MX77AA.<br><br>For RCC the PEC MX77AA can also be used and is referred to as an RCC plus. |
| <p><b>Note:</b> When you enter data in field C-side link table (CSLNKTAB), make sure the system did not assign message links to the same interface card. When the interface card supports a minimum of two links, separate the message links by the number of links on the interface cards. This action applies to all interface link types. These types include DS-1, DS30, DS30A, or PCM-30. Table control issues a warning if an attempt to assign message links on the same interface card occurs. The assignment of message links to the same interface card can cause an E1 outage if the card fails. An E1 outage is the failure of all message links.</p> |                        |                                                                                                                      |                                                                                                                                                                                                                                                                                                                                                                                                                                                   |

#### Datafill example for table RCCINV

The sample datafill for table RCCINV appears in the following example.

## Custom Local Area Signaling Services (continued)

### MAP example for table RCCINV

```

RCCNAME
ADNUM FRATYPE FRNO SHPOS FLOOR ROW FRPOS EQPEC LOAD
 EXECTAB
 CPM
 CSLNKTAB
ESA INTRASW ADDLMSG
 OPTCARD
TONESET
 PECS6X45 E2LOAD EXTINFO HOST RCC
1
2 RCE 2 4 1 B 0 6X12AA DUMMYLD
(RMM_TERM RSMEX) (KEYSET KSETEX)$
LTC 7
(0) (NILPORT) (2) (3) (7) (11) (12) (13) (14) (18) (19) $
N N N
(UTR15) (UTR16) (MSG6X69)$
NORTHAM
6X45AC 6X45AC NILLOAD N

```

### Datafilling table SOFTKEY

Datafill for CLASS for table SOFTKEY appears in the following table. The fields that apply to CLASS appear in this table. See the data schema section of this document for a description of the other fields.

#### Datafilling table SOFTKEY

| Field  | Subfield or refinement | Entry                           | Explanation and action                                                                                        |
|--------|------------------------|---------------------------------|---------------------------------------------------------------------------------------------------------------|
| SERVID |                        | Vector of 0 to 8 characters     | Service identification. Contains the application service identification of the feature that defines softkeys. |
| DEFNUM |                        | 2-33                            | Definer number. Contains a value of 2 to 33.                                                                  |
| LLABEL |                        | alphanumeric 0 to 18 characters | Long label. String identifier for softkey definer.                                                            |
| SLABEL |                        | Vector of 0 to 7 characters     | Short label. String identifier for softkey definer. Vector of 0 to 7 characters.                              |
| RETURN |                        | Vector of 0 to 14 characters    | Return string vector. Vector of 0 to 14 characters.                                                           |

## Custom Local Area Signaling Services (continued)

### Datavfilling table TEXTPHRS

Datavfill for CLASS for table TEXTPHRS appears in the following table. The fields that apply to CLASS appear in this table. See the data schema section of this document for a description of the other fields.

#### Datavfilling table TEXTPHRS

| Field    | Subfield or refinement | Entry                          | Explanation and action                                                                                    |
|----------|------------------------|--------------------------------|-----------------------------------------------------------------------------------------------------------|
| PHRSNAME |                        | characters                     | Physical phrase name. Field can be 40 characters in length.                                               |
| PHRASE   |                        | characters                     | Physical instructional or prompting text string. Vector of a maximum of 40 characters in single quotes.   |
| HL MODE  | POSITION               | 0 to 40                        | The first subfield specifies the character position of the change. Values in subfield range from 0 to 40. |
|          | MODE                   | Normal, Reverse, Grey, or Bold | Subfield MODE has a range of values of Normal, Reverse, Grey, or Bold.                                    |

### Datavfilling table TEXTLOG

Datavfill for CLASS for table TEXTLOG appears in the following table. The fields that apply to CLASS appear in this table. See the data schema section of this document for a description of the other fields.

#### Datavfilling table TEXTLOG (Sheet 1 of 2)

| Field    | Subfield or refinement | Entry         | Explanation and action                                                            |
|----------|------------------------|---------------|-----------------------------------------------------------------------------------|
| LPHRSKEY |                        | alphanumeric  | Three part key that includes the application name, language, and a display number |
| DISTYPE  |                        | character     | Display type character of set standard, transient, cursor control                 |
| LRCI     |                        | Refer to list | Display justification indicator field center, right, left, Indent                 |

---

## Custom Local Area Signaling Services (continued)

---

**Datafilling table TEXTLOG (Sheet 2 of 2)**

| Field    | Subfield or refinement | Entry         | Explanation and action                                                     |
|----------|------------------------|---------------|----------------------------------------------------------------------------|
| PHRLIST  |                        | character     | Vector of phrase names from the table TEXTPHRS                             |
| DEFNLIST |                        | Refer to list | Vector of softkey definers (softkey (1 to 33), mode (N,H), SKT (SRV, CPE)) |

**Datafilling table RESFEAT**

Datafill for CLASS for table RESFEAT appears in the following table. The fields that apply to CLASS appear in this table. See the data schema section of this document for a description of the other fields.

**Datafilling table RESFEAT**

| Field | Subfield or refinement | Entry        | Explanation and action                                |
|-------|------------------------|--------------|-------------------------------------------------------|
| LINE  |                        | numeric      | External LEN number assigned to a line                |
| KEY   |                        | 0 to 69      | Number that identifies the feature to assign          |
| FEAT  |                        | alphanumeric | CLASS feature name to assign. Values are ADSI, SCWID. |
| VAR   |                        | alphanumeric | Variable area that this feature uses                  |

**Datafilling table OFCOPT**

Datafill for CLASS for table OFCOPT appears in the following table. The fields that apply to CLASS appear in this table. See the data schema section of this document for a description of the other fields.

**Datafilling table OFCOPT**

| Field        | Subfield or refinement | Entry  | Explanation and action                                                                                                                                                                                                                |
|--------------|------------------------|--------|---------------------------------------------------------------------------------------------------------------------------------------------------------------------------------------------------------------------------------------|
| VSLE_PRESENT |                        | N or Y | When set to N (no), the system must assign the ADSI line option to the subscriber line to access visual screen list editing (VSLE). When set to Y (yes), the option allows access to VSLE without the assignment of ADSI to the line. |

## Custom Local Area Signaling Services (end)

---

### Datafilling table RESOFC

Datafill for CLASS for table RESOFC appears in the following table. The fields that apply to CLASS appear in this table. See the data schema section of this document for a description of the other fields.

#### Datafilling table RESOFC

| Field    | Subfield or refinement | Entry  | Explanation and action                                                                                                    |
|----------|------------------------|--------|---------------------------------------------------------------------------------------------------------------------------|
| DATETIME |                        | N or Y | When set to Y, the option allows the transfer of date and time information to the CPE with the calling party information. |

For additional information on CLASS features, refer to the *Translations Guide*.

### Tools for verifying translations

Custom Local Area Signaling Services does not use tools for verifying translations.

### SERVORD

Custom Local Area Signaling Services does not use SERVORD.



## Meridian Digital Centrex Basic

---

### Functional group

MDC0001

### Feature package

NTX100AA Meridian Digital Centrex—Basic

### Release applicability

BCS34 and later versions

### Requirements

Meridian Digital Centrex Basic requires the following feature packages to operate:

- NTX000AA Bilge
- NTX001AA Common Basic
- NTX901AA Local Features I
- NTX398AA Subscriber Carrier Module-100S: Interface to SLC-96 Remote Terminal

### Description

The NTX100AA provides Meridian Digital Centrex Basic features on the Subscriber Carrier Module-100S Remote (SMS-R).

### Operation

The Meridian Digital Centrex (MDC) software is a Central Office (CO) based system. Large and small business customers can use MDC. The MDC software uses a DMS-100 to provide a centralized telephone communications exchange.

The MDC software includes multiple telephone features and services. These features are for customers that a Private Branch Exchange (PBX) can serve.

Software additions to the DMS-100 switch implement the MDC features. Rotary or Digitone telephone sets can access the MDC features.

### Translations table flow

This package does not alter standard translations data flow.

## Meridian Digital Centrex Basic (continued)

---

### Limits

The following limits apply to Meridian Digital Centrex Basic:

- The SMS-R/RCS does not support Meridian Business Sets and data units.
- Trunk units cannot connect to the SMS-R.
- The distinctive ringing feature requires the RCS to have coded ringing.

The following ESA limits apply because of RCC and/or Dual RCC ESA operations:

- Each subtending SMS-R supports a maximum of 32 customer groups.
- The system supports a maximum of eight prefixes or special numbers of 15-digit length for each customer group. Examples of prefixes and special numbers are 0+, 411, 9+ with or without second dial tone.
- The system supports station-to-station dialing for one to six digit extension numbers.
- The system supports direct outward dialing with or without second dial tone. Second dial tone is for termination to another customer group or plain old telephone service (POTS) line in the same RSC.
- The system supports Intercustomer group calling with the same dialing plan. The system does not support lines with denied incoming option.
- The system treats Multiple Appearance Directory Number (MADN) group primary number as a normal IBN line. The MADN lines can originate calls.
- The system supports the IBNXLA translation table selector EXTN for station-to-station dialing. When the user does not enter data in the EXTN selector, the system uses POTS translations.
- The system does not support attendant consoles.
- The system does not support Network Class or Service (NCOS) for IBN.
- The system does not support custom calling features. For example, the system does not recognize and the system does not support conferencing.
- The system does not support Automatic lines (AUL) that originate on one RCC, and terminate on the interconnected RCC.
- The system does not support hunting for calls that originate on one RCC and terminate to a hunt group on the interconnected RCC. The call is complete when the group member associated with the DN is idle.
- The system does not support IBN customer groups, split across the two RCCs.

---

## Meridian Digital Centrex Basic (end)

---

Refer to the *Translations Guide* for additional limits that apply to this package.

### Interactions

Meridian Digital Centrex Basic does not have functionality interactions.

### Activation/deactivation by the end user

Meridian Digital Centrex Basic does not require activation or deactivation by the end user.

### Billing

Meridian Digital Centrex Basic does not affect billing.

### Station Message Detail Recording

Meridian Digital Centrex Basic does not affect Station Message Detail Recording.

### Datafilling office parameters

Meridian Digital Centrex Basic does not affect office parameters.

### Datafill sequence

Refer to *Translations Guide* to identify the datafill sequence and tables that require datafill to implement the feature.

### Tools for verifying translation

Meridian Digital Centrex Basic does not use translation verification tools.

### SERVORD

Meridian Digital Centrex Basic does not use SERVORD.



---

# Index

---

## A

- A- and B-bit signaling Vol. 2, 5-3, Vol. 2, 6-3, Vol. 2, 7-5, Vol. 3, 3-5
- AB bit signaling Vol. 3, 3-11
- activating
  - BAS RSC Vol. 1, 6-30
  - CLASS features Vol. 2, 3-125, Vol. 2, 4-123
  - CLASS-Call Setup Vol. 3, 4-111
  - Custom Local Area Signaling Service Vol. 1, 6-117
  - Dual Remote Cluster Controller Vol. 3, 4-190
  - Dual Remote Cluster Controller (DRCC) Vol. 1, 6-143
  - Emergency Stand-Alone Operation Vol. 1, 5-126
  - ESA call processing Vol. 1, 3-115, Vol. 1, 4-97, Vol. 2, 7-133
  - Firmware Downloading Vol. 1, 6-271
  - firmware downloading Vol. 3, 4-275
  - ISDN on RSC-S Vol. 3, 4-215
  - Meridian Digital Centrex Basic Vol. 2, 3-149, Vol. 3, 5-119
  - New Peripheral Maintenance Package Vol. 1, 6-241
  - OPM Maintenance Vol. 1, 5-152
  - Outside Plant Module Vol. 1, 3-97
  - Remote Line Concentrating Module Vol. 1, 3-13, Vol. 1, 4-13, Vol. 1, 5-11
  - RLCM Intracalling Vol. 1, 3-108, Vol. 1, 4-133, Vol. 1, 5-162
  - RSC Enhanced ESA (Lines and Trunks) Vol. 3, 4-316
  - RSC Enhanced ESA Lines and Trunks Vol. 1, 6-168
  - RSC ESA lines Vol. 1, 6-178
  - RSC Trunking Vol. 1, 6-252
  - RSC-ESA Line and Trunks Vol. 1, 6-201
  - RSC-ESA lines Vol. 3, 4-157
  - RSC-ESA lines and trunks Vol. 3, 4-171
  - RSC-S basic call processing Vol. 3, 4-39
  - RSC-S dynamic trunks Vol. 3, 4-140
  - RSC-S Enhanced ESA for ISDN (Lines and Trunks) Vol. 3, 4-344
  - RSC-S Enhanced ESA for ISDN (Lines Only) Vol. 3, 4-331
  - SCM SLC-96 Basic Vol. 2, 3-22
  - Special Services for Subscriber Carrier Module Vol. 2, 3-151
  - Special Services for Subscriber Carrier Module Remote Vol. 3, 5-99
  - Star Remote Hub basic call processing Vol. 2, 7-26
  - Subscriber Module SLC-96/Remote Vol. 3, 5-22
  - Subscriber Module SLC-96/Remote Vol. 3, 4-290
  - XPM-PLUS Basic Vol. 1, 6-279
- ADSI Vol. 2, 5-3, Vol. 2, 5-10, Vol. 2, 6-3, Vol. 2, 6-11, Vol. 3, 3-5, Vol. 3, 3-21
- ALMSC, table
  - datafilling Vol. 1, 3-64, Vol. 1, 4-64, Vol. 1, 5-56, Vol. 1, 5-88, Vol. 1, 6-105, Vol. 2, 3-79, Vol. 2, 5-91, Vol. 2, 6-84, Vol. 2, 7-99, Vol. 3, 2-45, Vol. 3, 3-107, Vol. 3, 4-97, Vol. 3, 5-67
- ALMSCGRP, table
  - datafilling Vol. 1, 3-64, Vol. 1, 4-64, Vol. 1, 5-54, Vol. 1, 5-87, Vol. 1, 6-103, Vol. 2, 3-75, Vol. 2, 5-89, Vol. 2, 6-82, Vol. 2, 7-97, Vol. 3, 2-43, Vol. 3, 3-105, Vol. 3, 4-94, Vol. 3, 5-63

ALMSD, table

datafilling Vol. 1, 3-66, Vol. 1, 4-66,  
Vol. 1, 5-60, Vol. 1, 5-92, Vol. 1, 6-104,  
Vol. 2, 3-78, Vol. 2, 5-93, Vol. 2, 6-86,  
Vol. 2, 7-101, Vol. 3, 2-47, Vol. 3, 3-109,  
Vol. 3, 4-96, Vol. 3, 5-66

ALMSDGRP, table

datafilling Vol. 1, 3-65, Vol. 1, 4-65,  
Vol. 1, 5-58, Vol. 1, 5-90, Vol. 1, 6-102,  
Vol. 2, 3-76, Vol. 2, 5-90, Vol. 2, 6-83,  
Vol. 2, 7-100, Vol. 3, 2-44, Vol. 3, 3-106,  
Vol. 3, 4-95, Vol. 3, 5-65

AMAOPTS, table

datafilling Vol. 1, 6-117, Vol. 2, 3-125,  
Vol. 2, 4-123, Vol. 2, 5-177, Vol. 2, 6-157,  
Vol. 3, 2-114, Vol. 3, 3-195, Vol. 3, 4-111

Analog Display Services Interface Vol. 2, 5-3,  
Vol. 2, 5-10, Vol. 2, 6-3, Vol. 2, 6-11, Vol. 3, 3-5,  
Vol. 3, 3-21

## B

batteries Vol. 1, 5-151

backup power supply Vol. 1, 5-151  
strings Vol. 1, 5-151

battery charge controller Vol. 1, 5-151

battery control unit Vol. 1, 5-151

BCC Vol. 1, 5-151

BCU Vol. 1, 5-151

billing

BAS RSC Vol. 1, 6-30

CLASS features Vol. 2, 3-125, Vol. 2, 4-123

CLASS-Call Setup Vol. 3, 4-111

Custom Local Area Signaling Service  
Vol. 1, 6-117

Dual Remote Cluster Controller  
Vol. 3, 4-190

Dual Remote Cluster Controller (DRCC)  
Vol. 1, 6-158

Emergency Stand-Alone Operation  
Vol. 1, 5-127

ESA call processing Vol. 1, 3-116,  
Vol. 1, 4-97, Vol. 2, 7-133

Firmware Downloading Vol. 1, 6-271

firmware downloading Vol. 3, 4-275

ISDN on RSC-S Vol. 3, 4-215

Meridian Digital Centrex Basic

Vol. 2, 3-149, Vol. 3, 5-119

New Peripheral Maintenance Package  
Vol. 1, 6-241

OPM Maintenance Vol. 1, 5-152

Outside Plant Module Vol. 1, 3-97

Remote Line Concentrating Module  
Vol. 1, 3-13, Vol. 1, 4-13, Vol. 1, 5-11

RLCM Intracalling Vol. 1, 3-108,  
Vol. 1, 4-133, Vol. 1, 5-162

RSC Enhanced ESA (Lines and Trunks)  
Vol. 3, 4-316

RSC Enhanced ESA Lines and Trunks  
Vol. 1, 6-168

RSC ESA lines Vol. 1, 6-179

RSC Trunking Vol. 1, 6-253

RSC-ESA Line and Trunks Vol. 1, 6-201

RSC-ESA lines Vol. 3, 4-157

RSC-ESA lines and trunks Vol. 3, 4-172

RSC-S basic call processing Vol. 3, 4-39

RSC-S dynamic trunks Vol. 3, 4-140

RSC-S Enhanced ESA for ISDN (Lines and  
Trunks) Vol. 3, 4-344

RSC-S Enhanced ESA for ISDN (Lines  
Only) Vol. 3, 4-331

SCM SLC-96 Basic Vol. 2, 3-22

Special Services for Subscriber Carrier  
Module Vol. 2, 3-151

Special Services for Subscriber Carrier  
Module Remote Vol. 3, 5-99

Star Remote Hub basic call processing  
Vol. 2, 7-26

Subscriber Module SLC-96/Remote  
Vol. 3, 5-22

Subscriber Module SLC-96/Remote  
Vol. 3, 4-290

XPM-PLUS Basic Vol. 1, 6-279

## C

Call Forwarding Vol. 2, 5-44

Call processing

channel allocation Vol. 2, 5-31, Vol. 2, 5-32,  
Vol. 2, 5-34, Vol. 2, 5-35, Vol. 2, 6-30,  
Vol. 2, 6-31, Vol. 2, 6-33, Vol. 3, 3-43,  
Vol. 3, 3-44, Vol. 3, 3-46, Vol. 3, 3-47

- coin operation Vol. 2, 5-38, Vol. 2, 6-36, Vol. 3, 3-49
  - coin collect Vol. 2, 5-38, Vol. 2, 6-36, Vol. 3, 3-50
  - coin partial presence Vol. 2, 5-39, Vol. 2, 6-37, Vol. 3, 3-50
  - coin presence Vol. 2, 5-38, Vol. 2, 6-37, Vol. 3, 3-50
  - coin return Vol. 2, 5-38, Vol. 2, 6-36, Vol. 3, 3-50
  - interactions Vol. 2, 5-39, Vol. 2, 6-37, Vol. 3, 3-51
  - limitations Vol. 2, 5-39, Vol. 2, 6-37, Vol. 3, 3-51
  - normal battery Vol. 2, 5-39, Vol. 2, 6-37, Vol. 3, 3-51
  - reverse battery Vol. 2, 5-39, Vol. 2, 6-37, Vol. 3, 3-50
- loss padding Vol. 2, 5-36, Vol. 2, 6-35, Vol. 3, 3-48
- origination Vol. 2, 5-31, Vol. 2, 5-32, Vol. 2, 5-34, Vol. 2, 5-35, Vol. 2, 6-30, Vol. 2, 6-31, Vol. 2, 6-33, Vol. 3, 3-43, Vol. 3, 3-44, Vol. 3, 3-46, Vol. 3, 3-47
- ringing Vol. 2, 5-35, Vol. 2, 5-36, Vol. 2, 6-34, Vol. 3, 3-47, Vol. 3, 3-48
- tone generation Vol. 2, 5-32, Vol. 2, 5-33, Vol. 2, 5-34, Vol. 2, 5-36, Vol. 2, 5-37, Vol. 2, 6-31, Vol. 2, 6-32, Vol. 2, 6-35, Vol. 3, 3-44, Vol. 3, 3-45, Vol. 3, 3-48, Vol. 3, 3-49
- Call processing (IDT to RDT) Vol. 2, 5-34, Vol. 2, 6-33, Vol. 3, 3-46
  - alerting Vol. 2, 5-35, Vol. 2, 6-34, Vol. 3, 3-47
  - busy service of subscriber lines Vol. 2, 5-38, Vol. 2, 6-36, Vol. 3, 3-49
  - call disconnection Vol. 2, 5-37, Vol. 2, 6-35, Vol. 3, 3-48
  - channel selection Vol. 2, 5-35, Vol. 2, 6-33, Vol. 3, 3-47
  - flash detection Vol. 2, 5-37, Vol. 2, 6-35, Vol. 3, 3-49
  - loss padding Vol. 2, 5-36, Vol. 2, 6-35, Vol. 3, 3-48
  - network busy call treatment Vol. 2, 5-35, Vol. 2, 6-33, Vol. 3, 3-46
  - on#1e>hook transmission Vol. 2, 5-36, Vol. 2, 6-34, Vol. 3, 3-48
  - on-hook transmission
  - CLASS calling number delivery (CND) Vol. 2, 5-36, Vol. 2, 6-35, Vol. 3, 3-48
  - time slot request Vol. 2, 5-34, Vol. 2, 6-33, Vol. 3, 3-46
- Call processing (RDT to IDT) Vol. 2, 5-31, Vol. 2, 6-30, Vol. 3, 3-43
  - busy service of subscriber lines Vol. 2, 5-34, Vol. 2, 6-33, Vol. 3, 3-46
  - channel selection Vol. 2, 5-32, Vol. 2, 6-31, Vol. 3, 3-44
  - disconnecting a call Vol. 2, 5-33, Vol. 2, 6-32, Vol. 3, 3-45
  - flash detection Vol. 2, 5-34, Vol. 2, 6-32, Vol. 3, 3-45
  - sending addressing information Vol. 2, 5-32, Vol. 2, 6-31, Vol. 3, 3-44
  - time slot request Vol. 2, 5-31, Vol. 2, 6-30, Vol. 3, 3-43
  - tone generation Vol. 2, 5-32, Vol. 2, 6-31, Vol. 3, 3-44
- Call processing coin operation Vol. 2, 5-38, Vol. 2, 6-36, Vol. 3, 3-49
  - battery Vol. 2, 5-39, Vol. 2, 6-37, Vol. 3, 3-50
    - normal battery Vol. 2, 5-39, Vol. 2, 6-37, Vol. 3, 3-51
    - reverse battery Vol. 2, 5-39, Vol. 2, 6-37, Vol. 3, 3-50
  - coin commands Vol. 2, 5-38, Vol. 2, 6-36, Vol. 3, 3-49
    - coin collect Vol. 2, 5-38, Vol. 2, 5-39, Vol. 2, 6-36, Vol. 2, 6-37, Vol. 3, 3-50
    - coin presence Vol. 2, 5-38, Vol. 2, 6-37, Vol. 3, 3-50
    - coin return Vol. 2, 5-38, Vol. 2, 6-36, Vol. 3, 3-50
  - subscriber line signaling Vol. 2, 5-39, Vol. 2, 6-37, Vol. 3, 3-51
    - analog Vol. 2, 5-39, Vol. 2, 6-37, Vol. 3, 3-51
    - coin dial#1e>tone first Vol. 2, 5-41, Vol. 2, 6-39, Vol. 3, 3-53
    - coin first Vol. 2, 5-40, Vol. 2, 6-38, Vol. 3, 3-52
    - coin interactions Vol. 2, 5-39, Vol. 2, 6-37, Vol. 3, 3-51
    - coin operation limitations Vol. 2, 5-39, Vol. 2, 6-37, Vol. 3, 3-51
    - coin semi#1e>postpay Vol. 2, 5-42, Vol. 3, 3-53
    - metallic Vol. 2, 5-39, Vol. 2, 6-37, Vol. 3, 3-51

- Call Waiting Vol. 2, 5-43
- Cards
- CMR Vol. 2, 5-45, Vol. 2, 6-40, Vol. 3, 3-56
- CARRMTC, table
- datafilling Vol. 1, 3-39, Vol. 1, 4-39, Vol. 1, 5-36, Vol. 1, 6-57, Vol. 2, 3-29, Vol. 2, 5-80, Vol. 2, 7-56, Vol. 3, 4-61, Vol. 3, 4-230, Vol. 3, 5-29
- CILLI, table
- datafilling Vol. 3, 5-25
- CLASS Vol. 2, 5-45, Vol. 2, 6-40, Vol. 3, 3-56
- CLLI, table
- datafilling Vol. 3, 4-42
- CLLI, table
- datafilling Vol. 1, 3-22, Vol. 1, 4-22, Vol. 1, 5-21, Vol. 1, 6-38, Vol. 1, 6-203, Vol. 1, 6-254, Vol. 2, 3-25, Vol. 2, 5-67, Vol. 2, 7-31, Vol. 3, 4-218
- CLLIMTCE, table
- datafilling Vol. 1, 3-63, Vol. 1, 4-63, Vol. 1, 5-54, Vol. 1, 5-86, Vol. 2, 7-97
- CND Vol. 2, 5-45, Vol. 2, 6-40, Vol. 3, 3-56
- Coin Vol. 2, 5-31, Vol. 2, 5-40, Vol. 2, 6-30, Vol. 2, 6-38, Vol. 3, 3-43, Vol. 3, 3-52
- call processing
    - coin commands Vol. 2, 5-38, Vol. 2, 6-36, Vol. 3, 3-49
  - coin collect Vol. 2, 5-38, Vol. 2, 6-36, Vol. 3, 3-50
  - coin first Vol. 2, 5-40, Vol. 2, 6-38, Vol. 3, 3-52
  - coin partial presence Vol. 2, 5-39, Vol. 2, 6-37, Vol. 3, 3-50
  - coin presence Vol. 2, 5-38, Vol. 2, 6-37, Vol. 3, 3-50
  - coin return Vol. 2, 5-38, Vol. 2, 6-36, Vol. 3, 3-50
  - dial tone first Vol. 2, 5-41, Vol. 2, 6-39, Vol. 3, 3-53
  - limitations and interactions Vol. 2, 5-39, Vol. 2, 6-37, Vol. 3, 3-51
  - normal battery Vol. 2, 5-39, Vol. 2, 6-37, Vol. 3, 3-51
  - operation Vol. 2, 5-38, Vol. 2, 6-36, Vol. 3, 3-49
  - reverse battery Vol. 2, 5-39, Vol. 2, 6-37, Vol. 3, 3-50
  - semi-postpay Vol. 2, 5-42, Vol. 3, 3-53
- Coin service
- types Vol. 2, 5-40, Vol. 2, 6-38, Vol. 3, 3-52
- Coin services
- coin
    - coin first Vol. 2, 5-40, Vol. 2, 6-38, Vol. 3, 3-52
    - dial tone first Vol. 2, 5-41, Vol. 2, 6-39, Vol. 3, 3-53
  - coin services
    - coin
      - semi#1e>postpay Vol. 2, 5-42, Vol. 3, 3-53
- Communication protocol Vol. 2, 7-10
- Communication protocols Vol. 2, 6-16
- Compact peripheral module Vol. 3, 3-2
- CPM Vol. 3, 3-2
- CSC Vol. 2, 5-32, Vol. 2, 5-34, Vol. 3, 3-43, Vol. 3, 3-46
- LAPD Vol. 2, 5-14, Vol. 3, 3-25
  - message descriptions
    - alerting Vol. 2, 5-22, Vol. 3, 3-34
    - disconnect Vol. 2, 5-23, Vol. 3, 3-35
    - notify Vol. 2, 5-23, Vol. 3, 3-35
    - setup acknowledge Vol. 2, 5-23, Vol. 3, 3-35
  - path protection Vol. 2, 5-6, Vol. 2, 5-7, Vol. 2, 6-9, Vol. 3, 3-17, Vol. 3, 3-18
  - Q.921 Vol. 2, 5-14, Vol. 3, 3-25
  - Q.931 Vol. 2, 5-14, Vol. 3, 3-25
- CUSTHEAD ( MDC only), table
- datafilling Vol. 1, 6-221
- CUSTHEAD table
- datafilling Vol. 3, 4-179
- CUSTHEAD, table
- DATAFILLING Vol. 3, 4-351
  - datafilling Vol. 1, 3-136, Vol. 1, 4-117, Vol. 1, 5-148, Vol. 1, 6-191, Vol. 2, 7-149, Vol. 3, 4-164, Vol. 3, 4-323, Vol. 3, 4-337
- Custom calling Vol. 2, 5-43
- D**
- data tables
- overview Vol. 1, 2-1, Vol. 2, 2-1, Vol. 3, 2-1
  - structure
    - illustration Vol. 1, 2-2, Vol. 2, 2-2, Vol. 3, 2-2
- Data-enhanced bus interface card
- protocol Vol. 2, 7-16



- Datafill sequence  
 Subscriber Carrier Module-100 Access  
 Vol. 2, 5-63
- datafill sequence  
 BAS RSC Vol. 1, 6-31  
 CLASS features Vol. 2, 3-127, Vol. 2, 4-125  
 CLASS-Call Setup Vol. 3, 4-113  
 Custom Local Area Signaling Service  
 Vol. 1, 6-119  
 Dual Remote Cluster Controller  
 Vol. 3, 4-191  
 Dual Remote Cluster Controller (DRCC)  
 Vol. 1, 6-158  
 Emergency Stand-Alone Operation  
 Vol. 1, 5-133  
 ESA call processing Vol. 1, 3-122,  
 Vol. 1, 4-104, Vol. 2, 7-139  
 Firmware Downloading Vol. 1, 6-272  
 firmware downloading Vol. 3, 4-276  
 ISDN on RSC-S Vol. 3, 4-215  
 Meridian Digital Centrex Basic  
 Vol. 2, 3-149, Vol. 3, 5-119  
 New Peripheral Maintenance Package  
 Vol. 1, 6-241  
 OPM Maintenance Vol. 1, 5-158  
 Outside Plant Module Vol. 1, 3-102  
 Remote Line Concentrating Module  
 Vol. 1, 3-18, Vol. 1, 4-18, Vol. 1, 5-16  
 RLCM Intracalling Vol. 1, 3-108,  
 Vol. 1, 4-133, Vol. 1, 5-163  
 RSC Enhanced ESA (Lines and Trunks)  
 Vol. 3, 4-317  
 RSC Enhanced ESA Lines and Trunks  
 Vol. 1, 6-169  
 RSC ESA lines Vol. 1, 6-183  
 RSC Trunking Vol. 1, 6-253  
 RSC-ESA Line and Trunks Vol. 1, 6-202  
 RSC-ESA lines Vol. 3, 4-157  
 RSC-ESA lines and trunks Vol. 3, 4-172  
 RSC-S basic call processing Vol. 3, 4-40  
 RSC-S dynamic trunks Vol. 3, 4-140  
 RSC-S Enhanced ESA for ISDN (Lines and  
 Trunks) Vol. 3, 4-345  
 RSC-S Enhanced ESA for ISDN (Lines  
 Only) Vol. 3, 4-332  
 SCM SLC-96 Basic Vol. 2, 3-22  
 Special Services for Subscriber Carrier  
 Module Vol. 2, 3-151  
 Special Services for Subscriber Carrier  
 Module Remote Vol. 3, 5-100  
 Star Remote Hub basic call processing  
 Vol. 2, 7-27  
 Subscriber Module SLC-96/Remote  
 Vol. 3, 5-22  
 Subscriber Module SLC-96/Remote  
 Vol. 3, 4-291  
 XPM-PLUS Basic Vol. 1, 6-279
- datafilling  
 nonprompting mode Vol. 1, 2-4, Vol. 2, 2-4,  
 Vol. 3, 2-4  
 procedures Vol. 1, 2-3, Vol. 2, 2-3, Vol. 3, 2-3  
 prompts and prompting mode Vol. 1, 2-3,  
 Vol. 2, 2-3, Vol. 3, 2-3
- DATASIZE, table  
 datafilling Vol. 1, 3-21, Vol. 1, 4-22,  
 Vol. 1, 5-21, Vol. 2, 7-31, Vol. 3, 4-218
- DCHINV, table  
 datafilling Vol. 2, 5-95, Vol. 3, 4-246
- deactivating  
 BAS RSC Vol. 1, 6-30  
 CLASS features Vol. 2, 3-125, Vol. 2, 4-123  
 CLASS-Call Setup Vol. 3, 4-111  
 Custom Local Area Signaling Service  
 Vol. 1, 6-117  
 Dual Remote Cluster Controller  
 Vol. 3, 4-190  
 Dual Remote Cluster Controller (DRCC)  
 Vol. 1, 6-143  
 Emergency Stand-Alone Operation  
 Vol. 1, 5-126  
 ESA call processing Vol. 1, 3-115,  
 Vol. 1, 4-97, Vol. 2, 7-133  
 Firmware Downloading Vol. 1, 6-271  
 firmware downloading Vol. 3, 4-275  
 ISDN on RSC-S Vol. 3, 4-215  
 Meridian Digital Centrex Basic  
 Vol. 2, 3-149, Vol. 3, 5-119  
 OPM Maintenance Vol. 1, 5-152  
 Outside Plant Module Vol. 1, 3-97  
 Remote Line Concentrating Module  
 Vol. 1, 3-13, Vol. 1, 4-13, Vol. 1, 5-11  
 RLCM Intracalling Vol. 1, 3-108,  
 Vol. 1, 4-133, Vol. 1, 5-162

- RSC Enhanced ESA (Lines and Trunks)  
Vol. 3, 4-316
- RSC Enhanced ESA Lines and Trunks  
Vol. 1, 6-168
- RSC ESA lines Vol. 1, 6-178
- RSC Trunking Vol. 1, 6-252
- RSC-ESA Line and Trunks Vol. 1, 6-201
- RSC-ESA lines Vol. 3, 4-157
- RSC-ESA lines and trunks Vol. 3, 4-171
- RSC-S basic call processing Vol. 3, 4-39
- RSC-S dynamic trunks Vol. 3, 4-140
- RSC-S Enhanced ESA for ISDN (Lines and Trunks) Vol. 3, 4-344
- RSC-S Enhanced ESA for ISDN (Lines Only) Vol. 3, 4-331
- SCM SLC-96 Basic Vol. 2, 3-22
- Special Services for Subscriber Carrier Module Vol. 2, 3-151
- Special Services for Subscriber Carrier Module Remote Vol. 3, 5-99
- Star Remote Hub basic call processing  
Vol. 2, 7-26
- Subscriber Module SLC-96/Remote  
Vol. 3, 5-22
- Subscriber Module SLC-96/Remote  
Vol. 3, 4-290
- XPM-PLUS Basic Vol. 1, 6-279
- Description
  - Subscriber Carrier Module-100 Access  
Vol. 2, 5-60
- description
  - BAS RSC Vol. 1, 6-14
  - CLASS features Vol. 2, 3-121, Vol. 2, 4-121
  - CLASS-Call Setup Vol. 3, 4-109
  - Custom Local Area Signaling Service  
Vol. 1, 6-114
  - Dual Remote Cluster Controller  
Vol. 3, 4-185
  - Dual Remote Cluster Controller (DRCC)  
Vol. 1, 6-140
  - Emergency Stand-Alone Operation  
Vol. 1, 5-124
  - ESA call processing Vol. 1, 3-112,  
Vol. 1, 4-94, Vol. 2, 7-129
  - Firmware Downloading Vol. 1, 6-267
  - firmware downloading Vol. 3, 4-271
  - ISDN on RSC-S Vol. 3, 4-201
  - Meridian Digital Centrex Basic  
Vol. 2, 3-148, Vol. 3, 5-117
  - New Peripheral Maintenance Package  
Vol. 1, 6-236
  - OPM Maintenance Vol. 1, 5-150
  - Outside Plant Module Vol. 1, 3-95
  - Remote Line Concentrating Module  
Vol. 1, 3-11, Vol. 1, 4-11, Vol. 1, 5-10
  - RLCM Intracalling Vol. 1, 3-106,  
Vol. 1, 4-131, Vol. 1, 5-161
  - RSC Enhanced ESA (Lines and Trunks)  
Vol. 3, 4-311
  - RSC Enhanced ESA Lines and Trunks  
Vol. 1, 6-164
  - RSC ESA lines Vol. 1, 6-175
  - RSC Trunking Vol. 1, 6-246
  - RSC-ESA Line and Trunks Vol. 1, 6-193
  - RSC-ESA lines Vol. 3, 4-149
  - RSC-ESA lines and trunks Vol. 3, 4-166
  - RSC-S basic call processing Vol. 3, 4-22
  - RSC-S dynamic trunks Vol. 3, 4-135
  - RSC-S Enhanced ESA for ISDN (Lines and Trunks) Vol. 3, 4-339
  - RSC-S Enhanced ESA for ISDN (Lines Only) Vol. 3, 4-328
  - SCM SLC-96 Basic Vol. 2, 3-19
  - Special Services for Subscriber Carrier Module Vol. 2, 3-150
  - Special Services for Subscriber Carrier Module Remote Vol. 3, 5-98
  - Star Remote Hub basic call processing  
Vol. 2, 7-20
  - Subscriber Module SLC-96/Remote  
Vol. 3, 5-21
  - Subscriber Module SLC-96/Remote  
Vol. 3, 4-288
  - XPM-PLUS Basic Vol. 1, 6-278
- DFINV, table
  - datafilling Vol. 1, 3-67, Vol. 1, 4-67,  
Vol. 1, 5-62, Vol. 1, 5-93, Vol. 2, 7-102
- Dial pulse Vol. 2, 5-49, Vol. 2, 6-43, Vol. 3, 3-60
- Dialing Vol. 2, 5-49, Vol. 2, 6-43, Vol. 3, 3-60
  - dial pulse Vol. 2, 5-49, Vol. 2, 6-43, Vol. 3, 3-60
- DTMF Vol. 2, 5-49, Vol. 2, 6-43, Vol. 3, 3-60
- Direct outward dialing
  - PBX
    - DOD Vol. 2, 5-47, Vol. 2, 6-41, Vol. 3, 3-58

- DMS-X handshaking protocol  
 illustration Vol. 1, 3-4, Vol. 1, 4-4
- DMS-X message format  
 illustration Vol. 1, 3-5, Vol. 1, 4-5
- DNROUTE, table  
 datafilling Vol. 1, 3-78, Vol. 1, 4-78,  
 Vol. 1, 5-70, Vol. 1, 5-102, Vol. 2, 7-113
- DS-1 Vol. 3, 3-45  
 facilities Vol. 2, 5-6, Vol. 2, 5-7, Vol. 2, 6-8,  
 Vol. 3, 3-16, Vol. 3, 3-17, Vol. 3, 3-18  
 frame Vol. 2, 5-6, Vol. 3, 3-17  
 frame format Vol. 2, 5-3, Vol. 2, 6-3,  
 Vol. 2, 7-5, Vol. 3, 3-5  
 lines Vol. 2, 5-3, Vol. 2, 6-3, Vol. 2, 7-5,  
 Vol. 3, 3-5
- DS#1e>1 Vol. 2, 5-33, Vol. 2, 6-32  
 facilities Vol. 2, 6-9
- DSCWDTYP, table  
 datafilling Vol. 1, 6-133, Vol. 2, 3-133,  
 Vol. 2, 4-131, Vol. 2, 5-183, Vol. 2, 6-164,  
 Vol. 3, 2-119, Vol. 3, 3-202, Vol. 3, 4-120
- Dual-tone multifrequency Vol. 2, 5-32,  
 Vol. 2, 5-49, Vol. 2, 6-31, Vol. 2, 6-43, Vol. 3, 3-44,  
 Vol. 3, 3-60
- ## E
- Electronic Business Set Vol. 2, 5-43
- Embedded Operations Channel Vol. 2, 5-14,  
 Vol. 2, 6-16, Vol. 3, 3-25
- Enhanced 800/Service switching point  
 Vol. 2, 5-48, Vol. 2, 6-41, Vol. 3, 3-58
- environmental control equipment Vol. 1, 5-151
- EOC  
 applications router Vol. 2, 5-24, Vol. 2, 5-27,  
 Vol. 2, 6-23, Vol. 2, 6-26, Vol. 3, 3-36, Vol. 3, 3-39  
 communication protocol  
 functional areas Vol. 2, 5-25, Vol. 2, 6-24,  
 Vol. 3, 3-37  
 LAPD Vol. 2, 5-14, Vol. 2, 6-16, Vol. 3, 3-25  
 message signaling Vol. 2, 5-7, Vol. 2, 6-9,  
 Vol. 3, 3-18  
 operation entities Vol. 2, 5-24, Vol. 2, 5-27,  
 Vol. 2, 6-23, Vol. 2, 6-26, Vol. 3, 3-36, Vol. 3, 3-39  
 protocol stack Vol. 2, 5-24, Vol. 2, 5-27,  
 Vol. 2, 6-23, Vol. 2, 6-25, Vol. 3, 3-36, Vol. 3, 3-38  
 Q.921 Vol. 2, 5-14, Vol. 2, 6-16, Vol. 3, 3-25
- ESAHNPA table  
 datafilling Vol. 3, 4-182
- ESAHNPA, table  
 DATAFILLING Vol. 3, 4-352  
 datafilling Vol. 1, 6-219, Vol. 3, 4-325
- ESAPXLA table  
 datafilling Vol. 3, 4-176
- ESAPXLA, table  
 DATAFILLING Vol. 3, 4-349  
 datafilling Vol. 1, 3-126, Vol. 1, 4-107,  
 Vol. 1, 5-137, Vol. 1, 6-185, Vol. 1, 6-216,  
 Vol. 2, 7-141, Vol. 3, 4-161, Vol. 3, 4-320,  
 Vol. 3, 4-335
- ESARTE table  
 datafilling Vol. 3, 4-182
- ESARTE, table  
 datafilling Vol. 1, 6-215, Vol. 3, 4-325
- ESF Vol. 2, 5-4, Vol. 2, 6-4, Vol. 2, 7-7, Vol. 3, 3-8  
 CRC Vol. 2, 5-4, Vol. 2, 6-4, Vol. 2, 7-8,  
 Vol. 3, 3-8  
 FDL Vol. 2, 5-4, Vol. 2, 6-4, Vol. 2, 7-7,  
 Vol. 3, 3-8  
 FPS Vol. 2, 5-4, Vol. 2, 6-4, Vol. 2, 7-7,  
 Vol. 3, 3-8
- Essential Line Services  
 Residential  
 ELS Vol. 2, 5-47, Vol. 2, 6-41, Vol. 3, 3-58
- Expanded Subscriber Carrier Module-100 Access  
 automatic maintenance  
 path protection switching Vol. 3, 3-24  
 description  
 coin call messages Vol. 3, 3-54  
 Meridian business set (MBS) messaging  
 Vol. 3, 3-54  
 protocol  
 DS30 Vol. 3, 3-25  
 EOC Vol. 3, 3-25  
 Q.921 Vol. 3, 3-25  
 Q.931 Vol. 3, 3-25  
 protocols  
 DS30 Vol. 3, 3-39  
 signaling  
 DS30 protocol Vol. 3, 3-41
- SMA system  
 description Vol. 3, 3-3

Expanded Subscriber Carrier Module-100 Access (ESMA)

operation Vol. 3, 3-71

Extended superframe format (ESF) signaling

Vol. 2, 5-3, Vol. 2, 7-7

## F

Feature package

NTX146AA Vol. 1, 5-10

NTX147AB Vol. 1, 3-95, Vol. 1, 5-150

NTX154AA Vol. 1, 3-112, Vol. 1, 4-94,  
Vol. 1, 5-124

NTX156AA Vol. 1, 3-106, Vol. 1, 4-131,  
Vol. 1, 5-161

NTX387AC Vol. 2, 4-24

NTX387AD Vol. 2, 4-24

NTXF46AA Vol. 3, 3-70

NTXS02AA Vol. 2, 6-51

NTXT23AA Vol. 3, 2-7

feature package

NTX621AB Vol. 2, 4-142

Frame format

DS-1 Vol. 2, 5-3, Vol. 2, 6-3, Vol. 2, 7-5,  
Vol. 3, 3-5

Functional group

BAS00012 Vol. 1, 5-10, Vol. 1, 5-124,  
Vol. 1, 5-150, Vol. 1, 5-161

BAS0003 Vol. 3, 3-70

SMA00001 Vol. 2, 6-51, Vol. 3, 2-7

functional group

BAS00016 Vol. 2, 4-24, Vol. 2, 4-142

FXS signaling Vol. 3, 3-10

## H

HNPACONT.HNPACODE, subtable

datafilling Vol. 1, 5-71, Vol. 1, 5-103

HNPACONT.HNPACODE, table

datafilling Vol. 1, 3-79, Vol. 1, 4-79,  
Vol. 2, 7-114

HUNTGRP, table

datafilling Vol. 1, 3-73, Vol. 1, 4-73,  
Vol. 2, 7-108

HUNTMEM, table

datafilling Vol. 1, 3-78, Vol. 1, 4-78,  
Vol. 2, 7-113

## I

ICB

signaling

FXS Vol. 3, 3-10

IDT Vol. 2, 5-12, Vol. 2, 5-32, Vol. 2, 5-33,  
Vol. 2, 5-35, Vol. 2, 5-36, Vol. 2, 5-37, Vol. 2, 6-14,  
Vol. 2, 6-31, Vol. 2, 6-32, Vol. 2, 6-33, Vol. 2, 6-34,  
Vol. 2, 6-35, Vol. 3, 3-23, Vol. 3, 3-44, Vol. 3, 3-45,  
Vol. 3, 3-47, Vol. 3, 3-48

Interactions

Subscriber Carrier Module-100 Access  
Vol. 2, 5-62

interactions

BAS RSC Vol. 1, 6-30

CLASS features Vol. 2, 3-125, Vol. 2, 4-123

CLASS-Call Setup Vol. 3, 4-111

Custom Local Area Signaling Service  
Vol. 1, 6-117

Dual Remote Cluster Controller

Vol. 3, 4-190

Dual Remote Cluster Controller (DRCC)

Vol. 1, 6-143

Emergency Stand-Alone Operation  
Vol. 1, 5-126

ESA call processing Vol. 1, 3-115,  
Vol. 1, 4-97, Vol. 2, 7-132

Firmware Downloading Vol. 1, 6-271

firmware downloading Vol. 3, 4-275

ISDN on RSC-S Vol. 3, 4-215

Meridian Digital Centrex Basic

Vol. 2, 3-149, Vol. 3, 5-119

New Peripheral Maintenance Package  
Vol. 1, 6-241

OPM Maintenance Vol. 1, 5-152

Outside Plant Module Vol. 1, 3-97

Remote Line Concentrating Module

Vol. 1, 3-12, Vol. 1, 4-12, Vol. 1, 5-11

RLCM Intracalling Vol. 1, 3-107,

Vol. 1, 4-132, Vol. 1, 5-162

RSC Enhanced ESA (Lines and Trunks)

Vol. 3, 4-316

RSC Enhanced ESA Lines and Trunks

Vol. 1, 6-168

RSC ESA lines Vol. 1, 6-178

RSC Trunking Vol. 1, 6-252

RSC-ESA Line and Trunks Vol. 1, 6-201

- RSC-ESA lines Vol. 3, 4-156  
RSC-ESA lines and trunks Vol. 3, 4-171  
RSC-S basic call processing Vol. 3, 4-39  
RSC-S dynamic trunks Vol. 3, 4-140  
RSC-S Enhanced ESA for ISDN (Lines and Trunks) Vol. 3, 4-344  
RSC-S Enhanced ESA for ISDN (Lines Only) Vol. 3, 4-331  
SCM SLC-96 Basic Vol. 2, 3-22  
Special Services for Subscriber Carrier Module Vol. 2, 3-151  
Special Services for Subscriber Carrier Module Remote Vol. 3, 5-99  
Star Remote Hub basic call processing Vol. 2, 7-26  
Subscriber Module SLC-96/Remote Vol. 3, 5-22  
Subscriber Module SLC-96/Remote Vol. 3, 4-290  
XPM-PLUS Basic Vol. 1, 6-279
- IRLNKINV**, table  
datafilling Vol. 1, 6-160, Vol. 1, 6-171, Vol. 3, 4-196
- ISGDEF**, table  
datafilling Vol. 2, 5-97, Vol. 2, 7-77, Vol. 3, 4-247
- ISTRKGRP** table  
datafilling Vol. 3, 4-181
- ISTRKGRP**, table  
datafilling Vol. 1, 6-209, Vol. 1, 6-261, Vol. 3, 4-147, Vol. 3, 4-324
- K**
- KSETFEAT**, table  
datafilling Vol. 3, 4-263
- KSETINV**, table  
datafilling Vol. 3, 4-259
- KSETLINE**, table  
datafilling Vol. 3, 4-261
- L**
- LAPD** Vol. 2, 5-14, Vol. 2, 6-16, Vol. 2, 7-10, Vol. 3, 3-25  
**CSC** Vol. 2, 5-14, Vol. 3, 3-25  
**EOC** Vol. 2, 5-14, Vol. 2, 6-16, Vol. 3, 3-25  
**TMC** Vol. 2, 6-16, Vol. 3, 3-25
- LCASCRCN.LCASCRCN**, subtable  
datafilling Vol. 1, 5-45
- LCASCRCN.LCASCRCN**, table  
datafilling Vol. 1, 3-55, Vol. 1, 4-55, Vol. 2, 7-87
- LCMINV**, table  
datafilling Vol. 1, 3-45, Vol. 1, 3-108, Vol. 1, 3-123, Vol. 1, 4-45, Vol. 1, 4-104, Vol. 1, 4-133, Vol. 1, 5-40, Vol. 1, 5-134, Vol. 1, 5-163, Vol. 1, 6-82, Vol. 2, 7-62, Vol. 2, 7-69, Vol. 2, 7-140, Vol. 3, 4-79, Vol. 3, 4-244
- LENFEAT**, table  
datafilling Vol. 1, 3-77, Vol. 1, 4-77, Vol. 2, 3-95, Vol. 2, 7-112
- LENLINES**, table  
datafilling Vol. 1, 3-74, Vol. 1, 4-74, Vol. 2, 3-91, Vol. 2, 7-109
- Limitations**  
**Subscriber Carrier Module-100 Access**  
Vol. 2, 5-62
- limitations**  
**BAS RSC** Vol. 1, 6-30  
**CLASS features** Vol. 2, 3-123, Vol. 2, 4-122  
**CLASS-Call Setup** Vol. 3, 4-110  
**Custom Local Area Signaling Service**  
Vol. 1, 6-116  
**Dual Remote Cluster Controller**  
Vol. 3, 4-188  
**Dual Remote Cluster Controller (DRCC)**  
Vol. 1, 6-142  
**Emergency Stand-Alone Operation**  
Vol. 1, 5-126  
**ESA call processing** Vol. 1, 3-115, Vol. 1, 4-96, Vol. 2, 7-131  
**Firmware Downloading** Vol. 1, 6-271  
**firmware downloading** Vol. 3, 4-275  
**ISDN on RSC-S** Vol. 3, 4-215  
**Meridian Digital Centrex Basic**  
Vol. 2, 3-148, Vol. 3, 5-118  
**New Peripheral Maintenance Package**  
Vol. 1, 6-241  
**OPM Maintenance** Vol. 1, 5-152  
**Outside Plant Module** Vol. 1, 3-97  
**Remote Line Concentrating Module**  
Vol. 1, 3-12, Vol. 1, 4-12, Vol. 1, 5-10

- RLCM Intracalling Vol. 1, 3-107,  
Vol. 1, 4-132, Vol. 1, 5-162
  - RSC Enhanced ESA (Lines and Trunks)  
Vol. 3, 4-315
  - RSC Enhanced ESA Lines and Trunks  
Vol. 1, 6-167
  - RSC ESA lines Vol. 1, 6-178
  - RSC Trunking Vol. 1, 6-252
  - RSC-ESA Line and Trunks Vol. 1, 6-200
  - RSC-ESA lines Vol. 3, 4-156
  - RSC-ESA lines and trunks Vol. 3, 4-171
  - RSC-S basic call processing Vol. 3, 4-39
  - RSC-S dynamic trunks Vol. 3, 4-139
  - RSC-S Enhanced ESA for ISDN (Lines and  
Trunks) Vol. 3, 4-344
  - RSC-S Enhanced ESA for ISDN (Lines  
Only) Vol. 3, 4-330
  - SCM SLC-96 Basic Vol. 2, 3-21
  - Special Services for Subscriber Carrier  
Module Vol. 2, 3-151
  - Special Services for Subscriber Carrier  
Module Remote Vol. 3, 5-99
  - Star Remote Hub basic call processing  
Vol. 2, 7-22
  - Subscriber Module SLC-96/Remote  
Vol. 3, 5-21
  - Subscriber Module SLC-96/Remote  
Vol. 3, 4-290
  - XPM-PLUS Basic Vol. 1, 6-279
  - LINEATTR, table  
datafilling Vol. 1, 3-70, Vol. 1, 4-70,  
Vol. 1, 5-65, Vol. 1, 5-97, Vol. 2, 5-142,  
Vol. 2, 7-103
  - Link access procedure on the D#1e>channel  
Vol. 2, 5-14, Vol. 2, 6-16, Vol. 3, 3-25
  - LNINV, table  
datafilling Vol. 1, 3-71, Vol. 1, 4-71,  
Vol. 1, 5-66, Vol. 1, 5-98, Vol. 2, 3-84,  
Vol. 2, 3-151, Vol. 2, 5-146, Vol. 2, 7-105,  
Vol. 3, 3-166, Vol. 3, 4-86, Vol. 3, 4-252,  
Vol. 3, 5-71, Vol. 3, 5-100
  - Loss padding Vol. 2, 5-36, Vol. 2, 6-35,  
Vol. 3, 3-48
  - LTCINV, table  
datafilling Vol. 1, 3-31, Vol. 1, 4-32,  
Vol. 1, 5-30, Vol. 1, 6-53, Vol. 1, 6-242,  
Vol. 1, 6-274, Vol. 2, 3-45, Vol. 2, 3-127,  
Vol. 2, 4-126, Vol. 2, 5-75, Vol. 2, 7-39,  
Vol. 3, 4-56, Vol. 3, 4-225, Vol. 3, 4-282,  
Vol. 3, 4-298
  - LTCPSINV, table  
datafilling Vol. 1, 3-36, Vol. 1, 4-36,  
Vol. 1, 5-34, Vol. 1, 6-62, Vol. 2, 3-51,  
Vol. 2, 5-87, Vol. 2, 7-44, Vol. 3, 4-66,  
Vol. 3, 4-232
  - LTCRINV, table  
datafilling Vol. 3, 4-304, Vol. 3, 5-40
  - LTCRPINV, table  
datafilling Vol. 3, 5-44
  - LTDEF, table  
datafilling Vol. 2, 4-81, Vol. 2, 5-100,  
Vol. 2, 7-81, Vol. 3, 4-254
  - LTDSO, table  
datafilling Vol. 2, 5-166
  - LTGRP, table  
datafilling Vol. 2, 5-99, Vol. 2, 7-80,  
Vol. 3, 4-251
  - LTMAP, table  
datafilling Vol. 3, 4-262
- M**
- MADN  
extension bridging Vol. 2, 5-46, Vol. 3, 3-57  
multi-bridged arrangement Vol. 2, 5-46,  
Vol. 3, 3-56  
multi-call arrangement Vol. 2, 5-46,  
Vol. 3, 3-56  
single bridged arrangement Vol. 2, 5-46,  
Vol. 3, 3-57  
single call arrangement Vol. 2, 5-46,  
Vol. 3, 3-56
  - MBS on AccessNode Vol. 3, 3-55
  - MBS on MVI RDT Vol. 3, 3-55
  - MDC Vol. 2, 5-35, Vol. 2, 5-45, Vol. 2, 5-47,  
Vol. 2, 6-34, Vol. 2, 6-40, Vol. 3, 3-47, Vol. 3, 3-56,  
Vol. 3, 3-57
  - Media access control address  
Ethernet support Vol. 2, 7-16
  - Meridian business set (MBS)  
messaging Vol. 2, 5-44, Vol. 3, 3-54
  - Meridian Digital Centrex Vol. 2, 5-35,  
Vol. 2, 5-45, Vol. 2, 6-34, Vol. 2, 6-40, Vol. 3, 3-47,  
Vol. 3, 3-56

- Residential  
MDC Vol. 2, 5-47, Vol. 2, 6-41, Vol. 3, 3-58
- MTAHORIZ, table  
datafilling Vol. 1, 3-84, Vol. 1, 4-84,  
Vol. 1, 5-75, Vol. 1, 5-109, Vol. 1, 6-99,  
Vol. 2, 3-102, Vol. 2, 5-173, Vol. 2, 7-118,  
Vol. 3, 4-103, Vol. 3, 5-83
- MTAMDRVE, table  
datafilling Vol. 1, 3-80, Vol. 1, 4-80,  
Vol. 1, 5-72, Vol. 1, 5-104, Vol. 1, 6-94,  
Vol. 2, 3-97, Vol. 2, 5-168, Vol. 2, 7-115,  
Vol. 3, 4-99, Vol. 3, 5-78
- MTAVERT, table  
datafilling Vol. 1, 3-84, Vol. 1, 4-84,  
Vol. 1, 5-74, Vol. 1, 5-108, Vol. 1, 6-97,  
Vol. 2, 3-100, Vol. 2, 5-171, Vol. 2, 7-117,  
Vol. 3, 4-102, Vol. 3, 5-81
- Multiple Appearance Directory Number  
MADN  
off#1e>premise extension Vol. 2, 5-47,  
Vol. 2, 6-40, Vol. 3, 3-57
- Multiple Appearance Directory Number  
(MADN) Vol. 2, 5-46, Vol. 3, 3-56
- Multi-vendor interface Vol. 3, 3-5
- MVI Vol. 3, 3-1, Vol. 3, 3-5  
TMC message signaling Vol. 2, 6-8,  
Vol. 3, 3-16
- N**
- NUMDIGS, table  
datafilling Vol. 2, 7-104
- O**
- OFCENG, table  
datafilling Vol. 1, 6-37
- OFCVAR, table  
datafilling Vol. 1, 6-33
- Office parameters  
Subscriber Carrier Module-100 Access  
Vol. 2, 5-63
- office parameters  
BAS RSC Vol. 1, 6-31  
CLASS features Vol. 2, 3-126, Vol. 2, 4-125  
CLASS-Call Setup Vol. 3, 4-113  
Custom Local Area Signaling Service  
Vol. 1, 6-119
- Dual Remote Cluster Controller  
Vol. 3, 4-191
- Dual Remote Cluster Controller (DRCC)  
Vol. 1, 6-158
- Emergency Stand-Alone Operation  
Vol. 1, 5-127
- ESA call processing Vol. 1, 3-116,  
Vol. 1, 4-97, Vol. 2, 7-133
- Firmware Downloading Vol. 1, 6-271
- firmware downloading Vol. 3, 4-275
- ISDN on RSC-S Vol. 3, 4-215
- Meridian Digital Centrex Basic  
Vol. 2, 3-149, Vol. 3, 5-119
- New Peripheral Maintenance Package  
Vol. 1, 6-241
- OPM Maintenance Vol. 1, 5-153
- Outside Plant Module Vol. 1, 3-98
- Remote Line Concentrating Module  
Vol. 1, 3-13, Vol. 1, 4-13, Vol. 1, 5-11
- RLCM Intracalling Vol. 1, 3-108,  
Vol. 1, 4-133, Vol. 1, 5-163
- RSC Enhanced ESA (Lines and Trunks)  
Vol. 3, 4-316
- RSC Enhanced ESA Lines and Trunks  
Vol. 1, 6-169
- RSC ESA lines Vol. 1, 6-179
- RSC Trunking Vol. 1, 6-253
- RSC-ESA Line and Trunks Vol. 1, 6-201
- RSC-ESA lines Vol. 3, 4-157
- RSC-ESA lines and trunks Vol. 3, 4-172
- RSC-S basic call processing Vol. 3, 4-39
- RSC-S dynamic trunks Vol. 3, 4-140
- RSC-S Enhanced ESA for ISDN (Lines and  
Trunks) Vol. 3, 4-345
- RSC-S Enhanced ESA for ISDN (Lines  
Only) Vol. 3, 4-331
- SCM SLC-96 Basic Vol. 2, 3-22
- Special Services for Subscriber Carrier  
Module Vol. 2, 3-151
- Special Services for Subscriber Carrier  
Module Remote Vol. 3, 5-99
- Star Remote Hub basic call processing  
Vol. 2, 7-26
- Subscriber Module SLC-96/Remote  
Vol. 3, 5-22

- Subscriber Module SLC-96/Remote  
Vol. 3, 4-290
- XPM-PLUS Basic Vol. 1, 6-279
- Operation
  - Expanded Subscriber Carrier Module-100  
Access (ESMA) Vol. 3, 3-71
  - Subscriber Carrier Module-100 Access  
Vol. 2, 5-61
- operation
  - BAS RSC Vol. 1, 6-16
  - CLASS features Vol. 2, 3-122, Vol. 2, 4-121
  - CLASS-Call Setup Vol. 3, 4-109
  - Custom Local Area Signaling Service  
Vol. 1, 6-115
  - Dual Remote Cluster Controller  
Vol. 3, 4-187
  - Dual Remote Cluster Controller (DRCC)  
Vol. 1, 6-142
  - Emergency Stand-Alone Operation  
Vol. 1, 5-125
  - ESA call processing Vol. 1, 3-113,  
Vol. 1, 4-94, Vol. 2, 7-129
  - Firmware Downloading Vol. 1, 6-270
  - firmware downloading Vol. 3, 4-271
  - ISDN on RSC-S Vol. 3, 4-204
  - Meridian Digital Centrex Basic  
Vol. 2, 3-148, Vol. 3, 5-117
  - OPM Maintenance Vol. 1, 5-150
  - Outside Plant Module Vol. 1, 3-96
  - Remote Line Concentrating Module  
Vol. 1, 3-11, Vol. 1, 4-11, Vol. 1, 5-10
  - RLCM Intracalling Vol. 1, 3-106,  
Vol. 1, 4-131, Vol. 1, 5-161
  - RSC Enhanced ESA (Lines and Trunks)  
Vol. 3, 4-312
  - RSC Enhanced ESA Lines and Trunks  
Vol. 1, 6-166
  - RSC ESA lines Vol. 1, 6-176
  - RSC Trunking Vol. 1, 6-249
  - RSC-ESA lines Vol. 3, 4-154
  - RSC-ESA lines and trunks Vol. 3, 4-169
  - RSC-S basic call processing Vol. 3, 4-25
  - RSC-S dynamic trunks Vol. 3, 4-138
  - RSC-S Enhanced ESA for ISDN (Lines and  
Trunks) Vol. 3, 4-340
  - RSC-S Enhanced ESA for ISDN (Lines  
Only) Vol. 3, 4-329
  - SCM SLC-96 Basic Vol. 2, 3-20
  - Special Services for Subscriber Carrier  
Module Vol. 2, 3-150
  - Special Services for Subscriber Carrier  
Module Remote Vol. 3, 5-98
  - Star Remote Hub basic call processing  
Vol. 2, 7-21
  - Subscriber Module SLC-96/Remote  
Vol. 3, 5-21
  - Subscriber Module SLC-96/Remote  
Vol. 3, 4-288
  - XPM-PLUS Basic Vol. 1, 6-278
- Operations gateway (OGW)
  - functional elements Vol. 2, 5-24, Vol. 2, 6-23,  
Vol. 3, 3-36
- OPM Maintenance feature package
  - office parameters
    - OPM\_CHARGE\_DURATION Vol. 1, 5-154
    - OPM\_CHARGE\_START\_TIME  
Vol. 1, 5-154
    - OPM\_DISCHARGE\_TIME Vol. 1, 5-155
    - OPM\_MIN\_CHG\_VOLT Vol. 1, 5-155
    - OPM\_VOLT\_TST\_CHG Vol. 1, 5-156
    - OPM\_VOLT\_TST\_DIS Vol. 1, 5-156
    - OPM\_VOLT\_TST\_LTU\_ADJUSTMENT  
Vol. 1, 5-157
    - OPM\_VOLT\_TST\_OCC Vol. 1, 5-155
- OPMINV, table
  - datafilling Vol. 1, 3-102, Vol. 1, 5-158
- Origination and channel allocation  
Vol. 2, 5-31, Vol. 2, 5-32, Vol. 2, 5-34, Vol. 2, 5-35,  
Vol. 2, 6-30, Vol. 2, 6-31, Vol. 2, 6-33, Vol. 3, 3-43,  
Vol. 3, 3-44, Vol. 3, 3-46, Vol. 3, 3-47
- Outside Plant Access Cabinet (OPAC)
  - datafilling
    - preparation Vol. 1, 5-8
    - procedures Vol. 1, 5-9
    - tasks Vol. 1, 5-9
  - message channels Vol. 1, 5-3
  - overview Vol. 1, 5-1
  - protocol
    - DMS-X Vol. 1, 5-4



signaling Vol. 1, 5-2  
 call origination Vol. 1, 5-6  
 dial pulse Vol. 1, 5-7  
 digit collection Vol. 1, 5-6  
 DTMF Vol. 1, 5-7  
 end-to-end Vol. 1, 5-7  
 ESA Vol. 1, 5-8  
 links Vol. 1, 5-3  
 protocol Vol. 1, 5-4  
 ringing Vol. 1, 5-7  
 tone origination Vol. 1, 5-6

## **P**

### **Path Protection**

CSC Vol. 2, 5-6, Vol. 2, 5-7, Vol. 2, 6-9,  
 Vol. 3, 3-17, Vol. 3, 3-18  
 EOC Vol. 2, 5-7, Vol. 2, 6-9, Vol. 3, 3-18

### **Path protection**

TMC Vol. 2, 6-8, Vol. 3, 3-16

### **Path protection switching** Vol. 2, 6-13

### **PBX**

central office access Vol. 2, 5-47, Vol. 2, 6-41,  
 Vol. 3, 3-58

### **PMLOADS, table**

datafilling Vol. 1, 6-272, Vol. 2, 3-35,  
 Vol. 2, 5-85, Vol. 2, 6-74, Vol. 3, 2-33,  
 Vol. 3, 3-95, Vol. 3, 4-46, Vol. 3, 4-219,  
 Vol. 3, 4-276, Vol. 3, 4-292, Vol. 3, 5-34

### **PMNODES, table**

datafilling Vol. 1, 3-27, Vol. 1, 4-29,  
 Vol. 1, 5-27, Vol. 1, 6-48, Vol. 2, 3-41,  
 Vol. 2, 4-40, Vol. 2, 5-71, Vol. 2, 6-61,  
 Vol. 2, 7-36, Vol. 3, 2-17, Vol. 3, 3-97, Vol. 3, 4-52

### **POTS** Vol. 2, 5-40, Vol. 2, 6-38, Vol. 3, 3-51

flat rate Vol. 2, 5-40, Vol. 2, 6-38, Vol. 3, 3-51  
 party multirate Vol. 2, 5-40, Vol. 2, 6-38,  
 Vol. 3, 3-51

### **Prerequisites**

Subscriber Carrier Module-100 Access  
 Vol. 2, 5-60

### **prerequisites**

BAS RSC Vol. 1, 6-14  
 CLASS features Vol. 2, 3-121, Vol. 2, 4-120  
 CLASS-Call Setup Vol. 3, 4-108  
 Custom Local Area Signaling Service  
 Vol. 1, 6-113

### **Dual Remote Cluster Controller**

Vol. 3, 4-185

### **Dual Remote Cluster Controller (DRCC)**

Vol. 1, 6-140

### **Emergency Stand-Alone Operation**

Vol. 1, 5-124

ESA call processing Vol. 1, 3-112, Vol. 1, 4-94

Firmware Downloading Vol. 1, 6-267

firmware downloading Vol. 3, 4-271

ISDN on RSC-S Vol. 3, 4-201

### **Meridian Digital Centrex Basic**

Vol. 2, 3-148, Vol. 3, 5-117

### **New Peripheral Maintenance Package**

Vol. 1, 6-236

Outside Plant Module Vol. 1, 3-95

### **Remote Line Concentrating Module**

Vol. 1, 3-11, Vol. 1, 4-11, Vol. 1, 5-10

RLCM Intracalling Vol. 1, 3-106,

Vol. 1, 4-131, Vol. 1, 5-161

### **RSC Enhanced ESA (Lines and Trunks)**

Vol. 3, 4-311

### **RSC Enhanced ESA Lines and Trunks**

Vol. 1, 6-164

RSC ESA lines Vol. 1, 6-175

RSC Trunking Vol. 1, 6-246

RSC-ESA Line and Trunks Vol. 1, 6-193

RSC-ESA lines Vol. 3, 4-149

RSC-ESA lines and trunks Vol. 3, 4-166

RSC-S basic call processing Vol. 3, 4-22

RSC-S Enhanced ESA for ISDN (Lines and  
 Trunks) Vol. 3, 4-339

RSC-S Enhanced ESA for ISDN (Lines  
 Only) Vol. 3, 4-328

SCM SLC-96 Basic Vol. 2, 3-19

Special Services for Subscriber Carrier  
 Module Vol. 2, 3-150

Special Services for Subscriber Carrier  
 Module Remote Vol. 3, 5-98

Star Remote Hub basic call processing  
 Vol. 2, 7-20

Subscriber Module SLC-96/Remote  
 Vol. 3, 5-21

Subscriber Module SLC-96/Remote  
 Vol. 3, 4-288

XPM-PLUS Basic Vol. 1, 6-278

Private Branch Exchange Vol. 2, 5-47,  
 Vol. 2, 6-41, Vol. 3, 3-58  
 Product Computing Module Loads (PCLs)  
 Vol. 1, 5-8  
 Provisioning  
     MADN for SMA-S/DMS AccessNode con-  
     figuration Vol. 2, 5-46  
 PSNAILUP  
     datafilling Vol. 3, 5-102  
 PSNAILUP, table  
     datafilling Vol. 2, 3-153

## Q

Q.931  
     message descriptions Vol. 2, 5-22,  
     Vol. 2, 6-22, Vol. 3, 3-34  
         call proceeding Vol. 2, 5-22, Vol. 2, 6-22,  
         Vol. 3, 3-34  
         connect Vol. 2, 5-23, Vol. 2, 6-22, Vol. 3, 3-34  
         disconnect Vol. 2, 5-23, Vol. 2, 6-22,  
         Vol. 3, 3-34  
         information Vol. 2, 5-23, Vol. 2, 6-22,  
         Vol. 3, 3-34  
         release Vol. 2, 5-23, Vol. 2, 6-22, Vol. 3, 3-35  
         release complete Vol. 2, 5-23, Vol. 2, 6-22,  
         Vol. 3, 3-35  
         setup Vol. 2, 6-23, Vol. 3, 3-35  
         status Vol. 2, 5-24, Vol. 2, 6-23, Vol. 3, 3-36  
         status inquiry Vol. 2, 5-24, Vol. 2, 6-23,  
         Vol. 3, 3-36

## R

RCC2  
     abilities Vol. 3, 4-311  
 RCCINV table  
     datafilling Vol. 3, 4-173  
 RCCINV, table  
     DATAFILLING Vol. 3, 4-346  
     datafilling Vol. 1, 6-63, Vol. 1, 6-120,  
     Vol. 1, 6-158, Vol. 1, 6-169, Vol. 1, 6-184,  
     Vol. 1, 6-205, Vol. 1, 6-243, Vol. 1, 6-256,  
     Vol. 1, 6-275, Vol. 1, 6-279, Vol. 2, 7-46,  
     Vol. 3, 4-67, Vol. 3, 4-114, Vol. 3, 4-140,  
     Vol. 3, 4-158, Vol. 3, 4-191, Vol. 3, 4-233,  
     Vol. 3, 4-284, Vol. 3, 4-299, Vol. 3, 4-317,  
     Vol. 3, 4-332

RCCPSINV, table  
     datafilling Vol. 1, 6-71, Vol. 3, 4-143,  
     Vol. 3, 4-199, Vol. 3, 4-241, Vol. 3, 4-302  
 RCCPSINV, table  
     datafilling Vol. 2, 7-53, Vol. 3, 4-75  
 RCSINV, table  
     datafilling Vol. 2, 3-54, Vol. 3, 5-46  
 RDT Vol. 2, 5-12, Vol. 2, 5-32, Vol. 2, 5-33,  
 Vol. 2, 5-35, Vol. 2, 5-36, Vol. 2, 5-37, Vol. 2, 5-38,  
 Vol. 2, 6-14, Vol. 2, 6-30, Vol. 2, 6-31, Vol. 2, 6-32,  
 Vol. 2, 6-33, Vol. 2, 6-35, Vol. 2, 6-36, Vol. 3, 3-23,  
 Vol. 3, 3-43, Vol. 3, 3-44, Vol. 3, 3-45, Vol. 3, 3-47,  
 Vol. 3, 3-48, Vol. 3, 3-49  
     signaling Vol. 2, 5-4, Vol. 2, 6-4, Vol. 3, 3-6  
 RDTLT, table  
     datafilling Vol. 2, 5-154  
 RECEIVER, table  
     datafilling Vol. 2, 7-95  
 Remote Switching Center (RSC)  
     circuit cards Vol. 1, 6-2  
     configurations Vol. 1, 6-4  
         DS0-1 electrical interface Vol. 1, 6-9  
     datafill preparation Vol. 1, 6-9  
     datafill requirements Vol. 1, 6-10  
     dual configuration with trunking  
         illustration Vol. 1, 6-8  
     dual configuration without trunking  
         illustration Vol. 1, 6-6  
     frames  
         illustrations Vol. 1, 6-3  
     services Vol. 1, 6-4  
     single configuration with trunking  
         illustration Vol. 1, 6-7  
     single configuration without trunking  
         illustration Vol. 1, 6-5  
     software delivery Vol. 1, 6-9  
     software functions Vol. 1, 6-1  
     translations Vol. 1, 6-1  
 Remote Switching Center-SONET (RSC-S)  
     and RSC Vol. 3, 4-2  
     configurations Vol. 3, 4-8  
     datafill preparation Vol. 3, 4-16  
         configurations Vol. 3, 4-17  
         end-user data  
             collecting Vol. 3, 4-17  
             requirements Vol. 3, 4-18  
     description Vol. 3, 4-1  
     development Vol. 3, 4-2

- 
- DS-1 electrical interface Vol. 3, 4-13
  - dual RSC-S with ISDN
    - illustration Vol. 3, 4-12
  - dual RSC-S without ISDN
    - illustration Vol. 3, 4-10
  - packaging Vol. 3, 4-3
  - services Vol. 3, 4-7
  - signaling Vol. 3, 4-14
    - additions Vol. 3, 4-14
    - DDL to SLC-96 Vol. 3, 4-14
    - extended time format Vol. 3, 4-15
    - SONET format Vol. 3, 4-16
  - single RSC-S with ISDN
    - illustration Vol. 3, 4-11
  - single RSC-S without ISDN
    - illustration Vol. 3, 4-9
  - software Vol. 3, 4-2
  - software delivery Vol. 3, 4-16
  - system architecture Vol. 3, 4-3
  - translations Vol. 3, 4-1
  - RESFEAT, table
    - datafilling Vol. 1, 6-135, Vol. 2, 3-142, Vol. 2, 4-138, Vol. 3, 4-128
  - RESOFC, table
    - datafilling Vol. 1, 6-128, Vol. 2, 3-136, Vol. 2, 4-133, Vol. 3, 4-123
  - Restrictions
    - Subscriber Carrier Module-100 Access Vol. 2, 5-62
  - restrictions
    - BAS RSC Vol. 1, 6-30
    - CLASS features Vol. 2, 3-123, Vol. 2, 4-122
    - CLASS-Call Setup Vol. 3, 4-110
    - Custom Local Area Signaling Service Vol. 1, 6-116
    - Dual Remote Cluster Controller Vol. 3, 4-188
    - Dual Remote Cluster Controller (DRCC) Vol. 1, 6-142
    - Emergency Stand-Alone Operation Vol. 1, 5-126
    - ESA call processing Vol. 1, 3-115, Vol. 1, 4-96, Vol. 2, 7-131
    - Firmware Downloading Vol. 1, 6-271
    - firmware downloading Vol. 3, 4-275
    - ISDN on RSC-S Vol. 3, 4-215
    - Meridian Digital Centrex Basic Vol. 2, 3-148, Vol. 3, 5-118
    - OPM Maintenance Vol. 1, 5-152
    - Outside Plant Module Vol. 1, 3-97
    - Remote Line Concentrating Module Vol. 1, 3-12, Vol. 1, 4-12, Vol. 1, 5-10
    - RLCM Intracalling Vol. 1, 3-107, Vol. 1, 4-132, Vol. 1, 5-162
    - RSC Enhanced ESA (Lines and Trunks) Vol. 3, 4-315
    - RSC Enhanced ESA Lines and Trunks Vol. 1, 6-167
    - RSC ESA lines Vol. 1, 6-178
    - RSC Trunking Vol. 1, 6-252
    - RSC-ESA Line and Trunks Vol. 1, 6-200
    - RSC-ESA lines Vol. 3, 4-156
    - RSC-ESA lines and trunks Vol. 3, 4-171
    - RSC-S basic call processing Vol. 3, 4-39
    - RSC-S dynamic trunks Vol. 3, 4-139
    - RSC-S Enhanced ESA for ISDN (Lines and Trunks) Vol. 3, 4-344
    - RSC-S Enhanced ESA for ISDN (Lines Only) Vol. 3, 4-330
    - SCM SLC-96 Basic Vol. 2, 3-21
    - Special Services for Subscriber Carrier Module Vol. 2, 3-151
    - Special Services for Subscriber Carrier Module Remote Vol. 3, 5-99
    - Star Remote Hub basic call processing Vol. 2, 7-22
    - Subscriber Module SLC-96/Remote Vol. 3, 5-21
    - Subscriber Module SLC-96/Remote Vol. 3, 4-290
    - XPM-PLUS Basic Vol. 1, 6-279
  - REXSCHED, table
    - datafilling Vol. 1, 3-52, Vol. 1, 4-52, Vol. 1, 5-43, Vol. 1, 6-86, Vol. 2, 7-85, Vol. 3, 4-84
  - RFT Vol. 2, 5-3, Vol. 3, 3-5, Vol. 3, 3-70
  - Ringling
    - description of Vol. 2, 5-35, Vol. 2, 5-36, Vol. 2, 6-34, Vol. 3, 3-47, Vol. 3, 3-48
    - distinctive Vol. 2, 5-49, Vol. 2, 6-42, Vol. 3, 3-59
    - distinctive ringling Vol. 2, 5-35, Vol. 2, 6-34, Vol. 3, 3-47
-

- single party Vol. 2, 5-49, Vol. 2, 6-42,  
Vol. 3, 3-59
- single#1e>party Vol. 2, 5-35, Vol. 2, 6-34,  
Vol. 3, 3-47
- SMA2 Vol. 2, 5-49, Vol. 2, 6-42, Vol. 3, 3-59
- RLCM/OPM**
- datafill preparation Vol. 1, 3-8, Vol. 1, 4-8
- PCLs Vol. 1, 3-8, Vol. 1, 4-8
- procedures Vol. 1, 3-9, Vol. 1, 4-9
- tasks Vol. 1, 3-9, Vol. 1, 4-9
- overview Vol. 1, 3-1, Vol. 1, 4-1
- signaling Vol. 1, 3-2, Vol. 1, 4-2
- functions Vol. 1, 3-5, Vol. 1, 3-6, Vol. 1, 3-7,  
Vol. 1, 3-8, Vol. 1, 3-10, Vol. 1, 4-5, Vol. 1, 4-6,  
Vol. 1, 4-7, Vol. 1, 4-8
- links Vol. 1, 3-2, Vol. 1, 4-2
- protocol Vol. 1, 3-3, Vol. 1, 4-3
- system integration
- (illustration) Vol. 1, 3-2, Vol. 1, 4-2
- translations Vol. 1, 3-1, Vol. 1, 4-1
- RLCM/OPM ordering code**
- table Vol. 1, 3-9, Vol. 1, 4-9
- RMMINV, table**
- datafilling Vol. 1, 3-50, Vol. 1, 4-49,  
Vol. 1, 5-42, Vol. 1, 6-84, Vol. 3, 4-82,  
Vol. 3, 4-249
- RMPCKT, table**
- datafilling Vol. 2, 7-75
- Robbed bit signaling Vol. 2, 6-7
- RTDINV, table**
- datafilling Vol. 2, 5-107, Vol. 3, 2-60,  
Vol. 3, 3-123, Vol. 3, 3-225
- S**
- S/DMS AccessNode Vol. 3, 3-5, Vol. 3, 3-67,  
Vol. 3, 3-70
- SCGRP, table**
- datafilling Vol. 1, 3-67, Vol. 1, 4-67,  
Vol. 1, 5-62, Vol. 1, 5-94, Vol. 2, 3-82,  
Vol. 2, 5-164, Vol. 3, 5-69
- SDGRP, table**
- datafilling Vol. 1, 3-68, Vol. 1, 4-68,  
Vol. 1, 5-64, Vol. 1, 5-95, Vol. 2, 3-83,  
Vol. 2, 5-165, Vol. 3, 5-70
- Series 800E Cabinet Vol. 1, 5-150
- Services Vol. 2, 5-40, Vol. 2, 6-38, Vol. 3, 3-51
- 800 Vol. 2, 5-48, Vol. 2, 6-41, Vol. 3, 3-58
- SSP Vol. 2, 5-48, Vol. 2, 6-41, Vol. 3, 3-58
- CLASS**
- card Vol. 2, 5-45, Vol. 2, 6-40, Vol. 3, 3-56
- coin Vol. 2, 5-40, Vol. 2, 6-38, Vol. 3, 3-52
- EBS Vol. 2, 5-43
- ISDN**
- voice and data Vol. 2, 5-48, Vol. 2, 6-41,  
Vol. 3, 3-59
- MADN Vol. 2, 5-46, Vol. 3, 3-56
- MDC Vol. 2, 5-45, Vol. 2, 6-40, Vol. 3, 3-56
- PBX**
- central office access Vol. 2, 5-47,  
Vol. 2, 6-41, Vol. 3, 3-58
- toll diversion Vol. 2, 5-48, Vol. 2, 6-41,  
Vol. 3, 3-58
- POTS Vol. 2, 5-40, Vol. 2, 6-38, Vol. 3, 3-51
- residential Vol. 2, 5-47, Vol. 2, 6-41,  
Vol. 3, 3-58
- POTS Vol. 2, 5-47, Vol. 2, 6-41, Vol. 3, 3-58
- secretarial line Vol. 2, 5-47, Vol. 2, 6-41,  
Vol. 3, 3-58
- teen Vol. 2, 5-47, Vol. 2, 6-41, Vol. 3, 3-58
- UTR Vol. 2, 5-45, Vol. 2, 6-40, Vol. 3, 3-55
- WATS**
- INWATS Vol. 2, 5-48, Vol. 2, 6-41,  
Vol. 3, 3-58
- OUTWATS Vol. 2, 5-48, Vol. 2, 6-41,  
Vol. 3, 3-58
- two#1e>way WATS Vol. 2, 5-48,  
Vol. 2, 6-41, Vol. 3, 3-58
- SFWALARM, table**
- datafilling Vol. 2, 5-141, Vol. 2, 6-126,  
Vol. 3, 2-83, Vol. 3, 3-160
- Signaling**
- A- and B-bit Vol. 2, 5-3, Vol. 2, 6-3, Vol. 2, 7-5,  
Vol. 3, 3-5
- CSC Vol. 2, 5-6, Vol. 3, 3-13
- FXS Vol. 3, 3-10
- in-band Vol. 2, 6-7, Vol. 3, 3-14
- ISDN BRI Vol. 2, 5-3, Vol. 2, 6-3, Vol. 2, 7-5,  
Vol. 3, 3-5
- out-of-band Vol. 2, 6-6, Vol. 3, 3-14
- RBS Vol. 2, 6-7
- TMC Vol. 2, 6-6, Vol. 3, 3-13
- TR-303 hybrid Vol. 2, 6-6, Vol. 3, 3-13

- SITE**, table  
 datafilling Vol. 3, 4-44, Vol. 3, 4-219
- SITE**, table  
 datafilling Vol. 1, 3-25, Vol. 1, 4-25,  
 Vol. 1, 5-24, Vol. 1, 6-40, Vol. 2, 3-27,  
 Vol. 2, 5-69, Vol. 2, 7-34, Vol. 3, 4-291,  
 Vol. 3, 5-27
- SMA**  
 capabilities Vol. 2, 6-38
- SMA2**  
 services Vol. 3, 3-51
- SOFTKEY**, table  
 datafilling Vol. 1, 6-123, Vol. 2, 3-128,  
 Vol. 2, 4-127, Vol. 2, 5-181, Vol. 2, 6-162,  
 Vol. 3, 2-118, Vol. 3, 3-201, Vol. 3, 4-118
- SPECCONN**, table  
 datafilling Vol. 2, 5-103, Vol. 3, 4-256
- Speed Calling** Vol. 2, 5-43
- STAR**  
 signaling Vol. 2, 7-10  
 links Vol. 2, 7-11  
 MBS Vol. 2, 7-14  
 signaling functions  
 call origination Vol. 2, 7-11  
 digit collection Vol. 2, 7-12  
 end-to-end signaling Vol. 2, 7-13  
 ESA signaling Vol. 2, 7-14  
 ringing Vol. 2, 7-13  
 tone generation Vol. 2, 7-12  
 signaling protocols  
 HDLC protocol Vol. 2, 7-10
- Star Remote Hub** Vol. 2, 7-1  
 datafill preparation  
 procedures Vol. 2, 7-18, Vol. 2, 7-19  
 tasks Vol. 2, 7-18  
 overview Vol. 2, 7-1
- Star Remote Module**  
 overview Vol. 2, 7-2
- Star Remote System**  
 configuration Vol. 2, 7-4  
 introduction Vol. 2, 7-1
- Station Message Detail Recording**  
 RSC-S dynamic trunks Vol. 3, 4-140
- Subscriber Carrier Module -100S (SMS)**  
 datafill preparation Vol. 2, 3-16  
 controlling RCS modes Vol. 2, 3-17  
 protection lines Vol. 2, 3-17  
 special services nailed-up cross connections  
 Vol. 2, 3-17  
 static datalog tracking Vol. 2, 3-18  
 tasks Vol. 2, 3-17
- signaling** Vol. 2, 3-1
- signaling protocols** Vol. 2, 3-3  
 A- and B-bit messages Vol. 2, 3-3  
 DDL messages Vol. 2, 3-3  
 DMS-X handshaking protocol  
 illustration Vol. 2, 3-4  
 DMS-X message format  
 illustration Vol. 2, 3-5  
 DMS-X protocol Vol. 2, 3-4  
 nailed-up cross-connections Vol. 2, 3-6
- SMS-RCS signaling functions** Vol. 2, 3-6  
 A- and B-bit messaging Vol. 2, 3-6  
 call processing Vol. 2, 3-8  
 CLASS features Vol. 2, 3-9  
 coin features Vol. 2, 3-6  
 custom calling services Vol. 2, 3-9  
 dataport cross-connection Vol. 2, 3-13  
 DDL messaging Vol. 2, 3-11  
 dialing Vol. 2, 3-10  
 frequency selective ringing Vol. 2, 3-10  
 MDC on SMS Vol. 2, 3-10  
 nailed-up cross-connections Vol. 2, 3-12,  
 Vol. 2, 3-14  
 PBX line Vol. 2, 3-9  
 POTS Vol. 2, 3-6  
 ringing Vol. 2, 3-9  
 tones Vol. 2, 3-10  
 universal tone receiver (UTR) Vol. 2, 3-7
- SMS-RCS signaling links** Vol. 2, 3-1  
 software delivery Vol. 2, 3-16  
 translations Vol. 2, 3-1
- Subscriber Carrier Module-100 Access**  
 automatic maintenance  
 path protection switching Vol. 2, 5-13,  
 Vol. 2, 6-15
- Communication protocols** Vol. 2, 5-14  
 description  
 coin call messages Vol. 2, 5-42, Vol. 2, 6-40  
 Meridian business set (MBS) messaging  
 Vol. 2, 5-44
- Path protection switching** Vol. 2, 5-12  
 protocol  
 DS30 Vol. 2, 5-14, Vol. 2, 6-16  
 EOC Vol. 2, 5-14, Vol. 2, 6-16  
 Q.921 Vol. 2, 5-14, Vol. 2, 6-16  
 Q.931 Vol. 2, 5-14, Vol. 2, 6-16

- protocols
  - DS30 Vol. 2, 5-28, Vol. 2, 6-26
- services Vol. 2, 5-40
- signaling
  - DS30 protocol Vol. 2, 5-29, Vol. 2, 6-28
- SMA system
  - description Vol. 2, 5-1, Vol. 2, 6-1
- Subscriber Carrier Module-100 Access (SMA)
  - datafill preparation Vol. 2, 5-56
  - data logs
    - tracking Vol. 2, 5-56
  - data, static
    - updating Vol. 2, 5-57
  - software delivery Vol. 2, 5-56
  - tasks associated Vol. 2, 5-56
- description Vol. 2, 5-1
- translating Vol. 2, 5-1

- Subscriber loop
- protocol Vol. 2, 7-17
- Superframe format (SF) signaling Vol. 2, 7-6

## T

- table editor
  - commands Vol. 1, 2-4, Vol. 2, 2-4, Vol. 3, 2-4
  - using Vol. 1, 2-2, Vol. 2, 2-2, Vol. 3, 2-2
- Table flow
  - Subscriber Carrier Module-100 Access Vol. 2, 5-62
- table flow
  - BAS RSC Vol. 1, 6-26
  - CLASS features Vol. 2, 3-123, Vol. 2, 4-122
  - CLASS-Call Setup Vol. 3, 4-110
  - Custom Local Area Signaling Service Vol. 1, 6-115
  - Dual Remote Cluster Controller Vol. 3, 4-187
  - Dual Remote Cluster Controller (DRCC) Vol. 1, 6-142
  - Emergency Stand-Alone Operation Vol. 1, 5-126
  - ESA call processing Vol. 1, 3-114, Vol. 1, 4-96, Vol. 2, 7-130
  - Firmware Downloading Vol. 1, 6-270
  - firmware downloading Vol. 3, 4-274
  - ISDN on RSC-S Vol. 3, 4-206
  - Meridian Digital Centrex Basic Vol. 2, 3-148, Vol. 3, 5-117

- New Peripheral Maintenance Package Vol. 1, 6-240
- OPM Maintenance Vol. 1, 5-152
- Outside Plant Module Vol. 1, 3-97
- Remote Line Concentrating Module Vol. 1, 3-12, Vol. 1, 4-11, Vol. 1, 5-10
- RLCM Intracalling Vol. 1, 3-107, Vol. 1, 4-132, Vol. 1, 5-162
- RSC Enhanced ESA (Lines and Trunks) Vol. 3, 4-313
- RSC Enhanced ESA Lines and Trunks Vol. 1, 6-167
- RSC ESA lines Vol. 1, 6-178
- RSC Trunking Vol. 1, 6-250
- RSC-ESA Line and Trunks Vol. 1, 6-195
- RSC-ESA lines Vol. 3, 4-155
- RSC-ESA lines and trunks Vol. 3, 4-169
- RSC-S basic call processing Vol. 3, 4-34
- RSC-S dynamic trunks Vol. 3, 4-138
- RSC-S Enhanced ESA for ISDN (Lines and Trunks) Vol. 3, 4-341
- RSC-S Enhanced ESA for ISDN (Lines Only) Vol. 3, 4-329
- SCM SLC-96 Basic Vol. 2, 3-21
- Special Services for Subscriber Carrier Module Vol. 2, 3-150
- Special Services for Subscriber Carrier Module Remote Vol. 3, 5-99
- Star Remote Hub basic call processing Vol. 2, 7-21
- Subscriber Module SLC-96/Remote Vol. 3, 5-21
- Subscriber Module SLC-96/Remote Vol. 3, 4-289
- XPM-PLUS Basic Vol. 1, 6-279

- Tables
- RDTINV Vol. 2, 5-15, Vol. 2, 6-17, Vol. 3, 3-26
- tables
- changing Vol. 1, 2-4, Vol. 2, 2-4, Vol. 3, 2-4
- Technical Education Course 0434 "ESMA Maintenance"
- Common signaling channel (CSC) signaling Vol. 3, 3-17
- Communication protocols Vol. 3, 3-25
- Embedded operations channel (EOC) signaling Vol. 3, 3-18

- Extended superframe format (ESF) signaling Vol. 3, 3-8
- Functions of main components Vol. 3, 3-1
- FXS signaling Vol. 3, 3-10
- Path protection switching Vol. 3, 3-22
- SERVORD Vol. 3, 2-122, Vol. 3, 3-205
- SMA2 services Vol. 3, 3-51
- Superframe format (SF) signaling  
Vol. 3, 3-6
- Table CARRMTC Vol. 3, 2-28, Vol. 3, 3-89,  
Vol. 3, 3-218
- Table LTCINV Vol. 3, 2-22, Vol. 3, 3-83
- Table LTCPSINV Vol. 3, 2-39, Vol. 3, 3-100,  
Vol. 3, 3-223
- Table RDTINV Vol. 3, 2-60, Vol. 3, 3-123,  
Vol. 3, 3-225
- TR-303 hybrid signaling Vol. 3, 3-14
- TEXLOG, table  
datafilling Vol. 1, 6-126
- TEXPHRS, table  
datafilling Vol. 1, 6-124
- TEXTLOG, table  
datafilling Vol. 2, 3-131, Vol. 2, 4-129,  
Vol. 2, 5-180, Vol. 2, 6-160, Vol. 3, 2-116,  
Vol. 3, 3-199, Vol. 3, 4-119
- TEXTPHRS, table  
datafilling Vol. 2, 3-130, Vol. 2, 4-128,  
Vol. 2, 5-178, Vol. 2, 6-159, Vol. 3, 2-114,  
Vol. 3, 3-197, Vol. 3, 4-119
- Three#1e>way Calling Vol. 2, 5-43
- TMC Vol. 2, 6-8, Vol. 2, 6-30, Vol. 2, 6-33,  
Vol. 3, 3-16, Vol. 3, 3-43, Vol. 3, 3-46  
call reference Vol. 2, 5-17, Vol. 2, 6-19,  
Vol. 3, 3-29  
information element Vol. 2, 5-19, Vol. 2, 6-21,  
Vol. 3, 3-30  
LAPD Vol. 2, 6-16, Vol. 3, 3-25  
message structure Vol. 2, 5-16, Vol. 2, 6-19,  
Vol. 3, 3-28  
path protection Vol. 2, 6-8, Vol. 3, 3-16  
protocol discriminator Vol. 2, 5-17,  
Vol. 2, 6-19, Vol. 3, 3-28  
Q.921 Vol. 2, 6-16, Vol. 3, 3-25  
Q.931 Vol. 2, 6-16, Vol. 3, 3-25
- TMINV, table  
datafilling Vol. 2, 3-65, Vol. 2, 5-137,  
Vol. 3, 5-52
- TOFCNAME, table  
datafilling Vol. 1, 3-69, Vol. 1, 4-69,  
Vol. 1, 5-64, Vol. 1, 5-96, Vol. 2, 7-103
- Tone generation Vol. 2, 5-32, Vol. 2, 5-33,  
Vol. 2, 5-34, Vol. 2, 5-36, Vol. 2, 5-37, Vol. 2, 6-31,  
Vol. 2, 6-32, Vol. 2, 6-35, Vol. 3, 3-44, Vol. 3, 3-45,  
Vol. 3, 3-48, Vol. 3, 3-49
- Tones Vol. 2, 5-49, Vol. 2, 6-43, Vol. 3, 3-60  
busy Vol. 2, 5-49, Vol. 2, 6-43, Vol. 3, 3-60  
dial Vol. 2, 5-49, Vol. 2, 6-43, Vol. 3, 3-60  
off#1e>hook Vol. 2, 5-49, Vol. 2, 6-43,  
Vol. 3, 3-60  
reorder Vol. 2, 5-49, Vol. 2, 6-43, Vol. 3, 3-60  
ringback Vol. 2, 5-49, Vol. 2, 6-43, Vol. 3, 3-60
- TR-303  
hybrid signaling Vol. 2, 6-6, Vol. 3, 3-14
- TR-303 I/F for MVI RDT  
datafilling Vol. 3, 2-7
- TR-303 I/F for S/DMS AccessNode  
datafilling Vol. 3, 3-70
- Translating  
RSC-ESA lines and trunks Vol. 3, 4-166  
Subscriber Carrier Module-100 Access  
Vol. 2, 5-60
- translating  
BAS RSC Vol. 1, 6-14  
CLASS features Vol. 2, 3-121, Vol. 2, 4-120  
CLASS-Call Setup Vol. 3, 4-108  
Custom Local Area Signaling Service  
Vol. 1, 6-113  
Dual Remote Cluster Controller  
Vol. 3, 4-185  
Dual Remote Cluster Controller (DRCC)  
Vol. 1, 6-140  
ESA call processing Vol. 1, 3-112, Vol. 1, 4-94  
Firmware Downloading Vol. 1, 6-267  
firmware downloading Vol. 3, 4-271  
ISDN on RSC-S Vol. 3, 4-201  
Meridian Digital Centrex Basic  
Vol. 2, 3-148, Vol. 3, 5-117  
New Peripheral Maintenance Package  
Vol. 1, 6-236  
Outside Plant Module Vol. 1, 3-95  
Remote Line Concentrating Module  
Vol. 1, 3-11, Vol. 1, 4-11  
RLCM Intracalling Vol. 1, 3-106,  
Vol. 1, 4-131

- RSC Enhanced ESA (Lines and Trunks) Vol. 3, 4-311
- RSC Enhanced ESA Lines and Trunks Vol. 1, 6-164
- RSC ESA lines Vol. 1, 6-175
- RSC Trunking Vol. 1, 6-246
- RSC-ESA Line and Trunks Vol. 1, 6-193
- RSC-ESA lines Vol. 3, 4-149
- RSC-S basic call processing Vol. 3, 4-22
- RSC-S dynamic trunks Vol. 3, 4-135
- RSC-S Enhanced ESA for ISDN (Lines and Trunks) Vol. 3, 4-339
- RSC-S Enhanced ESA for ISDN (Lines Only) Vol. 3, 4-328
- SCM SLC-96 Basic Vol. 2, 3-19
- Special Services for Subscriber Carrier Module Vol. 2, 3-150
- Special Services for Subscriber Carrier Module Remote Vol. 3, 5-98
- Star Remote Hub basic call processing Vol. 2, 7-20
- Subscriber Module SLC-96/Remote Vol. 3, 5-21
- Subscriber Module SLC-96/Remote Vol. 3, 4-288
- XPM-PLUS Basic Vol. 1, 6-278
- Translations
  - datafill sequence Vol. 1, 4-124, Vol. 1, 6-230, Vol. 2, 7-157, Vol. 3, 4-361
  - LCMDRINV Vol. 1, 4-125, Vol. 1, 6-230, Vol. 2, 7-157, Vol. 3, 4-361
  - LNINV Vol. 1, 4-127, Vol. 1, 6-232, Vol. 2, 7-159, Vol. 3, 4-363
  - table flow Vol. 1, 4-121, Vol. 1, 6-226, Vol. 2, 7-153, Vol. 3, 4-357
- TRKGRP table
  - datafilling Vol. 3, 4-181
- TRKGRP, table
  - datafilling Vol. 1, 3-56, Vol. 1, 4-56, Vol. 1, 5-46, Vol. 1, 6-88, Vol. 1, 6-207, Vol. 1, 6-258, Vol. 2, 3-67, Vol. 2, 5-138, Vol. 2, 7-88, Vol. 3, 4-87, Vol. 3, 4-324, Vol. 3, 5-54
- TRKMEM table
  - datafilling Vol. 3, 4-182
- TRKMEM, table
  - datafilling Vol. 1, 3-61, Vol. 1, 4-61, Vol. 1, 5-52, Vol. 1, 6-93, Vol. 1, 6-213, Vol. 1, 6-265, Vol. 2, 3-73, Vol. 2, 5-140, Vol. 2, 7-93, Vol. 3, 4-92, Vol. 3, 4-325, Vol. 3, 5-60, Vol. 3, 5-61
- TRKSGRP table
  - datafilling Vol. 3, 4-182
- TRKSGRP, table
  - datafilling Vol. 1, 3-58, Vol. 1, 4-58, Vol. 1, 5-48, Vol. 1, 6-90, Vol. 1, 6-210, Vol. 1, 6-262, Vol. 2, 3-69, Vol. 2, 5-140, Vol. 2, 7-90, Vol. 3, 4-89, Vol. 3, 4-325, Vol. 3, 5-56
- Trunks
  - test types Vol. 3, 4-89
- tuple properties Vol. 1, 2-1, Vol. 2, 2-1, Vol. 3, 2-1
  
- U**
  - Universal tone receiver Vol. 2, 5-45, Vol. 2, 6-40, Vol. 3, 3-55
  - UTR Vol. 2, 5-45, Vol. 2, 6-40, Vol. 3, 3-55
  
- W**
  - WATS Vol. 2, 5-48, Vol. 2, 6-41, Vol. 3, 3-58
  - Wide Area Telecommunications Services Vol. 2, 5-48, Vol. 2, 6-41, Vol. 3, 3-58
  
- X**
  - xDSL line card
    - protocol Vol. 2, 7-17
  - XESAINV, table
    - datafilling Vol. 1, 3-124, Vol. 1, 4-105, Vol. 1, 5-135





DMS-100 Family

## **Extended Peripheral Module**

Extended Peripheral Module Translations Reference Manual

Volume 3 of 3

Product Documentation-Dept. 3423  
Nortel Networks  
PO Box 13010  
RTP, NC 27709-3010  
Telephone: 1-877-662-5669  
Electronic mail: [cits@nortelnetworks.com](mailto:cits@nortelnetworks.com)

Copyright © 1994-2001 Nortel Networks,  
All Rights Reserved

**NORTEL NETWORKS CONFIDENTIAL:** The information contained herein is the property of Nortel Networks and is strictly confidential. Except as expressly authorized in writing by Nortel Networks, the holder shall keep all information contained herein confidential, shall disclose the information only to its employees with a need to know, and shall protect the information, in whole or in part, from disclosure and dissemination to third parties with the same degree of care it uses to protect its own confidential information, but with no less than reasonable care. Except as expressly authorized in writing by Nortel Networks, the holder is granted no rights to use the information contained herein.

Information is subject to change without notice. Nortel Networks reserves the right to make changes in design or components as progress in engineering and manufacturing may warrant. Changes or modification to the DMS-100 without the express consent of Nortel Networks may void its warranty and void the users authority to operate the equipment.

Nortel Networks, the Nortel Networks logo, the Globemark, How the World Shares Ideas, Unified Networks, DMS, DMS-100, Helmsman, MAP, Meridian, Nortel, Northern Telecom, NT, SuperNode, and TOPS are trademarks of Nortel Networks.

Publication number: 297-8321-815  
Product release: XPM14 and up  
Document release: Standard 14.01  
Date: March 2001  
Printed in the United States of America

